

Engineering Specification

Job Name _____
 Job Location _____
 Engineer _____
 Approval _____

Contractor _____
 Approval _____
 Contractor's P.O. No. _____
 Representative _____

FD-1160 Chemical Resistant Floor Drain

Specification

Watts FD-1160 chemical resistant PVC floor drain with anchor flange, reversible clamping collar with primary and secondary weepholes, 6 1/2" round heel proof adjustable PVC strainer secured with stainless steel screws, and socket outlet,



Call customer service if you need assistance with technical details.

Pipe Sizing		
Suffix	Description	
2	2"(51) Pipe Size	<input type="checkbox"/>
3	3"(76) Pipe Size	<input type="checkbox"/>
4	4"(102) Pipe Size	<input type="checkbox"/>

Options		
Suffix	Description	
-5	Sediment Bucket	<input type="checkbox"/>
-6	Vandal Proof	<input type="checkbox"/>
-7	Trap Primer Tapping	<input type="checkbox"/>
-8	Backwater Valve (2, 3, 4" Only)	<input type="checkbox"/>
-13	Galvanized Body	<input type="checkbox"/>
-15	Strainer Extension (DD-50)	<input type="checkbox"/>

Load Rating	Free Area Sq. In.
*LD	9

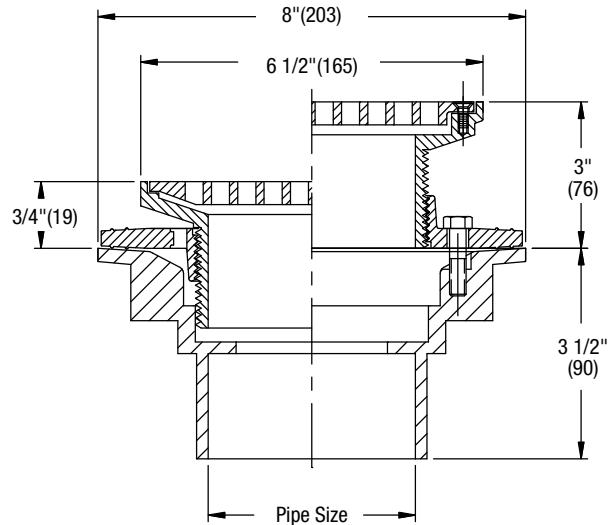

NOTICE

The information contained herein is not intended to replace the full product installation and safety information available or the experience of a trained product installer. You are required to thoroughly read all installation instructions and product safety information before beginning the installation of this product.

NOTICE

The load classifications are in accordance with the American National Standard ASME A112.21.1M ASME Ratings are as follows:
 LD - Safe Live Load under 2000 lbs.(900kg)
 The above categories are given as a guide only. Please Consult factory.

Watts product specifications in U.S. customary units and metric are approximate and are provided for reference only. For precise measurements, please contact Watts Technical Service. Watts reserves the right to change or modify product design, construction, specifications, or materials without prior notice and without incurring any obligation to make such changes and modifications on Watts products previously or subsequently sold.



USA: T: (800) 338-2581 • Watts.com
Canada: T: (888) 208-8927 • Watts.ca
Latin America: T: (52) 55-4122-0138 • Watts.com

