

Engineering Specification

Job Name _____

Contractor _____

Job Location _____

Approval _____

Engineer _____

Contractor's P.O. No. _____

Approval _____

Representative _____

QT-131-TAS QT QuickTurn™ Single Vertical Closet Carrier for 4" Rough-In w/Side Inlet(s)

Specification

Watts QT-131-TAS single vertical water closet carrier for 4" bowl outlet rough-in with epoxy coated cast iron fitting, 4" no hub waste and 2" no hub vent connections, 4" no hub side inlet(s), epoxy coated cast iron patented faceplate assembly, epoxy coated cast iron foot supports with incremental height markings, adjustable ABS nipple with integral test cap and neoprene bowl gasket, plated hardware and chrome cap nuts. Carrier complies with the requirements of ASME A112.6.1M up to a 500 lb. static load.

Call customer service if you need assistance with technical details.

Options	
Suffix	Description
QT-100-EXT	Aux. Support System w/Extended Nipple
-HS	Hub & Spigot Connections
-M1	ABS 24" Extended Nipple
-CA-N8-50-QT	8" Cast Iron Nipple
-CA-N24-50-QT	24" Cast Iron Nipple
-T	Threaded Nipple (Removes Tiling Plate)

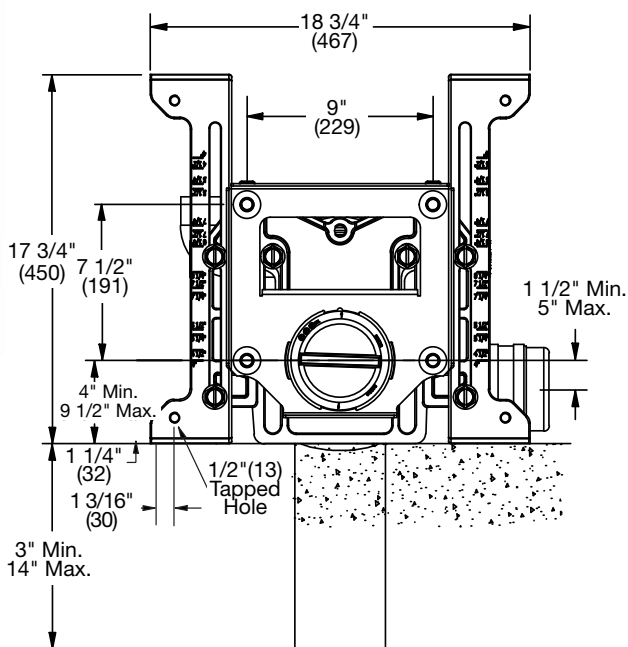
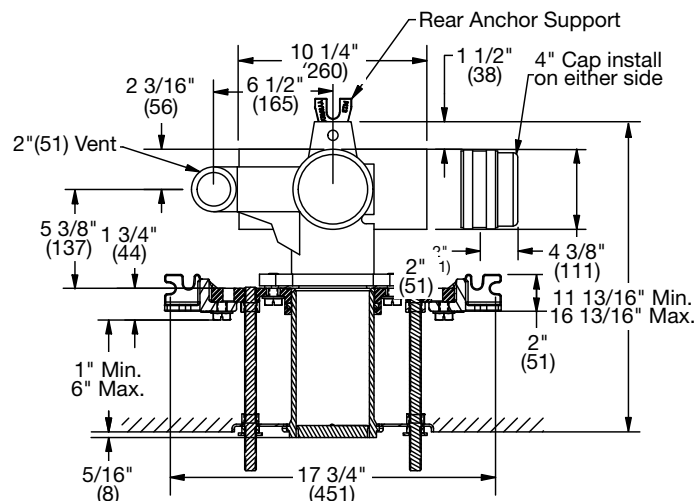

NOTICE

Anchor legs to concrete floor with minimum 1/2"(13) anchor bolts (by others).

Carrier feet with holes require two 1/2"(13) anchor bolts per foot. Rear slotted carrier feet require minimum one 1/2"(13) bolt per foot.

NOTICE

The information contained herein is not intended to replace the full product installation and safety information available or the experience of a trained product installer. You are required to thoroughly read all installation instructions and product safety information before beginning the installation of this product.

Watts product specifications in U.S. customary units and metric are approximate and are provided for reference only. For precise measurements, please contact Watts Technical Service. Watts reserves the right to change or modify product design, construction, specifications, or materials without prior notice and without incurring any obligation to make such changes and modifications on Watts products previously or subsequently sold.



USA: T: (800) 338-2581 • Watts.com

Canada: T: (888) 208-8927 • Watts.ca

Latin America: T: (52) 55-4122-0138 • Watts.com

ES-WD-QT-131-TAS 2513

© 2025 Watts

