

Engineering Specification

Job Name _____

Contractor _____

Job Location _____

Approval _____

Engineer _____

Contractor's P.O. No. _____

Approval _____

Representative _____

ISCA-141-4-D Industry Standard Back-to-Back Thin Wall Closet Carrier

Specification

Watts ISCA-141-4-D *Industry Standard* back-to-back vertical thin wall water closet carrier with epoxy coated cast iron fitting, 4" no hub waste and 2" or 4" vent connection, epoxy coated cast iron patented compression seal faceplate assembly, and epoxy coated cast iron foot supports with incremental height markings. Adjustable for standard and wheelchair height, adjustable ABS nipple with integral test cap and neoprene bowl gasket, plated hardware and chrome cap nuts. Carrier complies with requirements of ASME A112.6.1M up to 500 lb. static load.

Call customer service if you need assistance with technical details.

| OPTIONS | |
|---------|-----------------------------------|
| SUFFIX | DESCRIPTION |
| -BF | Assy. for 4" C/L Back Outlet Bowl |
| -CI | Cast Iron Nipple |
| -M1 | ABS Extended Nipple (Up to 24") |
| -M11 | Tiling Frame |
| -M20 | Flush Valve Support |
| -M23 | 2"(51) RH Auxiliary Inlet |
| -M24 | 2"(51) LH Auxiliary Inlet |
| -V2 | 2"(51) NH Vent Connection |
| -V4 | 4"(102) NH Vent Connection |

X = 5 3/4"(146) Maximum with Standard Nipple

NOTICE

Anchor legs to concrete floor with minimum 1/2"(13) anchor bolts (by others).

Dual slotted carrier feet require one 1/2"(13) anchor bolt per foot.

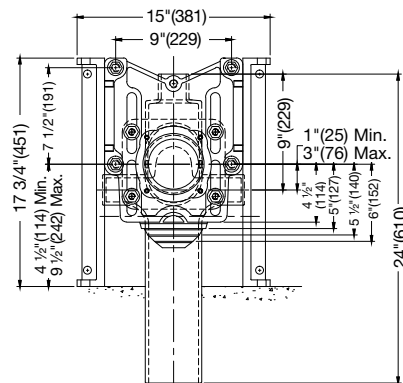
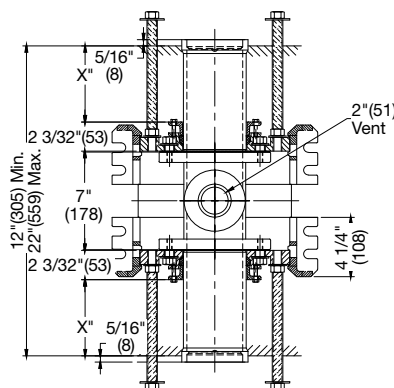

NOTICE

The information contained herein is not intended to replace the full product installation and safety information available or the experience of a trained product installer. You are required to thoroughly read all installation instructions and product safety information before beginning the installation of this product.

Watts product specifications in U.S. customary units and metric are approximate and are provided for reference only. For precise measurements, please contact Watts Technical Service. Watts reserves the right to change or modify product design, construction, specifications, or materials without prior notice and without incurring any obligation to make such changes and modifications on Watts products previously or subsequently sold.



USA: T: (800) 338-2581 • Watts.com

Canada: T: (888) 208-8927 • Watts.ca

Latin America: T: (52) 55-4122-0138 • Watts.com

ES-WD-ISCA-141-4-D 2609

© 2026 Watts