

## Engineering Specification

Job Name \_\_\_\_\_

Contractor \_\_\_\_\_

Job Location \_\_\_\_\_

Approval \_\_\_\_\_

Engineer \_\_\_\_\_

Contractor's P.O. No. \_\_\_\_\_

Approval \_\_\_\_\_

Representative \_\_\_\_\_

# Big Bubba® Filter Cartridges and Housings

## Residential and Commercial Cartridge Filtration

Connection Sizes: 2"

Flow Rates: Up to 150 gpm (567 lpm)

Watts® Big Bubba® filter cartridges and housings are an ideal choice for the reduction of sediment, chlorine, and other contaminants in water. They are suitable for residential and commercial applications with peak flow rates up to 150 gpm (567 lpm) for sediment reduction and peak flow rates up to 15 gpm (56 lpm) for chlorine reduction. If higher flow rates are required, multiple housings can be installed in parallel.

Watts Big Bubba advantages:

- No corrosion
- More economical than steel
- No backwashing/no wasted water
- No electricity
- Light weight
- Simple operation
- High flow and capacity

**Four types of filter cartridges are offered:**

Pleated - Sediment Reduction

Melt Blown - Sediment Reduction

Pleated Activated Carbon - Chlorine Taste & Odor Reduction

Activated Carbon Block - Lead/PFOS & PFOA/Cysts/Chlorine Taste & Odor Reduction

Applications for Big Bubba filter cartridges and housings include whole home, commercial and industrial, municipal, sea water\*, agriculture, aquariums, hotel, hospital, car wash, metal finishing and plating, food and beverage and much more.

\* For seawater or aggressive water applications, order separate filter housing lid Ordering Code # 68100617. This lid does not include the brass gauge port and is 100% non metallic.

### ⚠ WARNING

Do not use with water that is microbiologically unsafe or of unknown quality without adequate disinfection before or after the system.



Series Big Bubba

### Features

- Filter housing is constructed of glass reinforced polypropylene for excellent corrosion resistance and durability
- Union style PVC plumbing connections for fast installation and removal
- Dual outlets to accommodate a multitude of plumbing configurations
- Housing drain port
- Single cartridge to replace for quick and easy service
- 4 Filter cartridge types to choose from
- Double O-ring filter cartridge end seal prevents filter bypass
- High Flow Rates- Up to 150 gpm for sediment (Pleated) and 15 gpm for dechlorination (Pleated Activated Carbon)
- 140,000 Gallon chlorine capacity (Pleated Activated Carbon)
- Cartridge only needs ¼ turn to lock into position
- Includes inlet water pressure gauge
- Includes concrete anchors

### Standards

Filter Housing- Certified to NSF/ANSI 61

Watts product specifications in U.S. customary units and metric are approximate and are provided for reference only. For precise measurements, please contact Watts Technical Service. Watts reserves the right to change or modify product design, construction, specifications, or materials without prior notice and without incurring any obligation to make such changes and modifications on Watts products previously or subsequently sold.



## Specifications

A Watts Series Big Bubba® cartridge filter housing Model Number BBH-150 shall be installed on the building's main water line just after it enters the building. The installation point shall be after any backflow prevention or pressure regulating valves. Other installation options are to install the filter housing just before the plumbing equipment needing the protection of filtered water. In installations where the dedicated cold water make up to a water heater is the installation point, a backflow preventer and a thermal expansion tank must be installed as well. The filter housing shall be installed with a bypass valve to allow for shut down and servicing without interrupting the water supply to the building. The filter housing shall use a single replaceable filter cartridge. The filter housing shall be constructed of glass reinforced polypropylene, have 2" female socket weld PVC union plumbing connections, and a filter housing drain port. The filter housing shall have a removable lid for replacing the filter cartridge. The filter cartridge shall engage and secure into the filter housing with a 90° degree turn and shall have a double O-ring end seal to prevent bypassing of unfiltered water around the filter cartridge. The filter cartridge shall be a [[ pleated [1][5][20][50][150] micron]], [[ melt blown [1][5][20][50] micron]], [[pleated activated carbon 5 micron]] [[ activated carbon 0.5 micron]] The filter system shall not require electricity or water for backwashing. The feed water pressure must not exceed 125psi (8.6 bar). Water temperature must not fall below 34°F or exceed 125°F at 80psi (1 - 52°C).

## Feed Water Guidelines

Water Pressure Maximum . . . . . 125psi (8.6 bar)

Min/Max Water Temperature . . . 34 to 125°F / 1 to 52°C (125°F / 52°C at 80psi maximum pressure)

For all other guideline information please contact your Watts representative.

## Dimensions - Weights

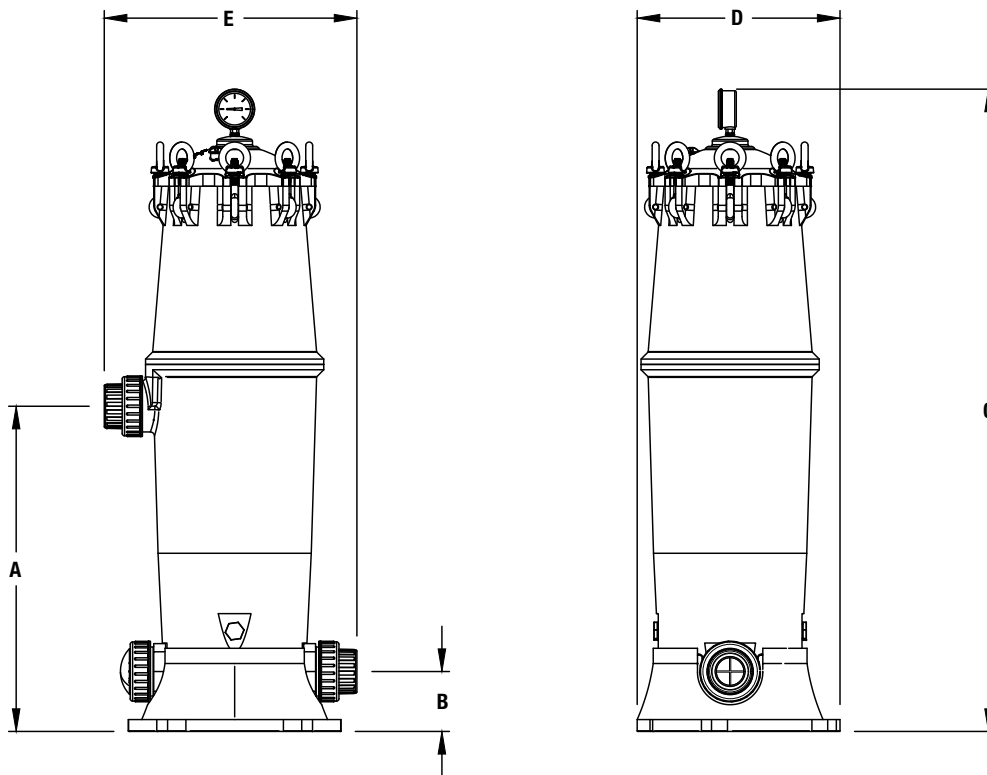

MODEL NO.	DIMENSIONS						WEIGHTS					
	A		B		C*		D		E		lbs	kgs
	in.	mm	in.	mm	in.	mm	in.	mm	in.	mm		
BBH-150	21 <sup>5</sup> / <sub>8</sub>	549	4	102	42 <sup>5</sup> / <sub>8</sub>	1082	13 <sup>1</sup> / <sub>2</sub>	343	16 <sup>3</sup> / <sub>4</sub>	426	39	18

\*Allow 36" of space above filter housing lid to facilitate filter cartridge replacement.

## Specifications

### Big Bubba Cartridge Filter Housing

HOUSING	DATA
Body	Glass reinforced PP
Gauge port	1/4" FNPT brass reinforced
Swing bolts	304 stainless steel
O-ring (lid)	EPDM
Inlet/Outlet Connections	2" slip PVC female
Overall height	42.7"
Width (vessel OD)	15.4"
Maximum temperature	125°F (52°C) @ 80 PSI
Maximum working pressure	125psi (8.6 bar)

### Big Bubba Filter Cartridges

CARTRIDGE	DATA
Max. flow rate* (Pleated)	150 GPM* (34 M3/hr.)
Max. flow rate (Melt Blown)	100 GPM (22.7 M3/hr.)
Max. flow rate (Activated Carbon Pleated)	15 GPM (3.4 M3/hr.)
Max. flow rate (Activated Carbon Block)	4 GPM (0.9 M3/hr.)
Cartridge end caps	Glass reinforced PP
O-rings (cartridge)	EPDM

\* Highly dependent on micron rating, solids content and other factors. Please see pressure drop chart below.

For filter material of construction, see Big Bubba Specifications chart below.

## Specifications

### Big Bubba Filter Cartridges

CARTRIDGE	PLEATED	MELT BLOWN	ACTIVATED CARBON PLEATED	ACTIVATED CARBON BLOCK
Media	PP*, PP Mesh**	PP	Pleated Activated Carbon	Activated Carbon Block
End caps	PP + FG	PP + FG	PP + FG	PP + FG
Center tubes	PP	PP	PP	NA
Maximum flow rate (GPM)	150	100	15	4
Maximum temperature	125°F (52°C)	125°F (52°C)	125°F (52°C)	125°F (52°C)
Maximum ΔP (psi)	30	40	30	40
Chemical resistance	Excellent	Excellent	Not a factor (for water only)	Not a factor (for water only)
Length (media)	26 1/4"	26 1/4"	26 1/4"	26 1/4"
O-rings (dual)	EPDM	EPDM	EPDM	EPDM
Shipping weight (lbs.)	5	5	5	20
Carton dimensions	7" x 7" x 31"	7" x 7" x 31"	7" x 7" x 31"	10.75" x 10.75" x 35"
Micron ratings	1* & 5*, 20*, 50*, 150**	1, 5, 20, 50	5	0.5

\*Polypropylene fabric

\*\*Polypropylene mesh screen

**Note:** Flow rates are based on each specific application, micron rating, solids content and a number of other factors. End user should consider these factors when selecting the filter housing (or number of filter housings) needed for their particular requirement.

## Low Pressure Drop

Big Bubba cartridge filter systems are designed to minimize pressure drop, by using 2" pipe fittings and large diameter center tubes. (See chart at right for pressure drop data using pleated cartridges.)

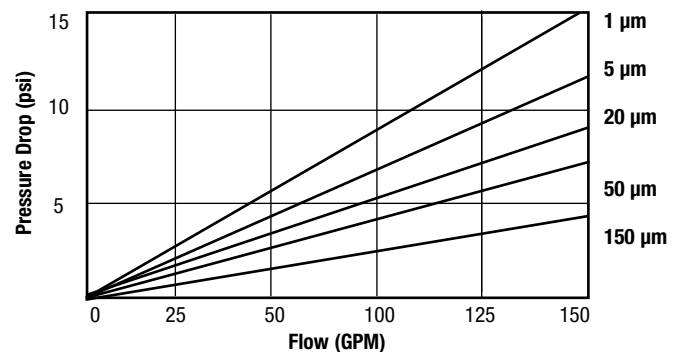

Pleated Sediment Filter Cartridge Flow Rate

## Ordering Information

### Filter Housings

MODEL NO.	ORDERING CODE	DESCRIPTION	PIPE SIZE	SPACE	WEIGHT	
				REQUIRED W X D X H	LBS	KGS
BBH-150	68100639	Big Bubba Filter Housing 2" with Gauge Port Lid and Pressure Gauge	2"	20" x 20" x 45"	39	18

### Filter Cartridges

MODEL NO.	ORDERING CODE	MEDIA TYPE	MICRON RATING	PER CASE	WEIGHT	
					LBS	KGS
BBC-150-P1	68100630	Pleated PP	1	1	5	2.3
BBC-150-P5	68100632	Pleated PP	5	1	5	2.3
BBC-150-P20	68100631	Pleated PP	20	1	5	2.3
BBC-150-P50	68100633	Pleated PP	50	1	5	2.3
BBC-150-PM150	68100634	Pleated PP Mesh	150	1	5	2.3
BC-150-D1	68100626	Melt Blown PP	1	1	5	2.3
BBC-150-D5	68100628	Melt Blown PP	5	1	5	2.3
BBC-150-D20	68100627	Melt Blown PP	20	1	5	2.3
BBC-150-D50	68100629	Melt Blown PP	50	1	5	2.3
BBC-150-ACP	68100625	Carbon Pleated	5	1	5	2.3
BB-C100	7100980	Carbon Block	0.5	1	20	9

Note: 5, 20, 50 and 150 micron pleated cartridges are cleanable and reusable to reduce costs.

MODEL NO.	ORDERING CODE	MAX. FLOW RATE	MAX CAPACITY	MAX. CHLORINE REDUCTION
BBC-150-ACP	68100625	15 GPM	140,000 Gals.	90%

Note: Maximum flow rate, capacity and chlorine reduction values listed above are estimates based on Watts' internal testing. Due to variances in feedwater quality and application variables, your results may differ.

MODEL NO.	ORDERING CODE	MAX. FLOW RATE	MAX CAPACITY	CONTAMINANTS REDUCED
BB-C100	7100980	4 GPM	84,480 Gals.	Lead, PFOS/PFOA, Cysts, Chlorine

Note: Using filter cartridge model number BB-C100 within an existing installed Big Bubba filter housing model number BBH-150, to achieve the reductions and capacities stated above, requires the purchase of Volumetric Flow Monitor model number BB-M100. The BB-C100 Filter Cartridge, together with BB-M100 Volumetric Flow Monitor and BBH-150 Filter Housing, is certified for the reduction of Lead, PFOS/PFOA, Cysts, and Chlorine Taste & Odors. For new installations purchase Model BB-S100 System which includes BBH-150, BB-C100 and BB-M100. See Watts Engineering Specification Sheet # ES-WQ-BB-S100 for additional BB-S100 system performance information.

### Components

MODEL NO.	ORDERING CODE	DESCRIPTION
BB-ADAPTER	68100608	Plumbing Adaptor 2" PVC Grey
BB-COUPLER-OR	68100611	O-ring for Filter Housing Coupler
BB-DPOR	68100612	O-ring for Drain Plug
BB-DRAINPLUG	68100613	Drain Plug 1/2" NPT
BB-ENDCAP	68100614	Filter Housing Coupler Cap 2" PVC Grey
BB-NUT	68100618	Plumbing Adapter Union Nut
BB-ORING-E	68100619	Filter Housing Lid O-ring
BB-PR-ASSY	68100621	Pressure Relief Button Assembly

#### NOTICE

Flow rates, dimensions, and capacities are per housing. Pipe size, system size, and space requirements are in inches.



Pleated

Melt Blown

Activated Carbon Pleated

Activated Carbon Block

### Four Filter Cartridge Types

#### Pleated Cartridges

Ideal for more critical applications, offering greater efficiency and more surface area for greater throughput and reduced cost.

#### Melt Blown Cartridges

Melt blown Polypropylene cartridges are recommended when depth filtration is necessary for the reduction of soft particulate.

#### Activated Carbon Pleated Cartridge

Activated carbon reduces chlorine tastes, odors and sediment. Ideal for whole home treatment to 15 GPM offering 140,000 gallon capacity.

#### Activated Carbon Block Cartridge

Big Bubba Carbon Block Filter Cartridge for the Reduction of Lead, PFOS/PFOA, Cysts, and Chlorine Taste & Odor is ideal for whole home point of entry applications.

#### NOTICE

The information contained herein is not intended to replace the full product installation and safety information available or the experience of a trained product installer. You are required to thoroughly read all installation instructions and product safety information before beginning the installation of this product.

