

Engineering Specification

Job Name _____

Contractor _____

Job Location _____

Approval _____

Engineer _____

Contractor's P.O. No. _____

Approval _____

Representative _____

SI-742-L Sediment & Hair Interceptor

Specification

Watts SI-742-L floor mounted or recessed epoxy coated steel large capacity sediment interceptor with gasketed epoxy coated steel skid-proof cover secured with hex head center bolt, removable stainless steel dual chamber basket, and 2" no hub connections. Maximum flow rate 30 GPM.

NOTE: SI-742-L requires 17" clearance above cover to remove sediment basket.



Call customer service if you need assistance with technical details.

Options	
Suffix	Description
-E	Extension
-O	Inlet & Outlet (other than standard)
-SS	All Stainless Steel
-THD	IPS Threaded Connections

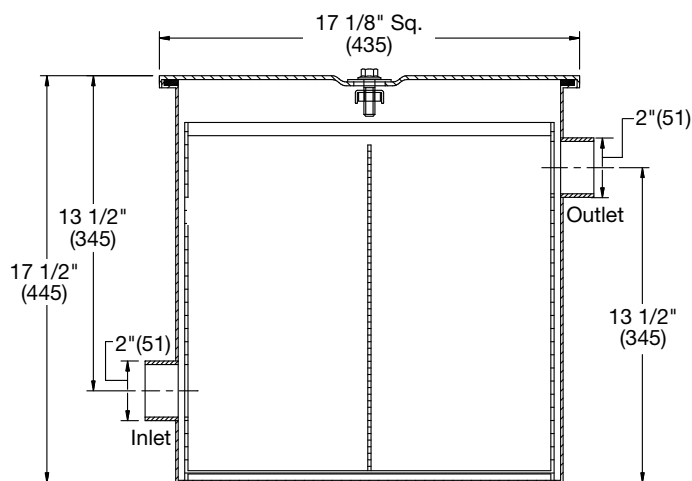

NOTICE

The information contained herein is not intended to replace the full product installation and safety information available or the experience of a trained product installer. You are required to thoroughly read all installation instructions and product safety information before beginning the installation of this product.

Watts product specifications in U.S. customary units and metric are approximate and are provided for reference only. For precise measurements, please contact Watts Technical Service. Watts reserves the right to change or modify product design, construction, specifications, or materials without prior notice and without incurring any obligation to make such changes and modifications on Watts products previously or subsequently sold.



USA: T: (800) 338-2581 • Watts.com

Canada: T: (888) 208-8927 • Watts.ca

Latin America: T: (52) 55-4122-0138 • Watts.com

ES-WD-SI-742-L 2602

© 2026 Watts

