

ACV Schematic

LEAD FREE***S115-74 (Globe)****Pressure Reducing Control Valve with Low Flow By-Pass****Features**

- Throttles to reduce high upstream pressure to constant lower downstream pressure
- Low Flow By-Pass controls at low flows
- Main Line valve controls at high flows
- Reducing and Low Flow By-Pass setpoints are separately adjustable

Standard Components

- 1 – Main Valve (Single Chamber)
- 2 – Pressure Reducing Control
- 3 – Fixed Orifice
- 4 – Low Flow By-Pass
- X – Isolation Cocks

Options and Accessories

- FC Flo-Clean Strainer (Standard 1¼" – 4")
- Y Y-Strainer (Replaces Flo-Clean)
- ACS Adjustable Closing Speed (Replaces Fixed Orifice)
- AOS Adjustable Opening Speed (Standard 1¼" – 4")
- P – Position Indicator
- L – Limit Switch

Operation

The ACV Pressure Reducing Control Valve with Low Flow By-Pass is designed to automatically reduce a fluctuating higher upstream pressure to a constant lower downstream pressure regardless of varying flow rates. It is controlled by a normally open, pressure reducing pilot designed to: 1) Open (allowing fluid out of the main valve cover chamber) when downstream pressure is below the adjustable setpoint, and 2) Close (allowing fluid to fill the main valve cover chamber) when downstream pressure is above the adjustable setpoint. A decrease in downstream pressure causes the valve to modulate toward an open position, raising downstream pressure. An increase in downstream pressure causes the valve to modulate toward a closed position, lowering downstream pressure.

A Low Flow By-Pass Valve is piped parallel to the Main Pressure Reducing Valve, and is set approximately 10 PSI higher. The Low Flow By-Pass handles flow requirements below the range of the Main Pressure Reducing Valve. During "off peak" demand conditions, the Low Flow By-Pass provides flow and pressure to the downstream zone. As flow requirements increase beyond the capacity of the Low Flow By-Pass, downstream pressure falls below the setpoint of the Main Pressure Reducing Valve allowing it to throttle toward open, supplementing flow and pressure. As flow requirements decrease, downstream pressure rises above the setpoint of the Main Pressure

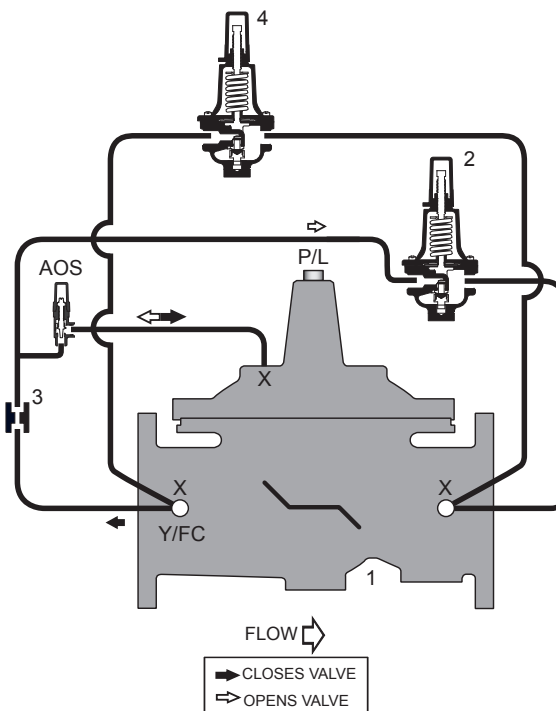

Reducing Valve, causing it to throttle toward closed, allowing the Low Flow By-Pass to resume command of flow and pressure.

***The wetted surface of this product contacted by consumable water contains less than 0.25% of lead by weight.**

NOTICE

The information contained herein is not intended to replace the full product installation and safety information available or the experience of a trained product installer. You are required to thoroughly read all installation instructions and product safety information before beginning the installation of this product.

Watts product specifications in U.S. customary units and metric are approximate and are provided for reference only. For precise measurements, please contact Watts Technical Service. Watts reserves the right to change or modify product design, construction, specifications, or materials without prior notice and without incurring any obligation to make such changes and modifications on Watts products previously or subsequently sold.

USA: Tel: (713) 943-0688 • Fax: (713) 944-9445 • Watts.com

Canada: Tel: (905) 332-4090 • Fax: (905) 332-7068 • Watts.ca

Latin America: Tel: (52) 81-1001-8600 • Fax: (52) 81-8000-7091 • Watts.com

WATTS®

A Watts Water Technologies Company