

Watts Regulator Examines Product Applications for
The 2000 Uniform Plumbing Code



INTRODUCTION

We are pleased to present to you excerpts from the most recent edition of the Uniform Plumbing Code along with applicable specifications for Watts Regulator products that apply to these sections. Excerpts of the Uniform Plumbing Code 2000 are presented as extracts at the

top of the page along with engineering specifications for Watts Regulator Company products that comply with the corresponding UPC Code requirements at the bottom.

TABLE OF CONTENTS

Chapter 4		Plumbing Fixtures and Fixture Fittings
Section	407	Special Fixtures and Specialties
	407.1	Water Connections 4
Section	417	Bidets 5
	417.2	Backflow Protection 5
Chapter 5		Water Heaters
Section	510	Protection from Damage
	510.1 6
	510.4 6
	510.5 6
Chapter 6		Water Supply and Distribution
Section	602	Unlawful Connections
	602.1 7
	602.2 7
	602.3 7
	602.4 7
Section	603	Cross-Connection Control
	603.1	Approval of Devices or Assemblies 8
Section	603.2	Backflow Prevention Devices, Assemblies and Methods
	603.2.2	Atmospheric Vacuum Breaker (AVB) 9
	603.2.3	Hose Connection Backflow Preventer 9
	603.2.4	Double Check Valve Backflow Prevention Assembly (DC) 10
	603.2.5	Pressure Vacuum Breaker Backflow Prevention Assembly (PVB) 11
	603.2.6	Pressure Vacuum Breaker Spill-Proof Type Backflow Prevention Assembly (SVB) 12
	603.2.7	Reduced Pressure Principle Backflow Prevention Assembly (RP) 12
Section	603.3	General Requirements
	603.3.1 13
	603.3.3 13
	603.3.5 13
	603.3.6 14
	603.3.8 14, 15
Section	603.4	Specific Requirements
	603.4.2 15
	603.4.3 15
	603.4.5 16
Section	603.4.6	Protection from Lawn Sprinklers and Irrigation Systems
	603.4.6.1 17, 18
	603.4.6.2 17, 18
	603.4.6.3 17, 18
	603.4.6.4 17, 18
Section	603.4.7	Potable Water Outlets with Hose Attachments 19
	603.4.9	Water Cooled Compressors, Degreasers 20
	603.4.10	Water Inlets to Water Supplied Aspirators 20
	603.4.11	Potable Water Make Up Connections to Steam or Hot Water Boilers 21
	603.4.13	Potable Water Supply to Carbonators 22
	603.4.16	Deck-Mounted or Equipment-Mounted Vacuum Breakers 22
Section	603.4.18	Protection from Fire Systems

	603.4.18.1	23, 24
	603.4.18.2	25 - 26
	603.4.18.3	25 - 26
	603.4.18.4	25 - 26
	603.4.18.5	Residential Sprinkler Systems.....	26, 27
Section	603.4.19	Special Equipment, Water Supply Protection.....	27, 28
Section	603.4.20	Portable Cleaning Equipment, Dental Vacuum Pumps.....	27, 28
Section	603.4.21	Water Heater Connectors.....	28
Section	605	Valves.....	28
	605.1	28
	605.2	28
	605.3	28
	605.4	28
	605.5	28
	605.7	28
Section	608	Water Pressure, Pressure Regulators, Pressure Relief Valves and Vacuum Relief Valves	
	608.1	Inadequate Water Pressure.....	30
	608.2	Excessive Water Pressure.....	30, 31
	608.3	32
	608.4	33
	608.5	33
	608.6	34
	608.7	34
Section	609	Installation, Testing, Unions and Location	
	609.5	Unions.....	35
	609.8	Low Pressure Cutoff Required on Booster Pumps for Water Distribution Systems.....	35
	609.10	Water Hammer.....	36
Chapter 10		Traps and Interceptors	
Section	1007.0	Trap Seal Protection.....	37
Chapter 13		Health Care Facilities and Medical Gas and Vacuum Systems	
Section	1308	Aspirators.....	38
	1308.1	Water Inlets to Water Supplied Aspirators.....	38
Backflow Prevention Guide		39, 40

NOTE:

All Watts Regulator Company engineering specifications shown on the following pages are for products that comply with the corresponding UPC Code requirements above them. Watts reserves the right to change or modify product design, construction, specifications, or materials without prior notice and without incurring any obligation to make such changes and modifications on Watts products previously or subsequently sold.

Reproduced from the 2000 edition of the the Uniform Plumbing Code™, copyright 1999, with permission of the publisher, the International Association of Plumbing and Mechanical Officials. All rights reserved.

UPC 2000 Section 407 Special Fixtures and Specialties

407.1 Water Connection. Baptisteries, ornamental and lily ponds, aquaria, ornamental fountain basins, and similar constructions when provided with water supplies shall be protected from back-siphonage.

Applicable Watts Product for UPC Code Section 407.1:

WATTS SERIES 009

Reduced Pressure Zone Backflow Preventer (1/4" - 3")

Specifications:

A reduced pressure zone backflow preventer shall be installed at each potential health hazard location to prevent backflow due to backsiphonage and/or backpressure. The assembly shall consist of an internal pressure differential relief valve located in a zone between two positive seating check modules with captured springs and silicone seat discs. Seats and seat discs shall be replaceable in both check modules and the relief valve. There shall be no threads or screws in the waterway exposed to line fluids. Service of all internal components shall be through a single access cover secured with stainless steel bolts. The assembly shall also include two resilient seated isolation valves, four resilient seated test cocks and an air gap drain fitting. The assembly shall meet the requirements of: USC Manual 8th Edition; ASSE Standard. 1013; AWWA Standard. C511; CSA B64.4. The valve shall be a Watts Regulator Company Series 009.

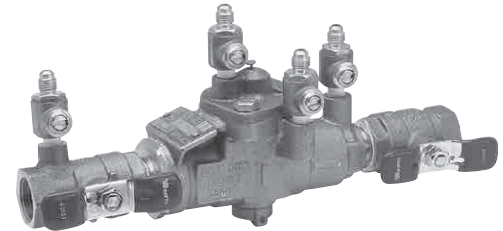

Watts Series 009

Applicable Watts Product for UPC Code Section 407.1:

WATTS SERIES 288A

Hot or Cold Water Anti-Siphon Vacuum Breaker (1/4" - 3")

Specifications:

An atmospheric-type anti-siphon vacuum breaker shall be installed where indicated on the plans to prevent the back-siphonage of contaminated water. This device is not to be used under continuous pressure or where there is a possibility that a back-pressure condition may develop. The device shall meet the requirements of ASSE Standard 1001, ANSI A112.1.1 and CSA B64, and shall be a Watts Regulator Company Series 288A.



Watts Series 288A

Applicable Watts Product for UPC Code Section 407.1:

WATTS SERIES 008PCQT

Health Hazard Vacuum Breaker, Anti-Siphon, Spill Resistant (3/8" - 1")

Specifications:

A spill-resistant vacuum breaker (SVB) shall be installed in accordance with the manufacturer's instructions, as noted on the plans. The valve shall consist of a one-piece modular check and float assembly made of engineered thermoplastic and housed in a bronze body. Springs shall be stainless steel. The valve shall be constructed with a molded diaphragm separating the air inlet from the potable water supply to prevent spillage. The valve shall be a Watts Regulator Company Series 008PCQT.



Watts Series 008PCQT

UPC 2000 Section 417 Bidets

417.2 Backflow Protection. The water supply to the bidet shall be protected according to Chapter 6, which allows for an airgap or vacuum breaker.

Applicable Watts Product for UPC Code Section 417.2:

WATTS SERIES 009

Reduced Pressure Zone Backflow Preventer (1/4" - 3")

Specifications:

A reduced pressure zone backflow preventer shall be installed at each potential health hazard location to prevent backflow due to backsiphonage and/or backpressure. The assembly shall consist of an internal pressure differential relief valve located in a zone between two positive seating check modules with captured springs and silicone seat discs. Seats and seat discs shall be replaceable in both check modules and the relief valve. There shall be no threads or screws in the waterway exposed to line fluids. Service of all internal components shall be through a single access cover secured with stainless steel bolts. The assembly shall also include two resilient seated isolation valves, four resilient seated test cocks and an air gap drain fitting. The assembly shall meet the requirements of: USC Manual 8th Edition; ASSE Standard. 1013; AWWA Standard. C511; CSA B64.4. The valve shall be a Watts Regulator Company Series 009.

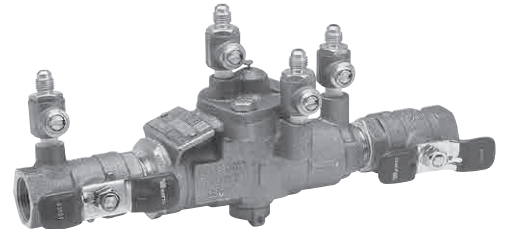

Watts Series 009

Applicable Watts Product for UPC Code Section 417.2:

WATTS SERIES 008PCQT

Health Hazard Vacuum Breaker, Anti-Siphon, Spill Resistant (3/8" - 1")

Specifications:

A spill-resistant vacuum breaker (SVB) shall be installed in accordance with the manufacturer's instructions, as noted on the plans. The valve shall consist of a one-piece modular check and float assembly made of engineered thermoplastic and housed in a bronze body. Springs shall be stainless steel. The valve shall be constructed with a molded diaphragm separating the air inlet from the potable water supply to prevent spillage. The valve shall be a Watts Regulator Company Series 008PCQT.



Watts Series 008PCQT

UPC 2000 CODE - CHAPTER 5 - WATER HEATERS

UPC 2000 Section 510 Protection from Damage

510.1 Water heaters generating a glow, spark or flame capable of igniting flammable vapors may be installed in a garage, provided the pilots, burners or heating elements and switches are at least eighteen (18) inches (457 mm) above floor level.

510.4 The Administrative Authority may require the use of an approved dielectric insulator on water piping connections of water heaters and related water heating equipment.

510.5 In seismic zones 3 and 4, water heaters shall be anchored or strapped to resist horizontal displacement due to earthquake motion. Strapping shall be at points within the upper one-third (1/3) and lower one-third (1/3) of its vertical dimensions. At the lower point, a minimum distance of four (4) inches (102 mm) shall be maintained above the controls with the strapping.

Applicable Watts Products for UPC Code Section 510.1:

WATTS MODELS AS-20, AS-22, AS-26, AS-30, DPS-20 AND ENS-20

Water Heater Stands

Specifications:

Watts/Spacemaker water heater stands, models AS-20, AS-22, AS-26, AS-30, or drip pan stand, DPS-20 or Enclosed Stand, Model ENS-20 shall be used in garages to raise water heater flame element 18" above the floor. Construction shall be of galvanized steel for safety and strength and to resist rotting, melting or burning. All models use floating seismic clips to secure stand to wall studs.



Watts DPS-20

Applicable Watts Product for UPC Code Section 510.4:

WATTS SERIES 3000

Dielectric Pipe Fittings/Unions

Specifications:

All piping of dissimilar metals shall be joined with a dielectric union. All threaded unions must be rated minimum 210°F @ 250psi (Gasket GA) water, air, oil, natural gas, propane, gasoline, kerosene, mineral oil, and alkalines. Gasket (GB) Steam 200°F, 50psi. Flanged fittings 300°F, 175psi. Meet the requirements of ANSI B16.39. Must withstand a minimum of 600 volts on a dry line with no flash over. All connections must be verified for temperature, pressure and media requirements. "Dielectric Nipples" shall be unacceptable. The fittings shall be Watts Regulator Company Series 3000.



Watts Series 3000

Applicable Watts Products for UPC Code Section 510.5:

WATTS MODELS E-50, E-100, E-75, E-120, TSE-75 AND TSE-75P

Water Heater Restraints

Specifications:

Watts/Spacemaker water heater restraints, models E-50, E-100, E-75, E-120, TSE-75 or TSE-75P shall be used to strap the water heater securely to the wall using lag bolts. Construction shall be of galvanized steel for safety and strength.

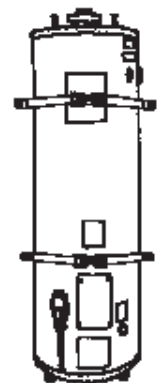

Watts TSE-75

UPC 2000 Section 602 Unlawful Connections

602.1 No installation of potable water supply piping or part thereof shall be made in such a manner that it will be possible for used, unclean, polluted or contaminated water, mixtures, or substances to enter any portion of such piping from any tank, receptor, equipment, or plumbing fixture by reason of back-siphonage, by suction or any other cause, either during normal use and operation thereof or when any such tank, receptor, equipment, or plumbing fixture is flooded, or subject to pressure in excess of the operating pressure in the hot or cold water piping.

602.2 No person shall make a connection or allow one to exist between pipes or conduits carrying domestic water supplied by any public or private water service system, and any pipes, conduits, or fixtures containing or carrying water from any other source or containing or carrying water which has been used for any purpose whatsoever, or any piping carrying chemicals, liquids, gases, or any substances whatsoever, unless there is provided a backflow prevention device approved for the potential hazard and maintained in accordance with this Code.

602.3. No plumbing fixture, device, or construction shall be installed or maintained or shall be connected to any domestic water supply when such installation or connection may provide a possibility of polluting such water supply or may provide a cross-connection between a distributing system of water for drinking and domestic purposes and water which may become contaminated by such plumbing fixture, device, or construction unless there is provided a backflow prevention device approved for the potential hazard.

602.4 No water piping supplied by any private water supply shall be connected to any other source of supply without the approval of the Administrative Authority, Health Department, or other Department Having Jurisdiction.

See Backflow Prevention Guide on pages 39 – 40.

**Table 6-2
Backflow Prevention Devices, Assemblies and Methods**

Device, Assembly or Method ¹	Degree of Hazard				Installation ^{2,3}
	Pollution (Low Hazard)		Contamination (High Hazard)		
	Back-Siphonage	Back-Pressure	Back-Siphonage	Back-Pressure	
Airgap	X		X		See table in this chapter.
Atmospheric Vacuum Breaker	X		X		Upright position. No valves downstream. Minimum of six (6) inches (152 mm) or listed distance above all downstream piping and flood level rim of receptor. ^{4,5}
Spill-Proof Pressure-Type Vacuum Breaker	X		X		Upright position. Minimum of six (6) inches (152 mm) or listed distance above all downstream piping and flood level rim of receptor. ⁵
Double Check Valve Backflow Preventer	X	X			Horizontal, unless otherwise listed. Requires one (1) foot (305 mm) minimum clearance at bottom for maintenance. May need platform/ladder for test and repair. Does not discharge water.
Pressure Vacuum Breaker	X		X		Upright position. May have valves downstream. Minimum of twelve (12) inches (305 mm) above all downstream piping and flood level rim of receptor. May discharge water.
Reduced Pressure Principle Backflow Preventer	X	X	X	X	Horizontal, unless otherwise listed. Requires one (1) foot (305 mm) minimum clearance at bottom for maintenance. May need platform/ladder for test and repair. May discharge water.

¹ See description of devices and assemblies in this chapter.

² Installation in pit or vault requires previous approval by the Administrative Authority.

³ Refer to general and specific requirements for installation.

⁴ Not to be subjected to operating pressure for more than 12 hours in any 24 hour period.

⁵ For deck-mounted and equipment-mounted vacuum breakers, see Section 603.4.16

UPC 2000 Section 603 Cross Connection Control

Cross-connection control shall be provided in accordance with the provisions of this chapter.

No person shall install any water operated equipment or mechanism, or use any water treating chemical or substance, if it is found that such equipment, mechanism, chemical or substance may cause pollution or contamination of the domestic water supply. Such equipment or mechanism may be permitted only when equipped with an approved backflow prevention device or assembly.

603.1 Approval of Devices or Assemblies. No person shall make a connection or allow one to exist between pipes or conduits carrying domestic water supplied by any public or private water service system, and any pipes, conduits, or fixtures containing or carrying water from any other source or containing or carrying water which has been used for any purpose whatsoever, or any piping carrying chemicals, liquids, gases, or any substances whatsoever, unless there is provided a backflow prevention device approved for the potential hazard and maintained in accordance with this Code.

See Backflow Prevention Guide on pages 39 – 40.

UPC 2000 Section 603.2 Backflow Prevention Devices, Assemblies and Methods

603.2.2 Atmospheric Vacuum Breaker (AVB). An atmospheric vacuum breaker consists of body, a checking member and an atmospheric opening.

603.2.3 Hose Connection Backflow Preventer. Consists of two independent check valves with an independent atmospheric vent between and a means of field testing and draining.

Applicable Watts Product for UPC Code Section 603.2.2:

WATTS SERIES 288A

Hot or Cold Water Anti-Siphon Vacuum Breaker ($1/4'' - 3''$)

Specifications:

An atmospheric-type anti-siphon vacuum breaker shall be installed where indicated on the plans to prevent the back-siphonage of contaminated water. This device is not to be used under continuous pressure or where there is a possibility that a back-pressure condition may develop. The device shall meet the requirements of ASSE Standard 1001, ANSI A112.1.1 and CSA B64, and shall be a Watts Regulator Company Series 288A.



Watts Series 288A

Applicable Watts Product for UPC Code Section 603.2.3:

WATTS SERIES 8FR

Hose Connection Vacuum Breakers ($3/4''$)

Specifications:

A hose connection type anti-siphon vacuum breaker shall be installed where indicated on the plans to prevent the back-siphonage of contaminated water. This device is not to be used under continuous pressure or where there is a possibility that a back pressure condition may develop. This device shall meet the requirements of ANSI A112.1.3, ASSE Standard 1011 and offer freeze protection even with a hose attached. The valve shall be a Watts Regulator Company Series 8FR.



Watts Series 8FR

Applicable Watts Product for UPC Code Section 603.2.3:

WATTS SERIES 9D

Backflow Preventer with Intermediate Atmospheric Vent ($1/2'' - 3/4''$)

Specifications:

Important: Inquire with governing authorities for local installation requirements. A Dual Check with Atmospheric Vent shall be installed at referenced cross-connections. Valve shall feature stainless steel and rubber internals protected by an integral strainer. Primary check shall be rubber to rubber seated, backed by the secondary check with rubber to metal seating. The device shall be ASSE approved under Standard. 1012 and shall be a Watts Regulator Company Series 9D.



Watts Series 9D

UPC 2000 Section 603.2 Backflow Prevention Devices, Assemblies and Methods - cont'd

603.2.4 Double Check Valve Backflow Prevention Assembly (DC). A double check valve backflow prevention assembly consists of two independently acting internally loaded check valves, four properly located test cocks and two isolation valves.

Applicable Watts Product for UPC Code Section 603.2.4:

WATTS SERIES 007

Double Check Valve Assembly (1/2" - 3")

Specifications:

A double check valve backflow preventer shall be installed at each noted location. The assembly shall consist of two positive seating check modules with captured springs and rubber seat discs. The check module seats and seat discs shall be replaceable. Service of all internal components shall be through a single access cover secured with stainless steel bolts. The assembly shall also include two resilient seated isolation valves; four top mounted, resilient seated test cocks. The assembly shall meet the requirements of ASSE Standard 1015 and AWWA Standard C510. Approved by the Foundation for Cross-Connection Control and Hydraulic Research at the University of Southern California. The valve shall be a Watts Regulator Company Series 007.



Watts Series 007

Applicable Watts Product for UPC Code Section 603.2.4:

WATTS SERIES 709

Double Check Valve Backflow Preventer (2 1/2" - 10")

Specifications:

A double check valve backflow preventer shall be installed at referenced cross-connections to prevent the backflow of polluted water into the potable water supply. The cross-connections shall be determined by local inspection authority for use where a high hazard situation does not exist. Valve shall feature modular check assemblies with center stem guiding. Each check module shall have a captured spring and be accessible through a bolted cover plate. Seats shall be replaceable without special tools. It shall be a complete assembly including tight-closing resilient seated shut-off valves, test cocks, and a strainer is recommended. The assembly shall meet the requirements of ASSE No. 1015; AWWA C510-92; CSA B64.5 and UL Classified File No. EX3185. Approved by the Foundation for Cross-Connection Control and Hydraulic Research at the University of Southern California. The valve shall be a Watts Regulator Company Series 709.

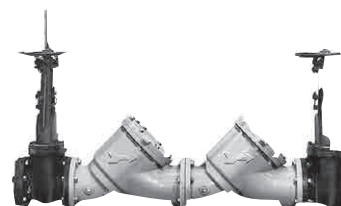

Watts Series 709

Applicable Watts Product for UPC Code Section 603.2.4:

WATTS SERIES 709DCDA

Double Check Detector Assembly Backflow Preventer (3", 4", 6", 8", 10")

Specifications:

A double check detector assembly backflow preventer shall be installed on fire protection systems when connected to a potable water supply. Degree of hazard present is determined by the local authority having jurisdiction. The unit shall be a complete assembly including UL listed resilient seated OS&Y shutoff valves and test cocks. The unit shall be UL/FM approved with UL/FM approved OS&Y shutoff valves. The auxiliary line shall consist of an approved backflow preventer and water meter. The assembly shall meet the basic requirements of ASSE 1048; AWWA Standard C510 for Double Check Valves. Approved by the Foundation for Cross-Connection Control and Hydraulic Research at the University of Southern California. The valve shall be a Watts Regulator Company Series 709DCDA OSY.

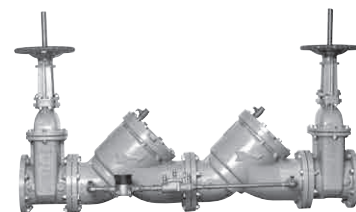

Watts Series 709DCDA

UPC 2000 Section 603.2 Backflow Prevention Devices, Assemblies and Methods - cont'd

603.2.5 Pressure Vacuum Breaker Backflow Prevention Assembly (PVB). A pressure vacuum breaker backflow prevention assembly consists of a loaded air inlet valve, an internally loaded check valve, two (2) properly located test cocks and two (2) isolation valves. This device shall be installed outdoors only unless provisions for spillage are provided.

Applicable Watts Product for UPC Code Section 603.2.5:

WATTS SERIES 800M4FR

Freeze-Resistant Pressure Vacuum Breaker (1/2" - 2")

Specifications:

An anti-siphon pressure vacuum breaker shall be installed where indicated on the plans to prevent the back-siphonage of contaminated water. This assembly is not to be used where there is a possibility that a back pressure condition may develop. The assembly will incorporate an acetal bonnet with silicone rubber O-ring seal and silicone rubber seat disc. The valve shall have replaceable seats. Check assembly shall be guided over its full stroke by 'V' notch guides. The assembly shall include an internal, built-in relief valve designed to protect the internal components and the backflow body from freezing. The relief valve action shall be repeatable, automatically re-seating when the pressure within the valve is below the set point of the freeze relief valve. The assembly shall meet the requirements of ANSI/ASSE Standard 1020. The valve shall be a Watts Regulator Company Series 800M4FR.



Watts Series 800M4FR

Applicable Watts Product for UPC Code Section 603.2.5:

WATTS SERIES 800M4QT

Anti-siphon Pressure Vacuum Breakers (1/2" - 2")

Specifications:

A pressure anti-siphon vacuum breaker shall be installed where indicated on the plans to prevent the back siphonage of contaminated water. This assembly is not to be used where there is a possibility that a back pressure condition may develop. The assembly will incorporate an acetal bonnet with silicone rubber O-ring seal and silicone rubber seat disc. The valve shall have replaceable seats. Check assembly shall be guided over its full stroke by 'V' notch guides. The assembly shall meet the requirements of ANSI/ASSE Standard 1020. The valve shall be a Watts Regulator Company Series 800M4QT.



Watts Series 800M4QT

UPC 2000 Section 603.2 Backflow Prevention Devices, Assemblies and Methods - cont'd

603.2.6 Pressure Vacuum Breaker Spill-Proof Type Backflow Prevention Assembly (SVB). A pressure type vacuum breaker backflow prevention assembly consists of one (1) check valve force-loaded closed and an air inlet vent valve force-loaded open to atmosphere, positioned downstream of the check valve, and located between and including two (2) tightly closing shut-off valves and test cock(s).

603.2.7 Reduced Pressure Principle Backflow Prevention Assembly (RP). A reduced pressure principle backflow prevention assembly consists of two independently acting internally loaded check valves, a differential pressure relief valve, four properly located test cocks and two isolation valves.

Applicable Watts Product for UPC Code Section 603.2.6:

WATTS SERIES 008PCQT

Health Hazard Vacuum Breaker, Anti-Siphon, Spill Resistant ($3/8"$ - $1"$)

Specifications:

A spill-resistant vacuum breaker (SVB) shall be installed in accordance with the manufacturer's instructions, as noted on the plans. The valve shall consist of a one-piece modular check and float assembly made of engineered thermoplastic and housed in a bronze body. Springs shall be stainless steel. The valve shall be constructed with a molded diaphragm separating the air inlet from the potable water supply to prevent spillage. The valve shall be a Watts Regulator Company Series 008PCQT.



Watts Series 008PCQT

Applicable Watts Product for UPC Code Section 603.2.7:

WATTS SERIES 909

Reduced Pressure Zone Backflow Preventer ($3/4"$ - $2"$)

Specifications:

A reduced pressure zone backflow preventer shall be installed at each cross connection to prevent backsiphonage and back-pressure backflow of hazardous materials into the potable water supply. The assembly shall consist of a pressure differential relief valve located in a zone between two positive seating check valves. Back-siphonage protection shall include provision to admit air directly into the reduced pressure zone via a separate channel from the water discharge channel, or directly into the supply pipe via a separate vent. The assembly shall include two resilient seated shutoff valves before and after the assembly, test cocks and a protective strainer upstream of the No. 1 shutoff valve. The assembly (specify Model 909 for temperatures up to 140°F (60°C) or Model 909HW for temperatures up to 210°F (99°C)) shall meet the requirements of ASSE Standard 1013; AWWA Standard C-511-92 CSA B64.4; FCCCHR of USC Manual Section 10. Listed by IAPMO (UPC). SBCCI (Standard Plumbing code). The valve shall be a Watts Regulator Company Series 909QT or 909QTHW.

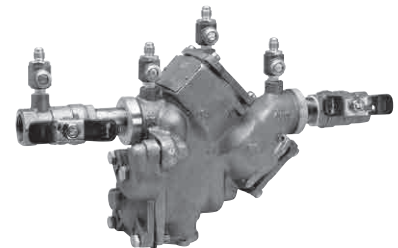

Watts Series 909

Applicable Watts Product for UPC Code Section 603.2.7:

WATTS SERIES 009

Reduced Pressure Zone Backflow Preventer ($1/4"$ - $3"$)

Specifications:

A reduced pressure zone backflow preventer shall be installed at each potential health hazard location to prevent backflow due to backsiphonage and/or backpressure. The assembly shall consist of an internal pressure differential relief valve located in a zone between two positive seating check modules with captured springs and silicone seat discs. Seats and seat discs shall be replaceable in both check modules and the relief valve. There shall be no threads or screws in the waterway exposed to line fluids. Service of all internal components shall be through a single access cover secured with stainless steel bolts. The assembly shall also include two resilient seated isolation valves, four resilient seated test cocks and an air gap drain fitting. The assembly shall meet the requirements of: USC Manual 8th Edition; ASSE Standard 1013; AWWA Standard C511; CSA B64.4. The valve shall be a Watts Regulator Company Series 009.



Watts Series 009

UPC 2000 Section 603.3 General Requirements

603.3.1 All assemblies shall conform to listed standards and be acceptable to the Administrative Authority having jurisdiction over the selection and installation of backflow prevention assemblies.

603.3.3 The premise owner or responsible person shall have the backflow prevention assembly tested by a certified backflow assembly tester at the time of installation, repair, or relocation and at least on an annual schedule thereafter or more often when required by the Administrative Authority. The periodic testing shall be performed in accordance with the procedures in Table 14-1 by a tester qualified in accordance with those standards.

603.3.5 Direct connections between potable water piping and sewer connected wastes shall not exist under any conditions with or without backflow protection. Where potable water is discharged to the drainage system it shall be by means of an approved airgap of two (2) pipe diameters of the supply inlet, but in no case shall the gap be less than one (1) inch (25 mm). Connection may be made to the inlet side of a trap provided that an approved vacuum breakers is installed not less than six (6) inches (152 mm) or the distance according to the device's listing, above the flood level rim of such trapped fixture, so that at no time will any such device be subjected to any back-pressure.

Applicable Watts Product for UPC Code Section 603.3.3:

WATTS MODEL TK-DL

Test Kit with Digital Print Out

Specifications:

Backflow preventer test kit shall be of solid state construction with digital display, thermal tape printout, downloading capability, 16 key input keyboard, and 32K of battery backed up memory. Test kit shall come complete with carrying case, carrying strap, AC charger, a kit of brass adapters, three 6 foot color coded hoses, instructions, warranty, and operation manual. Test kit shall be a Watts Regulator Company model TK-DL.



Watts TK-DL

Applicable Watts Product for UPC Code Section 603.3.5:

AIR GAP

Specifications:

Air gap shall be installed where indicated on the plans to protect the potable water supply. Air gap shall provide unobstructed, physical separation between the discharge end of a potable water supply line and an open receiving vessel. Air gap shall be a Watts Regulator Company air gap.



Watts Air Gap

UPC 2000 Section 603.3 General Requirements - cont'd

603.3.6 Backflow preventers for hot water over 110°F (43.3°C) shall be a listed type designed to operated at temperatures of 110°F (43.3°C) or more without rendering any portion of the assembly inoperative.

603.3.8 In cold climate areas, backflow assemblies and devices shall be protected from freezing by a method acceptable to the Administrative Authority.

Applicable Watts Product for UPC Code Section 603.3.6:

WATTS SERIES 909QT-HW

Reduced Pressure Zone Backflow Preventer (3/4" - 2")

Specifications:

A reduced pressure zone backflow preventer shall be installed at each cross connection to prevent backsiphonage and back-pressure backflow of hazardous materials into the potable water supply. The assembly shall consist of a pressure differential relief valve located in a zone between two positive seating check valves. Back-siphonage protection shall include provision to admit air directly into the reduced pressure zone via a separate channel from the water discharge channel, or directly into the supply pipe via a separate vent. The assembly shall include two resilient seated shutoff valves before and after the assembly, test cocks and a protective strainer upstream of the No. 1 shutoff valve. The assembly (specify Model 909 for temperatures up to 140°F (60°C) or Model 909HW for temperatures up to 210°F (99°C) shall meet the requirements of ASSE Standard. 1013; AWWA Standard. C-511-92 CSA B64.4; FCCCHR of USC Manual Section 10. The valve shall be a Watts Regulator Company Series 909QTHW.

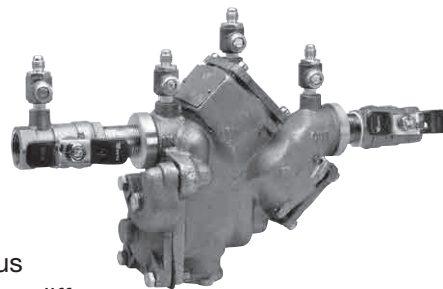

Watts Series 909HW

Applicable Watts Product for UPC Code Section 603.3.8:

WATTS SERIES WB

Insulated Enclosures

Specifications:

Backflow preventer assemblies subjected to potential freezing conditions shall be protected with the WattsBox enclosure as shown in the accompanying plan. Enclosure shall be designed for 12" clearance between valve and grade. The enclosure shall be of reinforced aluminum or fiberglass construction, providing access through doors and/or a hinged lid for testing/certification purposes. It must also be totally removable for maintenance purposes. The enclosure shall be structurally lined with a unicellular, non-wicking insulation consisting of a sandwich laminate or applied by spray. It shall contain a thermostatically controlled heat source mounted to the interior wall or on the backflow preventer to provide protection to -30°F. No wood or "particle board" shall be allowed in assembly. Insulation mounted with glue will be cause for rejection. Power source will be protected with a ground fault circuit interrupting receptacle, UL Standard 943, NEMA 3R, installed by others, inside the box. The enclosure shall contain drain openings sized to accommodate the maximum discharge of the reduced pressure assembly. Drain openings shall open to discharge under the most severe conditions. These openings are protected against intrusion of either wind, debris or animal. The enclosure is provided with means of permanent anchor and "lockable" access doors and/or lid to prohibit theft or vandalism. The enclosure shall be factory assembled and delivered to the site ready to install with no drilling, screwing or riveting of enclosure required on site. The enclosure and the backflow preventer shall be covered by a single warranty policy. The enclosure shall be a Watts Regulator Company Series WB.

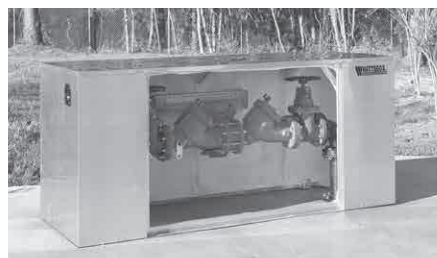

Watts Series WB

UPC 2000 Section 603.3 General Requirements - cont'd

Applicable Watts Product for UPC Code Section 603.3.8 (cont'd):

WATTS SERIES WB-T

Tall Insulated Enclosures

Specifications:

Backflow prevention assemblies subjected to potential freezing conditions shall be protected with the WattsBox enclosure as shown in the accompanying plan. The enclosure shall be of reinforced aluminum or fiberglass construction, providing access through doors and/or a hinged lid for testing/certification purposes. It must also be totally removable for maintenance purposes. The enclosure shall be structurally lined with a unicellular, non-wicking insulation consisting of a sandwich laminate or applied by spray. It shall contain a thermostatically controlled heat source mounted to the interior wall or on the backflow preventer to provide protection to -30°F. No wood or "particle board" shall be allowed in assembly. Insulation mounted with glue will be cause for rejection. Power source will be protected with a ground fault circuit interrupting receptacle, UL Standard 943, NEMA 3R, installed by others, inside the box. The enclosure shall contain drain openings sized to accommodate the maximum discharge of the reduced pressure assembly. Drain openings shall open to discharge under the most severe conditions. These openings are protected against intrusion of either wind, debris or animals. The enclosure is provided with means of permanent anchor and "lockable" access doors and/or lid to prohibit theft or vandalism. All "wet" portions of the backflow prevention assembly shall be protected within the enclosure. Fire department hose connections and OS&Y indicating valve handles shall be maintained outside the enclosure. The enclosure and the backflow preventer shall be covered by a single warranty policy. The enclosure shall be a Watts Regulator Company Series WB-T.

UPC 2000 Section 603.4 Specific Requirements

603.4.2 Water Closet and Urinal Tanks shall be equipped with a listed ballcock. The ballcock shall be installed with the critical level at least one (1) inch (25.4mm) above the full opening of the overflow pipe. In cases where the ballcock has no hush tube, the bottom of the water supply inlet shall be installed one (1) inch (25.4mm) above the full opening of the overflow pipe.

603.4.3 Water Closet Flushometer Tanks shall be protected against backflow by an approved backflow prevention assembly, device or method.

Applicable Watts Product for UPC Code Section 603.4.2 and 603.4.3:

WATTS SERIES GOVERNOR 80

Ball Cock and Thermal Expansion Relief Valve (10", 11 1/2", 12 1/2")

Specifications:

The valve shall be tested and certified under ASSE Standard 1002 and meet IAPMO, and CSA requirements for anti-siphon ball cocks. All materials in contact with water shall be FDA approved under DVR-21-177-2600. The thermal expansion relief valve shall be standardly set at 80psi to meet existing codes and shall be non-adjustable. The valve shall be a Watts Regulator Company Series Governor 80.



Watts Series Governor 80®

UPC 2000 Section 603.4 Specific Requirements - cont'd

603.4.5 Water supply inlets to tanks, vats, sumps, swimming pools and other receptors shall be protected by one of the following means.

1. An approved airgap;
2. A listed vacuum breaker installed on the discharge side of the last valve with the critical level not less than six (6) inches (152 mm) or in accordance with its listing;
3. A backflow preventer suitable for the contamination or pollution, installed in accordance with the requirements for that type of device or assembly as set forth in this chapter.

Applicable Watts Product for UPC Code Section 603.4.5:

WATTS SERIES 009

Reduced Pressure Zone Backflow Preventer (1/4" - 3")

Specifications:

A reduced pressure zone backflow preventer shall be installed at each potential health hazard location to prevent backflow due to backsiphonage and/or backpressure. The assembly shall consist of an internal pressure differential relief valve located in a zone between two positive seating check modules with captured springs and silicone seat discs. Seats and seat discs shall be replaceable in both check modules and the relief valve. There shall be no threads or screws in the waterway exposed to line fluids. Service of all internal components shall be through a single access cover secured with stainless steel bolts. The assembly shall also include two resilient seated isolation valves, four resilient seated test cocks and an air gap drain fitting. The assembly shall meet the requirements of: USC Manual 8th Edition; ASSE Standard. 1013; AWWA Standard. C511; CSA B64.4. The valve shall be a Watts Regulator Company Series 009.

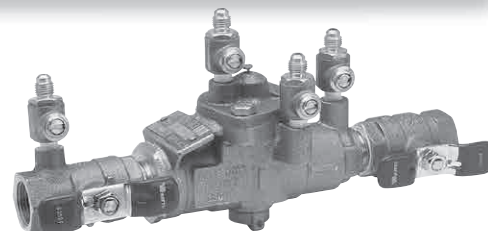

Watts Series 009

Applicable Watts Product for UPC Code Section 603.4.5:

WATTS SERIES 288A

Hot or Cold Water Anti-Siphon Vacuum Breaker (1/4" - 3")

Specifications:

An atmospheric-type anti-siphon vacuum breaker shall be installed where indicated on the plans to prevent the back-siphonage of contaminated water. This device is not to be used under continuous pressure or where there is a possibility that a back-pressure condition may develop. The device shall meet the requirements of ASSE Standard 1001, ANSI A112.1.1 and CSA B64, and shall be a Watts Regulator Company Series 288A.



Watts Series 288A

Applicable Watts Product for UPC Code Section 603.4.5:

WATTS SERIES 800M4FR

Freeze-Resistant Pressure Vacuum Breaker (1/2" - 2")

Specifications:

An anti-siphon pressure vacuum breaker shall be installed where indicated on the plans to prevent the back-siphonage of contaminated water. This assembly is not to be used where there is a possibility that a back pressure condition may develop. The assembly will incorporate an acetal bonnet with silicone rubber O-ring seal and silicone rubber seat disc. The valve shall have replaceable seats. Check assembly shall be guided over its full stroke by 'V' notch guides. The assembly shall include an internal, built-in relief valve designed to protect the internal components and the backflow body from freezing. The relief valve action shall be repeatable, automatically re-seating when the pressure within the valve is below the set point of the freeze relief valve. The assembly shall meet the requirements of ANSI/ASSE Standard 1020. The valve shall be a Watts Regulator Company Series 800M4FR.



Watts Series 800M4FR

UPC 2000 Section 603.4.6 Protection from Lawn Sprinklers and Irrigation Systems

603.4.6.1 Potable water supplies to systems having no pumps or connections for pumping equipment, and no chemical injection or provisions for chemical injection, shall be protected from backflow by one of the following devices:

1. Atmospheric vacuum breaker
2. Pressure vacuum breaker
3. Reduced pressure backflow preventer

603.4.6.2 Where sprinkler and irrigation systems have pumps, connections for pumping equipment, auxiliary air tanks or are otherwise capable of creating back-pressure, the potable water supply shall be protected by the following type of device if the backflow device is located upstream from the source of back-pressure.

1. Reduced pressure backflow preventer

603.4.6.3 Where systems have a backflow device installed downstream from a potable water supply pump or a potable water supply pump connection, the device shall be one of the following:

1. Atmospheric vacuum breaker
2. Pressure vacuum breaker
3. Reduced pressure backflow preventer

603.4.6.4 Where systems include a chemical injector or any provisions for chemical injection, the potable water supply shall be protected by the following:

1. Reduced pressure backflow preventer

Applicable Watts Product for UPC Code Section 603.4.6.1 and 603.4.6.3:

WATTS SERIES 800M4FR

Freeze-Resistant Pressure Vacuum Breaker (1/2" - 2")

Specifications:

An anti-siphon pressure vacuum breaker shall be installed where indicated on the plans to prevent the back-siphonage of contaminated water. This assembly is not to be used where there is a possibility that a back pressure condition may develop. The assembly will incorporate an acetal bonnet with silicone rubber O-ring seal and silicone rubber seat disc. The valve shall have replaceable seats. Check assembly shall be guided over its full stroke by 'V' notch guides. The assembly shall include an internal, built-in relief valve designed to protect the internal components and the backflow body from freezing. The relief valve action shall be repeatable, automatically re-seating when the pressure within the valve is below the set point of the freeze relief valve. The assembly shall meet the requirements of ANSI/ASSE Standard 1020. The valve shall be a Watts Regulator Company Series 800M4FR.



Watts Series 800M4FR

Applicable Watts Product for UPC Code Section 603.4.6.1 and 603.4.6.3:

WATTS SERIES 288A

Hot or Cold Water Anti-Siphon Vacuum Breaker (1/4" - 3")

Specifications:

An atmospheric-type anti-siphon vacuum breaker shall be installed where indicated on the plans to prevent the back-siphonage of contaminated water. This device is not to be used under continuous pressure or where there is a possibility that a back-pressure condition may develop. The device shall meet the requirements of ASSE Standard 1001, ANSI A112.1.1 and CSA B64, and shall be a Watts Regulator Company Series 288A.



Watts Series 288A

UPC 2000 Section 603.4.6 Protection from Lawn Sprinklers and Irrigation Systems - cont'd

Applicable Watts Product for UPC Code Section 603.4.6.1 and 603.4.6.3:

WATTS SERIES 008PCQT

Health Hazard Vacuum Breaker, Anti-Siphon, Spill Resistant ($3/8"$ - $1"$)

Specifications:

A spill-resistant vacuum breaker (SVB) shall be installed in accordance with the manufacturer's instructions, as noted on the plans. The valve shall consist of a one-piece modular check and float assembly made of engineered thermoplastic and housed in a bronze body. Springs shall be stainless steel. The valve shall be constructed with a molded diaphragm separating the air inlet from the potable water supply to prevent spillage. The valve shall be a Watts Regulator Company Series 008PCQT.



Watts Series 008PCQT

Applicable Watts Product for UPC Code Section 603.4.6.1, 603.4.6.2, 603.4.6.3 and 603.4.6.4:

WATTS SERIES 909

Reduced Pressure Zone Backflow Preventer ($3/4"$ - $2"$)

Specifications:

A reduced pressure zone backflow preventer shall be installed at each cross connection to prevent backsiphonage and back-pressure backflow of hazardous materials into the potable water supply. The assembly shall consist of a pressure differential relief valve located in a zone between two positive seating check valves. Back-siphonage protection shall include provision to admit air directly into the reduced pressure zone via a separate channel from the water discharge channel, or directly into the supply pipe via a separate vent. The assembly shall include two resilient seated shutoff valves before and after the assembly, test cocks and a protective strainer upstream of the No. 1 shutoff valve. The assembly (specify Model 909 for temperatures up to 140°F (60°C) or Model 909HW for temperatures up to 210°F (99°C)) shall meet the requirements of ASSE Standard 1013; AWWA Standard C-511-92 CSA B64.4; FCCCHR of USC Manual Section 10. Listed by IAPMO (UPC). SBCCI (Standard Plumbing code). The valve shall be a Watts Regulator Company Series 909QT or 909QTHW.

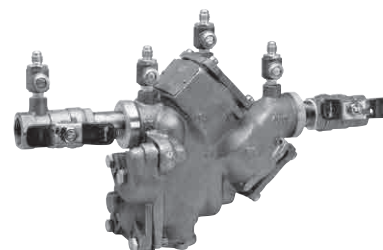

Watts Series 909

Applicable Watts Product for UPC Code Section 603.4.6.1, 603.4.6.2, 603.4.6.3 and 603.4.6.4:

WATTS SERIES 009

Reduced Pressure Zone Backflow Preventer ($1/4"$ - $3"$)

Specifications:

A reduced pressure zone backflow preventer shall be installed at each potential health hazard location to prevent backflow due to backsiphonage and/or backpressure. The assembly shall consist of an internal pressure differential relief valve located in a zone between two positive seating check modules with captured springs and silicone seat discs. Seats and seat discs shall be replaceable in both check modules and the relief valve. There shall be no threads or screws in the waterway exposed to line fluids. Service of all internal components shall be through a single access cover secured with stainless steel bolts. The assembly shall also include two resilient seated isolation valves, four resilient seated test cocks and an air gap drain fitting. The assembly shall meet the requirements of: USC Manual 8th Edition; ASSE Standard 1013; AWWA Standard C511; CSA B64.4. The valve shall be a Watts Regulator Company Series 009.



Watts Series 009

UPC 2000 Section 603.4.7 Potable Water Outlets with Hose Attachments

603.4.7 Potable Water Outlets with Hose Attachments, other than water heater drains, boiler drains, and clothes washer connections, shall be protected by a listed non-removable hose bibb type backflow preventer, a listed non-removable hose bibb type vacuum breaker or by a listed atmospheric vacuum breaker installed at least six (6) inches (152 mm) above the highest point of usage located on the discharge side of the last valve. In climates where freezing temperatures occur, a listed self-draining frost proof hose bibb with an integral backflow preventer or vacuum breaker shall be used.

Applicable Watts Product for UPC Code Section 603.4.7:

WATTS SERIES 8

Hose Connection Vacuum Breakers

Specifications:

A hose connection type anti-siphon vacuum breaker shall be installed where indicated on the plans to prevent the back-siphonage of contaminated water. This device is not to be used under continuous pressure or where there is a possibility that a back pressure condition may develop. This device shall meet the requirements of ANSI A112.1.3, ASSE Standard 1011. The valve shall be a Watts Regulator Company Series 8.



Watts Series 8

Applicable Watts Product for UPC Code Section 603.4.7:

WATTS SERIES FHB

Specifications:

A frost proof hydrant with vacuum breaker shall be installed where indicated on the plan on all outdoor hydrants or other hydrants where there is a possibility that freezing may exist. Hydrant shall be designed to be self draining even when a hose with shut off nozzle is attached. Frost proof hydrants shall be designed to meet ASSE Standard 1019. Frost proof hydrant shall be a Watts Regulator Company Series FHB.



Watts Series FHB

Applicable Watts Product for UPC Code Section 603.4.7:

WATTS SERIES 288A

Hot or Cold Water Anti-Siphon Vacuum Breaker (1/4" - 3")

Specifications:

An atmospheric-type anti-siphon vacuum breaker shall be installed where indicated on the plans to prevent the back-siphonage of contaminated water. This device is not to be used under continuous pressure or where there is a possibility that a back-pressure condition may develop. The device shall meet the requirements of ASSE Standard 1001, ANSI A112.1.1 and CSA B64, and shall be a Watts Regulator Company Series 288A.



Watts Series 288A

UPC 2000 Section 603.4.9 Water Cooled Compressors, Degreasers Section 603.4.10 Water Inlets to Water Supplied Aspirators

603.4.9 Water Cooled Compressors, Degreasers or any other water cooled equipment shall be protected by a listed backflow preventer installed in accordance with the requirements of this chapter.

Note: Water cooled equipment which produces back-pressure shall be equipped with the appropriate protection.

603.4.10 Water Inlets to Water Supplied Aspirators shall be equipped with a listed vacuum breaker installed in accordance with its listing requirements and this chapter. The discharge shall drain through an airgap. When using the tailpiece of a fixture to receive the discharge of an aspirator, the airgap shall be located above the flood rim of the fixture.

Applicable Watts Product for UPC Code Section 603.4.9:

WATTS SERIES 009

Reduced Pressure Zone Backflow Preventer (1/4" - 3")

Specifications:

A reduced pressure zone backflow preventer shall be installed at each potential health hazard location to prevent backflow due to backsiphonage and/or back-pressure. The assembly shall consist of an internal pressure differential relief valve located in a zone between two positive seating check modules with captured springs and silicone seat discs. Seats and seat discs shall be replaceable in both check modules and the relief valve. There shall be no threads or screws in the waterway exposed to line fluids. Service of all internal components shall be through a single access cover secured with stainless steel bolts. The assembly shall also include two resilient seated isolation valves, four resilient seated test cocks and an air gap drain fitting. The assembly shall meet the requirements of: USC Manual 8th Edition; ASSE Standard 1013; AWWA Standard C511; CSA B64.4. The valve shall be a Watts Regulator Company Series 009.

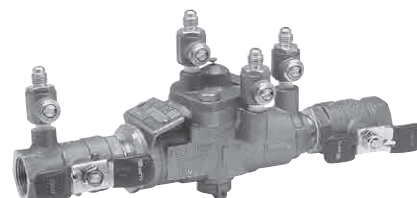

Watts Series 009

Applicable Watts Product for UPC Code Section 603.4.10:

WATTS SERIES 008PCQT

Health Hazard Vacuum Breaker, Anti-Siphon, Spill Resistant (3/8" - 1")

Specifications:

A spill-resistant vacuum breaker (SVB) shall be installed in accordance with the manufacturer's instructions, as noted on the plans. The valve shall consist of a one-piece modular check and float assembly made of engineered thermoplastic and housed in a bronze body. Springs shall be stainless steel. The valve shall be constructed with a molded diaphragm separating the air inlet from the potable water supply to prevent spillage. The valve shall be a Watts Regulator Company Series 008PCQT.



Watts Series 008PCQT

UPC 2000 Section 603.4.11 Potable Water Make Up Connections to Steam or Hot Water Boilers

603.4.11 Potable Water Make Up Connections to Steam or Hot Water Boilers shall be provided with a listed backflow protection assembly.

Applicable Watts Product for UPC Code Section 603.4.11:

WATTS SERIES 9D

Backflow Preventer with Intermediate Atmospheric Vent (1/2" - 3/4")

Specifications:

Important: Inquire with governing authorities for local installation requirements. A Dual Check with Atmospheric Vent shall be installed at referenced cross-connections. Valve shall feature stainless steel and rubber internals protected by an integral strainer. Primary check shall be rubber to rubber seated, backed by the secondary check with rubber to metal seating. The device shall be ASSE approved under Standard. 1012 and shall be a Watts Regulator Company Series 9D.



Watts Series 9D

Applicable Watts Product for UPC Code Section 603.4.11:

WATTS SERIES 909

Reduced Pressure Zone Backflow Preventer (3/4" - 2")

Specifications:

A reduced pressure zone backflow preventer shall be installed at each cross connection to prevent backsiphonage and back-pressure backflow of hazardous materials

into the potable water supply. The assembly shall consist of a pressure differential relief valve located in a zone between two positive seating check valves. Back-siphonage protection shall include provision to admit air directly into the reduced pressure zone via a separate channel from the water discharge channel, or directly into the supply pipe via a separate vent. The assembly shall include two resilient seated shutoff valves before and after the assembly, test cocks and a protective strainer upstream of the No. 1 shutoff valve. The assembly (specify Model 909 for temperatures up to 140°F (60°C) or Model 909HW for temperatures up to 210°F (99°C)) shall meet the requirements of ASSE Standard 1013; AWWA Standard C-511-92 CSA B64.4; FCCCHR of USC Manual Section 10. Listed by IAPMO (UPC). SBCCI (Standard Plumbing code). The valve shall be a Watts Regulator Company Series 909QT or 909QTHW.

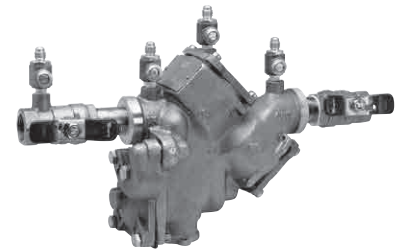

Watts Series 909

Applicable Watts Product for UPC Code Section 603.4.11:

WATTS SERIES 009

Reduced Pressure Zone Backflow Preventer (1/4" - 3")

Specifications:

A reduced pressure zone backflow preventer shall be installed at each potential health hazard location to prevent backflow due to backsiphonage and/or back-pressure. The assembly shall consist of an internal pressure differential relief valve located in a zone between

two positive seating check modules with captured springs and silicone seat discs. Seats and seat discs shall be replaceable in both check modules and the relief valve. There shall be no threads or screws in the waterway exposed to line fluids. Service of all internal components shall be through a single access cover secured with stainless steel bolts. The assembly shall also include two resilient seated isolation valves, four resilient seated test cocks and an air gap drain fitting. The assembly shall meet the requirements of: USC Manual 8th Edition; ASSE Standard 1013; AWWA Standard C511; CSA B64.4. The valve shall be a Watts Regulator Company Series 009.



Watts Series 009

UPC 2000 CODE - CHAPTER 6 - WATER SUPPLY AND DISTRIBUTION

UPC 2000 Section 603.4.13 Potable Water Supply to Carbonators 603.4.16 Deck-Mounted or Equipment-Mounted Vacuum Breakers

603.4.13 Potable Water Supply to Carbonators shall be protected by either an airgap or a vented backflow preventer for carbonated beverage dispensers installed within the carbonated beverage dispenser. The carbonated beverage dispenser shall bear the label of an approved testing agency, certifying and attesting that such equipment has been tested and inspected, and meets the requirements of the approved applicable standard. Carbonated beverage dispensers without an approved internal airgap or vented backflow preventer for carbonated beverage dispensers and carbonated beverage dispensing systems shall have the water supply protected with a vented backflow preventer for carbonated beverage dispensers.

603.4.16 Deck-Mounted or Equipment-Mounted Vacuum Breakers shall be installed in accordance with their listing and the manufacturer's instructions, with the critical level not less than one (1) inch (25.4 mm) above the flood level rim.

Applicable Watts Product for UPC Code Section 603.4.13:

WATTS SERIES SD-3

Backflow Preventer for Carbonated Beverage Machines (1/2", 3/8")

Specifications:

Backflow preventer body and adapters shall be 316 stainless steel construction and all rubber components shall comply with FDA food additive regulations. All materials in contact with the potable water shall be in compliance with the requirements of the Safe Drinking Water Act, Public Law 93-523, National Interim Primary Drinking Water Regulations. Strainer shall be manufactured from NSF approved acetal plastic. The valve shall be a Watts Regulator Company Series SD-3.



Watts Series SD-3

Applicable Watts Product for UPC Code Section 603.4.16:

WATTS SERIES 008PCQT

Health Hazard Vacuum Breaker, Anti-Siphon, Spill Resistant (3/8" - 1")

Specifications:

A spill-resistant vacuum breaker (SVB) shall be installed in accordance with the manufacturer's instructions, as noted on the plans. The valve shall consist of a one-piece modular check and float assembly made of engineered thermoplastic and housed in a bronze body. Springs shall be stainless steel. The valve shall be constructed with a molded diaphragm separating the air inlet from the potable water supply to prevent spillage. The valve shall be a Watts Regulator Company Series 008PCQT.



Watts Series 008PCQT

Applicable Watts Product for UPC Code Section 603.4.16:

WATTS SERIES N388

Specifications:

An atmospheric type anti-siphon vacuum breaker shall be installed where indicated on the plans to prevent the backsiphonage of contaminated water. The device shall include lightweight disc float with silicone disc for tight seating. This device is not to be used under continuous pressure or where there is a possibility that a back pressure condition may develop. The device shall meet the requirement of ASSE Standard 1001: CSA B64.1.1. The valve shall be a Watts Regulator Company Series N388.



Watts Series N388

UPC 2000 Section 603.4.18 Protection from Fire Systems

603.4.18.1 Except as provided under Sections 603.4.18.2 and 603.4.18.3, potable water supplies to fire protection systems that are normally under pressure, including but not limited to standpipes and automatic sprinkler systems, except in one or two family residential sprinkler systems piped in materials approved for potable water distribution systems, shall be protected from back-pressure and back-siphonage by one of the following devices:

1. Double check valve assembly
2. Double check detector assembly
3. Reduced pressure backflow preventer
4. Reduced pressure detector assembly

Potable water supplies to fire protection systems that are not normally under pressure shall be protected from backflow and shall meet the requirements of the appropriate standard(s) Referenced in Table 14-1.

603.4.18.2 Where fire protection systems supplied from a potable water system include a fire department (Siamese) connection which is located less than seventeen hundred (1700) feet (518.2m) from a non-potable water source that could be used by the fire department as a secondary water supply, the potable water supply be protected by one of the following:

1. Reduced pressure backflow preventer
2. Reduced pressure detector assembly

Note: Non-potable water sources include fire department vehicles carrying water of questionable quality or water that is treated with antifreeze, corrosion inhibitors, or extinguishing agents.

603.4.18.3 Where antifreeze, corrosion inhibitors, or other chemicals are added to a fire protection system supplied from a potable water supply, the potable water system shall be protected by one of the following:

1. Reduced pressure backflow preventer
2. Reduced pressure detector assembly

603.4.18.4 Whenever a backflow device is installed in the potable water supply to a fire protection system, the hydraulic design of the system shall account for the pressure drop through the backflow device. If such devices are retrofitted for an existing fire protection system, the hydraulics of the sprinkler system design shall be checked to verify that there will be sufficient water pressure available for satisfactory operation of the fire sprinklers.

Applicable Watts Product for UPC Code Section 603.4.18.1:

WATTS SERIES 007

Double Check Valve Assembly (1/2" - 3")

Specifications:

A double check valve backflow preventer shall be installed at each noted location. The assembly shall consist of two positive seating check modules with captured springs and rubber seat discs. The check module seats and seat discs shall be replaceable. Service of all internal components shall be through a single access cover secured with stainless steel bolts. The assembly shall also include two resilient seated isolation valves; four top mounted, resilient seated test cocks. The assembly shall meet the requirements of ASSE Standard 1015 and AWWA Standard C510. Approved by the Foundation for Cross-Connection Control and Hydraulic Research at the University of Southern California. The valve shall be a Watts Regulator Company Series 007.



Watts Series 007

UPC 2000 Section 603.4.18 Protection from Fire Systems - cont'd

Applicable Watts Product for UPC Code Section 603.4.18.1:

WATTS SERIES 007DCDA

Double Check Detector Assembly (2"-3")

Specifications:

A double check detector assembly backflow preventer shall be installed on fire protection systems when connected to a potable water supply. Degree of hazard present is determined by the local authority having jurisdiction. The backflow preventer shall be a complete assembly including UL listed resilient seated OS&Y shutoff valves and four test cocks. The test cocks located on the backflow preventer shall be mounted at the top of the valve to reduce clearance problems and to assist in the evacuation of air from the assembly. The assembly shall consist of two independently operating modular poppet-type check valves. The check valves shall utilize captured springs and shall have replaceable seats. The checks shall be double-guided, both along the outside edge of the check module and through the center stem assembly. The seats shall be replaceable without the use of special tools. Seat retention shall be done by the use of an interlocking bayonet style cage and the use of threaded seats or seat screws is prohibited. Access to the internal check assemblies shall be via a single top entry cover. The cover shall be securely held in place by stainless steel bolts. Where applicable the unit shall be FM approved with FM approved OS&Y resilient seated shutoff valves. The assembly shall include an auxiliary bypass line consisting of an approved backflow preventer and water meter. The assembly shall be listed or approved under the requirements of ASSE Standard. 1048, AWWA Standard. C510-92 and CSA B64.5. Approved by the Foundation for Cross-Connection Control and Hydraulic Research at the University of Southern California. The assembly shall be a Watts Regulator Company Series 007DCDA.

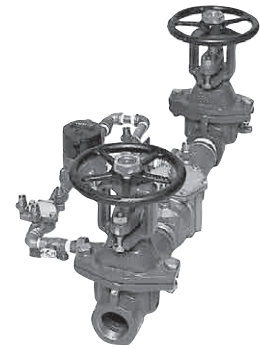

Watts Series 007DCDA

Applicable Watts Product for UPC Code Section 603.4.18.1:

WATTS SERIES 709

Double Check Valve Backflow Preventer (2 1/2" - 10")

Specifications:

A double check valve backflow preventer shall be installed at referenced cross-connections to prevent the backflow of polluted water into the potable water supply. The cross-connections shall be determined by local inspection authority for use where a high hazard situation does not exist. Valve shall feature modular check assemblies with center stem guiding. Each check module shall have a captured spring and be accessible through a bolted cover plate. Seats shall be replaceable without special tools. It shall be a complete assembly including tight-closing resilient seated shutoff valves, test cocks, and a strainer is recommended. The assembly shall meet the requirements of ASSE No. 1015; AWWA C510-92; CSA B64.5 and UL Classified File No. EX3185. Approved by the Foundation for Cross-Connection Control and Hydraulic Research at the University of Southern California. The valve shall be a Watts Regulator Company Series 709.



Watts Series 709

Applicable Watts Product for UPC Code Section 603.4.18.1:

WATTS SERIES 709DCDA

Double Check Detector Assembly Backflow Preventer (3", 4", 6", 8", 10")

Specifications:

A double check detector assembly backflow preventer shall be installed on fire protection systems when connected to a potable water supply. Degree of hazard present is determined by the local authority having jurisdiction. The unit shall be a complete assembly including UL listed resilient seated OS&Y shutoff valves and test cocks. The unit shall be UL/FM approved with UL/FM approved OS&Y shutoff valves. The auxiliary line shall consist of an approved backflow preventer and water meter. The assembly shall meet the basic requirements of ASSE 1048; AWWA Standard C510 for Double Check Valves. Approved by the Foundation for Cross-Connection Control and Hydraulic Research at the University of Southern California. The valve shall be a Watts Regulator Company Series 709DCDA OSY.

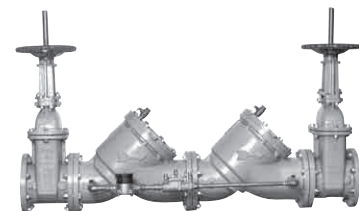

Watts Series 709DCDA

UPC 2000 Section 603.4.18 Protection from Fire Systems - cont'd

Applicable Watts Product for UPC Code Section 603.4.18.1, 603.4.18.2 and 603.4.18.3:

WATTS SERIES 995RPDA

Reduced Pressure Detector Assembly (3"-6")

Specifications:

A reduced pressure zone assembly backflow preventer shall be installed at each noted location to prevent the unwanted reversal of hazardous water into the potable water supply. The main valve shall be manufactured from 300 Series stainless steel to provide corrosion resistance and eliminate corrosion due to pitting of epoxy coated valves. The check valves shall be of thermo-plastic construction with stainless steel hinge pins, cam bearing, and center pivot arm. The check valves shall have reversible check disc rubber and use a single torsion spring design to minimize pressure drop through the assembly. The check valves shall be modular and shall be threaded into the main valve body to insure a positive seal. There shall be no brass or bronze parts used within the check valve assembly. The valve cover shall be held in place through the use of a single grooved style two-bolt coupling and gasket / diaphragm. The use of special gaskets/O-rings to seal the cover and body interface is not allowed. The relief valve shall use a dual purpose cover gasket and relief valve diaphragm to separate inlet pressure from zone pressure. The relief valve shall include a bulk-head-mounted seat to insure that the relief valve seat threads are not exposed to line fluid. The main assembly shall consist of two independently operating torsion spring check assemblies, two resilient seated isolation valves, an in-line style relief valve, a hydraulically balanced bypass line and four ball valve type test cocks. The backflow prevention assembly shall be a Watts Regulator Company Series 995RPDA.

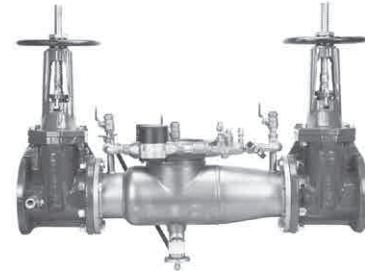

Watts Series 995RPDA

Applicable Watts Product for UPC Code Section 603.4.18.1, 603.4.18.2 and 603.4.18.3:

WATTS SERIES 909

Reduced Pressure Zone Backflow Preventer (3/4" - 2")

Specifications:

A reduced pressure zone backflow preventer shall be installed at each cross connection to prevent backsiphonage and back-pressure backflow of hazardous materials into the potable water supply. The assembly shall consist of a pressure differential relief valve located in a zone between two positive seating check valves. Back-siphonage protection shall include provision to admit air directly into the reduced pressure zone via a separate channel from the water discharge channel, or directly into the supply pipe via a separate vent. The assembly shall include two resilient seated shutoff valves before and after the assembly, test cocks and a protective strainer upstream of the No. 1 shutoff valve. The assembly (specify Model 909 for temperatures up to 140°F (60°C) or Model 909HW for temperatures up to 210°F (99°C)) shall meet the requirements of ASSE Standard 1013; AWWA Standard C-511-92 CSA B64.4; FCCCHR of USC Manual Section 10. Listed by IAPMO (UPC). SBCCI (Standard Plumbing code). The valve shall be a Watts Regulator Company Series 909QT or 909QTHW.

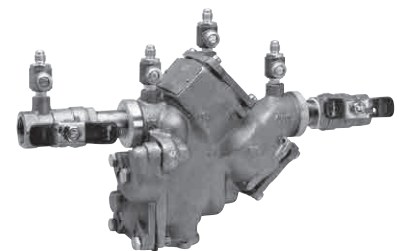

UPC 2000 CODE - CHAPTER 6 - WATER SUPPLY AND DISTRIBUTION

UPC 2000 Section 603.4.18 Protection from Fire Systems - cont'd

Other Applicable Watts Products for UPC Code Section 603.4.18.1, 603.4.18.2 and 603.4.18.3

Valve Type	Model	Sizes (in.)	Applicable Standards
Double Check Detector Assemblies	774DCDA	4 - 12	ASSE Std.1048
	774XDCDA	6 - 8	ASSE Std. 1048
	775DCDA	3 - 8	ASSE Std. 1048
Double Check Valve Assemblies	774OSY	4 - 12	ASSE Std. 1015, AWWA C510-97
	774XOSY	6 - 8	ASSE Std. 1015, AWWA C510-97
	775OSY	3 - 8	ASSE Std. 1015, AWWA C510-97, IAMPO PS31
Reduced Pressure Zone Backflow Preventers	909OSY	2 ¹ / ₂ - 10	ASSE Std. 1013, AWWA C511-97, CSA B64.4, IAMPO PS31
	994OSY	2 ¹ / ₂ - 10	ASSE Std. 1013, AWWA C511-97, IAMPO PS31
	995OSY	3 - 6	ASSE Std. 1013, AWWA C511-97, IAMPO PS31
Reduced Pressure Detector Assemblies	909RPDA	2 ¹ / ₂ - 10	CSA B64.4
	994RPDA	4 - 6	ASSE Std. 1047, AWWA C511-92, CSA B64.5
	995RPDA	3 - 6	ASSE Std. 1047, CSA B64.4

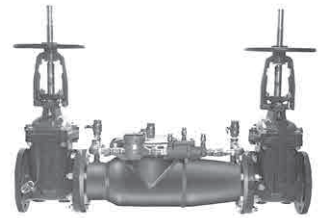

Watts Series 774DCDA

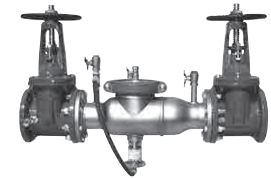

Watts Series 994OSY

UPC 2000 Section 603.4.18 Protection from Fire Systems - cont'd

603.4.18.5 Residential Sprinkler Systems. When residential sprinkler systems are installed using the potable water system they shall be installed in accordance with the standards listed in Table 14-1.

Applicable Watts Product for UPC Code Section 603.4.18.5:

WATTS SERIES 007

Double Check Valve Assembly (1/2" - 3")

Specifications:

A double check valve backflow preventer shall be installed at each noted location. The assembly shall consist of two positive seating check modules with captured springs and rubber seat discs. The check module seats and seat discs shall be replaceable. Service of all internal components shall be through a single access cover secured with stainless steel bolts. The assembly shall also include two resilient seated isolation valves; four top mounted, resilient seated test cocks. The assembly shall meet the requirements of ASSE Standard 1015 and AWWA Standard C510. Approved by the Foundation for Cross-Connection Control and Hydraulic Research at the University of Southern California. The valve shall be a Watts Regulator Company Series 007.



Watts Series 007

UPC 2000 CODE - CHAPTER 6 - WATER SUPPLY AND DISTRIBUTION

UPC 2000 Section 603.4.18 Protection from Fire Systems - cont'd

603.4.18.5 Residential Sprinkler Systems - cont'd

Applicable Watts Product for UPC Code Section 603.4.18.5:

WATTS SERIES 009

Reduced Pressure Zone Backflow Preventer (1/4" – 3")

Specifications:

A reduced pressure zone backflow preventer shall be installed at each potential health hazard location to prevent backflow due to backsiphonage and/or back-pressure. The assembly shall consist of an internal pressure differential relief valve located in a zone between two positive seating check modules with captured springs and silicone seat discs. Seats and seat discs shall be replaceable in both check modules and the relief valve. There shall be no threads or screws in the waterway exposed to line fluids. Service of all internal components shall be through a single access cover secured with stainless steel bolts. The assembly shall also include two resilient seated isolation valves, four resilient seated test cocks and an air gap drain fitting. The assembly shall meet the requirements of: USC Manual 8th Edition; ASSE Standard 1013; AWWA Standard C511; CSA B64.4. The valve shall be a Watts Regulator Company Series 009.

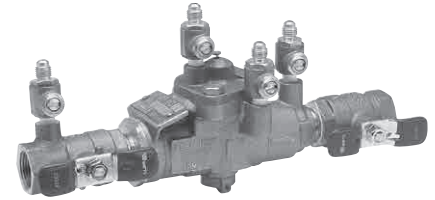

Watts Series 009

UPC 2000 Section 603.4.19 Special Equipment, Water Supply Protection 603.4.20 Portable Cleaning Equipment, Dental Vacuum Pumps

603.4.19 Special Equipment, Water Supply Protection. Vacuum breakers for washer-hose bedpans shall be located not less than five (5) feet (1524 mm) above the floor. Hose connections in health care or laboratory areas shall not be less than six (6) feet (1829 mm) above the floor.

603.4.20 Portable Cleaning Equipment, Dental Vacuum Pumps and chemical dispensers shall be protected from backflow by an airgap, an atmospheric vacuum breaker, a spill-proof vacuum breaker, or a reduced pressure principle backflow preventer.

Applicable Watts Product for UPC Code Section 603.4.19 and 603.4.20:

WATTS SERIES 009

Reduced Pressure Zone Backflow Preventer (1/4" – 3")

Specifications:

A reduced pressure zone backflow preventer shall be installed at each potential health hazard location to prevent backflow due to backsiphonage and/or back-pressure. The assembly shall consist of an internal pressure differential relief valve located in a zone between two positive seating check modules with captured springs and silicone seat discs. Seats and seat discs shall be replaceable in both check modules and the relief valve. There shall be no threads or screws in the waterway exposed to line fluids. Service of all internal components shall be through a single access cover secured with stainless steel bolts. The assembly shall also include two resilient seated isolation valves, four resilient seated test cocks and an air gap drain fitting. The assembly shall meet the requirements of: USC Manual 8th Edition; ASSE Standard 1013; AWWA Standard C511; CSA B64.4. The valve shall be a Watts Regulator Company Series 009.



Watts Series 009

UPC 2000 CODE - CHAPTER 6 - WATER SUPPLY AND DISTRIBUTION

UPC 2000 Section 603.4.19 Special Equipment, Water Supply Protection 603.4.20 Portable Cleaning Equipment, Dental Vacuum Pumps Vacuum Pumps

603.4.19 Special Equipment, Water Supply Protection - cont'd

603.4.20 Portable Cleaning Equipment, Dental Vacuum Pumps - cont'd

Applicable Watts Product for UPC Code Section 603.4.19 and 603.4.20:

WATTS SERIES 288A

Hot or Cold Water Anti-Siphon Vacuum Breaker (1/4" - 3")

Specifications:

An atmospheric-type anti-siphon vacuum breaker shall be installed where indicated on the plans to prevent the back-siphonage of contaminated water. This device is not to be used under continuous pressure or where there is a possibility that a back-pressure condition may develop. The device shall meet the requirements of ASSE Standard 1001, ANSI A112.1.1 and CSA B64, and shall be a Watts Regulator Company Series 288A.



Watts Series 288A

Applicable Watts Product for UPC Code Section 603.4.19 and 603.4.20:

WATTS SERIES 008PCQT

Health Hazard Vacuum Breaker, Anti-Siphon, Spill Resistant (3/8" - 1")

Specifications:

A spill-resistant vacuum breaker (SVB) shall be installed in accordance with the manufacturer's instructions, as noted on the plans. The valve shall consist of a one-piece modular check and float assembly made of engineered thermoplastic and housed in a bronze body. Springs shall be stainless steel. The valve shall be constructed with a molded diaphragm separating the air inlet from the potable water supply to prevent spillage. The valve shall be a Watts Regulator Company Series 008PCQT.



Watts Series 008PCQT

UPC 2000 Section 603.4.21 Water Heater Connectors

603.4.21 Water Heater Connectors. Flexible metallic water heater connectors or reinforced flexible water heater connectors connecting water heaters to the piping system shall be in compliance with the appropriate standards listed in Table 14-1.

Applicable Watts Product for UPC Code Section 603.4.21:

WATTS SERIES CWH-S

Braided Stainless Steel Water Heater Connectors

Specifications:

Water heater connectors should be installed in accordance with manufacturer's instructions, as noted on the plans. The connectors shall consist on PVC tubing jacketed with braided stainless steel and end fittings which are permanently attached with multi-crimp process. Connectors shall be Watts Regulator Company Series CWH-S.

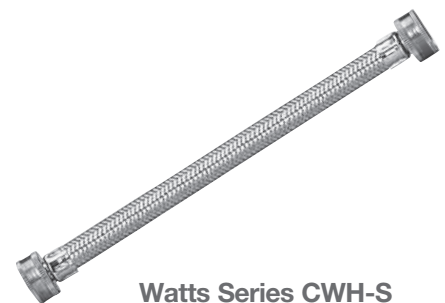

Watts Series CWH-S

UPC 2000 Code - CHAPTER 6 - WATER SUPPLY AND DISTRIBUTION

UPC 2000 Section 605 Valves

605.1 Valves up to and including two (2) inches (51mm) in size shall be brass or other approved material. Sizes over two (2) inches (51 mm) may have cast iron or brass bodies. Each gate or ball valve shall be a fullway type with working parts of non-corrosive material.

605.2 A fullway valve controlling all outlets shall be installed on the discharge side of each water meter and on each unmetered water supply. Water piping supplying more than one building on any one premises shall be equipped with a separate fullway valve to each building, so arranged that the water supply can be turned on or off to any individual or separate building; provided however, that supply piping to a single family residence and building accessory thereto, may be controlled on one valve. Such shutoff valves shall be accessible at all times. A fullway valve shall be installed on the discharge piping from water supply tanks at or near the tank. A fullway valve shall be installed on the cold water supply pipe to each water heater at or near the water heater.

605.3 In multi-dwelling units, one (1) or more shutoff valves shall be provided in each dwelling unit so that the water supply to any plumbing fixture or group of fixtures in that dwelling unit can be shut off without stopping water supply to fixtures in other dwelling units. These valves shall be accessible in the dwelling unit that they control.

605.4 All valves used to control two (2) or more openings shall be fullway gate valves, ball valves or other approved valves designed and approved for the service intended.

605.5 A control valve shall be installed immediately ahead of each water supplied appliance and immediately ahead of each slip joint or non-metallic fixture supply or appliance supply.

605.7 A single control valve shall be installed on a water supply line ahead of any automatic metering valve which supplied a battery of fixtures.

Applicable Watts Product for UPC Code Section 605.1, 605.2, 605.3, 605.4, 605.5 and 605.7:

WATTS SERIES FBV-3

2 Piece, Full Port Brass Ball Valves (1/4" - 3")

Specifications:

Approved valves shall have bottom loaded, pressure retaining stems, virgin PTFE seats, and full port. Ball shall be chrome plated brass with brass stem. Valves shall be pressure rated at 600 psi WOG (non-shock), 125psi saturated steam. Each valve shall be tested in the opened and closed position by the manufacturer. Valve must conform to MSS-SP-110. The valve shall be a Watts Regulator Company Series FBV-3 (threaded NPT) or FBVS-3 (solder).



Watts Series FBV-3

Applicable Watts Product for UPC Code Section 605.1, 605.2, 605.3, 605.4, 605.5 and 605.7:

WATTS SERIES B-6080

2 Piece, Full Port Bronze Ball Valves (1/2" - 2")

Specifications:

Valves shall be 2-piece, full port construction, bronze ASTM B-584 body, electroless nickel plated ASTM B-16 or B-124 brass ball, blow-out proof ASTM B-16 brass stem, Virgin PTFE seats, PTFE stem packing and stem thrust bearing. Valves shall be pressure rated to 150psi (8.6 bars) WSP, 600psi (28 bars) WOG, and either threaded NPT or solder end connections. Valves shall be manufactured to the MSS-SP-110 standard. The valve shall be a Watts Regulator Company B-6080 (threaded) or B-6081 (solder) end.



Watts Series B-6080

Applicable Watts Product for UPC Code Section 605.1, 605.2, 605.3, 605.4, 605.5 and 605.7:

WATTS SERIES B-6800

3 Piece, Full Port Brass Ball Valves (1/4" - 2")

Specifications:

Valves shall be 3-piece, full port, in-line maintenance type, constructed of ASTM B-124 brass body, brass ASTM B-16, or B-124 electroless nickel-plated ball, reinforced Durafill seats, reinforced PTFE stem packing and stem thrust bearing, ASTM B-16 brass blow-out proof stem. Valves shall be pressure rated to 150psi (10 bars) WSP, 600psi (41 bars) WOG 1/4" - 1" (8-25 mm), 400 psi (28 bars) WOG 1 1/4" - 2" (32-50 mm); and have either threaded NPT or solder end connections. Valves shall be manufactured to MSS-SP-110. The valve shall be a Watts Regulator Company B-6800 (threaded) or B-6801 (solder) end.



Watts Series B-6800

UPC 2000 Section 608 Water Pressure, Pressure Regulators, Pressure Relief Valves, and Vacuum Relief Valves

608.1 Inadequate Water Pressure. Whenever the water pressure in the main or other source of supply will not provide a residual water pressure of at least fifteen (15) pounds per square inch (103.4 kPa), after allowing for friction and other pressure losses, a tank and a pump or other means which will provide said fifteen (15) pound (103.4 kPa) pressure shall be installed. Whenever fixtures and/or fixture fittings are installed, which require residual pressure higher than fifteen (15) pounds per square inch (103.4 kPa), that minimum residual pressure shall be provided.

608.2 Excessive Water Pressure. Where local static water pressure is in excess of eighty (80) pounds per square inch (552 kPa), an approved type pressure regulator preceded by an adequate strainer shall be installed and the static pressure reduced to eighty (80) pounds per square inch (552 kPa) or less. For potable water services up to and including one and one-half (1-1/2) inch (40 mm) regulators, provision shall be made to prevent pressure on the building side of the regulator from exceeding main supply pressure. Approved regulators with integral bypasses shall be acceptable. Each such regulator and strainer shall be accessibly located and shall have the strainer readily accessible for cleaning without removing the regulator or strainer body or disconnecting the supply piping. All pipe size determinations shall be based on eighty (80) percent of the reduced pressure when using Table 6-5.

Applicable Watts Product for UPC Code Section 608.1:

WATTS SERIES 115-AN

Pressure Booster System

Specifications:

Pressure booster system shall have as final pressure control, Watts ACV model 115-AN pressure reducing, pressure sustaining, and check valve. Pressure sustaining control shall be piped to the suction side of the pump. The control system shall be equipped with manual ball valve shut offs to allow field repairs and maintenance in the line, opening and closing speed controls and a pilot system strainer. Main valve shall be cast iron with fused epoxy coating inside and out. When the valve is the closed position, sealing at the seat shall be accomplished by contact between one edge of a securely retained elastomer quad seal and a smooth seat surface. Seat design shall be removable and not have edges that will induce seal cutting, or wear at low flows. Main valve shaft shall be guided at top and bottom. Valves must have bubble tight shut off. Piston style valves will be unacceptable. The valve shall be a Watts Regulator Company Series 115-AN. Consult your local Watts agent for sizing and application help.

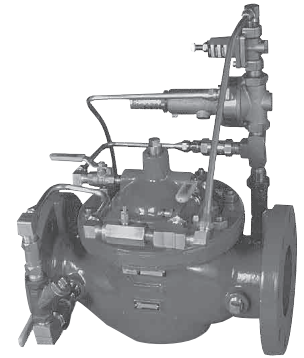

Watts Series 115-AN

Applicable Watts Product for UPC Code Section 608.2:

WATTS SERIES 223S

Super Capacity Water Pressure Regulators (1/2" - 3")

Specifications:

A pressure regulating valve shall be installed where noted to reduce supply pressures to 50psi or less. The installation shall include a strainer on the inlet side of the regulator. The regulator shall feature a removable seat disc and disc holder that can be removed in-line without special tools. The valve diaphragm shall resist hot or cold water temperature damage. The spring cage shall be sealed for below grade service. Adjusting screw and cage screws shall be corrosion resistant. Approved valves shall comply with ASSE 1003. The valve shall be a Watts Regulator Company Series 223S.

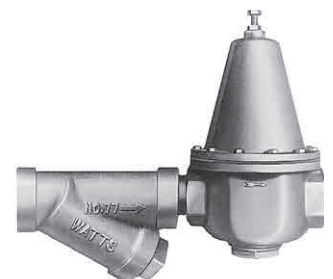

Watts Series 223S

UPC 2000 Section 608 Water Pressure, Pressure Regulators, Pressure Relief Valves, and Vacuum Relief Valves - cont'd

Applicable Watts Product for UPC Code Section 608.2:

WATTS SERIES 25AUB

Water Pressure Reducing Valves (1/2" - 2")

Specifications:

When the supply main pressure exceeds 60psi (413 kPa), an approved water pressure reducing valve and strainer shall be installed on the water service pipe near its entrance to the building to reduce the water pressure to 50psi (345 kPa) or lower. Sill cocks and outside wall hydrants may be left on full main pressure at the option of the owner. For service water systems up to and including 2" (50mm) provision shall be made to permit the bypass flow of water around the valve back into the supply main when pressures, due to thermal expansion on the outlet side of the valve, exceed the pressure in the supply main. Pressure reducing valves with built-in bypass check valves will be acceptable. Approved valves shall comply with ASSE 1003. The valve shall be a Watts Regulator Company Series 25AUB.



Watts Series 25AUB

Applicable Watts Product for UPC Code Section 608.2:

WATTS SERIES U5B

Water Pressure Reducing Valves (1/2" - 2")

Specifications:

When supply main pressure exceeds 60psi (413 kPa), an approved water pressure reducing valve and strainer shall be installed on the water service pipe near its entrance to the building to reduce the water pressure to 50psi (345 kPa) or lower. Sill cocks and outside wall hydrants may be left on full main pressure at the option of the owner. For service water systems up to and including 2" (50mm), provision shall be made to permit the bypass flow of water around the valve back into the main when pressures, due to thermal expansion on the outlet side of the valve, exceed the pressure in the main. Pressure reducing valves with built-in bypass check valves will be acceptable. Approved valves shall comply fully with ASSE Standard No. 1003. The valve shall be a Watts Regulator Company Series U5B.



Watts Series U5B

Applicable Watts Product for UPC Code Section 608.2:

WATTS SERIES 115

Water Pressure Reducing Valves (1 1/4" - 24")

Specifications:

Watts Series 115/1115 automatically reduces a higher inlet pressure to a constant lower pressure regardless of changing flow rates and/or varying inlet pressures. Body shall be ductile iron ANSI B16.1 fusion bond epoxy coated, inside and out. Diaphragm actuated by hydraulic pilot. Valves shall be appropriate for dead end service. All elastomers shall be of FDA approved materials. Seat shall be renewable 316 stainless steel. The disc shall be quad seal retained on three sides by the disc holder. Disc holder shall be configured to create a needle valve for smooth laminar flow over the seat when low flows are required. Disc/ diaphragm assembly must be top and bottom guided to assure proper disc/seat alignment. Raised sharp seats will not be accepted. Consult your local Watts agent for sizing and application help.

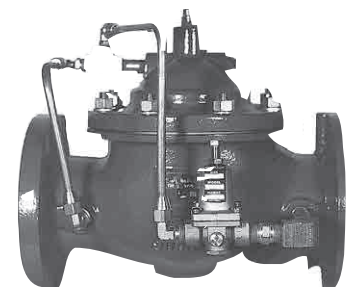

Watts Series 115

UPC 2000 Section 608 Water Pressure, Pressure Regulators, Pressure Relief Valves, and Vacuum Relief Valves - cont'd

608.3 Any water system provided with a check valve, backflow preventer or a pressure regulating device which does not have a bypass feature at its source shall be provided with an approved, listed adequately sized pressure relief valve or a means to control expansion.

Any water system containing storage water heating equipment shall be provided with an approved, listed adequately sized combination pressure and temperature relief valve, except for listed non-storage instantaneous heaters having an inside diameter of not more than three (3) inches (80 mm). Each approved combination temperature and relief valve shall be installed on the water heating device in an approved location based on its listing requirements and the manufacturer's instructions. Each such combination temperature and pressure relief valve shall be provided with a drain as required in Section 608.5.

In addition to the required pressure or combination pressure and temperature relief valve, an approved, listed expansion tank or other device designed for intermittent operation for thermal expansion control shall be installed whenever the building supply pressure is greater than the required relief valve pressure setting or when any device is installed that prevents pressure relief through the building supply. The tank or device shall be sized in accordance with the manufacturer's recommendation.

Applicable Watts Product for UPC Code Section 608.3:

WATTS SERIES ILT

In-Line Thermal Expansion Tank

Specifications:

The potable water expansion tank shall be of steel construction. It shall be of flow through design. It shall have a Butyl diaphragm separating the air chamber from the water containment chamber. Inlet and outlet connectors shall be union thread or sweat. Materials of manufacture for diaphragm shall be FDA approved. The potable water expansion tank shall be a Watts Regulator Company Series ILT.



Watts Series ILT

Applicable Watts Product for UPC Code Section 608.3:

WATTS SERIES DET

Thermal Expansion Tank

Specifications:

The potable water expansion tank shall be of drawn steel construction. It shall have a Butyl diaphragm separating the air chamber from the water containment chamber. Inlet connector shall be brass (Model DET-35: Stainless Steel). Materials of manufacture for the diaphragm shall be FDA approved. The potable water expansion tank shall be a Watts Regulator Company Series DET.



Watts Series DET

Applicable Watts Product for UPC Code Section 608.3:

WATTS SERIES PET

Thermal Expansion Tank

Specifications:

The potable water expansion tank shall be of drawn steel construction and include a thermally bonded epoxy liner in the water containing area. It shall have a Butyl diaphragm separating the air chamber from the water containment chamber. Inlet connector shall be stainless steel. Materials of manufacture for the liner and diaphragm shall be FDA approved. The potable water expansion tank shall be a Watts Regulator Company Series PET.



Watts Series PET

UPC 2000 Section 608 Water Pressure, Pressure Regulators, Pressure Relief Valves, and Vacuum Relief Valves - cont'd

608.4 Each pressure relief valve shall be an approved automatic type with drain, and each such relief valve shall be set at a pressure of not more than one hundred fifty (150) pounds per square inch (1035 kPa). No shut off valve shall be installed between the relief valve and the system or in the drain line.

608.5 Relief valves located inside a building shall be provided with a drain, not smaller than the relief valve outlet, of galvanized steel, hard drawn copper piping and fittings, CPVC, or listed relief valve drain tube with fittings which will not reduce the internal bore of the pipe or tubing (straight lengths as opposed to coils) and shall extend from the valve to the outside of the building with the end of the pipe not more than two (2) feet (610mm) nor less than six (6) inches (152mm) above the ground or the flood level of the area receiving the discharge and pointing downward. Such drains may terminate at other approved locations. No part of such drainpipe shall be trapped or subject to freezing. The terminal end of the drainpipe shall not be threaded.

Applicable Watts Product for UPC Code Section 608.4:

WATTS SERIES 100XL

Temperature and Pressure Relief Valves ($3/4"$)

Specifications:

Each hot water storage heater shall be equipped with an CSA and A.S.M.E. rated automatic temperature and pressure relief valve to protect the heater from excessive pressure and temperature. The device shall be ANSI Z21.22 certified. The BTU discharge capacity of the device shall be in excess of the BTU input rating of the heater. The valve shall be a Watts Regulator Company Series 100XL.



Watts Series
100XL

Applicable Watts Product for UPC Code Section 608.4:

WATTS SERIES 40, 140, 240 & 340

Commercial Capacity T&P Relief Valves ($3/4"$ - $2"$)

Specifications:

Each hot water storage heater shall be equipped with an automatic temperature and pressure relief valve to protect the heater from excessive pressure and excessive temperature. The device shall be certified as meeting the requirements of ASME low pressure heating boiler code and ANSI Z21.22. The BTU discharge capacity of the device shall be in excess of the BTU input rating of the heater. The valve shall be a Watts Regulator Company Series 40, 140, 240 and 340.



Watts Series
40, 140,
240 & 340

Applicable Watts Product for UPC Code Section 608.5:

WATTS MODELS 100DT & 100DT-A

Temperature and Pressure Relief Valve Drain Lines

Specifications:

Residential water heaters having relief valves with $3/4"$ outlets shall be equipped with a relief valve drain line. Drain line shall be constructed to conform with AGA ER48-22 and shall meet the requirements of the Department of Housing and Urban Development. The drain line shall be constructed so as to be able to withstand inlet steam pressure of 15psi or 250°F. Provisions shall be made so that discharge from the drain line will not cause personal injury or property damage. Temperature and pressure drain line shall be a Watts Regulator Company model 100DT or 100DT-A.



Watts Models 100DT and 100DT-A

UPC 2000 CODE - CHAPTER 6 - WATER SUPPLY AND DISTRIBUTION

UPC 2000 Section 608 Water Pressure, Pressure Regulators, Pressure Relief Valves, and Vacuum Relief Valves - cont'd

608.6 Any water heating device connected to a separate storage tank and having valves between said heater and tank shall be provided with an approved water pressure relief valve.

608.7 Vacuum Relief Valves. Where a hot water storage tank or an indirect water heater is located at an elevation above the fixture outlets in the hot water system, a vacuum relief shall be installed on the storage tank or heater.

Applicable Watts Product for UPC Code Section 608.6:

WATTS SERIES 174A

ASME Water Pressure Relief Valve for Residential Applications ($3/4"$ - $2"$)

Specifications:

An ASME Section IV certified pressure relief valve shall be installed on each pressure tank as noted. The relief valve shall be set to relieve at the maximum working pressure of the tank. The valve shall feature a raised seat and non-mechanical disc alignment. Working parts and spring shall be isolated from any discharge by a high temperature resistant material. Valve shall be a Watts Regulator Company Series 174A.



Watts Series 174A

Applicable Watts Product for UPC Code Section 608.7:

WATTS SERIES N36

Vacuum Relief Valve ($1/2"$, $3/4"$)

Specifications:

The valve shall be installed on domestic hot water supply tanks/ heaters/unit heaters/ steam kettles as indicated on plans. The vacuum relief valve shall be ANSI Z21.22 rated and CSA certified. The vacuum relief valve shall have an all brass body and include a protective cap. The valve shall be a Watts Regulator Company Series N36.



Watts Series N36

UPC 2000 Section 609 Installation, Testing, Unions, and Location

609.5 Unions. Unions shall be installed in the water supply piping within twelve (12) inches (305 mm) of regulating equipment, water heating, conditioning tanks, and similar equipment which may require service by removal or replacement in a manner which will facilitate its ready removal.

609.8 Low Pressure Cutoff Required on Booster Pumps for Water Distribution Systems. When a booster pump – excluding a fire pump – is connected to a water service or underground water pipe, a low-pressure cutoff switch on the inlet side of the pump shall be installed within five (5) feet (1524 mm) of the inlet. The cutoff switch shall be set for not less than ten (10) psi (68.9 kPa) or as required by the Administrative Authority. A pressure gauge shall be installed between the shutoff valve and the pump.

Applicable Watts Product for UPC Code Section 609.5:

WATTS SERIES B-6010

Specifications:

Valves shall be 2-piece construction, ASTM B-584 bronze body, ASTM B-16 or ASTM B-124 brass ball with chrome plating, blow-out proof ASTM B-16 brass stem, reinforced stem packing and stem thrust bearing. Valves shall be pressure rated to 600 psi (41 bars) WOG non-shock at 150° F (66°C). Valves shall have female NPT or solder end union connection x female NPT or solder connection. The valve shall be a Watts Regulator Company B-6010 threaded or B-6011 solder end.



Watts Series B-6010

Applicable Watts Product for UPC Code Section 609.8:

WATTS SERIES 116/1116

Water Pressure Reducing Valve (1¹/₄" - 24")

Specifications:

Watts Series 116/1116 installed on a bypass line, main line pressure is accurately controlled by relief of excess pressure. Installed in the main line, pilot controls piped to the suction side of the pump, prevent upstream pressure from dropping below a preset minimum.

Body shall be ductile iron ANSI B16.1 fusion bond epoxy coated, inside and out. Diaphragm actuated by hydraulic pilot. Valves shall be appropriate for dead end service. All elastomers shall be of FDA approved materials. Seat shall be renewable 316 stainless steel. The disc shall be quad seal retained on three sides by the disc holder. Disc holder shall be configured to create a needle valve for smooth laminar flow over the seat when low flows are required. Disc/ diaphragm assembly shall be top and bottom guided to assure proper disc/seat alignment. Raised sharp seats will not be accepted. The valve shall be a Watts Regulator Company Series 116/1116. Consult your local Watts agent for sizing and application help.

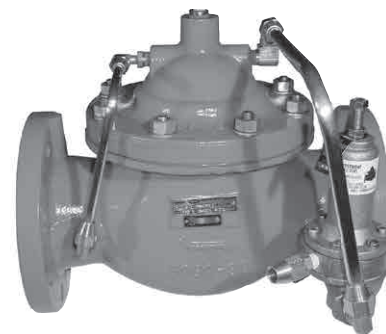

Watts Series 116

UPC 2000 Section 609 Installation, Testing, Unions, and Location

609.10 Water Hammer. All building supply systems in which quick-acting valves are installed shall be provided with devices to absorb the hammer caused by high pressures resulting from the quick closing of these valves. These pressure-absorbing devices shall be either air chambers or approved mechanical devices. Water pressure absorbing devices shall be installed as close as possible to quick-acting valves.

Applicable Watts Product for UPC Code Section 609.10:

WATTS SERIES 15

Water Hammer Arrestors (1/2" - 2")

Specifications:

Water hammer arrestors shall be Watts Regulator Company Series 15. They must be ASSE Standard 1010 approved, ANSI A112.26.1M approved, P.D.I. WH201 approved and certified.

Construction shall be: **Bodies** - Hard drawn copper with custom internal mirror finish, **Piston** - Threaded adapter and cap machined of free cutting brass, **Seals** - O-Rings made of EPDM, **Seal Lubricant** - Dow-Corning silicone compound #111, FDA approved. **Operating Pressure** - 150 psi. **Temperature Range** - 33°F - 180°F. Valves must be able to operate properly in any position and be factory pre-charged, permanently capped and epoxy sealed.



Watts Series 15

UPC 2000 CODE - CHAPTER 10 - TRAPS AND INTERCEPTORS

UPC 2000 Section 1007 Trap Seal Protection

1007.0 Trap Seal Protection. Floor drain or similar traps directly connected to the drainage system and subject to infrequent use shall be provided with an approved automatic means of maintaining their water seals, except where not deemed necessary for safety or sanitation by the Administrative Authority. When automatic trap priming devices are installed, they shall be accessible for maintenance.

Applicable Watts Product for UPC Code Section 1007.0:

WATTS SERIES A200

Flow-Through Trap Primer (1/2")

Specifications:

A trap primer shall be installed in plumbing systems to prevent floor drain traps from losing their water seal by evaporation. Maintaining the water seal will prevent the backflow of sewer gas into the buildings or rooms where the traps are installed. Trap primers are specified in various plumbing codes such as IAPMO, Southern Standard Building Code, National Standard Plumbing Code and many state and local plumbing codes in U.S.A. and Canada. The device shall meet the requirements of ASSE Standard 1018. The trap primer shall be a Watts Regulator Company Series A200T (threaded), or A200S (solder).



Watts Series A200

UPC 2000 CODE - CHAPTER 13 - HEALTH CARE FACILITIES AND MEDICAL GAS AND VACUUM SYSTEMS

UPC 2000 Section 1308 Aspirators

1308.1 Water Inlets to Water Supplied Aspirators. Provisions for aspirators or other water-supplied suction devices shall be installed only with the specific approval of the Administrative Authority. Where aspirators are used for removing body fluids, they shall include a collecting bottle or similar fluid trap. Aspirators shall indirectly discharge to the sanitary drainage system through an air gap in accordance with Chapter 8. The potable water supply to an aspirator shall be protected by a vacuum breaker or equivalent backflow protection device in accordance with Section 603.0.

Applicable Watts Product for UPC Code Section 1308.1:

WATTS SERIES 008PCQT

Health Hazard Vacuum Breaker, Anti-Siphon, Spill Resistant ($3/8"$ - $1"$)

Specifications:

A spill-resistant vacuum breaker (SVB) shall be installed in accordance with the manufacturer's instructions, as noted on the plans. The valve shall consist of a one-piece modular check and float assembly made of engineered thermoplastic and housed in a bronze body. Springs shall be stainless steel. The valve shall be constructed with a molded diaphragm separating the air inlet from the potable water supply to prevent spillage. The valve shall be a Watts Regulator Company Series 008PCQT.



Watts Series 008PCQT

Applicable Watts Product for UPC Code Section 1308.1:

WATTS SERIES 009

Reduced Pressure Zone Backflow Preventer ($1/4"$ - $3"$)

Specifications:

A reduced pressure zone backflow preventer shall be installed at each potential health hazard location to prevent backflow due to backsiphonage and/or back-pressure. The assembly shall consist of an internal pressure differential relief valve located in a zone between two positive seating check modules with captured springs and silicone seat discs. Seats and seat discs shall be replaceable in both check modules and the relief valve. There shall be no threads or screws in the waterway exposed to line fluids. Service of all internal components shall be through a single access cover secured with stainless steel bolts. The assembly shall also include two resilient seated isolation valves, four resilient seated test cocks and an air gap drain fitting. The assembly shall meet the requirements of: USC Manual 8th Edition; ASSE Standard 1013; AWWA Standard C511; CSA B64.4. The valve shall be a Watts Regulator Company Series 009.

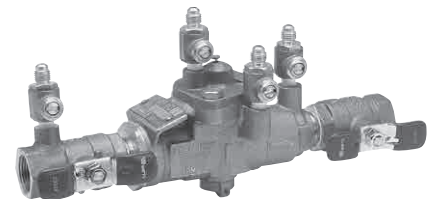

Watts Series 009

WATTS REGULATOR BACKFLOW PREVENTION GUIDE

For protection of the potable water supply

This “guide” is offered to simplify the selection of backflow assemblies and to ensure that the most suitable assembly is applied to protect against cross connections based on the degree of hazard and the comparative cost.

Degree of hazard is determined by whether the substance in the non-potable system is “toxic” (treated boiler water etc.), or “non-toxic” (sugar, soda pop etc.). Since this “degree of hazard” subject is often a matter of code interpretation, we offer this data as a helpful guide and **suggest you consult your local code authority**. However, it is based on a consensus of plumbing and health codes surveyed throughout the country, and we hope it will be useful as a condensation of this very broad subject.

Watts has the most extensive line of products to provide you with alternate choices to meet a specific condition. We also have conveniently located sales engineering offices throughout the country, that are available to assist you in cross connection control programs and educational meetings. Thus you can depend on both the Watts line and the Watts organization.

Installation	Watts Recommended Products	Governing Standards
Air Compressors	Air Gap	
Air Conditioning.....	909/009/995.....	ASSE Std 1013
Air Conditioned Chill Water.....	909/009/995.....	ASSE Std 1013
Air Conditioned Condenser Water.....	909/009/995.....	ASSE Std 1013
Air Conditioned Cooling Towers.....	909/009/995.....	ASSE Std 1013
Air Washers	Air Gap	
Aspirator, Medical.....	288A/909/009/995.....	ASSE Std 1013
Aspirator, Herbicide & Root Feeders.....	#8.....	ASSE Std 1011
Autoclave & Sterilizer.....	288A.....	ASSE Std /1011/1001
Autopsy Tables.....	288A/008.....	ASSE Std 1001/1020/1056
.....	909/009/995.....	ASSE Std 1013
Baptismal Fount.....	9D.....	ASSE Std 1012
Bathtub Below Rim Filler.....	9D.....	ASSE Std 1012
Bedpan Washer, Flushing Rim.....	288A/008/800.....	ASSE Std 1001/1020/1056
Beverage Dispensing Machines.....	SD3.....	ASSE Std 1022
Bidet.....	288A/388ASC.....	ASSE Std 1001
Boiler, Residential Feed Line.....	9D.....	ASSE Std 1012
Boiler, Industrial Feed Line.....	909/009/995.....	ASSE Std 1013
Brine Tank.....	Air Gap	
Bottle Washer*.....	288A or 008/800.....	ASSE Std 1001/1020/1056
Carbonated Beverage		
Vending Machine.....	SD3.....	ASSE Std 1022
Chemical Feeder Tanks.....	909/009/995.....	ASSE Std 1013
Chiller Tanks.....	9D.....	ASSE Std 1012
Chlorinator.....	9D.....	ASSE Std 1012
Coffee Urn.....	288A/388ASC.....	ASSE Std 1001
Cooking Kettles.....	288A/388ASC.....	ASSE Std 1001
Condensate Tanks.....	Air Gap	
Cuspidor, Dental.....	288A/388ASC.....	ASSE Std 1001
Dairy Equipment*.....	288A/008/800.....	ASSE Std 1001/1020/1056
Degreasing Equipment.....	909/009/995.....	ASSE Std 1013
Detergent Dispenser*.....	288A/008.....	ASSE Std 1001/1056
Developing Tanks*, Photo.....	288A/008.....	ASSE Std 1001/1056
Digesters, Hospital.....	909/009/995.....	ASSE Std 1013
Commercial Dishwasher*.....	288A/008.....	ASSE Std 1001/1056
Drinking Fountain.....	Air Gap	
Dye Vats & Tanks.....	909/009/995.....	ASSE Std 1013
Etching Tanks.....	909/009/995.....	ASSE Std 1013
Fountain, Livestock Drinking.....	9D.....	ASSE Std 1012
Fountain, Ornamental.....	909/009/995.....	ASSE Std 1013
Garbage Can Washer.....	9D.....	ASSE Std 1012
Garbage Disposers.....	288A.....	ASSE Std 1001
Hose Faucets.....	8/NF8/8FR.....	ASSE Std 1011

UPC 2000 CODE - WATTS REGULATOR BACKFLOW PREVENTION GUIDE cont'd

Installation	Watts Recommended Products	Governing Standards
Humidifier Tank & Boxes.....	288A.....	ASSE Std 1001
Hydrotherapy Baths	288A/388ASC	ASSE Std 1001
Irrigation System*	909/009/995.....	ASSE Std 1013/1020
Janitor Closets	8.....	ASSE Std 1011
Laundry Machine, Hospital	909/009/995.....	ASSE Std 1013
Lavatory.....	Air Gap	
Lawn Sprinkler *	288A/909/009/995/800	ASSE Std 1001/1013/1020
Lawn Sprinkler, Chemical Injection.....	909/009/995.....	ASSE Std 1013
Main Line (Potable Water).....	909/009/995.....	ASSE Std 1013
Make-Up Tank.....	9D.....	ASSE Std 1012
Marina, Boat Connections	8/7/Cu7	ASSE Std 1011/1024
Mobile Homes	7/Cu7	ASSE Std 1024
Pipette Washer.....	288A.....	ASSE Std 1001
Photo Lab Sinks.....	288A.....	ASSE Std 1001
Potato Peeler.....	Air Gap	
Processing Tanks.....	909/009/995.....	ASSE Std 1013
Pump Prime Lines.....	9D.....	ASSE Std 1012
Pump, Water Oper Eject	9D.....	ASSE Std 1012
Recirculated Water.....	909/009/995.....	ASSE Std 1013
Residential Supply Service.....	7/Cu7	ASSE Std 1024
Reclaim Pit	288A.....	ASSE Std 1001
Serrated Faucets (Lab).....	NLF9	ASSE Std 1035
Sewer Flushing Manhole.....	288A.....	ASSE Std 1001
Shampoo Basin Hose Rinse	288A or N9CD	ASSE Std 1001/1052
Sinks, Wash-Up	Air Gap	
Sitz Bath.....	288A.....	ASSE Std 1001
Sizing Vats & Boxes	709/007/775.....	ASSE Std 1015
Soap Mixing Tank	288A.....	ASSE Std 1001
Solution Tanks.....	909/009/995.....	ASSE Std 1013
Sprinkler System, Fire Protection**.....	709/709DCDA/909/909RPDA	ASSE Std 1015/1048/1013/1047
Starch Tanks	709/007/775.....	ASSE Std 1015
Steam Cleaner Connection.....	8.....	ASSE Std 1011
Steam Table	288A/388ASC	ASSE Std 1001
Stills*.....	288A/008	ASSE Std 1001/1056
Swimming Pool, Commercial	709/007/775.....	ASSE Std 1015
Telephone Showers.....	S8.....	ASSE Std 1011
Trap Primer.....	A200.....	ASSE Std 1018
Ultrasonic Cleaner.....	288A.....	ASSE Std 1001
Urinal, Trough.....	9D.....	ASSE Std 1012
Wall Hydrants	8/NF8/8FR	ASSE Std 1011
Wall Hydrants, Frost Free	NF8/8FR.....	ASSE Std 1011
Water Treatment Tanks.....	709/007/775.....	ASSE Std 1015
Water Well Secondary System	909/009/995.....	ASSE Std 1013

* Indicates the possibility of continuous pressure and or back pressure. Use products meeting the following standards if either condition is present. ASSE Std 1013 and 1056.

** Indicates anti-freeze is present in the system. Use products meeting ASSE 1047 or 1013.

Note: all ASSE standards are now listed as ANSI/ASSE standards.

Notes

Notes

Notes

For Technical Assistance Call Your Authorized Watts Agent.

			Telephone #	Fax #
	HEADQUARTERS: Watts Regulator Company	815 Chestnut St., North Andover, MA 01845-6098 U.S.A.	978 688-1811	978 794-1848
North East	Vernon Bitzer Associates, Inc.	980 Thomas Drive, Warminster, PA 18974	215 443-7500	215 443-7573
	Edwards, Platt & Deely, Inc.	271 Royal Ave., Hawthorne, NJ 07506	973 427-2898	973 427-4246
	Edwards, Platt & Deely, Inc.	368 Wyandanch Ave., North Babylon, NY 11703	631 253-0600	631 253-0303
	J. B. O'Connor Company, Inc.	P.O. Box 12927, Pittsburgh, PA 15241	724 745-5300	724 745-7420
	The Joyce Agency, Inc.	8442 Alban Rd., Springfield, VA 22150	703 866-3111	703 866-2332
	W. P. Haney Co., Inc.	51 Norfolk Ave., South Easton, MA 02375	508 238-2030	508 238-8353
	WMS Sales, Inc. (Main office)	9580 County Rd., Clarence Center, NY 14032	716 741-9575	716 741-4810
South East	Billingsley & Associates, Inc.	5609-D Salmen St., Harahan, LA 70123	504 733-7624	504 733-6904
	Billingsley & Associates, Inc.	478 Cheyenne Lane, Madison, MS 39110	601 856-7565	601 856-8390
	Francisco J. Ortiz & Co., Inc.	Charlyn Industrial Pk., Road 190 KM1.9 - Lot #8, Carolina, Puerto Rico 00983	787 769-0085	787 750-5120
	Mid-America Marketing, Inc.	2776 B.M. Montgomery St., Birmingham, AL 35209	205 879-3469	205 870-5027
	Mid-America Marketing, Inc.	1364 Foster Avenue, Nashville, TN 37210	615 259-9944	615 259-5111
	Mid-America Marketing, Inc.	5466 Old Hwy. 78, Memphis, TN 38118	901 795-0045	901 795-0394
	RMI	Glenfield Bus. Ctr., 2535 Mechanicsville Tpk., Richmond, VA 23223	804 643-7355	804 643-7380
	Smith & Stevenson Co., Inc.	4935 Chastain Ave., Charlotte, NC 28217	704 525-3388	704 525-6749
	Spotswood Associates, Inc.	6235 Atlantic Blvd., Norcross, GA 30071	770 447-1227	770 263-6899
	Target Marketing Enterprises, Inc.	118 West Grant St., Building M, Orlando, FL 32806	407 245-7838	407 245-7833
South Central	Hugh M. Cunningham, Inc.	13755 Benchmark, Dallas, TX 75234	972 888-3800	972 888-3838
	Mack McClain & Associates	11132 South Towne Square, Suite 202, St. Louis, MO 63123	314 894-8188	314 894-8388
	Mack McClain & Associates, Inc.	1537 Ohio St., Des Moines, IA 50314	515 288-0184	515 288-5049
	Mack McClain & Associates, Inc.	15090 West 116th St., Olathe, KS 66062	913 339-6677	913 339-9518
	Phoenix Marketing, Ltd.	2416 Candelaria N.E., Albuquerque, NM 87107	505 883-7100	505 883-7101
Pro-Spec, Inc.	P.O. Box 472226, Tulsa, OK 74147-2226	918 461-0066	918 461-0105	
North Central	Associated Independent Marketing	1606 Commerce Dr., Sun Prairie, WI 53590	608 837-5005	608 837-2368
	Dave Watson Associates	1325 West Beecher, Adrian, MI 49221	517 263-8988	517 263-2328
	Disney-McLane-Woodcock, Inc.	428 McGregor Ave., Cincinnati, OH 45206	800 542-1682	877 476-1682
	Disney-McLane-Woodcock, Inc.	17610 S. Waterloo Rd., Cleveland, OH 44119	216 486-1010	216 486-2860
	Mid-Continent Marketing Services Ltd.	1724 Armitage Ct., Addison, IL 60101	630 953-1211	630 953-1067
South West	Delco Sales, Inc.	2267 Yates Ave., Los Angeles, CA 90040	323 890-9250	323 724-5227
	P I R Sales, Inc.	3050 North San Marcos Place, Chandler, AZ 85225	480 892-6000	480 892-6096
	R. C. Hartnett & Associates	30852 Huntwood Ave., Hayward, CA 94544	510 471-7200	510 471-4441
North West	Delco Sales, Inc.	111 Sand Island Access Rd., Unit I-10, Honolulu, HI 96819	808 842-7900	808 842-9265
	Fanning & Associates, Inc.	6765 Franklin St., Denver, CO 80229-7111	303 289-4191	303 286-9069
	Hollabaugh Brothers & Associates	1260 6th Ave. South, Seattle, WA 98134-1308	206 467-0346	206 467-8368
	Hollabaugh Brothers & Associates	3028 S.E. 17th Ave., Portland, OR 97202	503 238-0313	503 235-2824
	R. E. Fitzpatrick Sales, Inc.	4109 West Nike Dr. (8250 South), West Jordan, UT 84088	801 282-0700	801 282-0600
	Soderholm & Associates, Inc.	7150 143rd Ave. N.W., Anoka, MN 55303	763 427-9635	763 427-5665
CANADA	Watts Industries (Canada) Inc. (Watts Regulator Co. Division)	5435 North Service Road, Burlington, Ontario L7L 5H7	905 332-4090	905 332-7068
	GTA Sales Team.	Greater Toronto Area	888 208-8927	888 479-2887
	Hydro-Mechanical Sales, Ltd.	3700 Joseph Howe Dr., Ste. 1 Halifax, Nova Scotia B3L 4H7	902 443-2274	902 443-2275
	Hydro-Mechanical Sales, Ltd.	297 Collishaw St., Ste. 7 (shipping) Moncton, New Brunswick E1C 9R2	506 859-1107	506 859-2424
	Hydro-Mechanical Sales, Ltd.	85 Tolt Rd., St. Phillips, Newfoundland A1B 3M7	709 895-0090	709 895-0091
	Le Groupe B.G.T., Inc.	2800 Rue Dalton Ste. 3, Ste-Foy, Quebec G1P 3S4	418 657-2800	418 657-2700
	Le Groupe B.G.T., Inc.	140 Rue Merizzi, Ville St. Laurent, Quebec H4T 1S4	514 341-9010	514 341-4464
	Walmar Mechanical Sales	24 Gurdwara Rd., Nepean, Ontario K2E 8B5	613 225-9774	613 225-0673
	Mar-Win Agencies, Ltd.	1123 Empress St., Winnipeg, Manitoba R3E 3H1	204 775-8194	204 786-8016
	Palsler Enterprises, Ltd.	1885 Blue Heron Dr., #4, London, Ontario N6H 5L9	519 471-9382	519 471-1049
	Northern Mechanical Sales	P.O. Box 280 (mailing) 163 Pine St. (shipping), Garson, Ontario P3L 1S6	705 693-2715	705 693-4394
	RAM Mechanical Marketing	441 Quebec St., Regina, Saskatchewan S4R 1K8	306 525-1986	306 525-0809
	RAM Mechanical Marketing	2615-B Wentz Avenue, Saskatoon, Saskatchewan S7K 5J1	306 244-6622	306 244-0807
	Con-Cur West Marketing, Inc.	#109-42 Fawcett Rd., Coquitlam, British Columbia V3K 6X9	604 540-5088	604 540-5084
	D.C. Sales, Ltd.	10-6130 4th St. S.E., Calgary, Alberta T2H 2A6	403 253-6808	403 259-8331
	D.C. Sales, Ltd.	11420 142 Street, Edmonton, Alberta T5M 1V1	780 496-9495	780 496-9621
0213	EXPORT Hdqtrs.: Watts Regulator Co.	815 Chestnut St., North Andover, MA 01845-6098 U.S.A.	978 688-1811	978 794-1848



USA: Tel: (978) 689-6066 • Fax: (978) 975-8350 • Watts.com

Canada: Tel: (905) 332-4090 • Fax: (905) 332-7068 • Watts.ca

Latin America: Tel: (52) 81-1001-8600 • Watts.com