

For Commercial and Industrial Applications

Job Name _____

Contractor _____

Job Location _____

Approval _____

Engineer _____

Contractor's P.O. No. _____

Approval _____

Representative _____

Series FBV-3, FBVS-3

2-Piece, Full Port, Brass Ball Valves

Sizes: 1/4" – 3" (8-80mm)

Series FBV-3, FBVS-3 2-Piece, Full Port, Brass Ball Valves are used in commercial and industrial applications for a full range of liquids and gases. They feature a bottom-loaded blowout-proof stem, virgin PTFE seats, thrust washer, and adjustable stem packing gland, stem packing nut, chrome plated brass ball, brass adapter, and steel handle.

Features

- Suitable for a full range of liquids and gases
- Minimal pressure drop due to full size ports
- Bottom loaded, blow-out proof stem
- Virgin PTFE stem packing seal, thrust washer and seats
- Vinyl insulator on heavy duty, zinc plated carbon steel handles
- Fast quarter-turn open or close operation
- Excellent for throttling and balancing applications of nonabrasive fluids where minimum flow is 20% to 100% of valve capacity
- Low operating torque
- Adjustable stem packing gland
- Stem O-ring seal

Models

FBV-3 1/4" – 3" (8-80mm) with threaded connections

FBVS-3 1/2" – 3" (15-80mm) with solder connections

Pressure – Temperature

Temperature Range: -40° F – 400° F (-40°C – 204°C)

Pressure Ratings:

FBV-3

1/4" – 2" (8 – 50mm)

600psi (41 bars) WOG, non-shock

150psi (10.3 bars) WSP

2 1/2" – 3" (65 – 80mm)

600psi (41 bars) WOG, non-shock

125psi (8.6 bars) WSP

FBVS-3

1/2" – 2" (15 – 50mm)

600psi (41 bars) WOG, non-shock

150psi (10.3 bars) WSP

2 1/2" – 3" (65-80mm)

400psi (27.5 bars) WOG, non-shock

125psi (8.6 bars) WSP

*This valve is designed to be soft soldered into lines without disassembly, using a low temperature solder to 420°F (216°C). Higher temperature solders may damage the seat material.

Apply heat with the flame directed **AWAY** from the center of the valve body. Excessive heat can harm the seats. After soldering, the packing nut may have to be tightened.

Watts product specifications in U.S. customary units and metric are approximate and are provided for reference only. For precise measurements, please contact Watts Technical Service. Watts reserves the right to change or modify product design, construction, specifications, or materials without prior notice and without incurring any obligation to make such changes and modifications on Watts products previously or subsequently sold.

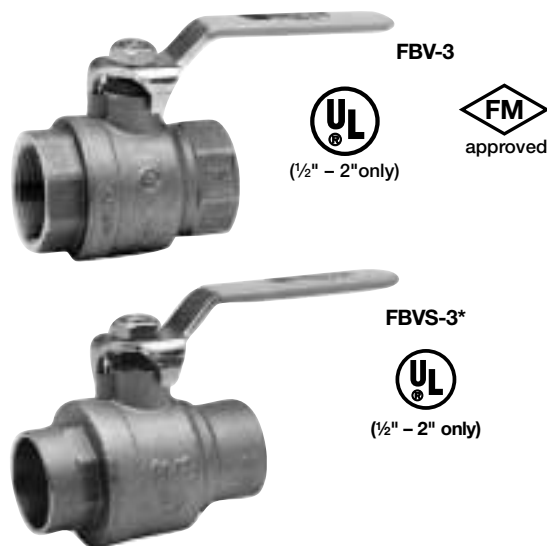

Approvals

1/2" – 2" (15-50mm) FBV-3 UL/FM approved

1/2" – 2" (15-50mm) FBVS-3 UL listed

Valves comply with MSS-SP-110 standards



Gas Approvals (Threaded Valves Only)

1/2" – 2" (15-50mm)

ASME B16.33, CSA 

1/2psig and 5psig (14 and 34 kPa) @ -40°F – 125°F (-40°C - 52°C)

125psig (8 bars) @ -40°F – 125°F (-40°C to 52°C)

2 1/2" – 3" (65 – 88mm)

ASME B16.38, CSA

1/2psig and 5psig (14 and 34 kPa) @ -40°F – 125°F (-40°C – 52°C)

125psig (8 bars) @ -40°F – 125°F (-40°C to 52°C)

Specifications

Approved valves shall be 2-piece and constructed of forged brass body and end adapter. Ball shall be full port, chrome plated brass. Seats and stem packing shall be virgin PTFE. Bottom loaded, blowout proof stem shall be brass with a fluorocarbon elastomer O-ring and adjustable packing nut threaded to body. Valve sizes 1/4" – 2" shall be rated to 600psi (41 bars) WOG non-shock and 150psi (10.3 bars) WSP. Valve sizes 2 1/2" – 3" (threaded) shall be rated to 600psi (41 bars) WOG non-shock and 125psi (8.6 bars) WSP. Valve sizes 2 1/2" – 3" (solder) shall be rated to 400psi (27.5 bars) WOG non-shock and 125psi (8.6 bars) WSP. Valves shall be equal to Watts FBV-3 (threaded) or FBVS-3 (solder).



Materials

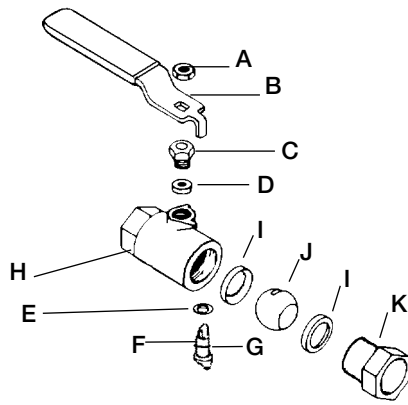

- A. Handle Nut Zinc plated carbon steel
- B. Handle Zinc plated carbon steel with vinyl insulator
- C. Packing Nut Brass
- D. Stem Packing Virgin PTFE
- E. Thrust Washer Virgin PTFE
- F. Stem Machined brass
- G. O-ring Fluorocarbon elastomer (FKM)
- H. Body Forged brass
- I. Seats Virgin PTFE
- J. Ball Chrome plated brass
- K. Adaptor Forged brass

Flow Curves

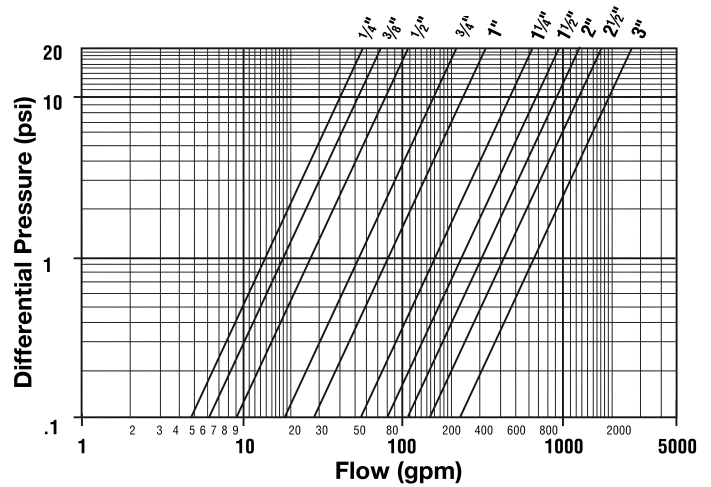

Temperature/Pressure Rating

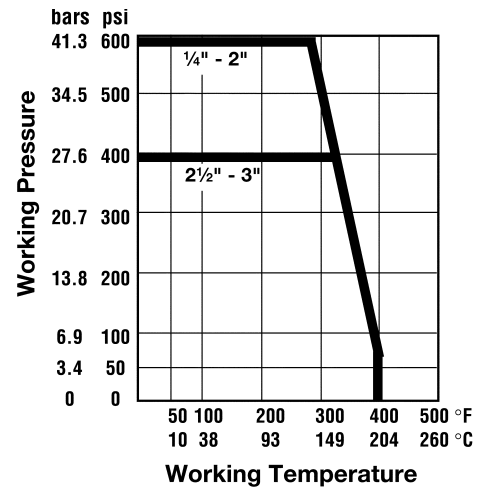

*See applicable note on reverse side for solder end valves with regards to pressure/temperature rating.

Dimensions - Weights

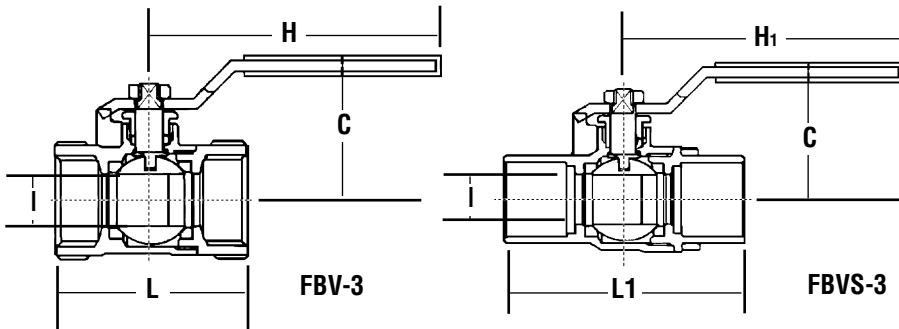

SIZE (DN)		DIMENSIONS										WEIGHT			
in.	mm	C		H		H ₁		I		L		L ₁		lbs.	kg.
		in.	mm	in.	mm	in.	mm	in.	mm	in.	mm	in.	mm		
1/4	8	1 7/16	36	3 3/16	81	—	—	3/8	10.5	1 13/16	46	—	—	.3	.1
3/8	10	1 7/16	36	3 3/16	81	—	—	3/8	10.5	1 13/16	46	—	—	.3	.1
1/2	15	1 15/16	50	3 5/8	91	3 5/8	91	19/32	12.5	2 3/8	60	2 1/8	53	.5	.2
3/4	20	2 1/16	52	4 1/2	114	4 1/2	114	1 3/16	20.0	2 11/16	68	2 13/16	72	.8	.3
1	25	2 7/16	62	4 15/16	125	4 15/16	125	1	25.0	3 1/8	80	3 3/8	86	1.4	.6
1 1/4	32	2 5/8	66	4 15/16	125	4 15/16	125	1 1/4	31.0	3 11/16	90	3 7/8	98	2.0	.9
1 1/2	40	2 15/16	75	5 1/2	140	5 1/2	140	1 1/2	39.0	3 7/8	99	4 3/8	112	2.6	1.2
2	50	3 1/8	80	7 7/8	200	7 7/8	200	2	50.0	4 7/16	113	5 5/16	135	4.0	1.8
2 1/2	65	4 5/16	109	9 7/8	250	7 7/8	200	2 3/8	60.5	5 1/2	140	6 5/16	161	9.0	4.1
3	80	4 5/8	118	9 7/8	250	7 7/8	200	2 15/16	74.0	6 1/4	159	7 3/16	182	12.8	5.8



USA: 815 Chestnut St., No. Andover, MA 01845-6098; www.wattsreg.com
 Canada: 5435 North Service Rd., Burlington, ONT. L7L 5H7; www.wattscanada.ca