



ASSEMBLY AND TEST INSTRUCTION

Applicable Products:

All Watts purchased and manufactured products containing a UPC barcode and individual components as specified on production drawings or purchasing specifications.

ATI No. M.71.D**REV.: 1****EDP NO. 5001994****PAGE: 1 OF 11**

SUPERSEDES: ①

REV.	ALTERATIONS	ALERT	DATE	BY	ENG.	Q/A
0	Issue to production.	14N-9778	5/24/2013	AO	JAS	EG
1	Removed M.71.A, M.71.A1, M.71.C from SUPERSEDES.	14N-9781	10/16/2014	AO	JAS	EG

Scope:

This document specifies marking requirements for application of date code and manufacturer identification on all Watts Water Technologies (Watts) purchased and manufactured products that have a UPC barcode and individual components when specified. The purpose of this marking system is to provide traceability to the specific manufacturer and date of manufacture throughout a product or component's service life.

A. Individual Product / Component Requirements:

Date Code Format:

Date code will utilize six digits with code format **YYWWXX** as identified below:

Year of Manufacture identifier ("YY"): The first two digits of the code identify year of manufacture

Week of Manufacture ("WW"): The middle two digits will identify the week of manufacture of the component or finished product assembly. In the event that a fixed template or date stamping means is applied, a span of 1 week prior to and 1 week after the actual date of final product completion is acceptable. The production week is based on January 1st being start of year. Specific date code schedule is outlined in Table 1.

Supplier Code ("XX"): The final two digits will identify the supplier via an alphanumeric code. The alphanumeric code will utilize numeric digits 0 through 9 and upper case alphabetic characters A through Z with the letters I and O excluded. The supplier code is generated by converting the 6-digit decimal Supplier number in the Watts system to the two digit alphanumeric representation. *Note: Watts MRP system will automatically generate this code and populate field on Watts purchase orders and/or supplier schedules.*

Example conversion of 6-digit supplier number 156622.

The alphanumeric code representation of 156622 is GJ. The complete code for a product manufactured by this supplier in the 12th week of 2010 would be **1012GJ**.

Exception: The following Watts facilities will use the following single digit codes.

Webster Valve:	W
Regtrol:	R
TWVC:	T
WNV:	N



ASSEMBLY AND TEST INSTRUCTION

Applicable Products:

All Watts purchased and manufactured products containing a UPC barcode and individual components as specified on production drawings or purchasing specifications.

ATI No. M.71.D

REV.: 1

EDP NO. 5001994

PAGE: 2 OF 11

SUPERSEDES: ①

Product / Component Date Code Placement

Code is to be applied on all finished products containing a UPC barcode and on specific components as specified on the production drawing or purchasing specification. For finished products, refer to Table 2 for recommended marking location by product type. If the product is not listed or if a manufacturer is unable to mark in the recommended location, a marking location must be reviewed and agreed upon by supplier and Watts. Agreement is to be confirmed via formal approval issued by Watts (active production drawing or temporary marked-up drawing signed by Watts).

Placement must be in a location that is not in contact with final service media (i.e. internal wetted parts); it shall not be applied on surfaces used during installation and servicing. Wherever practical, the marking location on the item shall be selected to ensure readability during normal operational use. The main body in case of an assembly, or most pronounced surface on a fitting or component is the preferred location to apply the marking. In cases where product geometry or material form does not permit marking directly on principal surfaces, use of a nameplate, handle or tag securely attached to the product may be considered. Marking size shall satisfy the legibility requirements of this specification.

Permanency

Markings applied via direct product application, nameplate, handle or identification bands shall be as permanent as the normal life expectancy of the product/component and be capable of withstanding the environmental conditions experienced in normal application use. The directly applied identification marking method must ensure that the mark will withstand installation and service procedures and shall account for final finished condition of the item including paints, coatings, and sealants to assure readability. Refer to Table 3 for guidance on acceptable marking methods.

Legibility

Legibility shall be as required for human readability without magnification. The recommended minimum character height is .08 inches [2 mm]. In cases where component size or geometry does not permit use of characters per this minimum height, supplier must consult Watts to obtain approval of agreed upon configuration.

Type of lettering. Letters shall be all capital letters using either Arial or Helvetica font. Preferred font is Arial. Generating characters by automated processes (e.g., dot peen, laser, interactive graphics systems, stencils, or embossed stamp) shall be the preferred method. Example of all characters used for marking requirements specified in this ATI:
0123456789ABCDEFGHIJKLMNPQRSTUVWXYZ (Arial font 12-point BOLDFACE shown)



ASSEMBLY AND TEST INSTRUCTION

Applicable Products:

All Watts purchased and manufactured products containing a UPC barcode and individual components as specified on production drawings or purchasing specifications.

ATI No. M.71.D

REV.: 1

EDP NO. 5001994

PAGE: 3 OF 11

SUPERSEDES: ①

Table 1 – Week Code Values

Date of Product Manufacture	Week Code	Date of Product Manufacture	Week Code
January 1 - January 7	01	July 3 - July 9	27
January 8 - January 14	02	July 10 - July 16	28
January 15 - January 21	03	July 17 - July 23	29
January 22 - January 28	04	July 24 - July 30	30
January 29 - February 5	05	July 31 - August 6	31
February 6 - February 12	06	August 7 - August 13	32
February 13 - February 19	07	August 14 - August 20	33
February 20 - February 26	08	August 21 - August 27	34
February 27 - March 5	09	August 28 - September 3	35
March 6 - March 12	10	September 4 - September 10	36
March 13 - March 19	11	September 11 - September 17	37
March 20 - March 26	12	September 18 - September 24	38
March 27 - April 2	13	September 25 - October 1	39
April 3 - April 9	14	October 2 - October 8	40
April 10 - April 16	15	October 9 - October 15	41
April 17 - April 23	16	October 16 - October 22	42
April 24 - April 30	17	October 23 - October 29	43
May 1 - May 7	18	October 30 - November 5	44
May 8 - May 14	19	November 6 - November 12	45
May 15 - May 21	20	November 13 - November 19	46
May 22 - May 28	21	November 20 - November 26	47
May 29 - June 4	22	November 27 - December 3	48
June 5 - June 11	23	December 4 - December 10	49
June 12 - June 18	24	December 11 - December 17	50
June 19 - June 25	25	December 18 - December 24	51
June 26 - July 2	26	December 25 - December 31	52

Table 2: Date Code Marking Location Guide

Product Type / Family	Preferred Marking Location	Alternate Location
-----------------------	----------------------------	--------------------



ASSEMBLY AND TEST INSTRUCTION

Applicable Products:

All Watts purchased and manufactured products containing a UPC barcode and individual components as specified on production drawings or purchasing specifications.

ATI No. M.71.D
REV.: 1
EDP NO. 5001994
PAGE: 4 OF 11
SUPERSEDES: ①

Air Separators / Air Vents	Valve Body**	none
Automatic Control Valves	Valve Body**	Nameplate
Backflow Prevention Valves	Valve Body**	Nameplate
Balancing Valves	Valve Body**	none
Ball Valves	Valve Body**	Adapter
Boiler Drain Valves	Valve Body**	none
Boiler Level Controls	Valve Body**	Nameplate
Butterfly Valves	Valve Body**	none
Check Valves	Valve Body**	none
Corrugated Connectors	Nut	Exposed Tube OD
Di-electric Union Fittings	Tail piece	Adapter
Drainage Products	Body	Cover
Electronic Products	Primary Circuit Board	Nameplate
Escutcheons	Non-exposed back side	none
Expansion Tanks	External Tank shell	Nipple Flats
Faucets	Valve Body Under Spout	near UPC markings
Filtration Equipment	Body and Filter Bowls	Nameplate
Fittings (Quick-Connect, PEX)	Fitting Body	none
Float Valves	Valve Body**	none
Flow Checks	Valve Body**	Bonnet
Flow Switches	Valve Body**	none
Gate Valves	Valve Body**	Bonnet
Gauges	Gage Housing	none
General Fittings / Saddle Valves	Fitting Body	none
Globe Valves	Valve Body**	Bonnet
Hose Bibbs	Valve Body**	none
Hose Connection Vacuum Breakers	Valve Body**	none
Hydronics Fill Valves	Valve Body**	Cage
Hydronics Isolation Valves	Valve Body**	Adapter
Kitchen Sink Strainers	Strainer Body: Bottom of strainer body	none
Metal Tubular / Bath Wastes	All tubes / castings near the threaded end	none
Metering Valves	Valve Body**	none
Pipe and Tubing	Outside surface with standard markings	none
Pipe Nipples	Non-threaded External Surface	none
Plastic Tubular / Bath Wastes	All tubes near the threaded end	none
Pressure Regulators	Valve Body**	Nameplate
Relief / Bypass Valves	Valve Body**	Nameplate
Strainers (Wyes : Water filtration)	Valve Body**	none
Tempering Valves	Valve Body**	none
Trap Primers	Valve Body**	none
Vacuum Relief Valves	Valve Body**	none
Wall Hydrants	Valve Body** / Tube Extension	none
Washing Machine Shut-off Valves	Main Body & Elbows	none
Water Hammer Arrestors	Copper Tube	Brass Adapter Flats
Water Supply Hoses	Crimp Sleeve	Nut
Water Supply Stop Valves	Body Flats	none

** Note: Valve Body date code to appear near size or model marking.



ASSEMBLY AND TEST INSTRUCTION

Applicable Products:

All Watts purchased and manufactured products containing a UPC barcode and individual components as specified on production drawings or purchasing specifications.

ATI No. M.71.D
REV.: 1
EDP NO. 5001994
PAGE: 5 OF 11
SUPERSEDES: ①

TABLE 3. Marking Methods
(This table is given only as a guide)

Marking Methods	Mark Characteristics	Recommended Use
Blast (grit) (with pre-encoded stencils)	Variable depth or height	Abrasive method which can be used on most surfaces
Acid Etch (with pre-encoded stencils)		Characters produced by use of acid. Use on metal and glass
Vibro Peen		Metal or nonmetallic parts that may deform if metal stamped. Hand held operation.
Metal Stamp		Metal or nonmetal parts that will not deform under the stamping pressure required. Also, the alteration of the surface roughness finish will not be detrimental to proper functioning.
Dot peening		Metal or nonmetal parts that may deform if metal stamped.
Engraving		Sheet metal fabrication that will deform if metal stamped. Functional marking with color filler
Embossing		Thin sheet metal, plastics on nonfunctional surfaces
Cast or forged (with pre-encoded stencils)		Castings or forgings – characters raised or depressed depending on method of manufacture, unless otherwise specified on the drawing. Marking should be used on non-machined surfaces only
Molded (with pre-encoded stencils)		Usually plastic or rubber parts; may be either raised or depressed, unless otherwise specified.
Electro-chemical etch (electrolytic process)		Characters normally depressed, but may be raised. Used on fine surface finishes without protective coating, also high hardness parts (HRC 50 or higher)
Laser Discoloration	Surface mark	Heat from the laser discolors the material surface without associated metal removal
Laser (Paint pigmentation)		Chemicals added to some plastics that will react by changing color when contacted with a laser.
Laser (Bonding)	Raised mark	Mark produces by bonding a medium to the surface of an item, marking with a laser and producing a raised mark.
Laser (Engraving)	Variable depth	Very good resolution of alpha numeric and machine-readable marking symbology. Character height and width range from .007 to 4.0 inches.
Laser (Etching)		Generally limited to 0.001 inch max. depth, done at lower power settings
Laser markable Inks/Paints	Surface Mark	Inks and paints containing pigments that discolor when struck with a laser beam



ASSEMBLY AND TEST INSTRUCTION

Applicable Products:

All Watts purchased and manufactured products containing a UPC barcode and individual components as specified on production drawings or purchasing specifications.

ATI No. M.71.D

REV.: 1

EDP NO. 5001994

PAGE: 6 OF 11

SUPERSEDES: ①

B. Package Requirements:

Date Code Requirements:

All packaging utilized for individual product containment (bag or individual box) and for packaging multiple individual products (master carton) must have a date code applied on the product label itself or other location as directed per this specification. The date code is to accurately identify the date of packaging. Where inner cartons are packaged, both inner packaging and master containers must have this date code applied based on actual date of packaging.

Date Code Format:

Date code will utilize eight digits with code format **MM/DD/YY-XX** as identified below:

Month Packaged identifier (“MM”): The first two digits of the code identify the month product is packaged.

Day Packaged identifier (“DD”): The second set of two digits identify the actual day of the month the product is packaged.

Year of Manufacture identifier (“YY”): The third set of two digits identify the year.

Supplier Code (“XX”): The final two digits will identify the supplier via an alphanumeric code. The alphanumeric code will utilize numeric digits 0 through 9 and upper case alphabetic characters A through Z with the letters I and O excluded. The supplier code is generated by converting the 6-digit decimal Supplier number in the Watts system to the two digit alphanumeric representation. *Note: Watts MRP system will automatically generate this code and populate field on Watts purchase orders and/or supplier schedules.*

Example conversion of 6-digit supplier number 156622.

The alphanumeric code representation of 156622 is GJ. The complete code for a product packaged by this supplier on the 15th day of February in 2010 would be **02/15/10-GJ**.

Exception: The following Watts facilities will use the following single digit codes.

Webster Valve: W

Regtrol: R

TWVC: T

WNV: N

Permanency / Legibility:

Date code shall be applied using ink that is not water-soluble. Specific minimum character heights are defined below per each package type.

Type of lettering. Letters shall be all capital letters using either Arial or Helvetica font. Preferred font is Arial.

Carton Marking:



ASSEMBLY AND TEST INSTRUCTION

Applicable Products:

All Watts purchased and manufactured products containing a UPC barcode and individual components as specified on production drawings or purchasing specifications.

ATI No. M.71.D

REV.: 1

EDP NO. 5001994

PAGE: 7 OF 11

SUPERSEDES: ①

Date code must be stamped on cartons using a rubber stamp (not water-soluble ink), stencil or direct printing via ink jet. **DO NOT** hand write on the master or Inner carton. If date code is applied on pre-printed glossy labels, use of inkjet, stencil, screen or punch pin printing is to be used to print the Date code.

Acceptable

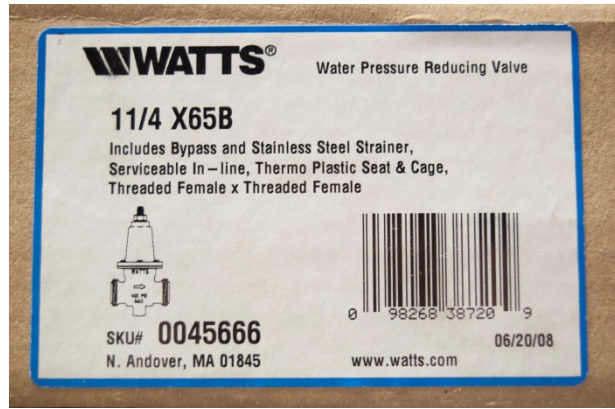

NOT Acceptable

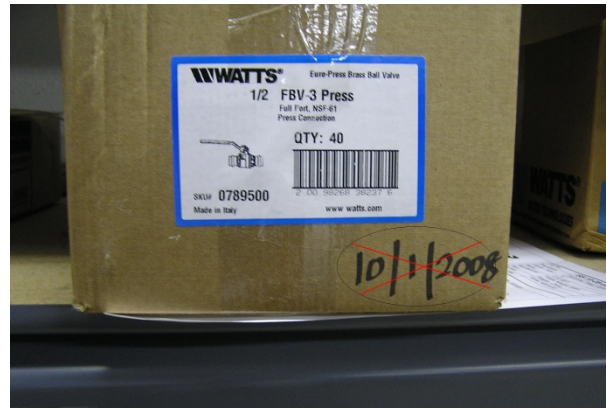

Master Carton: Master carton refers to a box that contains an individual or smaller quantity packaged units (Figure 1). For finished products containing a UPC barcode, date code shall be applied in location as shown in Figure 2. For manufacturers using print-on-demand labels, date code shall be printed as shown in Figure 3. Minimum acceptable character height for master carton date code shall be .25 inches [6.4 mm].

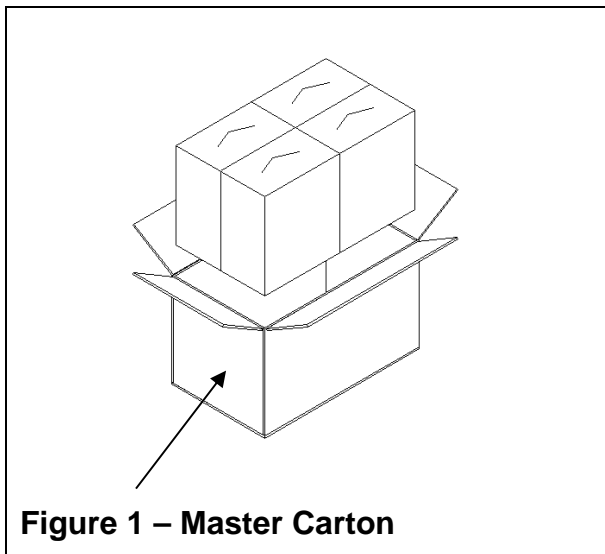

Figure 1 – Master Carton



ASSEMBLY AND TEST INSTRUCTION

Applicable Products:

All Watts purchased and manufactured products containing a UPC barcode and individual components as specified on production drawings or purchasing specifications.

ATI No. M.71.D

REV.: 1

EDP NO. 5001994

PAGE: 8 OF 11

SUPERSEDES: ①

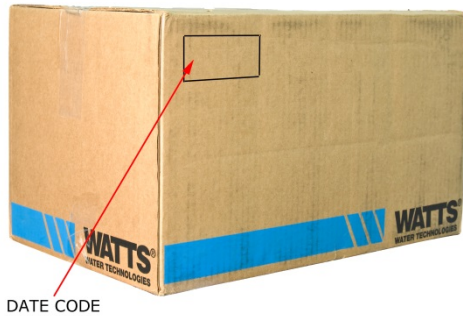

Figure 2 – Date Code Stamp Location



Figure 3 – Print-on-demand Label

Inner/Individual Plain Carton: Plain carton refers to a box with no pre-printed graphics of the product detail that it contains. Individual carton is a single pack unit and inner carton is multi pack unit that are placed into a master carton (Product in individual or inner case is identified by a pre-printed label). Minimum acceptable character height for inner/individual plain carton date code shall be .25 inches [6.4 mm].

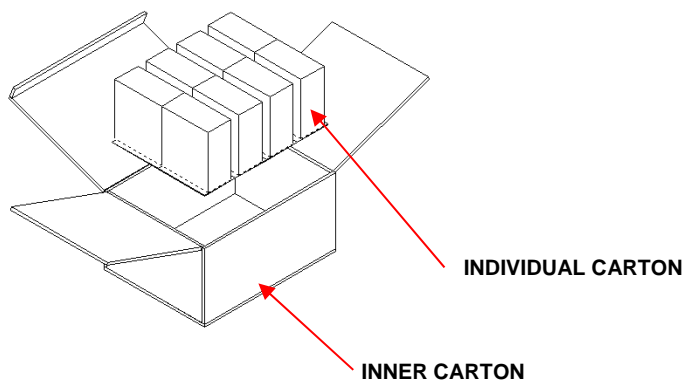

Figure 4 – Inner Carton (multi-pack) Example

For date coding inner and individual cartons refer to Figure 5. For placement of these cartons into a master carton refer to Figure 1.



ASSEMBLY AND TEST INSTRUCTION

Applicable Products:

All Watts purchased and manufactured products containing a UPC barcode and individual components as specified on production drawings or purchasing specifications.

ATI No. M.71.D

REV.: 1

EDP NO. 5001994

PAGE: 9 OF 11

SUPERSEDES: ①



Pre-printed Individual Cartons and Bags:

Date coding on pre-printed cartons and bags is governed by the location noted and defined by individual SKU's artwork / Graphics. Date code mark is to be applied by needle punching, inkjet or ink stamp in specified area. Minimum acceptable character height for pre-printed carton and bag date code shall be .13 inches [3.3 mm].



Figure 6 – Pre-printed Bag



ASSEMBLY AND TEST INSTRUCTION

Applicable Products:

All Watts purchased and manufactured products containing a UPC barcode and individual components as specified on production drawings or purchasing specifications.

ATI No. M.71.D

REV.: 1

EDP NO. 5001994

PAGE: 10 OF 11

SUPERSEDES: ①

Individual or Multi Pack – Plain (non pre-printed) Bags:

Plain individual or bulk pack bag refers to a plastic bag with no Watts graphics applied.

Date code on the bags to be applied by needle punching, inkjet, ink stamp or permanent label in an area that does not interfere with heat-sealing of the bag and is visible on both sides of the bag. Minimum acceptable character height for plain bag date code shall be .13 inches [3.3 mm].



Crated Product:

Crated packaging applies to wood or other structural packaging utilized for large or heavy items requiring reinforced packaging. Date code is to be applied to item label applied near label by stamp or stencil. Minimum acceptable character height for date applied on crate shall be .39" [10 mm].

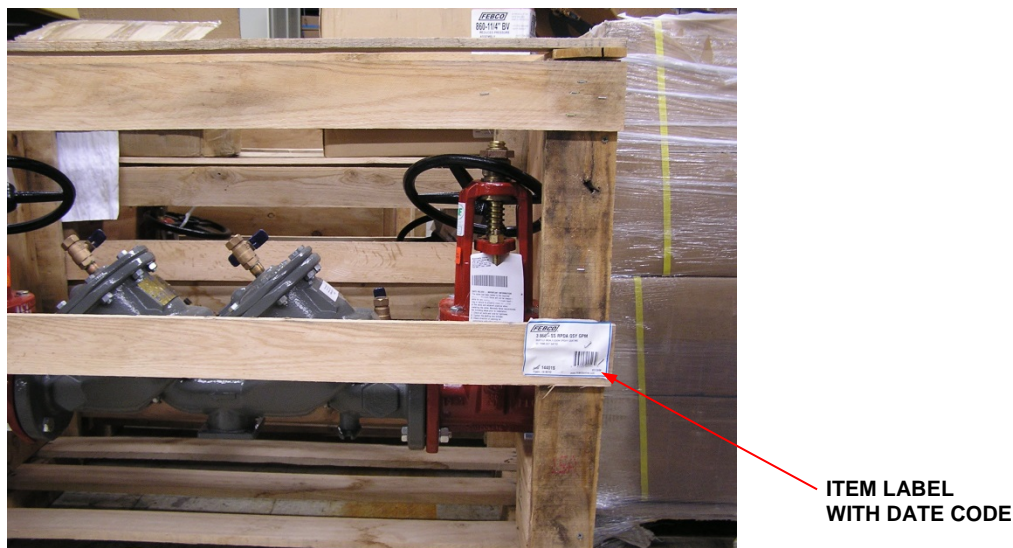



ASSEMBLY AND TEST INSTRUCTION

Applicable Products:

All Watts purchased and manufactured products containing a UPC barcode and individual components as specified on production drawings or purchasing specifications.

ATI No. M.71.D

REV.: 1

EDP NO. 5001994

PAGE: 11 OF 11

SUPERSEDES: ①

Components:

This applies to product supplied in bulk packaging that does not have specified marking requirements. Date code is applied via stamp or stencil or printed directly on label used for item identification as required by Watts purchasing specifications. Minimum acceptable character height for date code shall be .25" [6.4 mm].