

# Installation Guidelines

## Watts WaterPEX®

**⚠ WARNING**

 **Read this Manual BEFORE using this equipment. Failure to read and follow all safety and use information can result in death, serious personal injury, property damage, or damage to the equipment. Keep this Manual for future reference.**

**THINK SAFETY FIRST**

## Introduction

The purpose of this handbook is to familiarize building professionals with recommended methods of installing potable water systems using WaterPEX® tubing and CrimpRing™ fittings. All installations should be made by licensed professionals in the field, and only after carefully reviewing all the design parameters of each project.

Any questions not answered by this handbook should be referred to Watts WaterPEX® or its sales representatives; or you may wish to review Watts' other design publications for more detailed information.

Read the entire contents of this handbook before beginning the installation. If you are unsure about a matter related to WaterPEX® installation, or need additional assistance, please call us at 978-688-1811 before proceeding further.

**Installer Tips:** Throughout this manual installers share their experience and tips on the most efficient methods of installing WaterPEX®. These tips are displayed in boxes like this.

## What is WaterPEX®?

WaterPEX® is a family of quality cross-linked polyethylene pipes designed for use by professional plumbers for potable applications. It is available in  $\frac{3}{8}$ ",  $\frac{1}{2}$ ",  $\frac{3}{4}$ ", and 1" (10, 15, 20, 25mm) ID sizes in coils ranging from 100' to 1000' in length, and in 20' straight sticks. It must not be used for transporting petroleum products, natural gas, propane, anhydrous ammonia, or any other fluids. With proper precautions, and if installed in compliance with all recommendations, WaterPEX® may also be used in certain types of floor heating or snow melting systems.

## Standards and Approvals

WaterPEX® is manufactured in accordance with American Standard Testing Methods F-876 and F-877 to SDR-9 dimensional standards. It is listed by the National Sanitation Foundation NSF-61 for use in potable water systems. WaterPEX® is also listed by the International Conference of Building Officials (ICBO), the International Association of Plumbing and Mechanical Officials (IAPMO) and carries the Uniform Plumbing Code symbol. WaterPEX® is tested and certified to the Canadian Standard Association (CSA) standard B137.5. WaterPEX® fittings and pipe are not compatible with polybutylene pipe or with other cross-linked pipes and fittings not made to this SDR-9 standard.



## CrimpRing™ Connection System

WaterPEX® pipe can be joined to system components using the CrimpRing™ system, which is manufactured to the SDR-9 standard. The WaterPEX® CrimpRing™ system is the simplest and safest plumbing connection system available.

## CrimpRing™ Fittings Offer:

**The Dry-fit Advantage.** "Rough in" the entire system, check it out for fit and appearance, then crimp each connection for permanence.

**Quick and Reliable Connections.** CrimpRing™ connections are NSF-listed brass inserts with pure copper fastening rings. When crimped with a simple hand tool, these connections form a fast, reliable, and permanent seal.

**Immediate Pressure Testing.** After crimping, you can immediately test each fitting to well over 100psi (6.9 bar). There is no need to wait hours for connections to set and seal.

## Making a Good CrimpRing™ Connection

1. Cut the pipe to length, making sure that you have a good square cut. A rough, jagged, or uneven cut will result in a weakened joint.
2. Next slide the correctly sized CrimpRing™ over the end of the pipe and down about 2".
3. Then slide the pipe over the fitting until the pipe touches the fitting shoulder.
4. Now slide the CrimpRing™ over the end of the pipe until it is 1/8" to 1/4" from the end of the pipe. This positions the ring so that it is directly over the two ribs closest to the end of the fitting.
5. Now position the tool so that it is at a 90° angle to the pipe, and its jaws completely cover the ring.
6. Close the jaws completely.
7. Check to see that the "Go" slot of the Go/No-Go gauge slides across the CrimpRing™. If the CrimpRing™ doesn't fit through the "Go" slot then the ring wasn't compressed sufficiently. Cut out the joint, calibrate the tool, and make a new connection.

**Installer Tip 1.** Try a slight squeeze of the CrimpRing™ with the channel-lock pliers to keep it in place. Then you use your crimp tool to make the final connection. You'll find this especially helpful in vertical installations.

## Using a CrimpRing™ Tool Correctly

For the crimp tool to work correctly it must evenly compress the copper CrimpRing™ so that the WaterPEX® material is evenly forced between the ribs of the fitting. If the ring is not evenly compressed, the joint could leak. For that reason the tool must be correctly adjusted (see following section) and used correctly. On every joint you must ensure that the tool's jaws are located squarely over the CrimpRing™, and that the tool is positioned at a 90° angle to the fitting.

## Using a Cutting Tool and Maintaining Your CrimpRing™ Tools

A quality cutting tool helps ensure quality joints. A good square connection is essential to making good joints. If the pipe is not cut square you won't have enough material to ensure good coverage over the fitting ribs.

The CrimpRing™ tools furnished for use with WaterPEX® are quality precision instruments. They must, like all quality instruments, be kept in good adjustment to work properly. Before beginning work on each job we suggest you make a test crimp to ensure that your crimping tool has not been "knocked out" of adjustment while traveling in your truck. Don't adjust the tool unless your points begin failing the "gauge" test. However, if your crimps begin failing the test, the tool can be adjusted to compensate for wear. There are currently four types of CrimpRing™ tools available: CrimpMaster™, RingMaster™, Dual Crimper™, and REMS™ crimper. Each tool has specific guidelines for maintenance included with the tool. Follow these guidelines carefully.

**Installer Tip 2.** The best thing about the CrimpRing™ system is that you don't have to make final connections as you go along. You can wait until you know everything is just right, then go around with your crimp tool making the final connections.

Illustration of a Good CrimpRing™ Connection

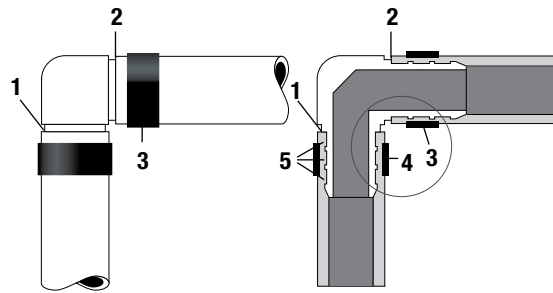

1. Fitting Shoulder location.
2. Pipe is cut square and stops at the fitting shoulder.
3. CrimpRing™ is positioned 1/8"-1/4" from end of the pipe, directly over two end ribs of fitting.
4. CrimpRing™ is evenly compressed over the pipe, and shows no evidence of uneven distortion.
5. The WaterPEX material is uniformly compressed between the brass ribs, resulting in a leak-free, quality joint.

## Using a CrimpRing™ Gauge

Using the CrimpRing™ Gauge (Go/No-Go gauge) helps ensure a quality joint. It has six openings, two for each size of pipe it fits. These are for 3/8", 1/2", and 3/4" (10, 15, 20mm) pipe sizes. See the following illustrations for guidance on how to use this important tool. Always check every joint you make.

How to Test a CrimpRing™ Connection

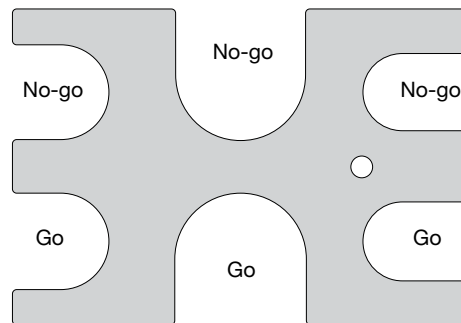

Crimp Gauge

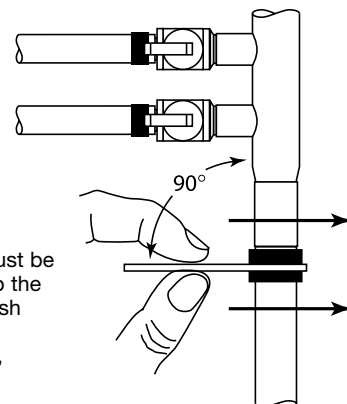

Crimp gauge must be at a 90° angle to the CrimpRing™. Push the gauge onto the CrimpRing™, do not slide it.

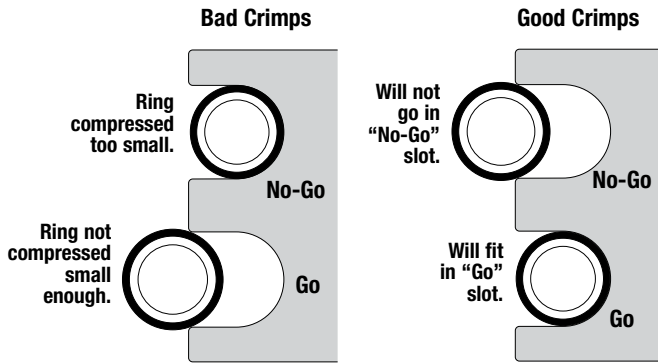

1. Check each connection by pushing the crimp gauge onto the crimped copper ring at the appropriate "Go" slot. If it won't fit through, the ring wasn't compressed enough. If the ring fits through the "No-Go" slot, the ring was compressed too much. If your connection fails this test, cut out the bad joint and start over. **Don't try to run it through the crimp tool a second time.** If the gauge "hangs up" where the tool jaws closed (you'll see a small mark there), test the joint at a different point before you fail the connection and make the connection over.
2. You must hold the gauge at a 90° angle to the ring to perform a good test.
3. Always check to make sure you're using the right size opening in the gauge for the size pipe you're installing.
4. Push the gauge right onto the crimped ring; don't slide it!
5. Don't change the gauge opening. It is manufactured to 0.002 tolerance to help protect your good reputation. Buy a new gauge if your old one is damaged.

## Installation Precautions

### Do Not Use Incompatible (Non-SDR-9) Pipe and Fittings

There are a few incompatible types of pipe and fittings that look similar to SDR-9 materials, but are made to slightly different dimensions. All compatible PEX pipe will be labeled as meeting the ASTM 876/877 Standard.

**Polybutylene pipe and fittings.** The same crimp tools used for SDR-9 WaterPEX® were also used on the older polybutylene pipe, but the fittings and CrimpRings™ are not compatible. Note that the SDR-9 WaterPEX® CrimpRings™ are colored black so that you can avoid cross-contaminating your parts bins with older polybutylene fittings.

**Installer Tip 3.** One of my guys used to keep a magic marker in his tool belt. After he crimped a ring on a fitting he would mark a line across the ring and pipe to keep track of what he'd done.

## Avoid These Common CrimpRing™ Problems

(A) The CrimpRing™ was slid past the end of the tube. When the ring was compressed it did not have enough pipe to "squeeze down on." Remember to keep the ring 1/8" to 1/4" from the end of the tube.

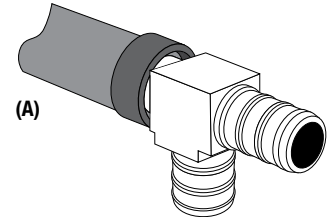

(B) The crimping tool was not held at a 90° angle to the pipe when the ring was compressed. The pipe was not evenly compressed onto the ribs.

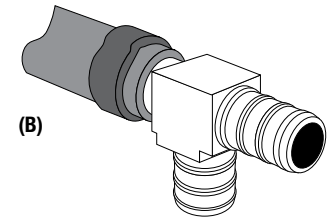

(C) The crimping tool was not centered over the CrimpRing™. The CrimpRing™ is distorted and the joint is of uneven quality.

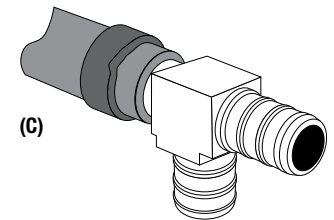

(D) The tube was not cut evenly. The pipe must cover all three ribs of the fitting.

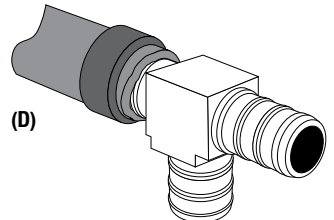

(E) The CrimpRing™ was not slid over the tube far enough to center the ring over the fitting.

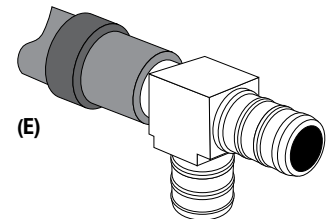

**European PEX pipe and fittings.** Most PEX pipe made in Europe, unless specifically stated otherwise, is not made to the SDR-9 standard. It may look the same, but do not use these materials with SDR-9 pipe and fittings. Some older PEX pipe made in North America was also made to this European dimensional standard. Be careful not to mix the two types.

## Protect from Physical Damage

Although WaterPEX® pipe is, in many respects, a durable material, it must be stored, installed, and protected properly to ensure a quality job. Do not use WaterPEX® to convey natural gas, propane, fuel oil, or any other hazardous or volatile fluids. Do not use WaterPEX® as an electrical ground. Following are some key points to always keep in mind.

**Installer Tip 4.** When we ran plastic pipe through mechanical chases, we were very careful to fasten the pipe away from the ductwork. It prevents abrasion and lessens the noise of expansion and contraction.

## Select the Correct WaterPEX® Size

While selecting the correct pipe size for a plumbing system, consider the following:

1. Local codes, customs, and accepted practices.
2. The volume of water required by each fixture.
3. The length of pipe required to service each fixture.
4. The vertical elevation change from the water source to the fixture.
5. The available water pressure at the water source. For most residential applications, ¾" (20mm) WaterPEX® is used for main supply lines — occasionally 1" WaterPEX® will be installed in larger homes and businesses. Generally, ⅜" or ½" (10 – 15mm) WaterPEX® is installed for branching off the main line to the various fixtures. This is the best method if installing a “conventional” system (see WaterPEX® Potable Water System Design).

If installing a “manifold” system, either ⅜" or ½" (10 or 15mm) WaterPEX® is installed. There are many advantages of the manifold system (see WaterPEX® Potable Water System Design). Using ⅜" (10mm) in lieu of ½" (15mm) offers a few additional advantages:

- Less water in the line means hot water reaches the fixture faster.
- Less water in the line means less cool water is wasted getting hot water to the fixture. Charts describing pressure drop values for various tubing diameters can be found at the end of this manual.

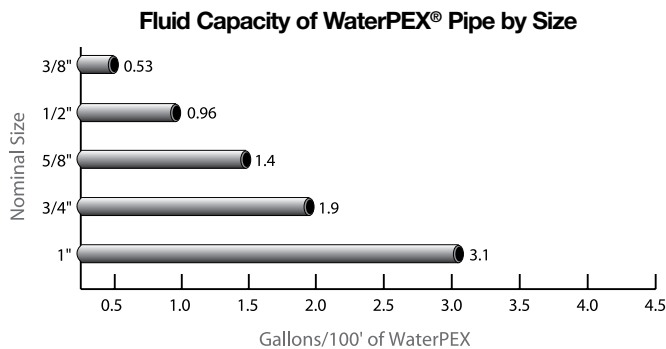

## Do Not Exceed the Minimum Bend Radius

The minimum bend radius for WaterPEX® pipe is eight times the outside diameter of the pipe. Depending on the temperature of the pipe, whether it is being rolled with or against the curvature of the roll, and the speed at which the bend is made, this number may be somewhat more. Use WaterPEX® bend supports to hold a bend at the correct radius and to hold the pipe in place (see the WaterPEX® Catalog). If you kink the pipe you may be able to reform it. Later in this manual you'll see a section that outlines how to reform WaterPEX® tubing if it is kinked.

**Installer Tip 5.** When we installed frost-free hydrant, we left some extra pipe in a loop so the hydrant could be replaced at a later date without disturbing the sheet rock. Be sure to leave enough so the reconnect won't crimp the pipe. We also wanted the hydrant well secured to the siding to prevent twisting the crimp connection.

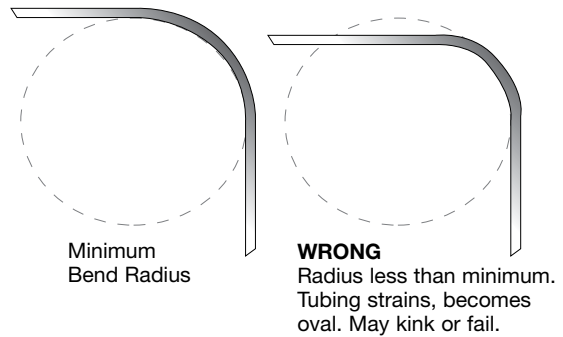

## Support Properly

Although WaterPEX® is strong, it must be supported against undue stress, strain, and thermal expansion and contraction. We suggest the following guidelines when using WaterPEX® for potable water supply lines.

Most codes require the use of approved fastening devices. It is very important that plastic fasteners are used for mounting to wood members studs, joists or plywood.

Use special stand-off type fastener like WaterPEX® StrapDowns™, and SnapClips™ (shown below). Use these for mounting to steel framing members, as well.

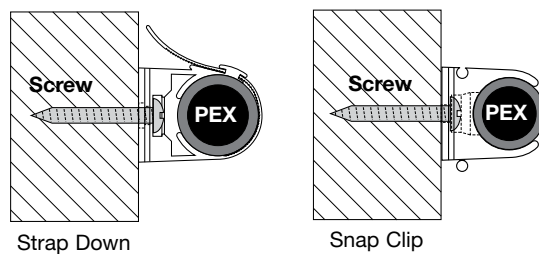

## Support horizontal and vertical runs every 30".

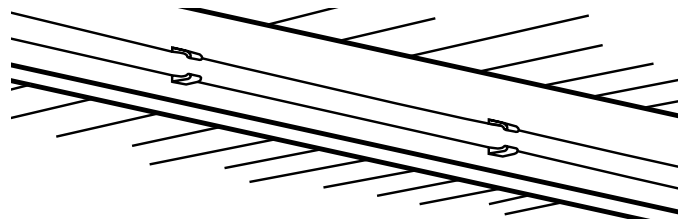

**Vertical Runs.** Vertical runs must be supported at least at every floor level. We recommend every 30"

**Horizontal Runs.** Where the pipe is fastened to the side of floor joists it should be supported every 30". If it is continuously supported the pipe can be strapped down every 6'.

## Label During Installation

While the tubing is being run to the fixture, label the tubing at both ends to designate the fixture.

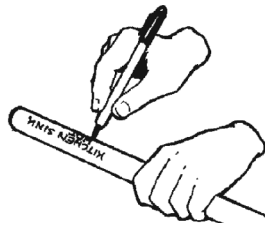

## Expansion Loops

WaterPEX® tubing expands at a rate of 1.1" per 100' of pipe for every 10°F (6°C) temperature drop. A line at an ambient temperature of 60°F (16°C) that has water at 160°F (71°C) entering it will expand 11" in a 100' run. And as that pipe cools down from 160°F to 60°F (71°-16°C) it will shrink 11". A good way to safely compensate for this expansion and contraction is to build in expansion loops in each circuit. When pipe heats and expands, the loop grows; but when the pipe cools and contracts, the loop shrinks.

Always make sure that the loops have adequate space to expand and contract. Don't install the expansion loops so that the loop is touching both joists in the floor framing, or both studs in a framed wall.

Below are two good ways to install expansion loops. Note: Always allow some slack in all your pipe runs. Remember your pipe can contract when the building is unheated during construction, and this contraction can put unnecessary stress on your pipe connections.

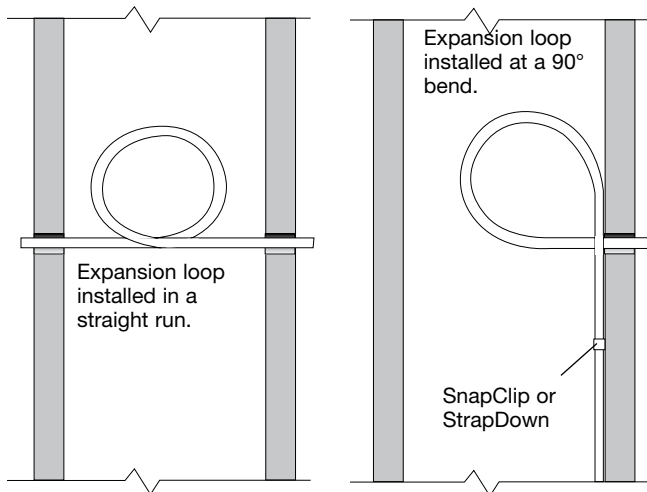

## Terminate WaterPEX® at Fixture with Care

There are several options to connect WaterPEX® distribution lines to fixtures. See our WaterPEX® System Catalog.

### NOTICE

Always leave enough excess tubing at the beginning and end of runs to make connections without putting strain on the tubing, and/or CrimpRing™ connection. DO NOT bend WaterPEX® tubing on a radius smaller than 8 times the diameter of the pipe. If bending AGAINST the coil, the allowed bending radius is 24 times the diameter of the pipe. Damaged pipe must be cut out and replaced.

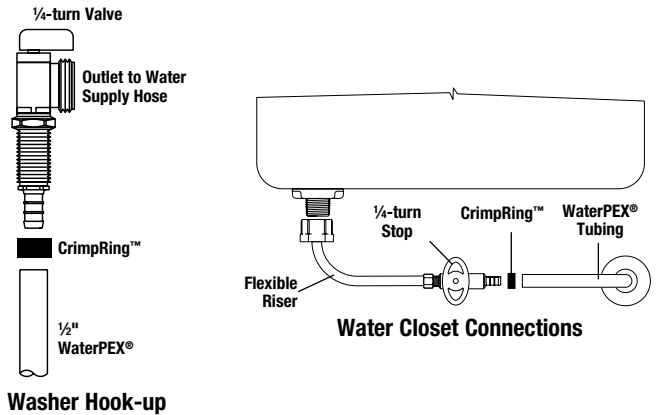
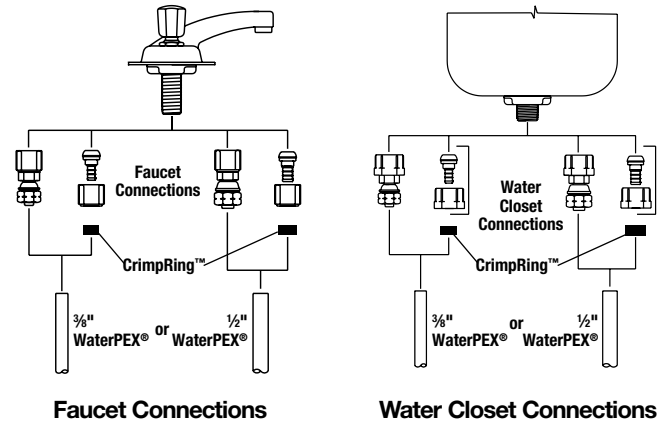

## Stubouts

To exit from a wall, you may use PEX with a bend support, or a copper stubout. If you use a stubout, be careful not to rotate the connection later when you are cutting the end off the stubout.

**Installer Tip 6.** It's a good idea to check your local code on stubouts through sheetrock or vanities to rigid copper. We've used a galvanized bracket with plastic grommets to hold and position the PEX. You can also use copper stubouts.



**Copper Stubout and Bracket**

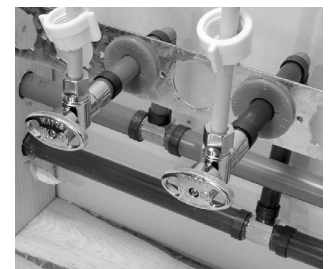

**PEX Stubouts and Bracket/Grommets**

## Trenching Precautions

Where WaterPEX® is laid in a trench, snake the pipe in with sufficient "waves" in the pipe so that there is sufficient allowance for expansion and contraction with temperature changes in the pipe.

WaterPEX® can be damaged by abrasion and by contact with abrasive materials, such as fill material with sharp edges. It is essential that the soil in the trench provide stable, continuous support for the pipe. Play it safe by installing polyethylene pipe insulation around the tubing for protection.

Always ensure that the pipe is buried such that any external load, such as the weight of the soil, or vehicular traffic does not cause the vertical dimension of the pipe to flatten by more than 5%. Suggested procedure is to pressurize before backfilling to minimize flattening of the pipe. All installation should be in compliance with local codes.

Additional information on trenching and pipe embedment practices can be obtained from ASTM D2774, Standard Recommended Practice for Underground Installation of Thermoplastic Pressure Piping, or the American Water Works Association (AWWA) report TR31, Underground Installation of Polyolefin Piping.

**Installer Tip 7.** In Salt Lake City and county we had quite a controversy around pressure testing plastic pipe. The inspectors required an air test at 150 to 175psi (10.3 to 12.1 bar). I would have to admit, in a lot of ways it made sense. I have seen uncrimped joints hold 85psi (5.9 bar) air tests, then fail when hot water hit the joints — obviously no good for anyone.

However, most plumbers don't carry compressors that go to 150psi (10.3 bar). To do the test, we had to carry nitrogen tanks (we used them for sprinkler system tests anyway). Also, some of the plumbers argued that a test at this pressure would void the manufacturer's warranty, rated at 100psi (6.9 bar).

In fact that's not the case. The rating is for pressure and temperature (180°F (82°C)). I don't think any of the fitting or pipe manufacturers have a problem with the test limit. However, we felt a hydrostatic test was best for us when the conditions allowed. It's a lot easier to locate a water leak anyway, and a missed crimp fitting won't be blown when the water hits it.

## Protect WaterPEX® Tubing at Expansion Joints

If WaterPEX® tubing is installed under expansion joints, the piping must be either sleeved with a protective layer of insulation; or the piping must dip under the slab into the underlying base material.

## Avoid Excessive Pressure and Temperature

WaterPEX® is rated up to 160psi (11 bar) at 73°F, (23°C) 100psi (6.9 bar) at 180°F (82°C), or 80psi (552 kPa) at 200°F (93°C). Make sure you don't exceed these temperature and pressure ratings. Exceeding rated temperature or pressure will void the warranty.

## Avoid Bundling Hot and Cold Lines Together

Even though WaterPEX® has much better insulating values than copper tubing, always run hot and cold lines in separate bundles to avoid heat transfer between hot and cold lines.

## Protect From Sharp or Abrasive Hangers

WaterPEX® can be damaged by metal hangers with sharp or abrasive edges; don't use them. Don't use hangers, staples or fastener that crush or pinch WaterPEX® pipe. Be careful when using hangers or fastener. Make sure they are not driven in too far and damage the pipe. If you are running bundles of piping, make sure that the entire bundle is supported by a common strap. Don't use a hook or hanger on just one tub to support the weight of the entire pipe bundle.

## Protect from Excessive Heat

WaterPEX® must be protected against excessive heat. Following are some typical kinds of exposure to excessive heat that you must be careful about.

## Soldering

Don't ever solder next to WaterPEX®. If you are soldering onto a WaterPEX® fitting make the solder connection first and then make the connection to the WaterPEX® second.

## Water Heaters and Boilers

Use metal tubing to transition between water heaters and WaterPEX®. Maintain a minimum of 18" separation between the WaterPEX® and water heaters/gas boilers.

## Recessed Light Fixtures

Maintain at least 12" (300mm) of separation between all recessed light fixtures and WaterPEX® tubing.

## Gas Appliance Vents

Maintain at least 6" (150mm) of separation between WaterPEX® and all gas appliance vents. Maintain at least 18" (450mm) of separation between WaterPEX® and wood appliance vents.

## Protect from Chemicals

**Chlorine:** Except for short-term superchlorination of potable water lines when a potable water system is being cleaned, do not permit prolonged exposure of free chlorine concentrations in excess of 2 parts per million.

## Standards for Disinfecting Water Mains

Disinfect potable water installations in accordance with the American Water Works Association C651-86, Standard For Disinfecting Water Mains, or follow local codes.

## Leak-Testing Agents

Certain kinds of chemicals found in liquid-based leak detectors, especially those containing soap, can cause long term damage to PEX and other types of plastic pipes. The same chemicals used to "lift" dirt from soiled clothes can cause microfracturing of PEX pipe and lead to its eventual failure.

## Adhesive Tape

WaterPEX® can also be damaged by some of the adhesives found in adhesive tape. Unless an adhesive tape or label is supplied by a PEX manufacturer do not apply adhesive tape to any PEX.

## Pipe Dope, Threading Compound, Mineral or Linseed Oil

WaterPEX® is damaged by some of the materials found in pipe dope, mineral oil, putty, cutting oil, and similar compounds. Do not expose WaterPEX® to these materials.

## Petroleum Products

WaterPEX® is damaged by petroleum products, such as gasoline, diesel fuel, cutting oil, brake and transmission fluids, and others. Do not expose WaterPEX® to these materials. Do not bury WaterPEX® in soil that is contaminated with these materials

## Protect Against Freezing

While WaterPEX® is resistant to freeze damage, we recommend that all plumbing systems be protected from freezing in a manner typical of the area. WaterPEX® cannot prevent damage to conventional plumbing materials if the system freezes. WaterPEX® fittings and field connections can be damaged if a plumbing system is allowed to freeze.

# Handling and Care of WaterPEX®

## Storage of Pipe

Reasonable care and protection must be taken to protect WaterPEX® from damage, both before and during the construction process.

## Temperature Range

Caution should be exercised when installing WaterPEX® at temperatures below freezing. The pipe is more easily damaged and kinked when installed at these temperatures. Best results are observed when the pipe is installed at temperatures above 50°F (10.0°C). In very cold weather you may wish to warm the pipe up in a heated room or truck cab before installing it. WaterPEX® is most flexible when installed at temperatures above 50°F (10°C).

## Reforming Kinked Pipe

1. Gently straighten the kinked WaterPEX®.
2. Using an electric heating gun, gently heat the kinked area using a sweeping motion of the heat gun that is parallel to the kink, and perpendicular to the pipe. **Never use any type of open flame.**
3. Maintain at least 1" (25mm) of distance between the end of the gun and the surface of the pipe. Do not hold the nose of the heat gun against the pipe or allow the nose of the heat gun to come in contact with the pipe.
4. Do not over heat the kinked area in an attempt to speed up the process. The surface temperature should not exceed 265°F (129°C). The hot air from the gun should not exceed 350°F. (176°C) If the gun you are using is rated at a higher temperature, hold it back further from the pipe.
5. Within a minute of heating, the tubing should gradually begin to straighten and return to its original shape. Any small creases in the kink should begin to fade.
6. As soon as the pipe returns to a generally round shape and the kink has smoothed out, stop heating it. The pipe should not be discolored.
7. Do not disturb the pipe until it cools down to room temperature.
8. Before burying the pipe it must be pressure tested.

## Thawing Frozen Pipes

WaterPEX® pipe is somewhat resistant to freeze damage, but can be damaged by excessive heat. For that reason please follow these precautions when thawing frozen pipes. Do not attempt to send electrical currents through the pipe to melt the ice. Do not apply a torch to the pipe's exterior. You can use hot air guns, as long as the temperature of the air does not exceed 300°F (149°C). Do not apply heat from hot air guns for more than five minutes at a time to one spot on the pipe. Do not heat the pipe to the point where it begins to change color.

## Splicing Damaged Pipe

If at all possible, don't make splices in inaccessible locations, such as under slab floors, or behind dry wall. If it is necessary to make buried splices, wrap the field coupling with insulation to protect the metal components against possible corrosion and mechanical stress. Pressure test splices before burying. Use only genuine WaterPEX® field repair kits when making these field splices. Never use any hose fittings/clamps or non-WaterPEX® fittings/clamps when making splices or connections.

## Sunlight Exposure

Do not expose WaterPEX® to more than 30 days of direct sunlight. It will damage the pipe and it will void the warranty.

# WaterPEX® Potable Water System Design

There are two basic ways to plumb a building: the conventional plumbing method, and the manifold home-run method.

## Conventional Plumbing Method

The conventional (or branch) method for plumbing uses one main trunk line to deliver water to various fixtures. Smaller fixtures or branch lines feed from the main line to each fixture. This main line can feed a single bathroom, or even an entire floor. However, long waits for hot water often result.

Conventional (or Branch) Plumbing Method

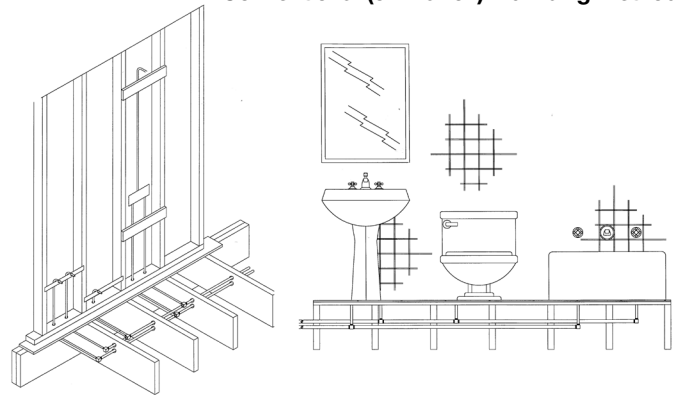

## Manifold Home-Run Plumbing Method

Manifolds add value to the house, and represent a more modern way of plumbing a house. With the manifold home-run method, fixtures are served from a central distribution point (or points), similar to electricity from a breaker box. Manifolds are useful for isolating fixtures without shutting off service to nearby fixtures, and they help ensure adequate supplies to each fixture at all times. Manifolds may be installed either horizontally or vertically. There are several advantages to the home-run method:

1. Centralized water control
2. Balanced water flow
3. Faster hot water delivery
4. Individual control to each fixture
5. Fewer fittings and connections

Manifold Home-Run Plumbing Method

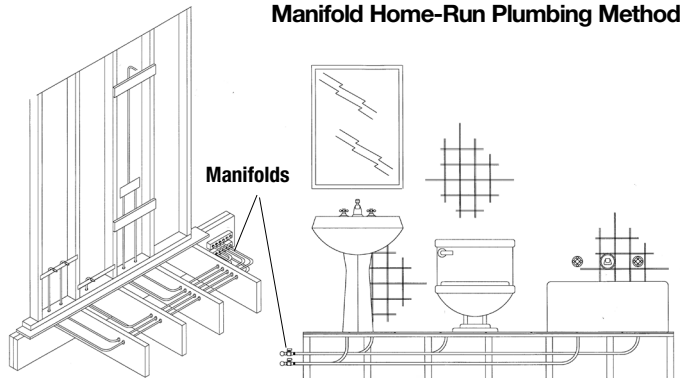

## WaterPEX® Manifold Types

Watts supplies several types of manifolds for potable water systems: Flow-through, Closed x Swedged, Closed x Crimp, and CustomCut.



Flow-Through Manifolds (4-12 branches)



Closed x Swedged Manifolds (4-12 branches)

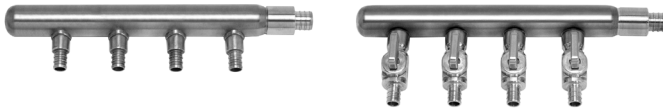

Closed x Crimp Manifolds (4-12 branches)



Custom Cut Manifolds (12 and 16 branches)

## Field Assembled Manifolds with WaterPEX® Parts

Manifolds may be field assembled using WaterPEX® factory parts and copper tees. Consult the WaterPEX® System Catalog for availability and pricing.

## WaterPEX® Manifold Connection

Manifolds may be installed in either a "terminal" or "flow-through" manner (see **A** and **B** in illustration below). A flow-through installation may have two units installed next to each other, as illustrated in **B**, or the two units may be separated by up to 100' of  $\frac{3}{4}$ " (20mm) WaterPEX® as shown in **C**. In **C**, for example, you might have one manifold servicing a kitchen, and another manifold servicing a remote bath.

Manifolds are made with either  $\frac{3}{8}$ " (10mm) or  $\frac{1}{2}$ " (15mm) CrimpRing™ fittings for use with either  $\frac{3}{8}$ " (10mm) or  $\frac{1}{2}$ " (15mm) WaterPEX®. See "Selecting the Correct WaterPEX® Size" to decide which size(s) to use for the application.

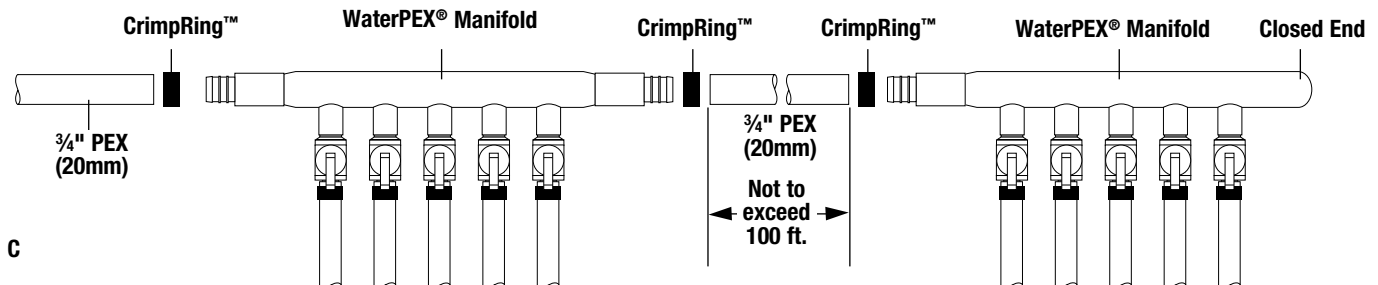
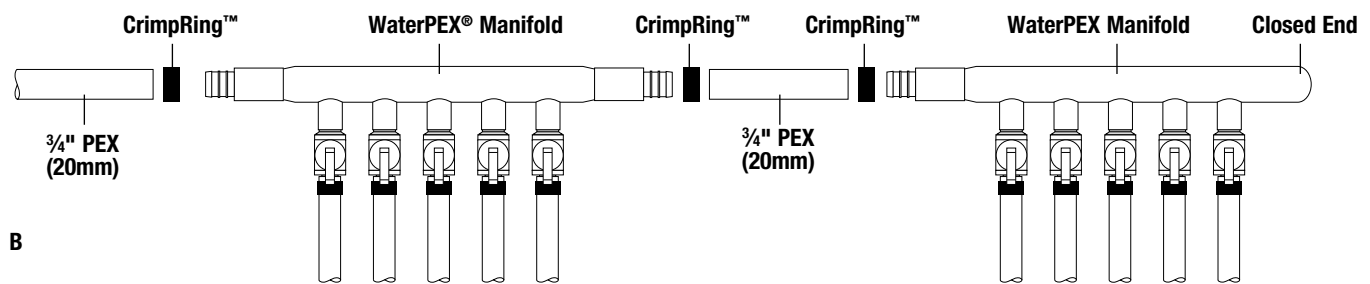
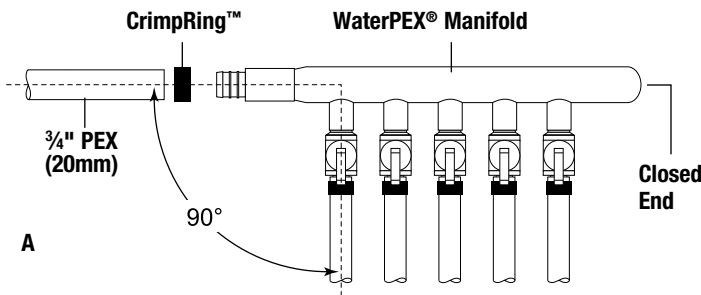

## Manifold Enclosures

Manifolds may be enclosed using various types of enclosures and panel doors from your local wholesaler. Always ensure that the manifolds will be easily accessible for future service requirements.

## WaterPEX® Manifold Precautions

- Leave the manifold in the original shipping carton until time of installation. Protect the manifold from debris, wood chips, drywall mud or dust, paint, sand, etc., before, during and after installation. The WaterPEX® manifold must be covered during application of interior finishing materials such as paints, stains and textured coatings.
- Do not subject the manifold to impact.
- Install the manifold in an accessible location where it will not be exposed to freezing temperatures.
- DO NOT allow fluids to freeze in the manifold.
- DO NOT use pipe dope or Teflon® paste to seal any fittings on the manifold.
- All supply connections to fixtures shall be made only with WaterPEX® CrimpRing™ fittings and rings.
- Supply and distribution lines shall enter or exit the manifold in a straight line parallel to the length of the manifold. Use WaterPEX® SnapClips, StrapDowns, or similar plastic tubing fastener to hold WaterPEX® securely and to prevent stress at the CrimpRing™ connection.
- Where the water contains residual free chlorine levels that routinely exceed recognized norms, the expected performance of plumbing systems components may be reduced.
- In the event of conflict or inconsistency between the WaterPEX® Installation Guidelines and local building or plumbing codes, any codes applicable to parallel plumbing systems should take precedence.

## Horizontal Installation Method

### Benefits

Installing manifolds horizontally requires less pipe bending, but requires much closer tolerances in cutting the tubing while making final connections to the manifolds. In addition, a manifold of any size will require that the framing contractor “box off” a wider cavity to make room for a longer manifold.

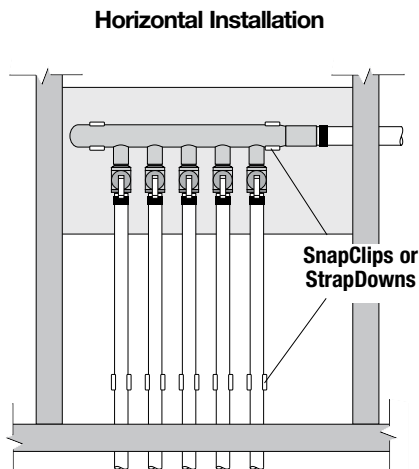

## Procedures

Snap the manifolds into the mounting brackets and hold this assembly in the manifold enclosure. Mark where the mounting brackets need to be screwed or nailed to the framing members. One-inch SnapClips work great for mounting brackets. Fasten the brackets and manifolds in place, but make sure that you have allowed room for all pipes to stay within their minimum bending radius.

## Vertical Installation Method

### Benefits

Vertical installations usually require two additional pipe bends per loop, but you have greater flexibility in positioning the pipe and manifolds. Less precision is required in cutting the piping.

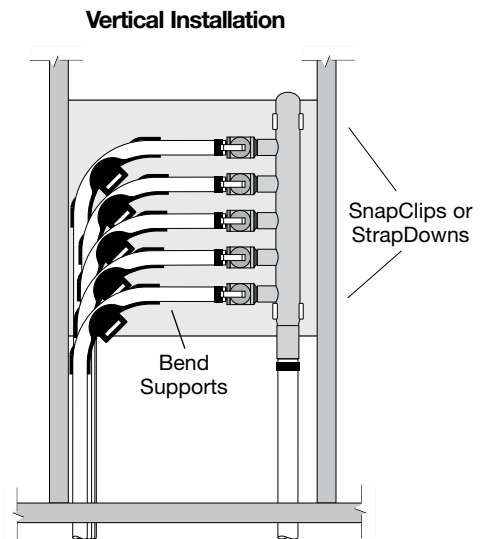

## Procedures

Snap the manifolds into the mounting brackets and hold this assembly in the manifold enclosure. Mark where the mounting brackets need to be screwed or nailed to the framing members. Fasten the brackets and manifolds in place, but make sure you have allowed room for all pipes to stay within their minimum bending radius.

## Mounting the WaterPEX® Manifold

In any installation, the manifold should not be located closer than 36" (900mm) vertically or 18" (450mm) horizontally from the water heater. The manifold must be located in an area that is not permanently covered (behind sheet-rock, plywood, paneling) or where freezing temperatures may occur.

## Supporting WaterPEX® Tubing at the Manifold

The distribution lines should exit the manifold at a 90° angle and be supported within the first 6" (150mm) of the run. See illustration below. CrimpRing™ transition fittings to adapt PEX to MPT pipe are available. Consult the WaterPEX® System Catalog for a complete listing of available connections.

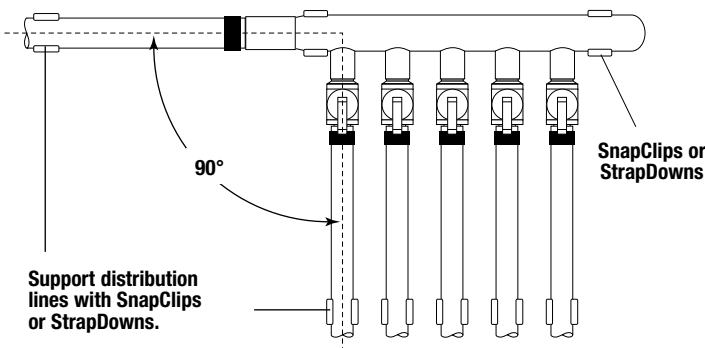

## Final System Inspection

### Inspect Before Covering the Pipe

After the WaterPEX® tubing is buried or concealed, it is a relatively permanent part of your building. Because of the difficulty in servicing buried or concealed circuits, it is essential that a final inspection be performed to ensure that the piping has not been damaged during construction, and that all circuits have been installed according to local codes and according to the building plan.

### Look for Concealed Damage

Inspect it for kinks, scrapes, slits, or crush damage. Repair or replace as good practice dictates. Ensure all manifolds are correctly located and that all tubing connections to these manifolds and fittings are tight.

### Inspect for Correct Use of fastener

As you are walking along the tubing, make sure that the tubing is properly fastened. It is essential that you maintain correct spacing between fastener.

## Pressure Test the System

Follow applicable codes before covering or concealing the tubing. In the absence of local code procedures, you must pressure test the system to between 75 (517 kPa) and 100psi (6.9 bar) for 24 hours before the tubing is to be covered. If the tubing might be damaged in construction, leave the system pressurized during the course of construction, or complete follow-up tests.

You may test with either water or air. Remember that if you pressure test with water, the system may freeze and become damaged if you forget to drain and purge all water from the system.

Depending on the air temperatures, and the pressures used, the tubing may expand slightly, or the water/air may contract over night. Either of these may cause the system pressure to show a slight drop. If you see evidence of a system pressure drop of more than 10% without evidence of a system leak, add more fluid or air. Wait another 24 hours, and check the pressure again.

## System Startup Procedures

### Fill the System

After the system is complete, it is necessary to completely fill all circuits with water. The easiest way to do this is to use line pressure to flush as much air as possible out of the piping. Open all valves and all fixtures throughout the building. Continue purging until all air is pushed out of all lines and water flows freely through all fixtures.

Call customer service if you need assistance with technical details.

### Pressure Drop at 120°F (49°C)

Flow (GPM)	3/8" (10mm) Tubing		1/2" (15mm) Tubing		3/4" (20mm) Tubing		1" (25mm) Tubing	
	Press. Drop* psi/100'	Velocity* feet per second.	Press. Drop psi/100'	Velocity feet per second.	Press. Drop psi/100'	Velocity feet per second.	Press. Drop psi/100'	Velocity feet per second.
1	6.2	3.2	1.5	1.7	<b>Water velocity too low</b>			
2	21.2	6.3	5.1	3.5	1.0	1.8	0.3	1.0
3	<b>Water velocity too high</b>		10.5	5.2	2.0	2.7	0.6	1.6
4			17.5	7.0	3.4	3.5	1.0	2.1
5	<b>Water velocity too high</b>				5.1	4.4	1.5	2.7
6					7.0	5.3	2.1	3.2
7	<b>Water velocity too high</b>				9.3	6.2	2.8	3.7
8					11.8	7.1	3.5	4.3
9	<b>Water velocity too high</b>						4.4	4.8
10							5.3	5.3

\*Rounded to the first decimal.

### Pressure Drop at 60°F (16°C)

Flow (GPM)	3/8" (10mm) Tubing		1/2" (15mm) Tubing		3/4" (20mm) Tubing		1" (25mm) Tubing	
	Press. Drop* psi/100'	Velocity* feet per second.	Press. Drop psi/100'	Velocity feet per second.	Press. Drop psi/100'	Velocity feet per second.	Press. Drop psi/100'	Velocity feet per second.
1	7.3	3.2	1.8	1.7	<b>Water velocity too low</b>			
2	24.5	6.3	5.9	3.5	1.2	1.8	0.4	1.0
3	<b>Water velocity too high</b>		12.1	5.2	2.4	2.7	0.7	1.6
4			20.1	7.0	4.0	3.5	1.2	2.1
5	<b>Water velocity too high</b>				5.7	4.4	1.8	2.7
6					8.1	5.3	2.5	3.2
7	<b>Water velocity too high</b>				10.7	6.2	3.2	3.7
8					13.5	7.1	4.1	4.3
9	<b>Water velocity too high</b>						5.0	4.8
10							6.0	5.3

\*Rounded to the first decimal.

Examples of common WaterPEX® installations for tubs, sinks, water closets, and water heaters.



Rough-in at shower using adapters, elbows, drop ear elbow, and bend supports.



Flexible PVC riser, 1/4-turn crimp x compression stop, and PEX stubout bracket.



Corrugated supply lines, full-port shut-off valves, SnapClips, and stubout bracket.



WaterPEX® riser, 1/4-turn CrimpRing™ x compression stop, and PEX stubout bracket.



WaterPEX® 1/4-turn stop, PVC riser, and copper stubout with bracket.

Examples of common WaterPEX® installations for ice makers and washing machines.



Refrigerator ice maker box with CrimpRing™ x compression 1/4-turn stop.



Dual-valve washing machine enclosure with 1/2" (15mm) CrimpRing™ fittings and flexible PVC supply lines.



Single-lever Water Off Washing Machine Control Center with 1/2" (15mm) CrimpRing™ fittings and flexible PVC supply lines.



See our WaterPEX® System Catalog for parts and supplies for the professional plumber.

- 3/8"-1" (10-25mm) WaterPEX® tubing (red, blue, white)
- Flow-through, Swedged, and Custom Cut manifolds
- CrimpRing™, sweat, and compression 1/4-turn stops
- In-line CrimpRing™ ball valves
- Adapters (male and female): crimp x sweat, crimp x NPT
- CrimpRing™ couplings and coupling kits
- Brass tees, elbows, drop-ear elbows, and test plugs
- Copper stubouts, brackets, and grommets
- Flexible risers and water heater connectors
- Tubing cutters, PEX unwinders, and crimping tools
- Fasteners, manifold brackets, and bend supports
- Washing machine valves and enclosures
- Ice maker valve and enclosure

## Limited Warranty:

A. Watts Regulator Co. ("Watts") warrants its WaterPEX® cross-linked polyethylene tubing, barbed PEX fittings, brass and plastic AquaLock™ fittings and manifolds, factory manufactured copper manifolds and AquaLock™ accessories to be free of defects in material and workmanship when used under normal usage in potable water systems, and installed in accordance with all Watts printed installation instructions. The online warranty for this product is located on Watts website (<https://www.watts.com/resources/warranty-information>) and in the event that the terms or conditions of this manual conflict with the online warranty, the terms and conditions of the online warranty shall control. Specific warranty durations apply as follows:

1. Watts WaterPEX® cross-linked polyethylene (non-barrier PEX) pipe, brass and plastic barbed PEX fittings, and factory manufactured copper manifolds when installed as a system using Watts WaterPEX pipe, Watts brass or plastic barbed PEX fittings, and Watts factory manufactured copper manifolds for a period of twenty-five (25) years from the date of original shipment.
2. Watts WaterPEX® cross-linked polyethylene (non-barrier PEX) pipe, when installed with brass or plastic barbed PEX fittings manufactured by others that meet the applicable ASTM Standards (brass - ASTM F 1807) (plastic - ASTM F 2159) for a period of ten (10) years from the date of original shipment.
3. Watts WaterPEX® brass or plastic barbed PEX fittings and factory manufactured copper manifolds when installed with cross-linked polyethylene (non-barrier PEX) pipe manufactured by others that meet the ASTM F 876 requirements for a period of ten (10) years from the date of original shipment.
4. Brass, Plastic and Mini AquaLock™ fittings and manifolds for a period of twenty-five (25) years from the date of original shipment.
5. All other valves and accessories sold under the Watts WaterPEX or Watts AquaLock™ brand name for a period of two (2) years from the date of original shipment. Watts's obligation will be to repair or replace, at its discretion, any of these products proven to be defective in material or workmanship when these products are covered under this limited warranty.

B. In the event of a system malfunction or leak caused by defective Watts warranted materials (and not by incorrect installation, incorrect handling procedures or by jobsite or installation damage), a reasonable pre-approved amount will be allowed for repair materials and repair labor. In the event of a leak occurring in a factory manifold, you may contact Watts for either a free replacement manifold or any parts reasonably needed to repair such a leak (freight prepaid). Note that Watts limits its warranty to its tubing, valves and accessories, fittings and manifolds. Watts does not warrant the connection on any installation, as the integrity of the connection is subject to the workmanship of the contractor/installer. The connection is the sole responsibility of the person who installs it.

C. In order to qualify for a warranty remedy under paragraph B, you must contact Watts in advance and receive a written authorization for this remedy from an authorized Watts representative. Repair materials, repair labor and freight expenses not authorized in writing in advance by Watts in this way will not be compensated.

D. To qualify for the warranty described above, you must do the following:

1. Use good construction techniques to install our materials, as specified in our current design and installation guidelines and technical notes. This must include field pressure testing our warranted materials before they are covered by concrete or otherwise made inaccessible.
2. Install Watts WaterPEX® and Watts AquaLock™ materials according to all guidelines and manuals published by Watts.
3. Install Watts WaterPEX® and Watts AquaLock™ products in a system that will not operate at temperatures or at pressures that exceed the rating printed on the tubing.
4. The Watts warranted product must be installed in compliance with local building and plumbing codes.

E. Evidence of tampering, mishandling, neglect, accidental damage, freeze damage or unauthorized repairs that cause damage to Watts's warranted products will void any warranty coverage for those particular products. All field connections are specifically excluded from the terms of this warranty.

F. Watts provides a complete plumbing system offering so that it is possible to complete an installation with Watts products. However, it is possible that other manufacturers' tubing and/or fittings may be installed in any given installation. Providing that the tubing and/or fittings are manufactured to their applicable standards, and have been certified by a recognized third-party testing agency, the Watts product in the given installation will continue to be covered under this warranty. In the event of a system malfunction or leak that has other tubing and/or fitting manufacturers' components installed within the failed system, Watts will be responsible only for proven defects in material or workmanship in the Watts products. Products manufactured by another company should be reported to that manufacturer for its warranty response.

G. Disclaimer of Warranty. **THE WARRANTY SET FORTH HEREIN IS GIVEN EXPRESSLY AND IS THE ONLY WARRANTY GIVEN BY WATTS WITH RESPECT TO THE PRODUCTS LISTED IN PARAGRAPH A. WATTS MAKES NO OTHER WARRANTIES, EXPRESS OR IMPLIED. WATTS HEREBY SPECIFICALLY DISCLAIMS ALL OTHER WARRANTIES, EXPRESS OR IMPLIED, INCLUDING BUT NOT LIMITED TO THE IMPLIED WARRANTIES OF MERCHANTABILITY AND FITNESS FOR A PARTICULAR PURPOSE.**

H. Limitation of Liability. The remedy described above shall constitute the sole and exclusive remedy for breach of warranty, and, apart from that remedy, Watts shall not be responsible for any incidental, special or consequential damages, including without limitation, lost profits or the cost of repairing or replacing other property which is damaged if these warranted products do not work properly, other costs resulting from labor charges, delays, vandalism, negligence, fouling caused by foreign material, damage from adverse water conditions, adverse chemical environments, or any other circumstances over which Watts has no control. This warranty shall be invalidated by any abuse, misuse, misapplication or improper installation of the product. Some states do not allow limitations on how long an implied warranty lasts, and some states do not allow the exclusion or limitation of incidental or consequential damages. Therefore the above limitations may not apply to you. This Limited Warranty gives you specific legal rights, and you may have other rights that vary from state to state. You should consult applicable state laws to determine your rights. **SO FAR AS IS CONSISTENT WITH APPLICABLE STATE LAW, ANY IMPLIED WARRANTIES THAT MAY NOT BE DISCLAIMED, INCLUDING THE IMPLIED WARRANTIES OF MERCHANTABILITY AND FITNESS FOR A PARTICULAR PURPOSE, ARE LIMITED IN DURATION TO ONE YEAR FROM THE DATE OF ORIGINAL SHIPMENT.**

I. RETURNED GOODS: No material shall be returned without authorization. When credit is issued it will be at the price charged, or prevailing price if lower, less handling charges based on costs of reconditioning, boxing, etc. However, a minimum 25% handling charge will apply. A minimum handling charge of 20.00 is applied whenever the 25% handling deduction does not total 20.00. Products which are obsolete or made to special order are not returnable.

NOTE: Prices and terms are subject to change without notice and supersede all previous quotations. The right is reserved to change or modify product design or construction without prior notice and without incurring and obligation to make such changes and modifications on products previously or subsequently sold.

