

PWSR Series Softeners

Installation, Operation and Maintenance Manual

⚠ WARNING



Read this Manual **BEFORE** using this equipment.

Failure to read and follow all safety and use information can result in death, serious personal injury, property damage, or damage to the equipment.



Keep this Manual for future reference.

⚠ WARNING

You are required to consult the local building and plumbing codes prior to installation. If the information in this manual is not consistent with local building or plumbing codes, the local codes should be followed. Inquire with governing authorities for additional local requirements.

⚠ WARNING

Need for Periodic Inspection/Maintenance: This product must be tested periodically in compliance with local codes, but at least once per year or more as service conditions warrant. All products must be retested once maintenance has been performed. Corrosive water conditions, and/or unauthorized adjustments or repair could render the product ineffective for the service intended. Regular checking and cleaning of the product's internal components helps assure maximum life and proper product function.

⚠ WARNING

Do not use with water that is microbiologically unsafe or of unknown quality adequate disinfection before and after the system.

NOTICE

Hydrocarbons such as Kerosene, Benzene, Gasoline, etc., may damage products that contain O-rings or plastic components. Exposure to such hydrocarbons may cause the products to leak. Do not use the product(s) contained in this document on water supplies that contain Hydrocarbons such as Kerosene, Benzene, Gasoline, etc.



PWSR Series Softeners

Table of Contents

System Specifications	2
Control Valve Functions	3
General Installation Instructions	4
Safety Information & General Warnings	4-5
Pre-Installation Considerations	5-6
Installation Preview	6
System Components Described	7
Bypass Valve Installation	8
Installation Instructions	6-10
PWSR Quick Programming Guide	11-12
Control Programming	13-14
System Components Described	14-16
Drawings and Part Numbers	17-22
System Troubleshooting	23-26
Notes	27

System Specification Table

A. Models Chart

MODEL NO.	CAPACITY (MAX.)	PIPE SIZE (IN.)	MINERAL TANK			BRINE TANK		FLOW RATE & PRESSURE			SHIP WT. (LBS.)
			TANK SIZE	RESIN FT ³	GRAVEL (LBS.)	TANK SIZE	SALT FILL	SERVICE (GPM)	DROP (PSI)	BKW (GPM)	
PWSR130	30,000	1"	9" x 48"	1	15	18" x 36"	350	9 - 12	15 - 25	2.2	110
PWSR145	45,000	1"	10" x 54"	1.5	20	18" x 36"	350	12 - 16	15 - 25	2.7	130
PWSR160	60,000	1"	12" x 52"	2	30	18" x 36"	350	15 - 20	15 - 25	3.5	190
PWSR190	90,000	1"	14" x 65"	3	60	18" x 40"	400	18 - 23	15 - 25	4.2	265

Control Valve Functions

Control Valve Function and Cycles of Operation

This glass filled Noryl fully automatic control valve is designed as the primary control center to direct and regulate all cycles of a water softener. The control valve can be set to regenerate on demand (consumption of a predetermined amount of water) and/or as a time clock (passage of a particular number of days).

The control valve is compatible with a variety of regenerants and resin cleaners. The control valve is capable of routing the flow, of water in the necessary paths to regenerate or backwash water treatment systems. The injector regulates the flow of brine or other regenerants. The control valve regulates the flow rates for backwashing rinsing and the replenishing of treated water into a regenerant tank.

The control valve is designed to deliver high service (27 gpm @ 15 psig) and backwash (27 gpm @ 25 psig) flow rates when the bypass has straight fittings. The control valve uses no traditional fasteners (e.g. screws), instead clips, threaded caps and nuts and snap type latches are used. Caps and nuts only need to be firmly hand tightened because radial seals are used. Tools required to service the valve include one small blade screwdriver, one large blade screwdriver, pliers and a pair of hands. A plastic wrench is available which eliminates the need for screw-drivers and pliers. Disassembly for servicing takes much less time than comparable products currently on the market.

The transformer power pack comes with a 15-foot power cord and is designed for use with the control valve. The transformer power pack is for dry location use only. The control valve remembers all settings for two hours if the power goes out. After two hours the only item that needs to be reset is the time of day, all other values are permanently stored in the nonvolatile memory. The control valve does not need batteries.

When the control valve is used as a down flow softener, two backwashes always occur. The softener will start regenerant prefill before regeneration, the prefill starts two hours before the regeneration time set. During the 2-hour period in which the brine is being made, treated (softened) water is still available. For example: regeneration time = 2:00 am, prefill option selected, downflow softener. Fill occurs at 12:00 a.m., start of backwash cycle occurs at 2:00 a.m.

The softener will adjust the backwash and rinse cycles automatically increase with increasing, salt dosage. Backwashes can be set to be NORMAL or LONGER. The option selected will apply to all backwashes. Tables 4 and 5 show the length of the cycles when the valve is set up as a softener.

Regeneration Steps and Purpose:

Brine fill – Brine tank is filled to dissolve salt for next regeneration.

Backwash – Flow through the resin bed is reversed. Water flows upward expanding and agitating the resin bed.

Brine in – Brine is educted from the brine tank and pass-es through the resin bed in a downward flow, thus removing calcium and magnesium that has accumulated on the resin beads and is flush to drain.

Backwash – A second backwash is performed

Rinse – The resin is now flushed downward at a set flow rate. This resettles the bed and rinses out any remaining brine left in the resin bed.

Service – Softener goes back into service and ready to soften water.

Exchange Capacity Data

20,000 grain approx. per cu. ft.

6 lbs. salt-sodium chloride

25,000 grain approx. per cu. ft.

8 lbs. salt-sodium chloride

30,000 grain approx. per cu. ft.

15 lbs. salt-sodium chloride

NOTICE

To convert parts per million (PPM) or milligrams per liter (mpl) to grains divide by 17.1

Example: Water hardness of 250 PPM

(250 PPM divided by 17.1 PPM/gr.) equals 14.6 gr.

It is recommended that a good grade of solar or pellet salt be used.

One-gallon water will dissolve approximately 3.0 lbs. of salt

One gallon of saturated brine weighs 10.74 lbs.

⚠ WARNING

General Installation Guidelines

This water conditioner's control valve conforms to UL/CE Standards. Generic valves were tested and certified for compliance as verified by the agency listing. This water conditioning system is to be used only for potable water. Inspect the water conditioning system for carrier shortage or shipping damage before beginning installation.

Operating Parameters:

- Operating ambient temperature: 40° to 110°F (5° to 43°C).
- Operating water temperature: 40° to 110°F (5° to 43°C).
- Operating water pressure range : 25 to 120 psi (1.7 to 8.27bar).

Installation Parameters: All plumbing should be done in accordance with local plumbing codes.

NOTICE

If risk of vacuum exists, install Watts # 0556031 vacuum relief valve in the inlet supply line to protect the system against vacuum damage in well applications. If the system is installed on a public water supply above the ground floor of a building install the vacuum relief valve on the outlet line to protect the system against vacuum in the event the plumbing system is drained.

- Do not use pipe dope or other sealants on threads. Use Teflon tape on the threaded inlet, outlet and drain fittings. Teflon tape is not necessary on the nut connection or caps because of o-ring seals.
- All plastic connections should be hand tightened. Teflon® tape may be used on connections that do not use an O-ring seal. Do not use pipe dope type sealants on the valve body. **Do not use pliers or pipe wrenches.**
- Observe drain line requirements.
- Keep the media tank in the upright position. Do not turn upside down or drop. Turning the tank upside down or laying the tank on its side can cause media to enter the valve.
- The pipe size for the drain line should be a minimum of ½". Backwash flow rates in excess of 7 gpm (26.5 lpm) or length in excess of 20' (6.1m) require ¾" drain line.
- Do not support the weight of the system on the control valve fittings, plumbing, or the bypass.

Environmental:

- Use only regenerants designed for water conditioning. Do not use ice melting salt, block salt or rock salt. During cold weather it is recommended that the installer warm the valve to room temperature before operating. Teflon® is a trademark of E.I. duPont de Nemours.
- Do not use petroleum-based lubricants such as Vaseline, oils or hydrocarbon-based lubricants. Use only 100% silicone lubricants.
- Do not allow this water conditioning system to freeze. Damage from freezing will void this water conditioning system's warranty.
- **HYDROCARBONS SUCH AS KEROSENE, BENZENE, GASOLINE, ETC., MAY DAMAGE PRODUCTS THAT CONTAIN O-RINGS OR PLASTIC COMPONENTS. EXPOSURE TO SUCH HYDROCARBONS MAY CAUSE THE PRODUCTS TO LEAK. DO NOT USE THE PRODUCT(S) CONTAINED IN THIS DOCUMENT ON WATER SUPPLIES THAT CONTAIN HYDROCARBONS SUCH AS KEROSENE, BENZENE, GASOLINE, ETC.**

- **THIS WATER METER SHOULD NOT BE USED AS THE PRIMARY MONITORING DEVICE FOR CRITICAL OR HEALTH EFFECT APPLICATIONS.**

- Do not use Vaseline, oils, other hydrocarbon lubricants or spray silicone anywhere. A silicone lubricant may be used on black o-rings but is not necessary.

Electrical:

- Use only the power transformer supplied with this water conditioning system.
- All electrical connections must be completed according to local codes.
- The power outlet must be grounded.
- All electrical connections must be connected according to local codes. (Be certain the outlet is uninterrupted.)
- Install grounding strap on metal pipes.
- The power adapter comes with a 15 foot power cord and is designed for use with the control valve. The power adapter is for dry location use only. The control valve remembers all settings until the battery power is depleted if the power goes out.
- After the battery power is depleted, the only item that needs to be reset is the time of day; other values are permanently stored in the nonvolatile memory. The control valve battery is not rechargeable but is replaceable.
- No user serviceable parts are on the PC board, the motor or the power adapter. The means of disconnection from the main power supply is by unplugging the power adapter from the wall.
- Install an appropriate grounding strap across the inlet and outlet piping of the water conditioning system to ensure that a proper ground is maintained.
- To disconnect power, unplug the AC adapter from its power source.

Soldering:

- Use only lead-free solder and flux, as required by federal and state codes, when installing soldered copper plumbing.
- Use caution when installing soldered metal piping near the water conditioning system. Heat can adversely affect the plastic control valve and bypass valve.
- Solder joints near the drain must be done prior to connecting the drain line flow control fitting. Leave at least 6" between the drain line control fitting and solder joints when soldering pipes that are connected on the drain line control fitting. Failure to do this could cause interior damage to the drain line flow control fitting.
- When assembling the installation fitting package (inlet and outlet), connect the fitting to the plumbing system first and then attach the nut, split ring and o-ring. Heat from soldering or solvent cements may damage the nut, split ring or o-ring. Solder joints should be cool and solvent cements should be set before installing the nut, split ring and o-ring. Avoid getting primer and solvent cement on any part of the o-rings, split rings, bypass valve or control valve.

General Warnings (continued)

⚠ WARNING

Installation Guidelines:

Control Valve:

- This glass filled Noryl¹ (or equivalent) fully automatic control valve is designed as the primary control center to direct and regulate all cycles of a water softener or filter.
- The control valve, fittings and/or bypass are designed to accommodate minor plumbing misalignments but are not designed to support the weight of a system or the plumbing.
- The nuts and caps are designed to be unscrewed or tightened by hand or with the special plastic wrench. If necessary pliers can be used to unscrew the nut or cap. Do not use a pipe wrench to tighten or loosen nuts or caps. Do not place a screwdriver in the slots on caps and/or tap with a hammer.
- After completing any valve maintenance involving the drive assembly or the drive cap assembly and pistons unplug power source jack from the printed circuit board (black wire) and plug back in or press and hold NEXT and REGEN buttons for 3 seconds. This resets the electronics and establishes the service piston position. The display should flash all wording, then flash the software version and then reset the valve to the service position.
- The control valve is compatible with a variety of regenerants and resin cleaners. The control valve is capable of routing the flow of water in the necessary paths to regenerate or backwash water treatment systems. The injector regulates the flow of brine or other regenerants. The control valve regulates the flow rates for backwashing, rinsing, and the replenishing of treated water into a regenerant tank, when applicable.
- Control valve installation is made easy because the distributor tube can be cut ½" above to ½" below the top of tank thread. The distributor tube is held in place by an o-ring seal and the control valve also has a bayonet lock feature for upper distributor baskets.

Pre-Installation Considerations

A. Water Pressure

A minimum of 25 pounds of water pressure is required for regeneration valve to operate effectively. Do not exceed maximum water pressure of 125 pounds of water pressure.

B. Electrical Facilities

A continuous 120 volt, 60 Hertz current supply is required. Make certain the current supply is always hot and cannot be turned off with another switch.

⚠ WARNING

As with any electrical product, care should be taken to guard against the potential risk of fire, electric shock, and injury to persons

C. Existing Plumbing

Condition of existing plumbing should be free from lime and iron buildup. Piping that is built up heavily with lime and/or iron should be replaced. If piping is clogged with iron, a separate iron filter unit should be installed ahead of the water softener.

D. Where to Install the Softener

Consider the following points when determining where to install the water softener:

- Place the system as close as possible to a sewer drain.
- Do not install the softener where it would block access to the waterheater, or access to the main water shutoff, water meter, or electrical panels.
- Keep outside faucets on hard water to save soft water and salt.
- Install the softener in a place where water damage is least likely to occur if a leak develops.
- A 120VAC electrical outlet is needed to plug in the transformer. If the outlet is remote (up to 100 feet), use 18 gauge wire to connect.
- Always connect the system to the main water supply pipe before the water heater.
- Install the system where it will not be subject to temperatures outside of the limits stated in the Specification section or to direct sunlight.

E. Bypass Valves

Always provide for the installation of a bypass valve.

F. Valve to Tank Installation Instructions

1. Spin the valve onto the tank, ensuring the threads are not cross-threaded.

NOTICE

The control valve have right-hand threads, or clockwise, to install

2. Rotate the valve freely without using force until it comes to a stop (this position is considered zero).
3. Rotate the valve clockwise from zero, between ¼ turn and ½ turn to fully tighten. No tools are needed. Hand tight is enough. Overtightening may cause valve or tank damage.

NOTICE

If lubricant is required, a silicone compound is strongly recommended. Dow Corning® Silicone Compound (available from Watts), is recommended for best possible results. Dow Corning® 7 Release Compound is used in the manufacture of this control valve. The use of other types of lubricants may attack the control's plastic or rubber components. Petroleum-based lubricants can cause swelling in rubber parts, including O-rings and seals.

¹Noryl is a trademark of Sabic.

Pre-Installation Considerations (continued)

G. Pre Installation and Loading of Media

Systems that are 13" in diameter and larger are not loaded with media. These systems must be loaded with media before placing into service. To load a system follow the below steps.

1. Cap the top open end of the distributor tube with tape and plastic sheeting to keep foreign debris from entering the distributor tube. This cap must be secure and not come off during media loading.
2. Place the distributor tube, screen end down, into the mineral tank and center it in the bottom. The top of the distributor tube should be flush with the top of the tank.
3. Make sure the plastic and tape cap is secure to the top of the distributor tube, place a funnel on the top of the tank and load first the gravel (if different sizes of gravel are used load the largest gravel first, then the smaller gravel) then the resin media into the tank. The cap must not come off of the distributor tube during the loading of the media.
4. Remove the plastic cap from the distributor tube. **DO NOT PULL UP ON THE DISTRIBUTOR TUBE** when removing the cap. The distributor tube top must remain flush with the top of the tank.
5. Clean any media from the threads and top of the mineral tank.
6. Lubricate the O-rings on the bottom of the control valve (distributor pilot O-ring and top of tank O-ring). Use non-petroleum based silicone lubricant only.
7. Place the control valve on top of the tank. When doing this step, seat the top of the distributor tube inside the centered O-ring sealed port on the bottom of the valve first then press the valve down until the tank threads come in contact with the valve threads. This ensures that the distributor tube is properly seated into the bottom of the control valve. Thread the valve on to the tank clockwise. Be careful not to cross thread the valve or over tighten it. A hand tight snug fit is appropriate for the control valve torque. A wrench is not necessary. Do not use thread sealant or PTFE tape on the valve base threads.
8. The system is now ready for installation. Follow the Installation Section in the Installation, Operation and Maintenance Manual.

Installation Preview

Conduct a visual check of all equipment for any damage that may have occurred during shipment.

NOTICE

If there is obvious damage to any equipment, it should be noted on the carrier's Bill Of Lading. Open and inspect the contents of all closed crates, cartons, etc. and inspect for concealed damage. The manufacturer is not liable for any damage during transit.

Position the equipment in its proper location, setting on a flat surface. Level equipment as required. Equipment out of plumb can exhibit poor flow characteristics, which will affect the performance of the system.

NOTICE

Units are shipped with media (resin & gravel), distributions tube, and control valve installed. Double-check the valve installation on the tank. Tighten if necessary.

Unit should be positioned with the valve control facing forward.

Check the main line water pressure. The softener is designed for a minimum of 20 psi and a maximum of 125 psi working pressure. If the line pressure exceeds this limit, a pressure-reducing valve should be installed.

Maximum allowable water temperature is 40°F (4°C) – 110°F (38°C). A 120vac 60 cycle electrical source must be available for operation of the controller.

Installation Preview (continued)

Connect raw water supply line to the inlet valve connection. Connect treated water outlet to service line. It is suggested that the pipe size be equal or one size larger than the valve connection.

NOTICE

Softener to be located at least 10 feet away from hot water heater to protect against hot water back-up.

⚠ WARNING

When piping with copper, solder all piping as sub-assemblies before installing. Internal damage can result from the high heat of the torch.

It is recommended that manual isolating valves be installed on the inlet and outlet piping along with a system bypass valve. This will isolate the unit when service is required. Run drain line to a sump, drain trench, or other open drain. Open drains are required for taking samples and allowing a visual check. Avoid overhead pipe runs to drain facility, as undue backpressure will affect the operation of injectors.

NOTICE

All piping is to meet your local and state code. **AVOID CROSS CONNECTIONS!**

Position brine tank approximately 6" from the softener tank on a smooth surface.

Connect the brine air check assembly in the salt/brine tank to the brine suction (eductor) connection. If brine tank is located more than 6 feet from softener tank, use one size larger tubing. Tubing 5/8" should be installed from the brine tank over-flow to drain. This is a gravity drain designed to divert brine to the drain in the event of a malfunction, which would cause overflow of the brine tank.

Be sure inlet/outlet isolating valves are closed and bypass valve is open.

⚠ WARNING

Do not exceed water pressure of 120 psi (8.2 bar). Do not exceed 110°F (43.3°C). Do not subject unit to freezing conditions.

Installation Instructions

1. Turn off water heater(s).
2. Turn off the main water supply to the home and open an inside faucet (cold and hot) to relieve any pressure within the plumbing system.

Select Location

1. Place the system in the desired installation location. Make sure that the location is level and sturdy enough to support the weight of the system once it is in operation.
2. You will need to locate the water softener at least 10 feet away from the hot water heater so that hot water does not backup and damage the softener.
3. You will need a drain close by for disposal of regenerated wastewater.
4. If installing the softener in an outside locations, make sure to protect softener from the elements, such as freezing temperatures, rain, sunlight and contamination

Install a By-Pass

NOTICE

Always install a bypass, either a 3-way valve system or the standard bypass for the valve you have. This will allow you to shut off the water supply to the softener, but still have water in the house if the softener is in need of repair.

Installation Instructions (continued)

Install a By-Pass (continued)

After a location has been determine install bypass onto the control valve. (On page 8, Figures 1 and 3 show standard bypass on valve.) (Figures 2 and 4 show 3-way by pass plumbing.)

NOTICE

If installing a 3-way bypass valve, do so now.

Close main water supply valve, at the well or at the water meter.

Shut off electrical or fuel supply to the water heater.

Open all faucets to drain pipes.

NOTICE

The bypass (provided) easily connects to the valve body using nuts that only require hand tightening. The split ring retainer design holds the nut on and allows load to be spread over the entire nut surface area reducing the chance for leakage.

Make certain the nut is placed on first, then the split retainer ring, followed by the o-ring to make the seal. A silicon lubricant may be used on the black o-ring seals. This design allows for an approximate 2-degree misalignment of the plumbing. This design will allow for minor plumbing misalignments, but should never handle the weight of the plumbing system.

System Components Described

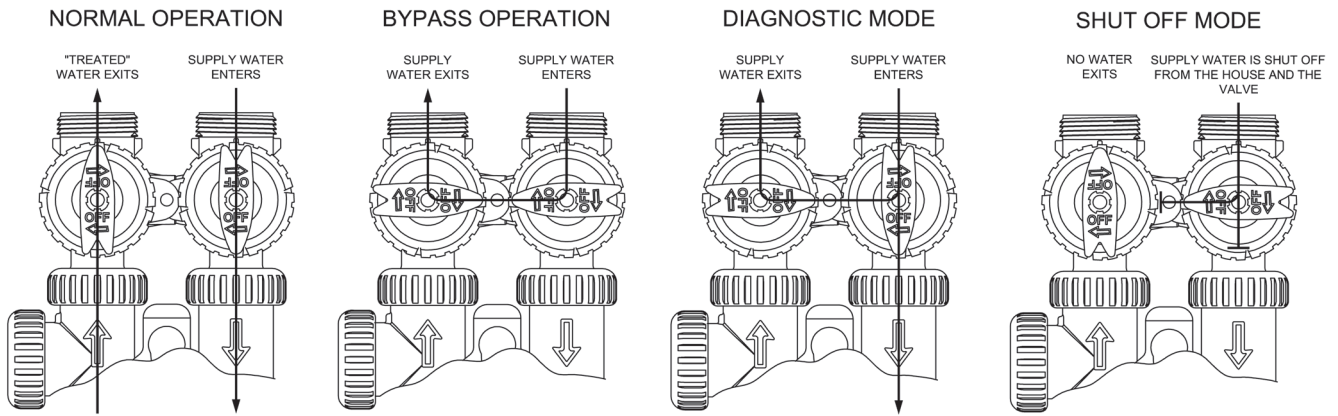

Bypass Valve Installation

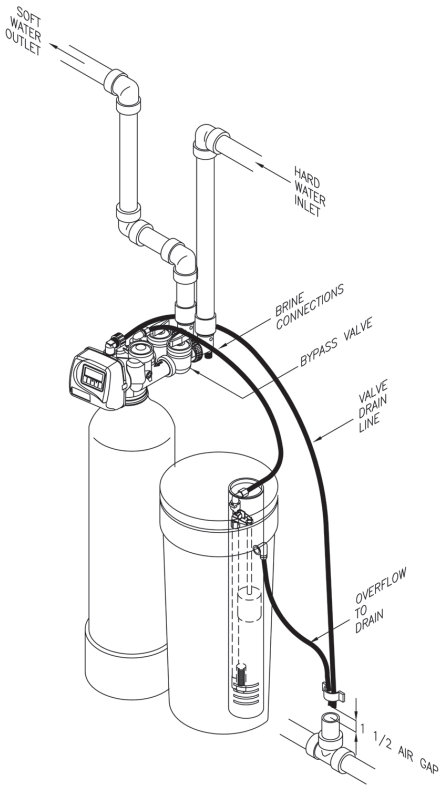

Figure 1: Plumbing with by pass (Standard).

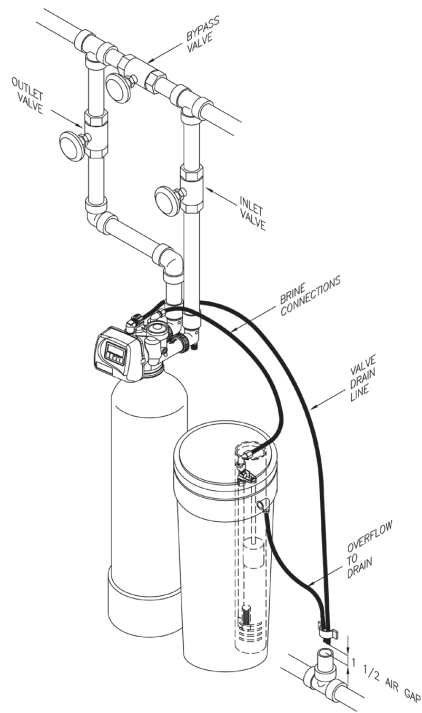

Figure 2: Plumbing with 3-way b pass.

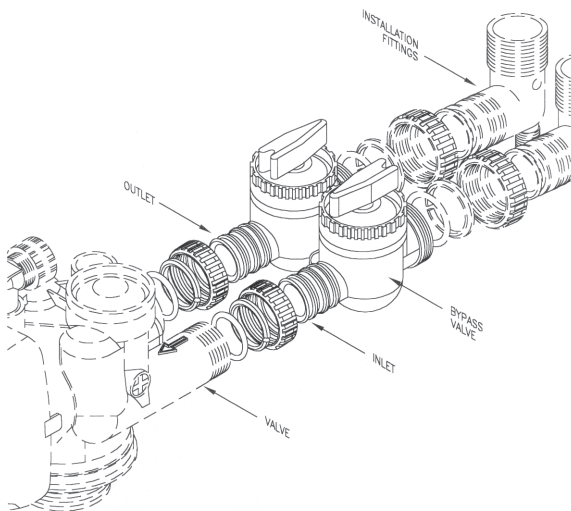

Figure 3: Bypass (standard).

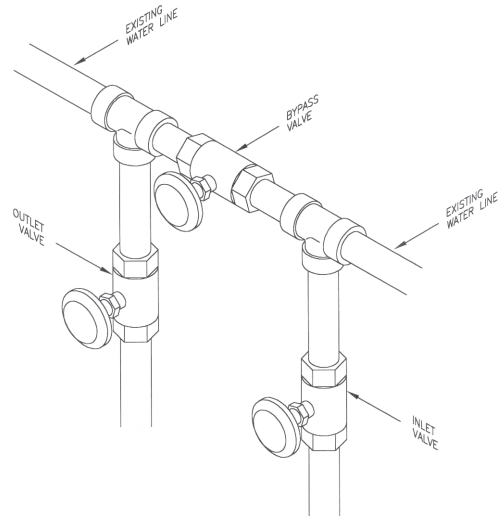

Figure 4: 3-way bypass plumbing.

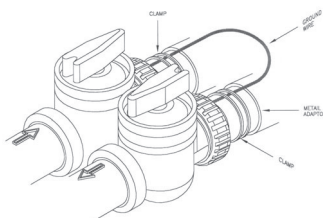

Figure 5:

When installing sweat copper follow state and federal codes by using a lead free solder and flux. Use a joint compound to seal threaded pipe. Some homes use the cold water pipes for an electrical ground (metal only). When finished with plumbing, a ground wire should be connected to the copper pipes to complete the ground circuit. Use two clamps and #4 copper for this.

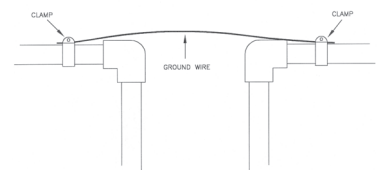

Figure 6:

Installation Instructions (continued)

Move Water Softener Into Place

1. Connect the cold water supply to the inlet of the water conditioning system. While constructing the supply line, install a master supply valve (user supplied) in the supply line and close it.
2. Connect the feed water line to the home to the outlet of the system.
3. Make sure floor is level.

Measure, cut, and install pipe and fittings to the bypass valve (dry fit only to make sure you have a proper fit) inlet and outlet side. Be sure hard water is supplied to the inlet side. Trace pipe to be sure.

The installation fittings connect to the control valve or the bypass valve using nuts that only require hand tightening. Hand tighten nut connections between control valve and installation fittings, control valve and bypass valve, and bypass valve and installation fittings allow for easy serviceability. Do not use a pipe wrench to tighten nuts on installation fittings. Hand tighten only.

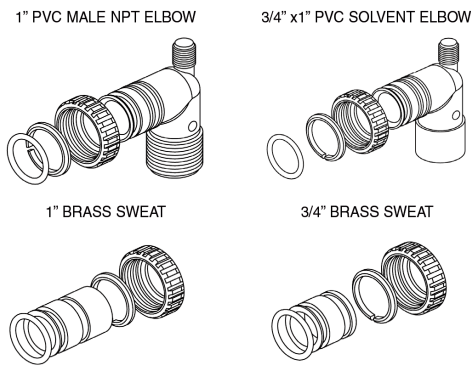
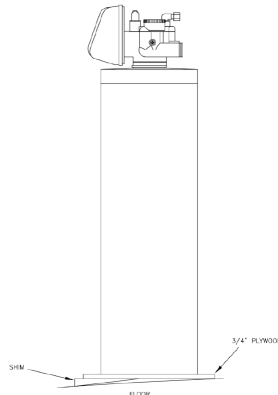

Figure 8: Four types of installation fittings.

NOTICE

When assembling the installation fitting package, connect the fitting to the plumbing system first and then attach the nut, split ring and o-ring. Heat from soldering or solvent cements may damage the nut, split ring, and o-ring. Make sure solder joints are cool before assemble is started.

Split ring retainer design holds the nut on and allows load to be spread over the entire nut surface area reducing the chance for leakage. The split ring design, incorporated into the installation fittings allows approximately 2 degrees off axis alignment to the plumbing system. The installation fittings are designed to accommodate minor plumbing misalignments but are not designed to support the weight of a system or the plumbing.

When assembling the installation-fitting package, connect the fitting to the plumbing system first and then attach the nut, split ring and o-ring. Heat from soldering or solvent cements may damage the nut, split ring, or o-ring. Solder joints should be cool and solvent cements should be set before installing the nut, split ring, and o-ring. Avoid getting primer and solvent cement on any part of the o-rings, split rings, and bypass valve or control valve. Solvent cements and primers should be used in accordance with the manufacturer's instructions.

Slip the nut onto the fitting first, then the split ring second and the o-ring last. Hand tighten the nut. If the fitting is leaking tightening the nut will not stop the leak. Remove the nut, remove the fitting, and check for damage or misalignment of the o-ring.

Do not use pipe dope or other sealant on threads. Teflon tape must be used on the threads of the 1" NPT elbow and the 1/4" NPT connection and on the threads for the drain line connection. Teflon tape is not necessary on the nut connection or caps because of o-ring seals.

Move Brine Tank Next to Softener and Connect Brine Draw Line to Valve

1. Connect the brine tank to the water softener control valve brine inlet port using the factory supplied fittings and tubing. Add enough water to the brine tank so that water covers the top of the air check. **DO NOT ADD SALT AT THIS TIME.**

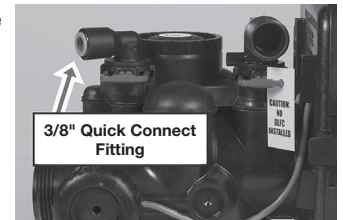

2. With brine tank next to the softener tank connect the brine draw line to valve body. Connect to valve body 3/8" Quick Connect fitting.

Control valves that use a regenerant, come equipped with a 3/8" refill flow control assembly.

Complete the connection by installing the loose end of the tubing to the brine valve in the salt tank.

Connect the Drain Line

1. Plumb the drain line to an appropriate drain abiding by all local, city, and state codes. Use a 3/4" drain line for backwash flow rates of 7 gpm or for drain lines of 7 gpm and less that exceed 20' in length. Use a 1" drain line for backwash flow rates of 10 gpm and 12 gpm.
2. If the drain line is a 5/8" flexible poly tube, slide the nut onto the poly tube, then place the poly tube insert into the end of the poly tube and tighten the nut on to the 3/4" drain line fitting. The nut is only designed for use with flexible poly tube. Use other nuts if attaching different materials. Run line to a drain. Making sure you have a 1 1/2" airgap. You may use a floor drain, standpipe or any open type drain (see Fig. 7 on page 10).

Do not use Vaseline, oils, or other unacceptable lubricants on o-rings. A silicon lubricant may be used on the black o-ring.

Use a pliers or crescent wrench to tighten or unscrew the nut. Do not use a pipe wrench to tighten or loosen nut. Do not use pipe dope or other sealant on threads. Use Teflon tape on the threads of the drain line control fitting when installing 3/4" NPT or 1" straight fitting.

Installation

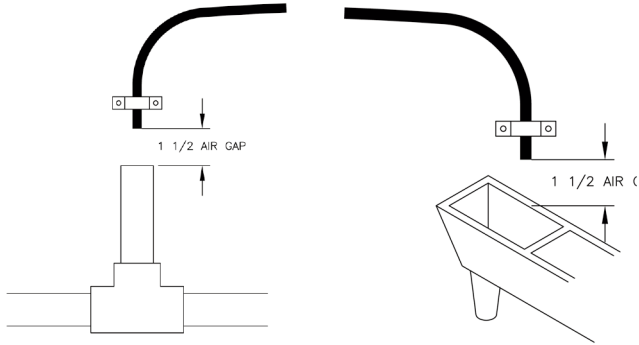

Figure 7: Also be sure drain line has an air gap.

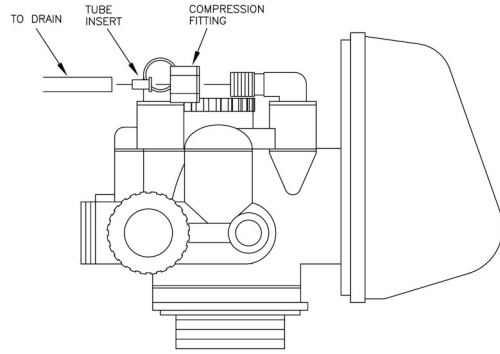

Figure 8: Drain Line Connection

Start Up

1. Confirm that the bypass valve is in the bypass position (see images 9, 10 & 11 below)
2. Place the bypass valve in the "bypass" position or mode (see figures 9-11 below.)
3. Open the user supplied feed water valve. Check for leaks and repair as needed.
4. Open the outlet valve of the bypass.
5. Open a couple inside hot and cold faucets until all air has been purged from the plumbing system. then close the faucets.
6. Initiate an Immediate Manual Regeneration by pressing and holding the "REGEN" button for 3 seconds. This will place the system into "Backwash" mode, unplug the system from its electrical outlet once it has cycled into the backwash position. This will stall the unit in the "Backwash" mode so all air can be purged from the tank.
7. Close the bypass valve.
8. Adjust the user supplied feed water valve to 1/4 open and place the bypass valve into the "Service/Operating Mode" position.
9. Air will come out of the drain line until the backwashing tank is completely purged of air. Then water will flow to drain. Allow water to flow to drain for 15 minutes or until the water to drain is clear of resin color throw.
10. Plug the system back into the electrical outlet and manually cycle the control valve through the remaining regeneration steps by pressing the "Next" button until it arrives in the Service position.
11. Check for system for leaks and repair as needed.
12. Installation is now complete and the system is ready for programming and one cycle of brine tank refill so that the correct amount of water is in the brine tank for the first regeneration cycle. The brine tank refill must be done after programming the system. Add Salt to brine tank, fill the brine tank about 1/2 full, **DO NOT FILL BRINE TANK COMPLETE FULL**

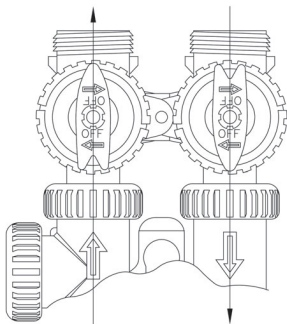

Figure 9: Operating Mode

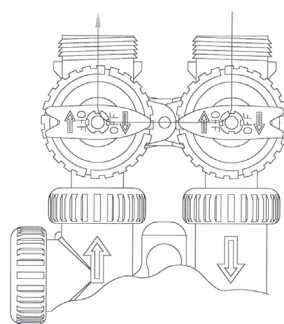

Figure 10: Bypass Mode

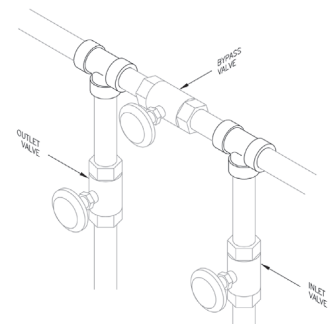

Figure 11: Bypass Mode

PWSR System Programming

PWSR Quick Programming Guide

A quick programming guide has been listed below for convenience specifically for the PWSR series water softening systems. For other programming requirements not listed in the Quick Programming Guide, please see the detailed programming section of this manual.

NOTICE

The electronics in the PWSR control valve are used across a wide variety of control valves and applications, including backwashing filters. All programming for the electronics has been included in this manual for reference however the valve must be programmed for Twin Alternating Softening Applications when called for during valve programming.

NOTICE

The **Water Hardness** level of the feed water needs to be known prior to programming system as well as the **Water Softener Capacity** of the system being installed, to insure proper programming and efficiency of system

Chart 1: Setting Time of Day

Press the Set Clock button	Adjust hours using the Up and Down arrow buttons
Press the Next button to advance to the minutes.	Adjust minutes with the Up and Down arrow buttons.
Press the Next button to set time	To Exit

NOTICE

Once in the programming settings, simply use the **UP** and **DOWN** arrow buttons to change values

Chart 2: Master Programming

To enter the Master Programming mode, press and hold the NEXT and DOWN arrow buttons simultaneously for 3 – 5 seconds	The display will change to SET SOFTENING with the word SOFTENING will be blinking. This indicates you are now in the Master Programming Mode
	System Type – For a WATER SOFTENER , leave this setting alone. If for some reason the display reads SET FILTER , press the UP arrow button and change to SET SOFTENER
Press NEXT Button	Capacity – Enter the CAPACITY of the water softener that you have ie. 30K, 45K, 60K or 90K.
Press NEXT Button	Salt Setting – Enter the desired pounds of salt per regeneration ie. 6 lbs. per cu. ft. of resin for most efficiency, 15 lbs. per cu. ft. for maximum capacity – default setting should be 9 pounds for a 45K water softener – you must confirm
Press NEXT Button	A 30K water softener has 1 cu.ft., 45K has 1.5 cu. ft., 60K has 2 cu. ft. and 90K cu. ft. has 3 cu. ft. Example - 45K water softener would be set to a minimum salt setting of 9 pounds for most efficiency (recommended)
Press NEXT Button	Backwashing Mode - Setting to Normal or Longer. NORMAL is the standard setting. Longer may be needed for well water with heavier sediment issues. Contact Pure Water Technical Support at 1.800.224.1299, then press #2 for details.
Press NEXT Button	Gallon Capacity Mode - Set to AUTO for most efficient setting. Owner's manual has additional settings, contact Pure Water Technical Support for Details. Note: You may see a gallon capacity on this screen, hit the UP arrow button several times until you see AUTO on the screen.
Press NEXT Button	Brine Tank Refill Mode - This setting should be set to POST
Press NEXT Button	Regenerate Flow Mode - This flow setting should be set to Down Flow – dn.
Press NEXT Button	Regeneration Time - This setting should be set to NORMAL
Press NEXT Button	This will complete Master Programming Steps

NOTICE

Next you will need to set up Installer Programming, this **MUST** be done in addition to the Master Programming

Chart 3: Installer Programming

To enter Installation Display Setting Programming mode, press and hold the NEXT and UP arrow buttons simultaneously for 3 - 5 seconds	Hardness Setting - Set the level of hardness in grains per gallon (GPG) present in the raw water. Example: 18 grains per gallon (GPG). Adjust grains per gallon with the Up and Down arrow buttons.
Press Next Button	Day Override. Default should be set to 14 Days. Watts Pure Water water softeners regenerate based on water usage, but this day override setting will come into play if the softener sits idle or has not regenerated and will automatic initiate regeneration on the 14th day.
Press Next Button	Regeneration Time. Default setting is 2:00 AM . If time change is needed, press the UP and DOWN arrow buttons to adjust the hour time.
Press Next Button	Press the UP and DOWN arrow button to adjust the minutes.
Press Next Button	

Programming completed, Valve will return to normal mode and will be in service.

If you have additional questions regarding your water softener programming, please contact Pure Water Technical Support at 1.800.224.1299, then press #2

Control Programming

Installer (I) Displays/Settings

STEP 1I – Press NEXT and arrow up simultaneously for 3 seconds.

STEP 2I – Hardness: Set the amount of hardness in grains of hardness as calcium carbonate per gallon using, arrow down or arrow up but-tons. The default is 20 with value ranges from 1 to 150 in 1 grain increments. Note the grains per gallon can be increased if soluble iron needs to be reduced. Press NEXT to go to step 3I. Press REGEN to exit Installer Displays/Settings.

STEP 3I – Day Override: When gallon capacity is set to off, sets the number of days between regeneration's. When gallon capacity is set to AUTO or to a number sets the maximum number of days between regeneration. If value set to "off" regeneration initiation is based solely on gallons used. If value is set as a number (allowable range from 1 to 28) a regeneration initiation will be called for on that day even if sufficient number of gallons were not used to call for a regeneration. Set Day Override using arrow buttons: number to days between regeneration (1 to 28); or OFF.

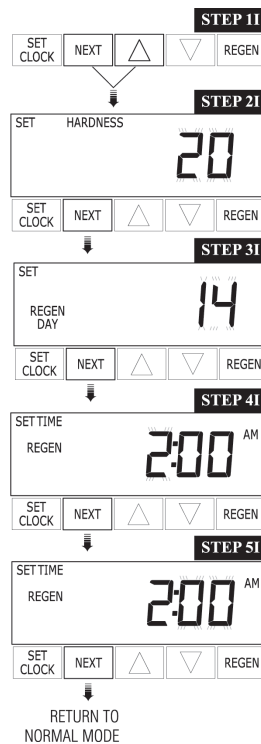

Press NEXT to go to step 4I. Press REGEN to return to previous step.

STEP 4I – Next Regeneration Time (hour): Set the hour of day for regeneration using down or up arrow buttons. AM/PM toggles after 12. The default time is 2:00 am. This display shows "REGEN on 0 GAL" if "on 0" is selected in Step 9S or Step 7F. Press NEXT to go to step 5I. Press REGEN to return to previous step.

STEP 5I – Next Regeneration Time (minutes): Set the minutes of day regeneration using down or up arrow buttons. This display not be shown if "on 0" is selected in Step 9S or Step 7F. Press NEXT to exit Installer Displays/ Settings. Press REGEN to return to previous step.

To initiate a manual regeneration immediately, press and hold the "REGEN" button for three seconds. The system will beam to regenerate immediately. The control valve may be stepped through the various regeneration cycles by pressing the "REGEN" button.

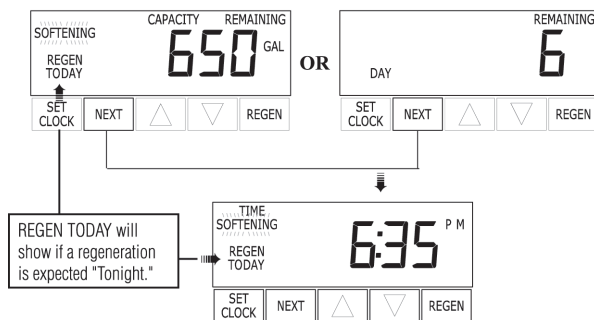

Regeneration Mode

Typically a system is set to regenerate at a time of low water usage. An example of a time with low water usage is when a household is asleep.



If there is a demand for water when the system is regenerating, untreated water will be used.

When the system begins to regenerate, the display will change to include information about the step of the regeneration process and the time remaining for that step to be completed. The system runs through the steps automatically and will reset itself to pro-vide treated water when the regeneration has been completed.

General Operation

User (U) Displays/Settings

When the system is operating one of two displays will be shown. Pressing NEXT will alternate between the displays. One of the displays is always the current time of day. The second display is one of the following: days remaining or gallons remaining. Days remaining are the number of days left before the system goes through a regeneration cycle. Capacity remaining is the number of gallons that will be treated before the system goes through a regeneration cycle. The user can scroll between the displays as desired.

If the system has called for a regeneration that will occur at the preset time of regeneration, the words REGEN TODAY will appear on the display.

When water is being treated (i.e. water is flowing through the system) the word "Softening" flashes on the display.

NOTICE

If brine tank does not contain salt, fill with salt and wait at least two hours before regenerating.

Manual Regeneration

Sometimes there is a need to regenerate the system, sooner than when the system calls for it, usually referred to as manual regeneration. There may be a period of heavy water usage because of guests or a heavy laundry day.

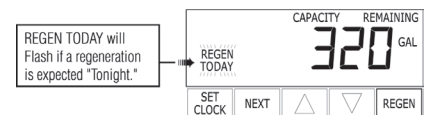

To initiate a manual regeneration at the preset delayed regeneration time, when the regeneration time option is set to "NORMAL" or "NORMAL + on 0", press and release "REGEN". The words "REGEN TODAY" will flash on the display to indicate that the system will regenerate at the preset delayed regeneration time. If you pressed the "REGEN" button in error, pressing the button again will cancel the request. Note: If the regeneration time option is set to "on 0" there is no set delayed regeneration time so "REGEN TODAY" will not activate if "REGEN" button is pressed.

To initiate a manual regeneration immediately, press and hold the "REGEN" button for three seconds. The system will begin to regenerate immediately. The request cannot be cancelled.

Programming (Note)

Set Time of Day

The user can also set the time of day. Time of day should only need to be set after extended power outages or when day-light savings time begins or ends. If an extended power outage occurs, the time of day will flash on and off which indicates the time of day should be reset.

STEP 1U – Press SET CLOCK.

STEP 2U – Current Time (hour): Set the hour of the day using down or up arrow buttons. AM/PM toggles after 12. Press NEXT to go to step 3U.

STEP 3U – Current Time (minutes): Set the minutes of the day using down or up arrow buttons. Press NEXT to exit Set Clock. Press REGEN to return to previous step.

POWER LOSS If the power goes out for less than two hours, the system will automatically reset itself. If an extended power outage occurs, the time of day will flash on and off which indicates the time of day should be reset. The system will remember the rest.

ERROR MESSAGE If the word “ERROR” and a number are alternately flashing on the display contact the OEM for help. This indicates that the valve was not able to function properly.

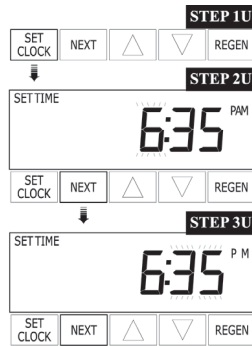

Sanitizing the System

1. At completion of softener installation you should sanitize the system.
2. Take the lid off of the salt tank and then take the cap off of the brine well. Pour about 3/4 to 1 1/2 ounce of 5.25% common household bleach into the brine well. Replace cap and lid. (This can be done with or without salt in tank.)
3. Press and hold regeneration button to start the regeneration process immediately.

Each water softener is handled in a manner to keep clean and sanitary. The materials used will not contaminate your water supply or cause bacteria to grow. However, during shipping, storage, installation, and operation, bacteria growth could develop. Some water supplies may require periodic disinfecting.

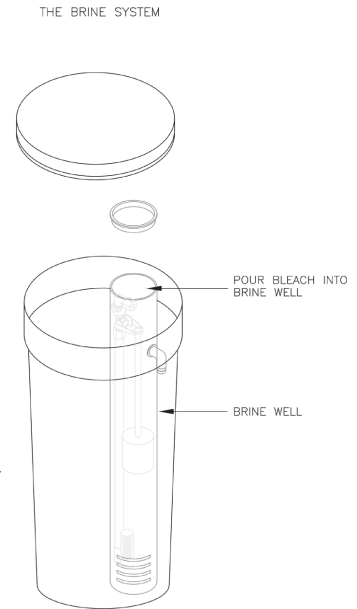

Figure 16:
The Brine System

System Components Described

Components:

The control valve consists of the following components

1. Drive Assembly
2. Drive Cap Assembly, Main Piston and Regenerant Piston
3. Spacer Stack Assembly
4. Injector Cap, Screen, Injector Plug and Injector
5. Refill Flow Control Assembly or Refill Port Plug
6. Drain Line Flow Control and Fitting Assembly
7. Water Meter or Meter Plug
8. Installation Fitting Assemblies
9. Bypass Valve (optional)

Drive Assembly

The drive assembly consists of the following parts:

- Drive Bracket
- Printed Circuit (PC) Board
- Motor
- Drive Gears
- Drive Gear Cover

The drive bracket holds the PC board, the motor, the drive gears and the drive gear cover in place.

The PC board receives and retains information, displays the information, determines when to regenerate and initiates regeneration. The display shows different types of information in the initial system set up (for softeners or filters), installer displays/settings, diagnostics, and valve history or user displays/settings.

The PC board's two-prong jack connects wires to the direct current (DC) motor. The motor is held in place on the drive bracket by a spring-loaded clip and a small bulge in the plastic, which fits in one of the slots on the motor housing. The motor turns drive gears that drive the piston to cycle positions for backwashing, regeneration, rinsing, refill or service. The motor is fully reversible (turns both ways) and changes direction of rotation to change the direction of piston motion. The motor is easily replaced if necessary.

There are three drive gears held in place by the drive gear cover. All three drive gears are the same size. A reflective coating is applied to the gears. As the center drive gear turns a light shines on the coating and a light sensing diode determines if a light pulse was returned. The PC board counts the pulses and determines when to stop driving the motor.

System Components Described

Drive Cap Assembly

Main Piston and Regenerant Piston

The drive gears turn the main gear of the drive cap assembly, which moves the piston. The screw-driven, horizontally moving piston stops at specific positions to direct the flow of water to backwash, regenerate, rinse or refill. The PC board determines the position of the piston by counting pulses produced when the piston is moved. An optical sensor looking at one of the reduction drive gears generates these pulses. Each cycle position is defined by a number of pulses. The counter is zeroed each time the valve goes to the service position. The PC board finds the service position by noting the increase in current delivered to the motor when the mechanical stop at the service position is reached. This method of controlling piston position allows for greater flexibility and requires no switches or cams.

One of two main pistons is always used:

1. The down flow piston which is used when the control valve is used as a down flow softener, regenerating filter or non regenerating filter: or
2. The up flow piston, which is used when the control valve is used as an up flow softener.

If the control valve is used as a softener or a regenerating filter, are generant piston must be attached to the main piston. If the control valve is to be used on system that does not require a regenerant to be added the regenerant piston must be removed.

Spacer Stack Assembly

The spacer stack assembly provides the necessary flow passage for water during the different cycles. The all-plastic spacer stack assembly (patent pending) is a one-piece design, which allows the stack to be removed using your fingers.

The exterior of the stack is sealed against the body bore with self-lubricating EPDM o-rings while the interior surface is sealed against the piston using slippery self cleaning directional (one way) silicone lip seals. The lip seals are red or clear in color and have a special slippery coating so that the piston does not need to be coated or lubricated.

Injector

The screen, injector and/or injector plug(s) are installed under the injector cap in an easy to access location on top of the valve. The injector cap contains four slots so no water accumulates in the cap. The injector cap is designed to be hand tightened.

Under the injector cap there is an easy to clean removable screen to prevent fouling of the injector. There are two holes under the injector cap labeled "DN" and "UP". The holes will be filled with a plug or an injector.

The plug (#KC113010-IZ) prevents water from traveling a certain pathway. The injector lets water pass through the pathway. The self-priming injector increases the velocity of the water, creating a zone of negative pressure that draws in the concentrated liquid regenerant, such as sodium chloride (brine), potassium permanganate, sodium hydroxide, hydrochloric acid, etc. The regenerant blends with the stream of water, which passes through the media to regenerate the bed.

The injector provides a consistent regenerant/water mixture ratio over the entire operating pressure range of the control valve. The injector provides good performance in a variety of applications, which may involve elevated drain lines and long regenerant draw lengths. Injectors are chosen by knowing the type, amount, and regenerant flow rate for a particular type of media. The color coded injectors give different regenerant draw, slow rinse and total flow rates over the pressure range. See Table 10 for color codes.

Table 10: Injector Order Information

Part #	Color	Tank Dia.
KC11V3010-1D	Red	9"
KC11V3010-1E	White	10"
KC11V3010-1F	Blue	12"
KC11V3010-1G	Yellow	13"
KC11V3010-1I	Orange	16"
KC11V3010-1K	Lt Green	21"

Refill Flow Control Assembly

The refill flow control assembly consists of a refill flow elbow, refill flow control retainer assembly, refill flow control, poly tube insert and nut assembly. The refill flow control retainer fits in the refill elbow. The refill flow control retainer houses the refill flow control, which controls the flow rate when the regenerant tank is being refilled. The refill flow control is a flexible washer-like part with a small orifice and a precision molded contour that delivers a steady 0.5 gpm regenerant tank refill rate at varying inlet pressures. Refill is accomplished with treated water.

The refill flow control assembly is installed in an easy to access refill elbow located on top of the control valve. The refill flow control assembly is attached to the control valve with a locking clip. The locking clip allows the elbow to rotate 270 degrees so the outlet can be orientated towards the regenerant tank.

Drain Line Flow Control/Fitting

The drain line flow control assembly includes a drain line flow control and a fitting. The drain line flow control allows proper media bed expansion by regulating the flow rate to the drain.

The drain line flow control is a flexible washer-like part with an orifice and a precision molded contour. The flow rates are within +/- 10% over the pressure range of 1-0 psi to 125 psi. The flexible washer-like parts are identified with three numbers, which correspond to the flow rate in gallons per minute. See Table 11.

The drain line flow control and fitting are located on top of the control valve and replaceable without the use of special tools.

Table 11: Drain Line Flow Control (3/4" Fitting)

Part #	Number on Backwash Flow Rate	
	Fitting	GPM
KC11V3162-022	22	2.2
KC11V3162-027	27	2.7
KC11V3162-042	42	4.2
KC11V3162-053	53	5.3
KC11V3162-075	75	7.5
KC11V3190-110	110	11

System Components Described

The drain line flow control can be installed in the standard 1/4" drain line elbow, which accommodates 5/8" poly tube or 3/4" NPT drain line connections. The optional nut and poly tube insert for the 3/4" drain line elbow is designed for use with flexible poly tube only. The 3/4" drain line elbow can be rotated 180 degrees so the outlet can be orientated to the nearest drain. The same retainer is used for all drain line flow controls for the 3/4" fitting.

Water Meter or Meter Plug

The water meter is installed on the outlet side of the control valve. The water meter uses a turbine to total gallons of treated water. The turbine rotates with the flow of water and reports its rate of rotation through Hall-effect 8 circuitry to the printed circuit (PC) board. This rotation permits the PC board to record the total volume of treated water and the flow rate. The small centrally located magnet is shielded from water, which reduces substantially iron-fouling problems with the turbine. The turbine is accurate to within $\pm 5\%$ over a wide operating flow rate range (0.25 gpm up to control valve maximums) and has a very low pressure drop. Water used for regeneration is not metered. If the control valve is set to prefill the regenerant, water used between the prefill cycle up to the start of the regeneration cycle is metered. If the control valve is in regeneration mode (e.g. a backwash cycle) and there is a water demand that water usage is not metered.

When facing the front of the control valve, the water meter is positioned on the left-hand side of the control valve. Allow sufficient clearance to clean and repair the water meter without disconnecting the plumbing or disassembling any other parts of the control valve.

A unique feature of this control valve is the ability to display actual water usage for the last 63 days. The values are initially stored as " _ " because it is unknown. As days pass values are stored as "O" for no flow or the actual number of -gallons. The counting of the gallons starts at the regeneration time. If no regeneration time can be set (i.e. when the valve is set for immediate regeneration) the counting, of gallons starts at 12 a.m. Day 1 is yesterday, day 2 the day before yesterday, etc. As new values are added the oldest history disappears.

Another unique feature is that the valve automatically calculates a reserve capacity when set up as a softener with "Gallons Capacity" set to "AUTO". The reserve capacity for a given day of the week is the middle value stored for the last three non-trivial water usages (i.e. less than 20 gallons day) in seven-day intervals which is then adjusted either upward or downward depending upon the difference between today's water usage and the estimated reserve capacity.

Installation Fitting Assemblies

The installation fittings are used to connect the optional bypass or the control to the plumbing system. There are four installation-fitting assemblies available:

1. 1" NPT elbow
2. 3/4" & 1" PVC solvent weld elbow fitting
3. 1" straight brass sweat fitting **
4. 3/4" straight brass sweat Fitting **

Both elbow fittings have a unique drill out feature to allow a 1/4" NPT connection to the inlet and/or outlet which can be used for a RO feed, test ports, pressure tap ports, etc.

The installation fitting assemblies are sold in pairs and consist of two fittings, two nuts, two split rings and two o-rings. The installation fitting assemblies and the bypass valve are sold separately from the control valve.

Bypass Valve

The bypass valve is typically used to isolate the control valve from the plumbing system's water pressure in order to perform control valve repairs or maintenance. The W100SM bypass valve is particularly unique in the water treatment industry due to its versatility and state of the art design features. The 1" full flow bypass valve incorporates four positions including a diagnostic position that allows service personal to work on a pressurized system while still providing untreated bypass water to the facility or residence. Its completely non-metallic, all plastic design allows for easy access and service-ability without the need for tools.

The bypass body and rotors are glass filled Noryl and the nuts and caps are glass filled polypropylene. All seals are self-lubricating EPDM to help prevent valve seizing after long periods of non-use. Internal o-rings can easily be replaced if service is required.

The bypass consists of two interchangeable plug valves that are operated independently by red arrow shaped handles. The handles identify the flow direction of the water. The plug valves enable the bypass valve to operate in four positions.

1. **Normal Operation Position:** The inlet and outlet handles point in the direction of flow indicated by the engraved arrows on the control valve. Water flows through the control valve during normal operation and this position also allows the control valve to isolate the media bed during the regeneration cycle. (See Figure 17)
2. **Bypass Position:** The inlet and outlet handles point to the center of the bypass, the control valve is isolated from the water pressure contained in the plumbing system. Untreated water is supplied to the plumbing system. (See Figure 18)
3. **Diagnostic Position:** The inlet handle points in the direction of flow and the outlet handle points to the center of bypass valve, system water pressure is allowed to the control valve and the plumbing system while not allowing water to exit from the control valve to the plumbing. (See Figure 19)
4. **Shut Off Position:** The inlet handle points to the center of the bypass valve and the outlet handle points in the direction of flow, the water is shut off to the plumbing systems. If water is available on the outlet side of the softener it is an indication of water bypass around the system (i.e. a plumbing connection somewhere in the building bypasses the system). (See Figure 20)

* Some semiconductor materials exhibit a phenomenon in the presence of a magnetic field that is adaptable to sensing devices. When a current is passed through one pair of wires attached to a semiconductor, another pair of wires properly attached and oriented with respect to the semiconductor will develop a voltage proportional to the magnetic field present and the current in the other pair of wires. Holding the exiting current constant and moving a permanent magnet near the semiconductor produces a voltage output proportional to the movement of the magnet. Hall-effect devices provide a high-speed response, excellent temperature stability and no physical contact.

** Has not been tested for compliance with California Proposition 65 so this fitting should not be installed in California.

Drawings and Part Numbers

Brine Tank and Softener Tank

PARTS LIST FOR BRINE TANK

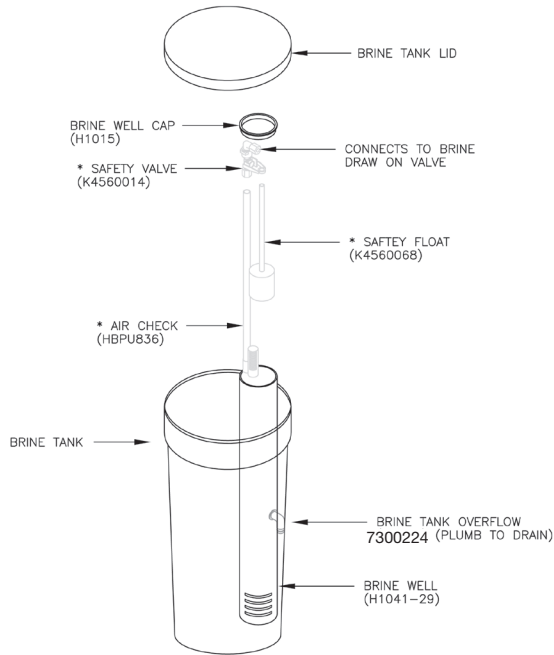

* H7007 - INCLUDES THE AIR CHECK, SAFETY VALVE & FLOAT ASSEMBLY

Figure 17

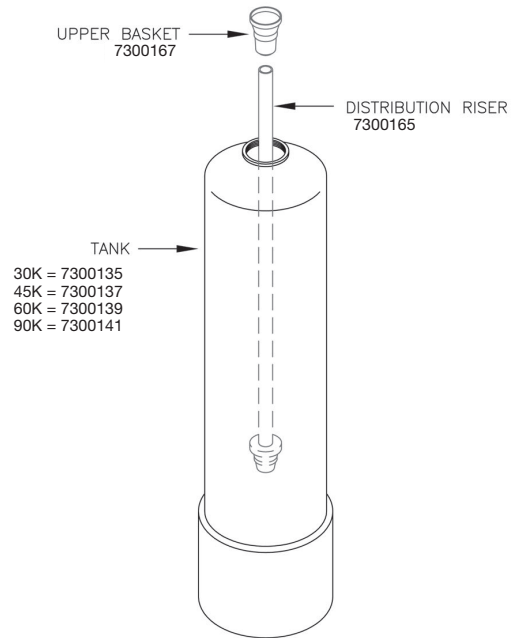
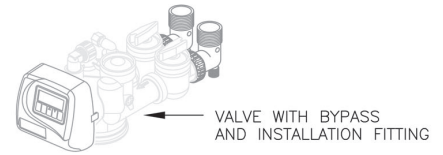
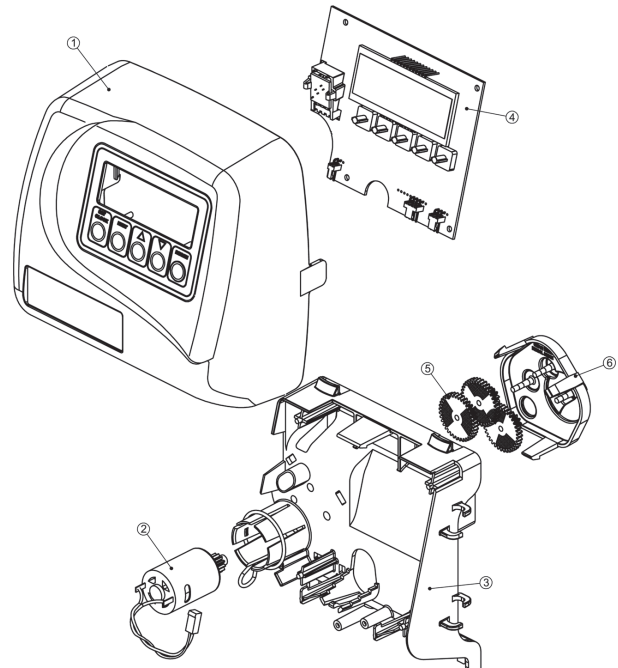

Figure 18

Front Cover and Drive Assembly

DRAWING NO.	ORDER NO.	DESCRIPTION	QTY.
1	7300839	W100SM Front Cover ASY	1
2	7300833	W100SM Motor	1
3	KC12F3106-01	W100SM Drive Bracket & Spring Clip	1
4	7300834	W100SM PC Board	1
5	KC12V3110	W100SM Drive Gear 12x36	3
6	KC12V3109	W100SM Drive Gear Cover	1
	KC12V3002	W100SM Drive ASY	*
Not Shown	7300838	W100SM Transformer 110V-12V	1



Drawings and Part Numbers

Drive Cap Assembly, Downflow Piston, Upflow Piston, Regenerant Piston and Spacer Stack Assembly

DRAWING NO.	ORDER NO.	DESCRIPTION	QTY.
1	7300826	W100SM Spacer Stack Assembly	1
2	KC12V3004	Drive Cap ASY	1
3	KC12V3135	O-ring 228	1
4	7300832	W100SM Piston Downflow ASY	1
5	7300836	W100SM Regenerant Piston	3
6	KC12V3180	O-ring 337	1

Note: The regenerant piston is not used in backwash only applications

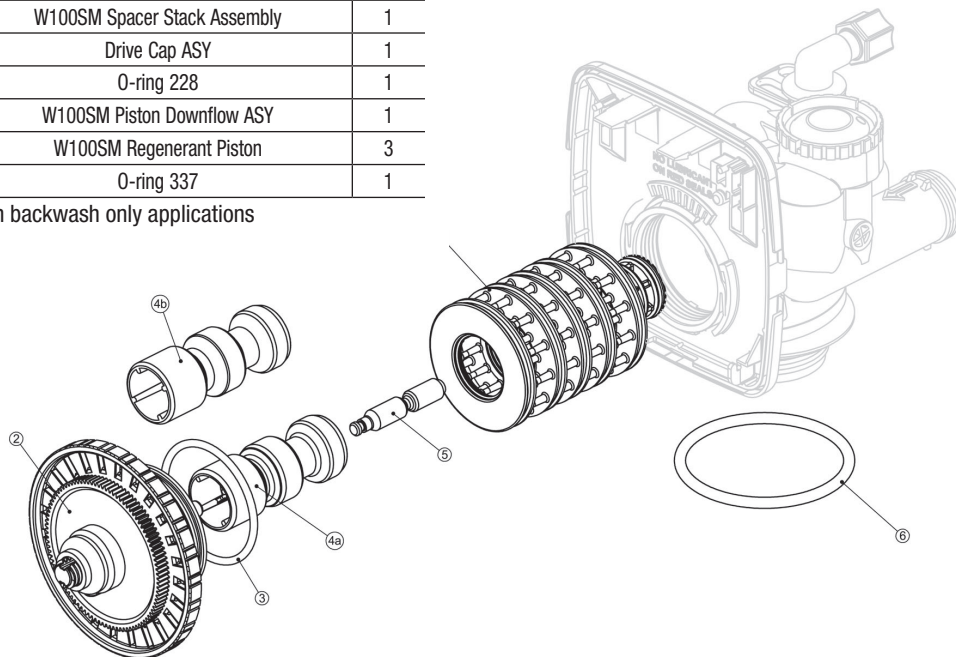

Injector Cap, Injector Screen, Injector, Plug and O-ring

Drawing No.	Order No.	Description	Qty.
1	KC12V3176	Injector Cap	1
2	KC12V3152	O-ring 135	1
3	KC12V3177	Injector Screen	1
4	KC12V3010-12	W100SM Injector ASY Z Plug	1
5	KC12V3010-10	W100SM Injector ASY D Red	1
	KC12V3010-IE	W100SM Injector ASY E White	
Not Shown	KC12V3170	O-ring 011	*
Not Shown	KC12V3171	O-ring 013	*

*The Injector plug and the injector each contain one 011 (lower) and 013 (upper) o-ring.

Note: For upflow position, injector is located in the up hole and injector plug in the down hole. For a filter that only backwashes injector plugs are located in both holes.

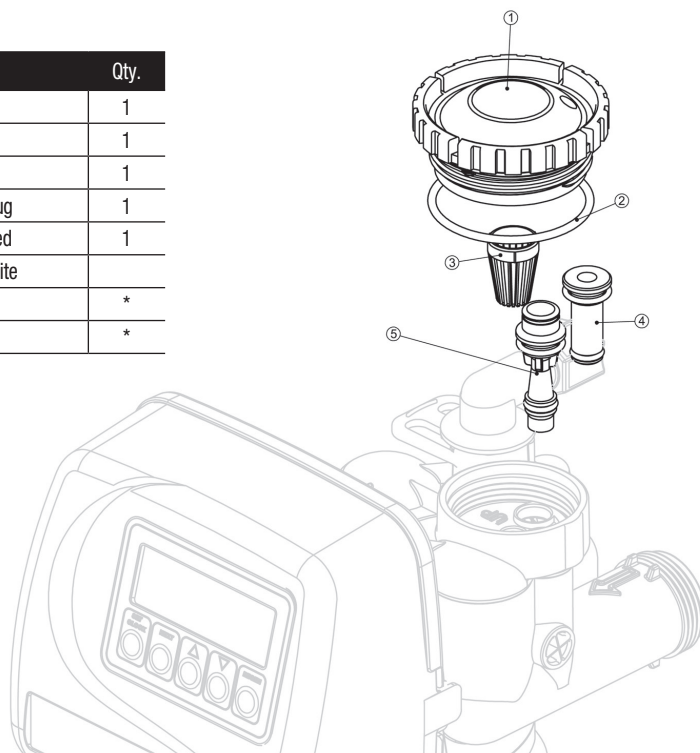

Drawings and Part Numbers

Brine Line Connection

ORDER NO.	DESCRIPTION
V4144-01	3/8" Quick Connect Fitting

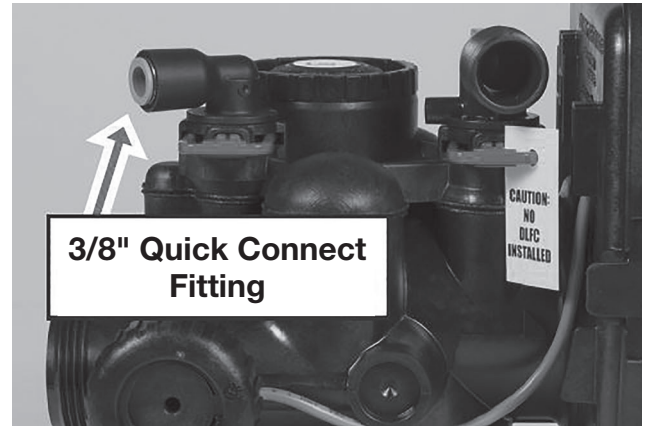

Drain Line - 3/4"

DRAWING NO.	ORDER NO.	DESCRIPTION	QTY.
1	KC12H4615	Elbow Locking Clip	1
2	KC12PKP10T58	Polytube insert 5/8	Option
3	KC12V3192	W100SM Nut 3/4 Drain Elbow	Option
4	KC12V3158-01	W100SM Drain Elbow 3/4 Male ASY	1
5	KC12V3163	O-ring 019	1
6	KC12V3159-01	W100SM DLFC Retainer ASY	1
7	KC12V3162-022	W100SM DLFC 2.2 gpm for 3/4	*
	KC12V3162-027	W100SM DLFC 2.7 gpm for 1"	*

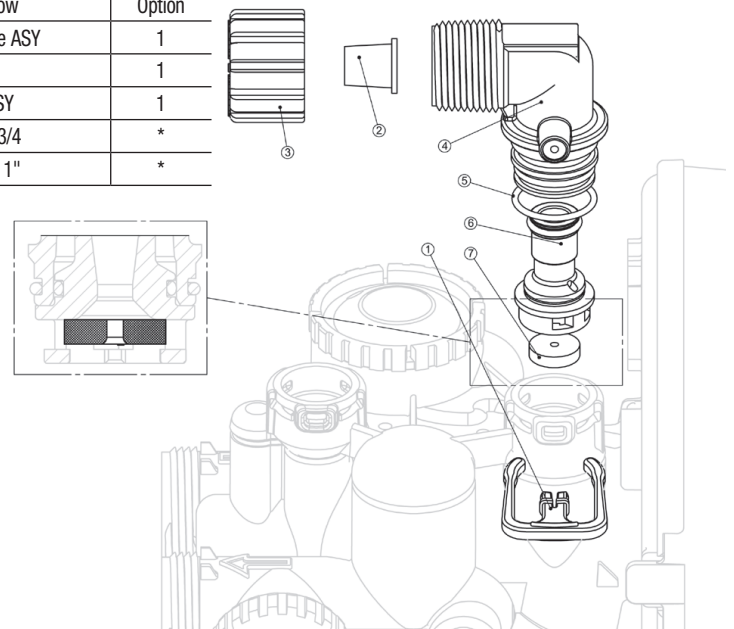

Drawings and Part Numbers

Water Meter and Meter Plug

ORDER NO.	DESCRIPTION
7300827	Water Meter Plug Assembly

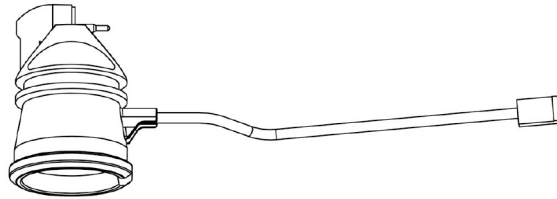

Installation Fitting Assemblies

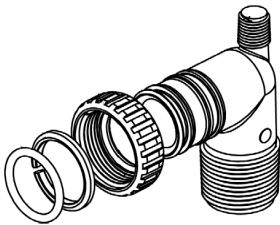

ORDER NO.	DESCRIPTION
0002169	1" PVC Male NPT Elbow (pair)

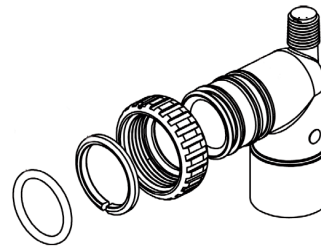

ORDER NO.	DESCRIPTION
KC11V3007-01	3/4" & 1" PVC Socket 90 Elbow (pair)

ORDER NO.	DESCRIPTION
0002170	1" Brass Sweat

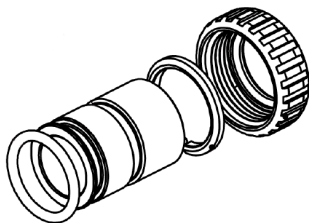

ORDER NO.	DESCRIPTION
0002171	3/4" Brass Sweat (pair)

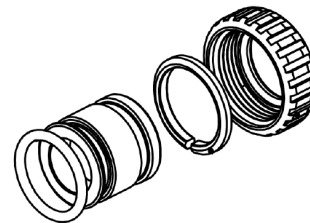

Drawings and Part Numbers

Bypass Valve Assembly

ORDER NO.	DESCRIPTION
0002167	Bypass Valve Assembly

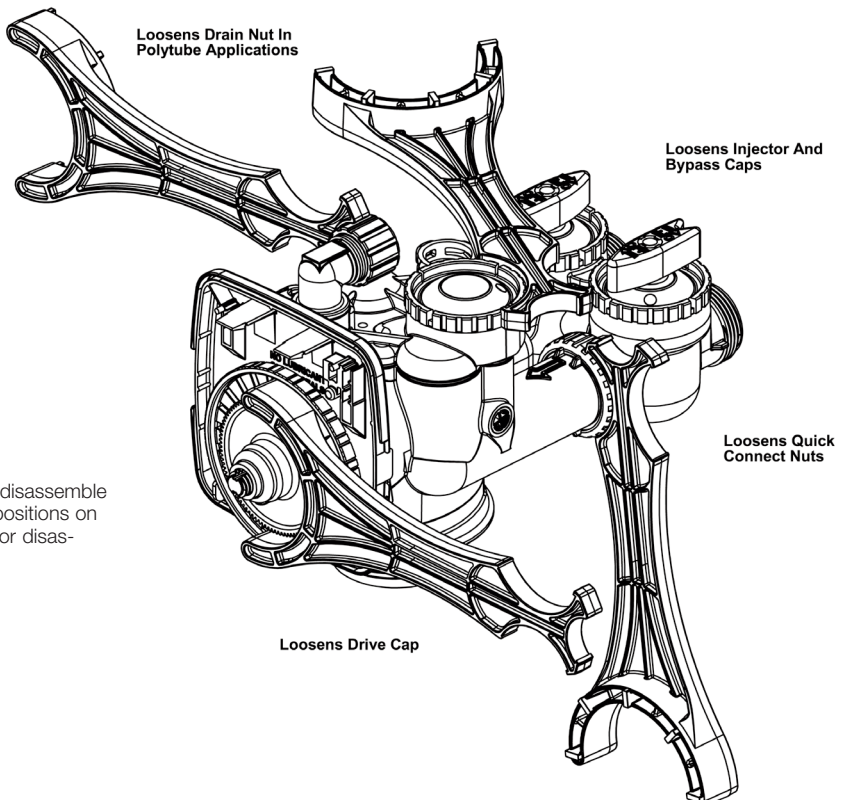
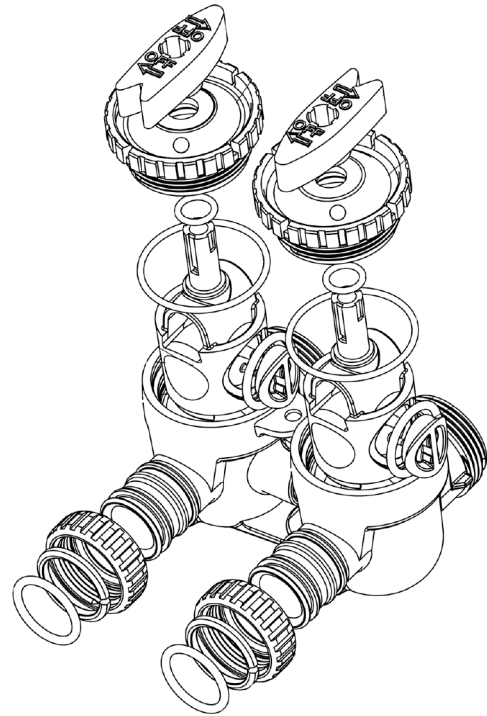

PWSR Wrench

(Order No. 7300839)

Although no tools are necessary to assemble or disassemble the valve, the PWSR Wrench (shown in various positions on the valve) may be purchased to aid in assemble or disassembly.

Drawings and Part Numbers

Flow Diagram...Service

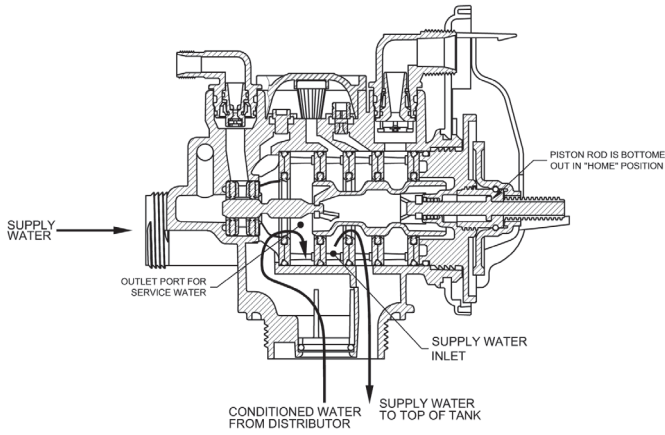

Flow Diagram...Rinse

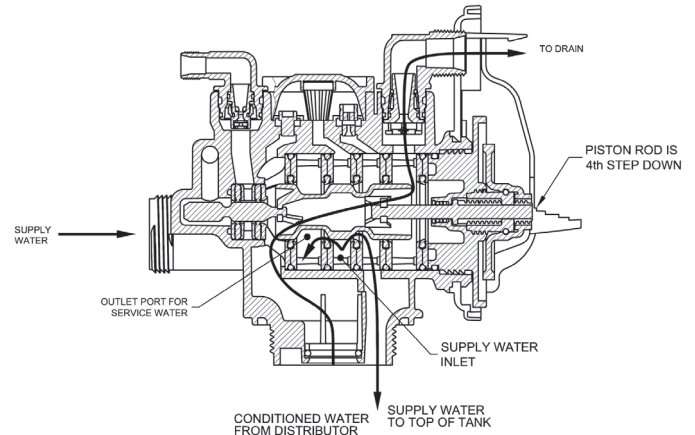

Flow Diagram...Backwash

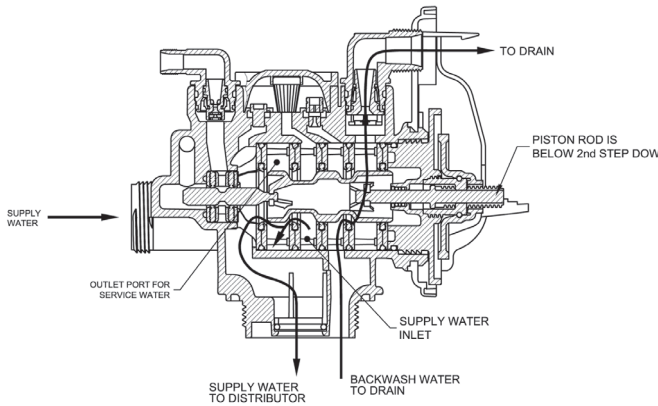

Flow Diagram...Fill

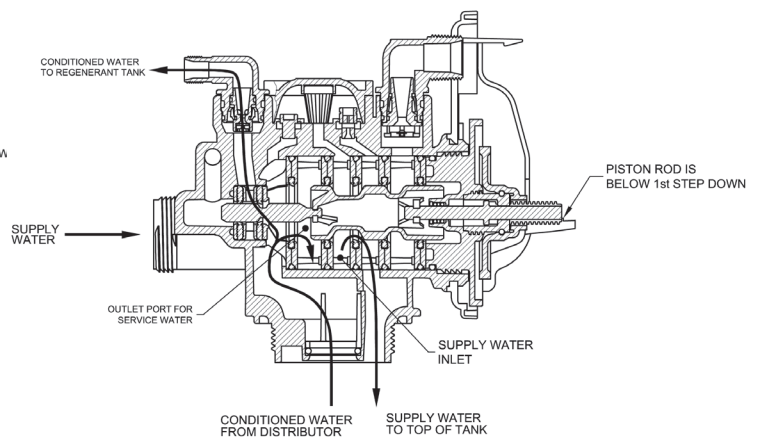

Flow Diagram...Downflow Brine

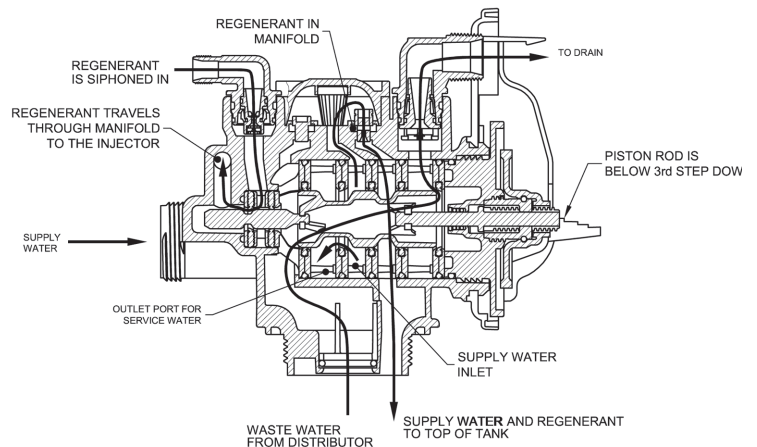

Troubleshooting

System Troubleshooting

Problem	Cause	Correction
1. Loss of Resin	A. Broken distribution tube	A. Replace distribution tube.
	B. Inlet/Outlet connection reversed.	B. Reconnect inlet/outlet connection properly.
2. Softener fails to regenerate.	A. Electrical service to unit has been interrupted.	A. Assure permanent electrical service (check fuse, plug, pull chain, or switch).
	B. Timer is defective.	B. Replace timer.
	C. Power failure.	C. Reset time of day.
3. Hard Water	A. Bypass valve is open.	A. Close bypass valve.
	B. No salt in brine tank.	B. Add salt to brine tank and maintain salt level above water level.
	C. Injector screen plugged.	C. Clean injector screen.
	D. Insufficient water flowing into brine tank.	D. Check brine tank fill time and clean brine line flow control if plugged
	E. Hot water tank hardness	E. Repeated flushing of the hot water tank is required.
	F. Leak at distributor tube.	F. Make sure distributor tube is not cracked. Check "O" Ring and tube pilot.
	G. Internal valve leaking.	G. Replace seals and spacers and or piston.
4. Unit used too much salt.	A. Improper salt setting.	A. Check salt usage and sat setting.
	B. Excessive water in brine tank.	B. See Problem No. 8.
5. Loss of water pressure.	A. Iron buildup in line to water conditioner.	A. Clean line to water conditioner.
	B. Iron buildup in water conditioner.	B. Clear control and add mineral cleaner and Increase frequency regeneration.
	C. Inlet of control plugged due to foreign material broken loose from pipes by recent work done on plumbing system.	C. Remove piston and clean control.
6. Loss of mineral through drain line.	A. Air in water system.	A. Assure that well system has proper air eliminator control. Check for dry well condition.
7. Iron in conditioned water.	A. Fouled mineral bed.	A. Check backwash, brine draw, and brine tank fill. Increase frequency of regeneration. Increase backwash time.

Troubleshooting

System Troubleshooting (continued)

Problem	Cause	Correction
8. Excessive water in brine tank.	A. Plugged drain line flow control.	A. Clean flow control.
	B. Plugged injector system.	B. Clean injector and screen.
	C. Foreign material in brine valve.	C. Replace timer.
	D. Defective controller.	D. Replace controller.
	E. Foreign material in brine line flow control.	E. Clean brine line flow control.
9. Softener fails to draw brine.	A. Drain line flow control is plugged.	A. Clean drain line flow control.
	B. Injector is plugged.	B. Clean injector.
	C. Injector screen plugged.	C. Clean screen.
	D. Line pressure is too low.	D. Increase line pressure to 20 P.S.I.
	E. Internal control leak.	E. Change seals, spacers, and piston assembly.
10. Control cycles continuously.	A. Broken or shorted switch	A. Determine if switch or timer is faulty and replace it, or replace complete power head.
11. Drain flows continuously.	A. Piston is not positioned correctly when in service.	A. Check timer program and positioning of control. Replace power head assembly if not positioning properly.
	B. Foreign material in control.	B. Remove power head assembly and inspect bore. Remove foreign material and check control in various regeneration positions.
	C. Internal control leak	C. Replace seals and piston assembly.
12. Brine tank fills during brine step.	A. Clogged drain.	A. Replace drain line.
	B. Internal piston seal leaks.	B. Replace seals in piston assembly.

See Troubleshooting Programming (next page)

Troubleshooting

Troubleshooting Programming

Problem	Possible Cause	Solution
1. Timer does not display time of day	a. Transformer unplugged	a. Connect power
	b. No electric power at outlet	b. Repair outlet or use working outlet
	c. Defective transformer	c. Replace transformer
	d. Defective PC board	d. Replace PC board
2. Timer does not display correct time of day	a. Switched outlet	a. Use uninterrupted outlet
	b. Power outage	b. Reset time of day
	c. Defective PC board	c. Replace PC board
3. No softening display when	a. Bypass valve in bypass position	a. Put bypass valve in service position
	b. Restricted/stalled meter turbine	b. Remove meter and check for rotation or foreign material
	c. Defective meter	c. Replace meter
	d. Defective PC board	d. Replace PC board
4. Control valve regenerates at wrong time of day of day	a. Power outages	a. Reset control valve to correct time
	b. Time of day not set correctly	b. Reset to correct time of day
	c. Time of regeneration incorrect	c. Reset regeneration time
	d. Control valve set at "on 0" (immediate regeneration)	d. Check control valve set-up procedure regeneration time option
	e. Control valve set at NORMAL on 0	e. Check control valve set-up procedure regeneration time option
5. ERROR followed by code number Error Code 1001 -Unable to recognize start of regeneration Error Code 1002 - Unexpected stall Error Code 1003 - Motor ran to long, timed out trying to reach next cycle position Error Code 1004 - Motor ran to long, timed out trying to reach home position If other Error Codes display contact the factory.	a. Control valve has just been serviced	a. Press NEXT and REGEN for 3 seconds or unplug power source Jack (black wire) and plug back in to reset control valve
	b. Foreign matter is lodged in control valve	b. Check piston and spacer stack assembly for foreign matter
	c. High drive forces on piston	c. Replace piston(s) and spacer stack assembled.
	d. Control valve piston not in home position	d. Press NEXT and REGEN for 3 seconds or unplug power source jack (black wire) and plug back into reset control valve
	e. Motor not inserted fully to engage pinion, motor wires broken or disconnected, motor failure	e. Check motor and wiring. Replace motor if necessary
	f. Drive gear label dirty or damaged missing or broken gear	f. Replace or clean drive gear
	g. Drive bracket incorrectly aligned to back plate	g. Reset drive bracket properly
	h. PC board is damaged or defective	h. Replace PC board
	i. PC board incorrectly aligned to drive bracket	i. Ensure PC board is correctly snapped on to drive

Troubleshooting

Troubleshooting Programming (continued)

Problem	Possible Cause	Solution
6. Control valve stalled in regeneration	a. Motor not operating	a. Replace motor
	b. No electric power at outlet	b. Repair outlet or use working outlet
	c. Defective transformer	c. Replace transformer
	d. Defective PC board	d. Replace PC board
	e. Broken drive gear or drive cap assembly	e. Replace drive gear or drive cap assembly
	f. Broken piston retainer	f. Replace drive cap assembly
	g. Broken main or regenerant piston	g. Replace main or regenerant piston
7. Control valve does not regenerate automatically when REGEN button is depressed and held	a. Transformer unplugged	a. Connect transformer
	b. No electric power at outlet	b. Repair outlet or use working outlet
	c. Broken drive gear or drive cap assembly	c. Replace drive gear or drive cap assembly
	d. Defective PC board	d. Replace PC board
8. Control valve does not regenerate automatically but does when REGEN button is depressed	a. Bypass valve in bypass position	a. Put control valve in service position
	b. Meter connection disconnected	b. Connect meter to PC board
	c. Restricted/stalled meter turbine	c. Remove meter and check for rotation or foreign matter
	d. Defective meter	d. Replace meter
	e. Defective PC board	e. Replace PC board
	f. Set-up error	f. Check control valve set-up procedure
9. Time of day flashes on and off	a. Power has been out more than two hours, the transformer was unplugged and then plugged back into the wall outlet, the transformer plug was unplugged and then plugged back into the board or the NEXT and REGEN buttons were pressed to reset the valve.	a. Reset the time of day

NOTES

LIMITED WARRANTY: Certain Watts products come with a limited warranty from Watts Regulator Co. Other products may have no warranty or are covered by the original manufacturer's warranty only. For specific product warranty information, please visit www.watts.com or the published literature that comes with your product. Any remedies stated in such warranties are exclusive and are the only remedies for breach of warranty. **EXCEPT FOR THE APPLICABLE PRODUCT WARRANTY, IF ANY, WATTS MAKES NO OTHER WARRANTIES, EXPRESS OR IMPLIED. TO THE FULLEST EXTENT PERMITTED BY APPLICABLE LAW, WATTS HEREBY SPECIFICALLY DISCLAIMS ALL OTHER WARRANTIES, EXPRESS OR IMPLIED, INCLUDING BUT NOT LIMITED TO THE IMPLIED WARRANTIES OF MERCHANTABILITY AND FITNESS FOR A PARTICULAR PURPOSE, AND IN NO EVENT SHALL WATTS BE LIABLE, IN CONTRACT, TORT, STRICT LIABILITY OR UNDER ANY OTHER LEGAL THEORY, FOR INCIDENTAL, INDIRECT, SPECIAL OR CONSEQUENTIAL DAMAGES, INCLUDING, WITHOUT LIMITATION, LOST PROFITS OR PROPERTY DAMAGE, REGARDLESS OF WHETHER IT WAS INFORMED ABOUT THE POSSIBILITY OF SUCH DAMAGES.**



USA: Tel: (800) 224-1299 • Fax: (978) 794-1848 • Watts.com/PureWater
Canada: Tel: (905) 332-4090 • Fax: (905) 332-7068 • Watts.ca/PureWater
Latin America: Tel: (52) 81-1001-8600 • Watts.com/PureWater