

## Engineering Specification

Job Name \_\_\_\_\_

Contractor \_\_\_\_\_

Job Location \_\_\_\_\_

Approval \_\_\_\_\_

Engineer \_\_\_\_\_

Contractor's P.O. No. \_\_\_\_\_

Approval \_\_\_\_\_

Representative \_\_\_\_\_

# LEAD FREE\*

## Series LF909

### Reduced Pressure Zone Assembly

2½" – 10"

Series LF909 Reduced Pressure Zone assembly is designed to provide cross-connection control protection of the potable water supply in accordance with national plumbing codes. This series can be used in a variety of installations, including health hazard cross-connections in plumbing systems or for containment at the service line entrance. With its exclusive relief valve design incorporating the "air-in/water-out" principle, the series provides substantially improved relief valve discharge performance during the emergency conditions of combined backsiphonage and backpressure with both checks fouled. The iron components of the backflow preventer are coated with ArmorTek®, a patented three-part advanced epoxy system engineered to reduce microbial-induced corrosion (MIC) and protect exposed metal substrate. Series LF909 features Lead Free\* construction to comply with Lead Free\* installation requirements.

The series includes a flood sensor to detect excessive water discharges from the relief valve. The sensor is installed on the assembly exterior and does not alter assembly functions or certifications. The sensor relays a signal that triggers notification to facility personnel for corrective action, thus limiting flooding and costly damage.

#### NOTICE

An add-on connection kit is required to activate the flood sensor. Without the connection kit, the sensor is a passive component that has no communication with any other device. (For more information download RP/IS-909/909RPDA.)

#### Features

- Replaceable seats
- Stainless steel internal parts
- No special tools required for servicing
- Captured spring check assemblies
- Fused epoxy coated and lined checks
- ArmorTek coating technology to resist corrosion of internals
- Industrial-strength sensing hose
- Field reversible relief valve
- Air-in/water-out relief valve design provides maximum capacity during emergency conditions
- Sensor on relief valve for flood detection
- Flood alerts feature activated with add-on sensor connection kit, compatible with BMS and cellular network communication

\*The wetted surface of this product contacted by consumable water contains less than 0.25% of lead by weight.

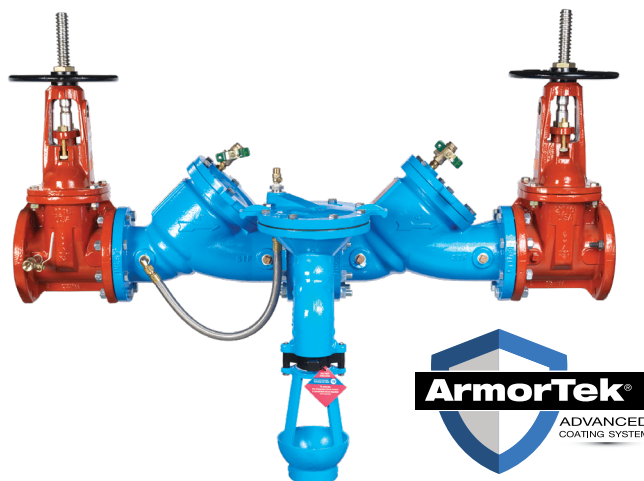

LF909 with flood sensor and air gap

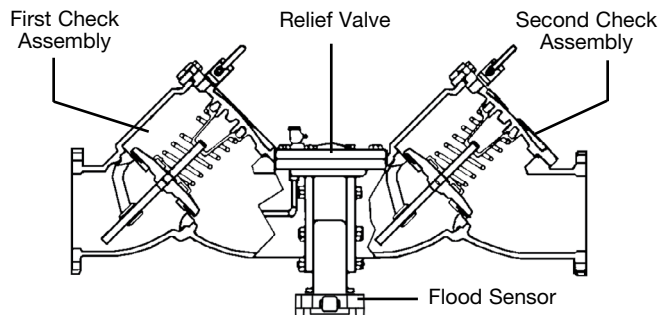

#### NOTICE

Use of the flood sensor does not replace the need to comply with all required instructions, codes, and regulations related to installation, operation, and maintenance of this product, including the need to provide proper drainage in the event of a discharge.

Watts is not responsible for the failure of alerts due to connectivity issues, power outages, or improper installation.

#### NOTICE

The information contained herein is not intended to replace the full product installation and safety information available or the experience of a trained product installer. You are required to thoroughly read all installation instructions and product safety information before beginning the installation of this product.

Inquire with governing authorities for local installation requirements.

## Specification

A Reduced Pressure Zone assembly shall be installed at each cross-connection to prevent backsiphonage and backpressure backflow of hazardous materials into the potable water supply. The assembly shall consist of a pressure differential relief valve located in a zone between two positive seating check valves and captured springs. Backsiphonage protection shall include provision to admit air directly into the reduced pressure zone via a separate channel from the water discharge channel. The assembly shall include two tightly closing shutoff valves before and after the valve and test cocks. The Lead Free\* Reduced Pressure Zone Assembly shall comply with state codes and standards, where applicable, requiring reduced lead content. The assembly shall meet the requirements of ASSE Std. 1013; AWWA Std. C511-92; CSA B64.5; and UL Classified File No. EX3185. Listed by IAPMO (UPC). Approved by the Foundation for Cross-Connection Control and Hydraulic Research at the University of Southern California. Iron components of the backflow preventer shall incorporate ArmorTek coating technology, delivering integrated protection against electrochemical corrosion and microbial-induced corrosion. The assembly shall be a Watts Series LF909, and shall include a sensor on the relief valve for flood detection.

## Model/Option

LF	Without shutoff valves
NRS	Non-rising stem resilient seated gate valves
OSY	UL Classified/FM Approved outside stem-and-yoke resilient seated gate valves
S-FDA	FDA epoxy coated strainer
FS	Flood sensor on relief valve for flood detection

## Materials

Check Valve Body:	Cast iron
Coating:	ArmorTek powder coating, applied to internal and external surfaces
Seat:	Stainless steel
Trim:	Stainless steel
Relief Valve Body:	2½" to 3" Lead Free* cast copper silicon alloy 4" to 10" Cast iron
Test Cock:	Lead Free* copper silicon alloy

## Pressure — Temperature

Temperature Range:	33°F to 110°F (0.5°C to 43°C) continuous, 140°F (60°C) intermittent
Maximum Working Pressure:	175 psi (12.06 bar)

## Standards

AWWA C511-92  
IAPMO PS 31, SBCCI (Standard Plumbing Code)  
USC manual for Cross-Connection Control, 8th Edition

## Approvals



Approved by the Foundation for Cross-Connection Control and Hydraulic Research at the University of Southern California.

## How It Operates

The unique relief valve construction incorporates two channels: one for air, the other for water. When the relief valve opens, as in the accompanying air-in/water-out diagram, the right-hand channel admits air to the top of the reduced pressure zone, relieving the zone vacuum. The channel on the left then drains the zone to atmosphere. Therefore, if both check valves foul, and simultaneous negative supply and positive backpressure develop, the relief valve uses the air-in/water-out principle to stop potential backflow.

### NOTICE

The installation of a drain line is recommended. When installing a drain line, an air gap is necessary.

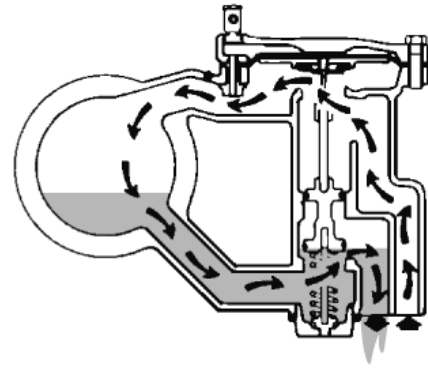

Water Air  
Out In

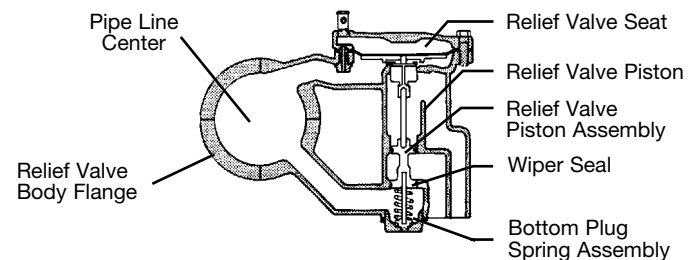

## Dimensions — Weights

The valve can be furnished with two OSY or two NRS shutoffs. The relief valve section is furnished standardly and reversible for implementation on either side.

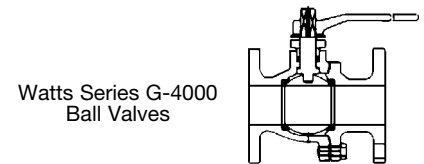
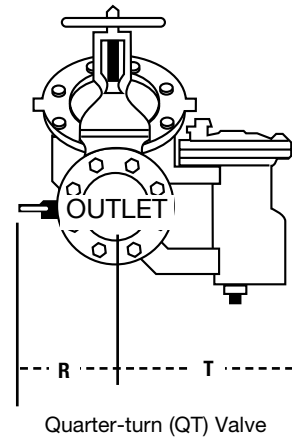
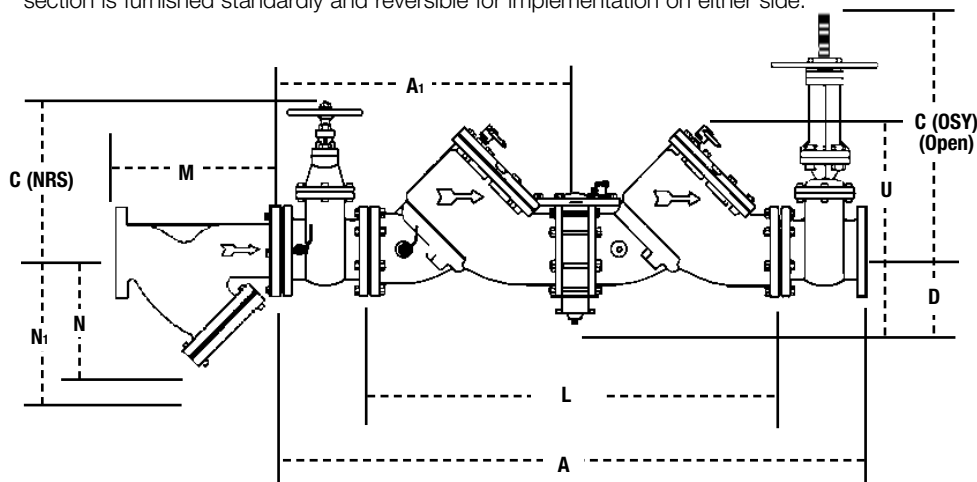

SIZE		DIMENSIONS														WEIGHT										
in.	in.	mm	A1		C clearance for check				D		L		U		R		R (QT)		T		NRS		OSY		QT	
			in.	mm	in.	mm	in.	mm	in.	mm	in.	mm	in.	mm	in.	mm	in.	mm	in.	mm	lb	kg	lb	kg	lb	kg
2½	41½	1053	20¾	527	16¾	416	9¾	238	5¼	133	26⅝	669	11	279	4	102	16	406	9⅛	230	195	88.4	198	89.8	182	82.6
3	42½	1079	21¼	539	18⅞	479	10¼	260	5¼	133	26⅝	669	11	279	5	127	16	406	9⅛	230	225	102	230	104	190	86
4	55⅙	1405	27⅜	702	22¾	578	12¾	310	6	152	37⅞	944	14	356	6	152	19¾	502	14⅞	365	455	206	470	213	352	160
6	65⅙	1672	33	836	30⅞	765	16	406	6	152	44⅛	1134	16	406	11	279	26	660	14⅞	365	718	326	798	362	762	346
8	78⅙	1995	39⅞	998	37¾	959	19⅝	506	9¾	248	55⅙	1404	21	533	11¼	286	11¼	286	19¼	489	1350	612	1456	660	2286	1037
10	93⅙	2376	46¾	1188	45¾	1162	23⅜	605	9¾	248	67⅙	1709	21	533	12½	318	12½	318	21	533	2160	980	2230	1011	3716	1685

\*UL Classified/FM Approved backflow preventers must include UL Classified/FM Approved OSY gate valves.

## Strainer Dimensions

SIZE		DIMENSIONS				WEIGHT			
in.	in.	M		N1†		N		lb	kg
		in.	mm	in.	mm	in.	mm		
2½	10	254	10	254	6½	165	28	12.7	
3	10⅞	257	10	254	7	178	34	15.4	
4	12⅞	308	12	305	8¼	210	60	27	
6	18½	470	20	508	13½	343	133	60	
8	21⅞	549	22¾	578	15½	394	247	112	
10	26	660	28	711	18½	470	370	168	

† Dimension required for screen removal.

## Air Gap Dimensions

When installing a drain line on Series 909 backflow preventers that are installed horizontally, use Series 909 AG air gaps. For flange size backflow preventers installed vertically (flow down), a fabricated air gap is recommended.

IRON BODY		ORDERING		ASSEMBLY		DIMENSIONS				WEIGHT	
Model	Code	Size & Series		A		B		C		lb	kg
		in.	mm	in.	mm	in.	mm	in.	mm		
909AG-F	881378	1¼" – 3"	009/909	4¾	111	6¾	171	2	51	3.25	1.47
		1¼" – 2"	009 M1								
		2"	009 M2								
909AG-K	881385	4" – 6"	909	6⅞	162	9⅞	244	3	76	6.25	2.83
		8" – 10"	909 M1								
909AG-M	881387	8" – 10"	909	7⅞	187	11¼	286	4	102	15.5	7.03

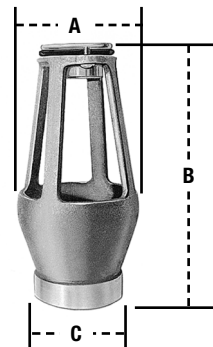

# Capacity

\*Typical maximum flow rate (7.5 ft/s)

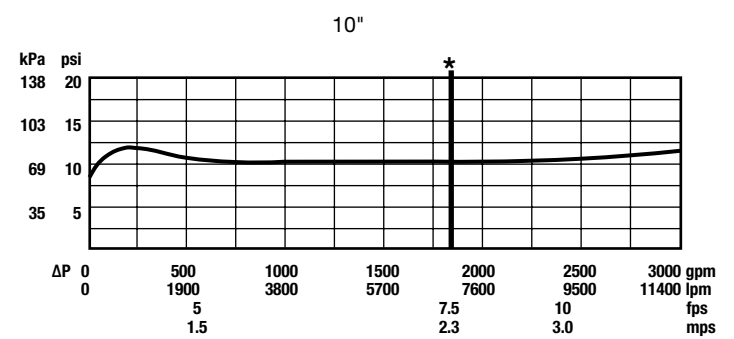
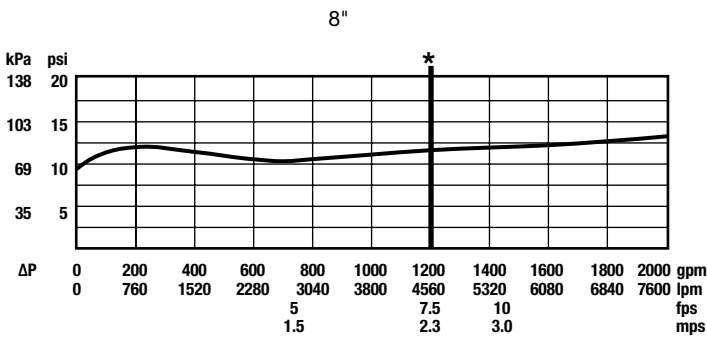
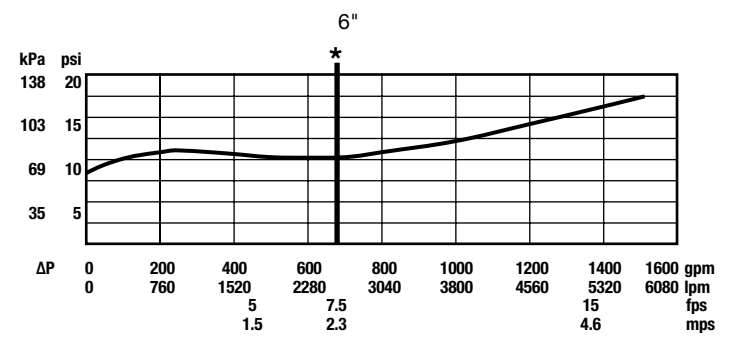
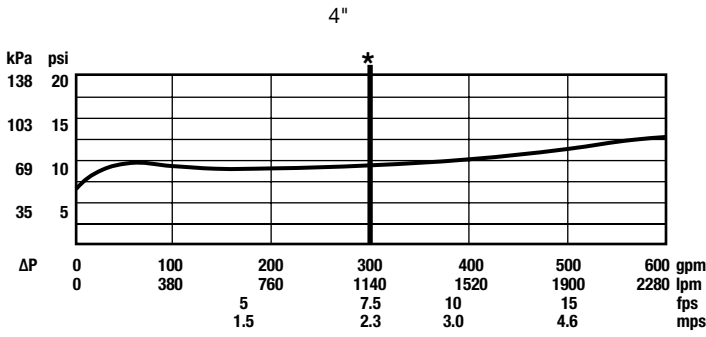
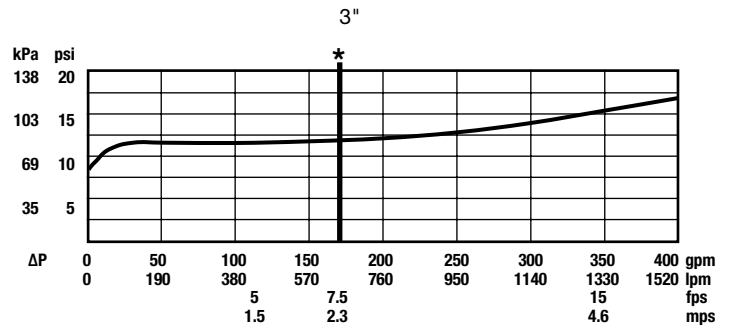
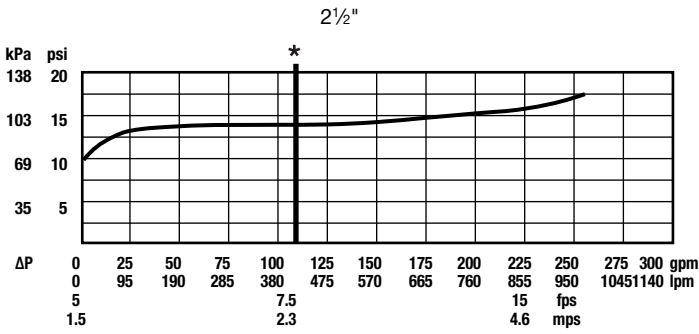

USA: T: (978) 689-6066 • Watts.com  
 Canada: T: (888) 208-8927 • Watts.ca  
 Latin America: T: (62) 55-4122-0138 • Watts.com