

# Installation, Operation, and Maintenance Manual

## MasterSeries® 860, 880V

### Reduced Pressure Assembly

2½" – 10"

#### ⚠ WARNING



Read this Manual **BEFORE** using this equipment. Failure to read and follow all safety and use information can result in death, serious personal injury, property damage, or damage to the equipment. Keep this Manual for future reference.



#### ⚠ WARNING

Local building or plumbing codes may require modifications to the information provided. You are required to consult the local building and plumbing codes prior to installation. If the information provided here is not consistent with local building or plumbing codes, the local codes should be followed. This product must be installed by a licensed contractor in accordance with local codes and ordinances.

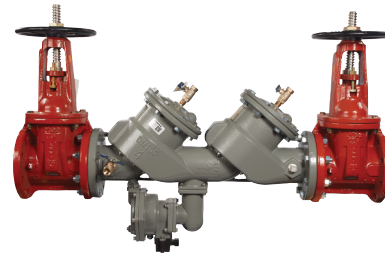
#### ⚠ WARNING

**Need for Periodic Inspection/Maintenance:** This product must be tested periodically in compliance with local codes, but at least once per year or more as service conditions warrant. All products must be retested once maintenance has been performed. Corrosive water conditions and/or unauthorized adjustments or repair could render the product ineffective for the service intended. Regular checking and cleaning of the product's internal and external components helps assure maximum life and proper product function.

#### NOTICE

If an assembly is recommended where installation may be problematic, the assembly must be protected and secured. Remove the handles of shutoff valves to discourage tampering, or install a protective enclosure to discourage vandals. When opting for an enclosure, install the protective cover so that adequate clearance is available for maintenance and testing. Consult local codes before installing any type of protective enclosure.

MasterSeries valve assemblies are designed to protect drinking water supplies from dangerous cross-connections in accordance with national plumbing codes and water authority requirements for non-potable service applications. The Lead Free series are used in potable drinking water systems where code mandates protection from backpressure and backsiphonage conditions. Iron components of the backflow preventer are coated with ArmorTek®, a patented three-part advanced epoxy system engineered to reduce microbial-induced corrosion (MIC) and protect exposed metal substrate. LF860, LF866, LF880V, LF880W/WZ, LF886V, and LF886W/WZ each include a flood sensor on the relief valve to detect excessive discharge. With activation through an add-on connection kit, the sensor relays a signal that triggers a potential flooding alert to select personnel.



LF860 with flood sensor



LF880V with flood sensor  
Standard Configuration



LF880WZ  
Vertical Configuration

#### NOTICE

An add-on connection kit is required to activate the flood sensor. Without the connection kit, the flood sensor is a passive component and has no communication with any other device. (A retrofit sensor connection kit is also available for existing installations. See "Add-on and Retrofit Sensor Connection Kits," for ordering details.)

#### NOTICE

Use of the flood sensor does not replace the need to comply with all required instructions, codes, and regulations related to installation, operation, and maintenance of this product, including the need to provide proper drainage in the event of a discharge.

Watts® is not responsible for the failure of alerts due to connectivity or power issues.

## Contents

How It Operates . . . . .	2
Vandalism Protection . . . . .	3
Freeze Protection . . . . .	3
General Service Guidelines . . . . .	4
Service Procedures . . . . .	4
Testing . . . . .	6
Troubleshooting . . . . .	7
Cross-sectional Views . . . . .	9
Parts List . . . . .	11
Repair Kits . . . . .	13
Add-on and Retrofit Sensor Connection Kits . . . . .	15



A WATTS Brand

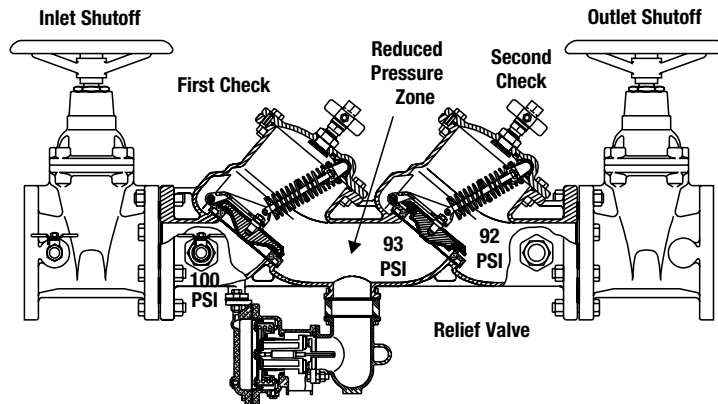
# How It Operates

FEBCO Reduced Pressure Backflow Preventer assemblies consist of two independently operating, spring-loaded check valves with a pressure differential relief valve located between the two checks. The pressure drop across the first check valve is approximately 7.0 psid with no flow. The relief valve consists of a hydraulically balanced diaphragm with the high pressure side hydraulically connected to the upstream side of the first check. The low pressure side is hydraulically connected to the reduced pressure zone; the relief valve remains closed during normal operation. The low pressure side of the diaphragm is spring loaded to force the relief valve open when the pressure drop across the first check (and across the diaphragm) reduces to approximately 3.0 psid. A complete assembly includes two shutoff valves and four test cocks.

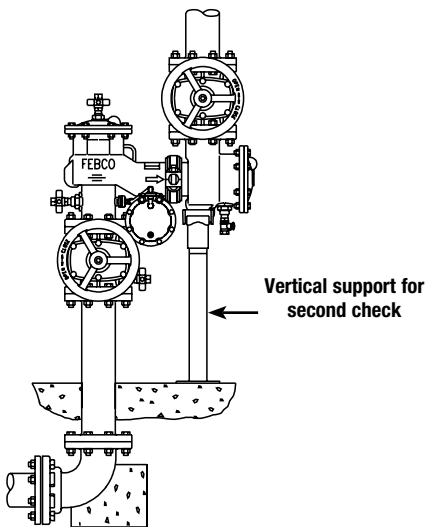
Figures 1, 2, and 3 show typical components and flow passages with corresponding pressure readings (no flow conditions) at the various locations within the assembly with 100 psi line pressure.

**NOTE:**

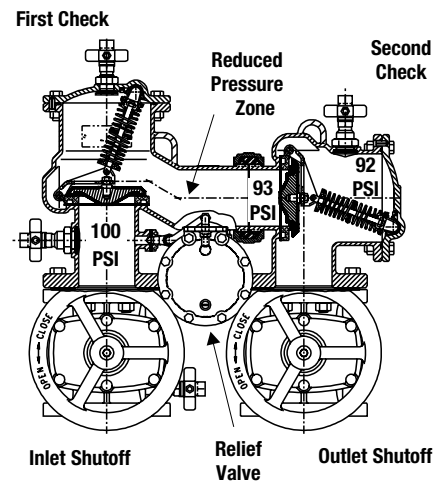
When installed in the vertical orientation, the 880V assembly must include vertical support under the second check body section. (See Figure 2.)



**Figure 1**  
860



**Figure 2**  
880V vertical configuration



**Figure 3**  
880V standard configuration

# Vandalism Protection

If the valve assembly is installed where vandalism is problematic, the assembly must be protected and secured. Consider the following options:

- Remove the handles of shutoff valves to discourage tampering.
- Install a protective enclosure to discourage vandals. When opting for an enclosure, install the protective cover so that adequate clearance is available for maintenance and testing. Consult local codes before installing any type of protective enclosure.
- Loop a chain through both shutoff valve handwheels and locked it into position to prevent tampering.
- For an assembly installed in conjunction with a fire sprinkler system, place a tamper switch on the OS&Y shutoff valves to trigger an alarm if an unauthorized closure occurs.

# Freeze Protection

The valve assemblies may be subject to damage if the internal water is allowed to freeze. Watts recommends that all assemblies be installed with resilient seated shutoffs so that a drip tight closure can be achieved to prevent refilling of the assembly after the freeze protection procedure is performed. The assembly must be protected from freezing using a heated enclosure, insulation using heat tape, or other suitable means. If the system is to be shut down during freezing weather, use the following procedure to drain internal passages.

## Reduced Pressure Zone and Relief Valve Draining

The system requirements include a shutoff valve located upstream of the freeze protection area, and a means for draining upstream of shutoff valve No. 1 and downstream of shutoff valve No. 2.

1. Slowly close the supply valve upstream of the freeze protected area, then open all test cocks on the backflow preventer.

All water within the zone drains to the lowest point of the relief valve discharge port (relief valve seat). A small amount of water remains in the bottom of the main valve body, but is insufficient to cause freeze damage. Leave the test cocks and ball valves in the half-open, half-closed position for the winter.

2. Observe that water drains in this matter per type of valve assembly.

MasterSeries 880 and 880V. All water on the inlet side, and within the zone, drains down to test cock No. 1.

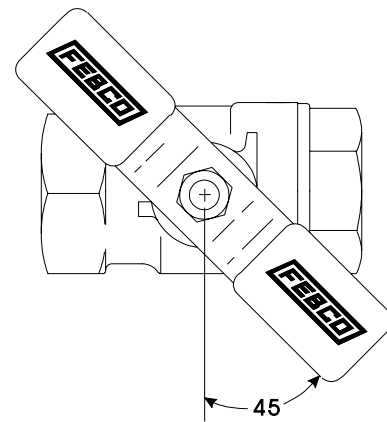
MasterSeries 860. All water drains from the inlet side and the zone.

3. For sizes 2½" – 10", remove both drain plugs from the bottom of the relief valve assembly. Replace the plugs when draining is completed.
4. Drain upstream of shutoff valve No. 1 then downstream of shutoff valve No. 2.
5. Proceed to the procedure for draining each ball valve shutoff.

## Ball Valve Shutoff Draining

NOTE: Assemblies with ball valve shutoffs must also have the shutoff valves drained to prevent freeze damage.

1. After the draining the backflow prevention assembly, position all ball valve shutoffs and test cocks in a half-open, half-closed 45 degree position. (See Figure 4.)
2. Open the ball valve approximately 45 degrees, while draining the pipeline and assembly, to allow water between the ball valve and valve body to drain. Leave the ball valve in this position for the winter to prevent freeze damage.
3. Fully close the ball valves before the system is repressurized. **OPEN AND CLOSE BALL VALVES SLOWLY TO PREVENT DAMAGE TO THE SYSTEM CAUSED BY WATER HAMMER.**



**Figure 4**  
**Ball valve, ½" – 2"**

# General Service Guidelines

- Service the FEBCO assemblies with commonly available tools. The assemblies are designed for ease of maintenance and to be serviced in line. Removal from the line during servicing is unnecessary. No special tools are required.
- Flush the line clean of debris before installing the assembly. The most common cause of check fouling and relief valve discharge is dirt and debris in the seating areas. To flush the line after installation, slowly close the inlet shutoff valve, remove the covers and spring assemblies of both check valves, and open the inlet shutoff valve to allow sufficient flow of water through the assembly to clear all sand, debris, and other matter from the line. If debris in the water continues to cause fouling, a strainer may be installed upstream of the assembly. Check local codes for these requirements.
- Rinse all the parts with clean water before reassembly.
- Carefully inspect diaphragms, seals, and seating surfaces for damage or debris. If the check valve seat disc has been severely cut at the seat ring diameter, the assembly has been subjected to extremely high and repeated backpressure. Either thermal water expansion or water hammer are the most likely causes. If backpressure persists, consider installation of a pressure relief valve downstream of the assembly.
- Use caution to avoid damaging any guiding surfaces while handling parts. Do not force parts together. The O-ring seals used in the assemblies require only a small tightening force to ensure a positive seal.
- Test the assembly after servicing in accordance with the locally approved test method to ensure proper operation.
- See the applicable parts list for identification and the cut-away views for visual aid information.
- Use only the factory-supplied lubricant or fluorosilicone grease.

---

## Service Procedures

NOTE: For the following procedures, see the cross-sectional views (Figures 5 to 10) for location of the numbered items.

### Spring Module Removal

1. Slowly close the outlet shutoff valve and inlet shutoff valve. Bleed residual pressure by opening test cocks No. 4, No. 3, and No. 2 in that order.
2. Remove the cover bolts, taking off last the two bolts located next to the retainer pin, then remove the cover.  
  
NOTE: The spring module is positioned in the body by the cover and is captured.
3. Remove the pivot bearing (item 13) from the upper spring retainer of the spring module. Inspect the pivot bearing and the bearing socket (item 15). A small hole in the bearing socket indicates that replacement is required. Remove the retaining clip (item 5.1) from the groove on one end of the load pin (item 7). Hold the spring module with one hand while sliding out the load pin from the arm (item 4). Lift out the spring module and inspect it for wear or damage. Replace the spring module if necessary.

### Check Disk Removal

Remove the jam nut (item 16) and washer (item 17) from the check disc stem threads. Lift the arm and remove the check disc (item 6). Inspect the sealing surface for debris or damage. Replace the check disc if necessary.

NOTE: When the jam nut is tight, the check disc is designed to wobble.

## Seat Ring Assembly Removal

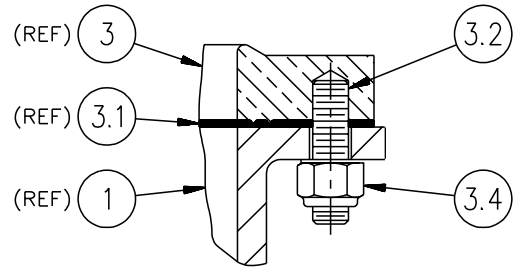
NOTE: Remove the seat ring assembly only if the seat ring (item 3) or the arm (item 4) shows wear or damage.

1. Remove the locknuts (item 3.4).
2. Remove the seat ring assembly.

NOTE: When reassembling, tighten the locknuts from 12 to 15 foot-pounds. If leaking occurs around the bolt, tighten it further until the leaking stops. Do not overtighten.

3. Remove the retaining clip (item 5) from one end of the swing pin (item 4.2). Hold the arm while sliding out the swing pin. Inspect the bushings (item 4.1) and the swing pin for wear or damage. Replace if necessary. Inspect the gasket (item 3.1) for debris and/or damage. Replace if necessary.

NOTE: Reverse this procedure to reassemble the components. The seat ring fits into the body only one way. Check the alignment of the seat ring if the studs don't align with the body holes. The gasket is also nonsymmetric. Both the seat ring and the gasket have a notch that indicates the nonsymmetric hole. Clean all parts thoroughly with clear water before reassembly. Reassemble and bleed test cocks No. 4 and No. 3. Repressurize and test the assembly in accordance with the locally approved test method.



**Figure 5**  
**Seat ring**

## Relief Valve Removal

Remove the cap screws (item 24), washers (item 24.1) and nuts (item 25) at base of relief valve body and hydraulic sensing port. Remove relief valve seat ring (item 34) from bottom of relief valve. Inspect seat ring, seat disc (item 32), and lower guide (item 33) for debris, wear, or damage. Replace as necessary.

## Relief Valve Seat Disc Replacement

1. Separate the relief valve from the elbow and sensing line flange. Remove the cover bolts (item 22) and cover (item 20).
2. Lift out the diaphragm (item 37) and inspect for damage. Replace if necessary.
3. Grasp the spring button (item 28) and pull out the relief valve module.
4. Turn over the relief valve assembly module so that the lower guide (item 33) stem is facing up. Use the tabs on the guide to loosen the guide. Then unscrew the guide and replace the seat disc (item 32).
5. Reassemble the relief valve seat disc in the reverse order.

## Relief Valve Disassembly

1. Remove the O-ring (item 34.1) and the relief valve seat ring (item 34) from the bottom of the relief valve body.
  2. Remove the relief valve cover (item 20) from the relief valve body by removing the 8 cap screws (item 22).
  3. Remove the diaphragm from the relief valve body. Remove the relief valve assembly module from the relief valve body (item 21).
  4. Loosen the tabs on the lower guide (item 33) and remove the lower guide and seat disc (item 32), remove the instruction label from the center of the button, covering the flow screw (item 28.1).
  5. Loosen the flow screw. Remove the spring (item 29) from the main guide (item 31), and remove the flow washer (item 39) from the top of small diaphragm (item 37).
- CAUTION** The spring is captured.
6. Remove the stem (item 30) and the stem washer on end of stem from the diaphragm guide assembly.
  7. Unscrew the retainer from the main guide (item 31) and remove the slip ring (item 38.1) from the retainer.
  8. Remove the small diaphragm from the main guide.

## Relief Valve Assembly

NOTE: Clean all parts thoroughly with clean water before reassembly.

1. Place the small diaphragm (item 37) into the main guide (item 31) with the beaded side of the flange pointed down.
2. Drop the slip ring (item 38.1) into the retainer (item 38) and screw the retainer into the main guide, being careful not to bind the cup shape of the diaphragm.
3. Place the stem washer on the end of stem (item 30) and insert the stem into the diaphragm guide assembly. When the stem is fully inserted, it does not bottom out against diaphragm, so do the following: Press the diaphragm against the stem with thumb and forefinger and slowly pull the stem back out with the diaphragm. Place the stem guide assembly on a flat surface with the diaphragm pointed up.
4. Place the flow washer (item 39) on top of the small diaphragm with slots facing up and with holes lining up. Set the spring (item 29) on the main guide and compress the spring with the button (item 28). With the spring fully compressed, insert and tighten down the flow screw (item 28.1), being careful not to twist the button or assembly which can distort the diaphragm.
5. Stick the instruction label in the center of the button, covering the flow screw. Install the seat disc (item 32) into the stem and install the lower guide (item 33) to retain the disc. Using the tabs on the guide, tighten until the shoulder on the guide contacts the stem.
6. Lubricate the O-ring (item 31.1) with the supplied lubricant and install on the main guide.
7. Install the assembly into the relief valve body (item 21). Place the large diaphragm (item 27), with the cap facing down, into the relief valve body and fold over the stem assembly button. Pull the diaphragm flange up onto the relief valve body flange.
8. Assemble the relief valve cover (item 20) to the relief valve body using the 8 cap screws (item 22) and tighten to 120 inch-pounds torque wrench limit.
9. Insert the relief valve seat ring (item 34) into the bottom of the relief valve body (aligning it with the lower guide and install the O-ring (item 34.1).

N-SHAPE (V) ONLY. Assemble the complete relief valve assembly to the valve body with the O-ring (item 35) and backup ring (item 35.1), using 4 cap screws (item 24), 8 washers (item 24.1), and 4 nuts (item 25). Tighten to 120 inch-pounds torque wrench limit. Attach the sensing line flange cover (item 36). Do not overtighten.

IN-LINE ONLY. Assemble the complete unit to the valve body and elbow. Install the gasket (item 26) with the screen facing the valve body) using 6 cap screws, 12 washers, and 6 nuts. Tighten to 120 inch-pounds torque wrench limit. Do not overtighten.

## Testing

Inspect all mechanical devices on a regular basis to ensure proper operations. Test the assembly at the time of initial installation, after servicing or maintenance, and at least annually thereafter. Acceptable test procedures are published by Foundation for Cross Connection Control and Hydraulic Research at the University of Southern California (USC), American Water Works Association (AWWA), American Society of Sanitary Engineering (ASSE Series 5000), and Canadian Standards Association (CAN/CSA B64.10). Consult the regulatory authority for information specific to the local area.

# Troubleshooting

## Check Procedure with Differential Pressure Gauge

Call customer service if you need assistance with technical details.

CHECKLIST	READING	PROBLEM
Check differential across check valve No. 1	2 to 3 psid	Leak in check valve No. 1 or No. 2
	6 to 8 psid and steady	Malfunctioning pressure relief valve
	2 to 7 psid and fluctuating	Inlet pressure fluctuating
Check differential across check valve No. 1	2 to 3 psid	Check valve No. 1 held open
	6 to 8 psid and steady	Malfunctioning pressure relief valve

## Check Procedure Without Differential Pressure Gauge

CHECKLIST	READING	PROBLEM
Close gate valve No. 2	If discharge stops	Leak in check valve No. 2
	If discharge does not stop	Try the next remedy
Open test cock No. 4 to produce a flow greater than the differential relief valve discharge	If discharge stops	Leak in check valve No. 1
	If discharge does not stop	Malfunctioning pressure relief valve

## Troubleshooting, cont'd.

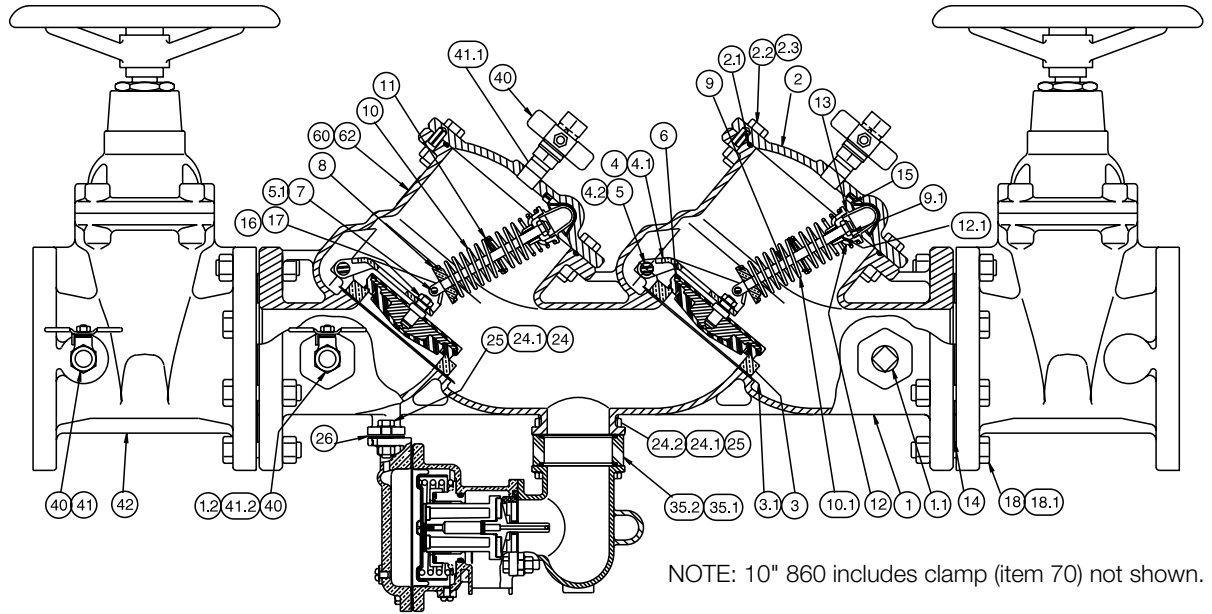
PROBLEM	CAUSE	SOLUTION
<p>Continuous discharge from relief valve during NO-FLOW condition (discharge stops with water flow).</p> <p>With this symptom, the pressure drop across check valve No. 1 would be 2 to 3 psid.</p> <p>If a flow of water (more than the discharge) is created through the valve, the pressure drop should increase to approximately 7 psi.</p>	Debris fouling check valve No. 1.	Inspect and clean.
	Outlet pressure higher than inlet pressure and debris fouling check valve No. 2.	Inspect and clean.
	Spring stem not moving freely.	Inspect for dirt or other foreign material.
	Damaged seat or seat disc.	Inspect and replace.
	Leakage at seal under the seat ring.	Inspect and replace seal.
<p>Intermittent discharge from relief valve during NO-FLOW condition. With this symptom, the pressure drop across the check valve No. 1 would vary from about 2 to 7 psid.</p>	Inlet line pressure variations causing relief valve to discharge.	Eliminate or reduce pressure variations by installing a soft-seated, spring-loaded check on upstream side of device.
	Pressure surges (water hammer) causing relief valve to discharge as pressure wave passes through the zone.	Eliminate or reduce pressure surges.
<p>Continuous discharge from relief valve during FLOW and NO-FLOW conditions.</p> <p>With this symptom, the pressure drop across check valve No. 1 would be 7 psid or more at all times.</p>	Seat disc dislodged from cavity in the main stem (this can be caused by pressure surges during the initial filling of system lines).	Reposition disc in the main stem cavity. Repressurize system slowly.
	Debris fouling the relief valve seat.	Inspect and clean.
	Debris fouling the relief valve sensing passage.	Inspect and clean.
	Dirt or scale jamming the main stem.	Inspect and clean, or replace.
	Leakage at main stem or O-ring/diaphragm.	Inspect and clean, or replace.
<p>Relief valve does not open above 2.0 psid during field testing.</p>	Outlet gate valve not closed completely.	Check for debris blocking gate.
	Plugged low pressure hydraulic passage (from "ZONE" to inner diaphragm).	Inspect and clean.
	Improper alignment of internal parts during reassembly (causing high resistance to movement).	Disassemble and center the button, spring, and main stem, then reassemble.
	Jammed main stem due to debris.	Clean. Clear any debris blocking the gate valve.
<p>First check pressure drop is low (less than 5 psid) during field testing.</p>	Debris fouling the first check seat.	Inspect and clean.
	Debris fouling the second check seat with backpressure.	Inspect and clean.
	Inlet pressure variations causing inaccurate gauge reading.	Eliminate pressure variations. See the second problem listed above.
	Disc does not move freely in arm, causing the disc not to be parallel to the seat ring.	Inspect and clean if required.
	Damaged seat or seat disc.	Inspect and replace as required.
	Worn guide, bushings, or stem.	Inspect and replace as required.
	Bearing not properly seated in cover.	Inspect and reassemble.
<p>Check valve No. 2 fails to hold back pressure during field testing.</p>	Outlet gate valve not closed completely.	Check for debris blocking the gate valve.
	Debris fouling the second check seat.	Inspect for dirt or other foreign debris.
	Disc not moving freely in assembly.	Inspect and clean.
	Damaged seat or seat disc.	Inspect and replace as required.
	Worn guide, bushings, or stem.	Inspect and replace as required.
	Bearing not properly seated in cover.	Inspect and replace if required. Inspect and reassemble.

### NOTICE

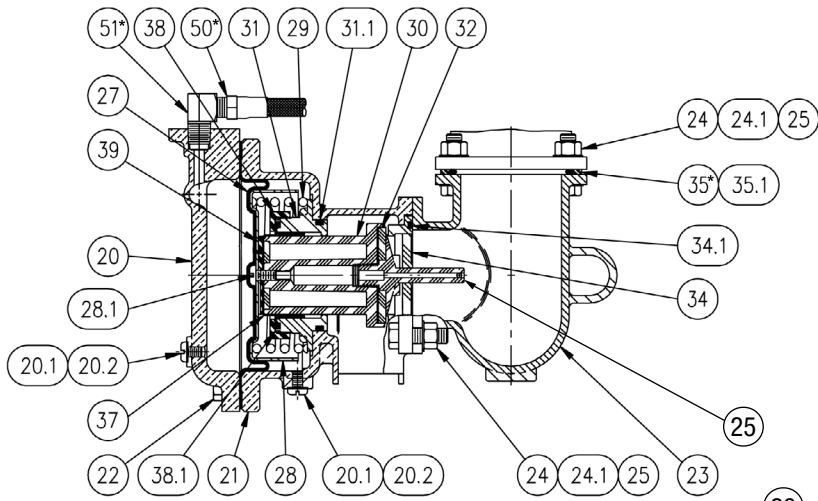
If check valve seat disc has been severely cut at the seat ring diameter, the assembly is being subject to extremely high and repeated back pressure. Either thermal water expansion or water hammer are the most likely causes.

# Cross-Sectional Views

**Figure 6**  
860 Cut-a-way

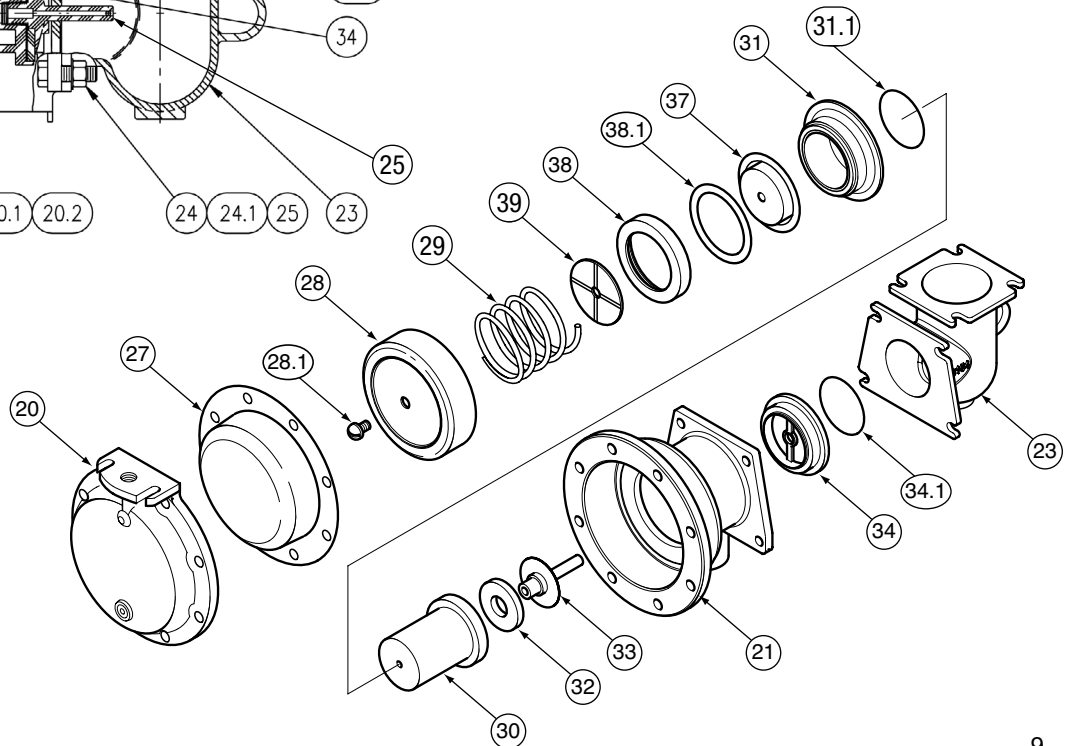


**Figure 7**  
Relief valve cut-a-way

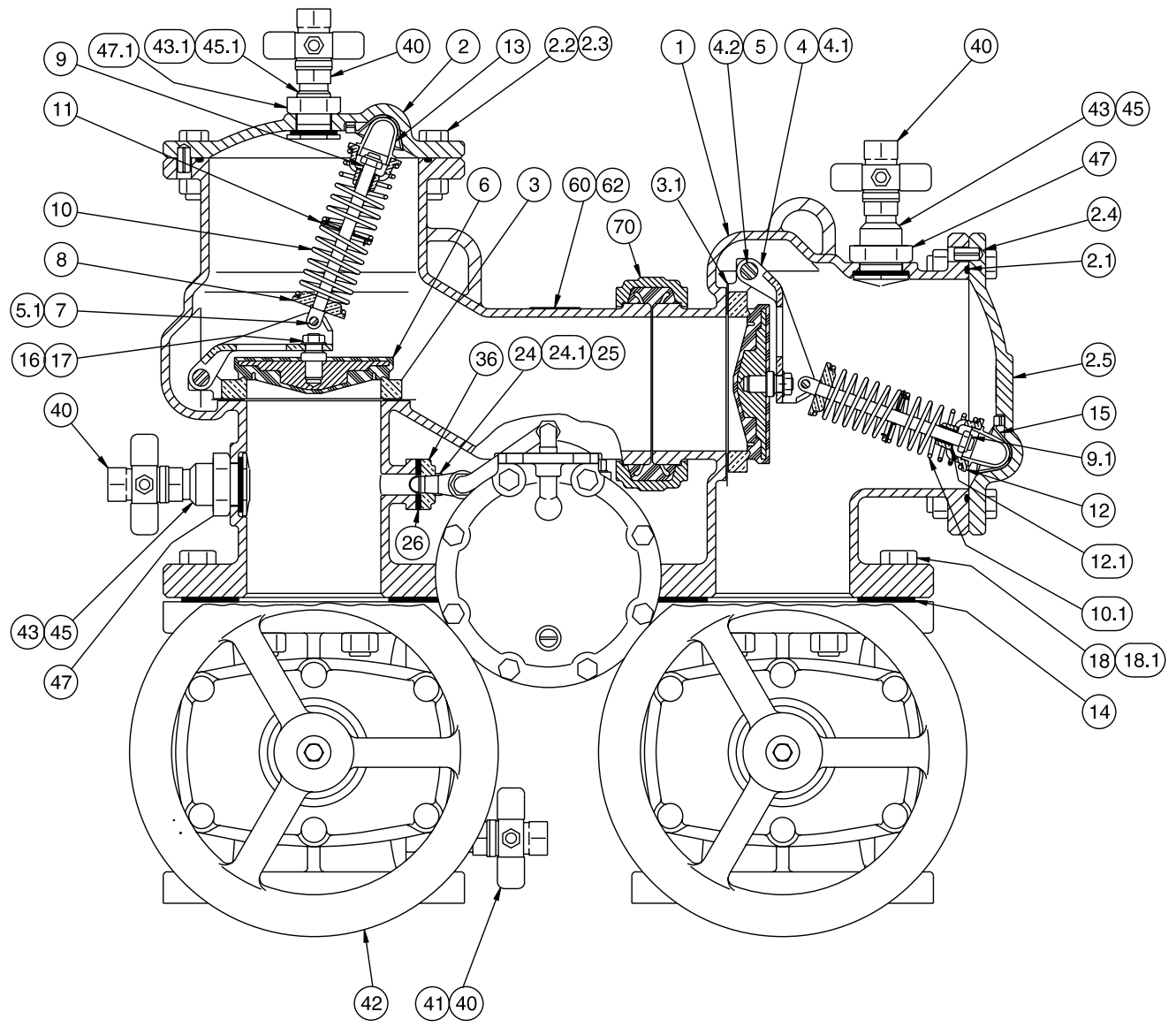


NOTE: 880, 880V only.

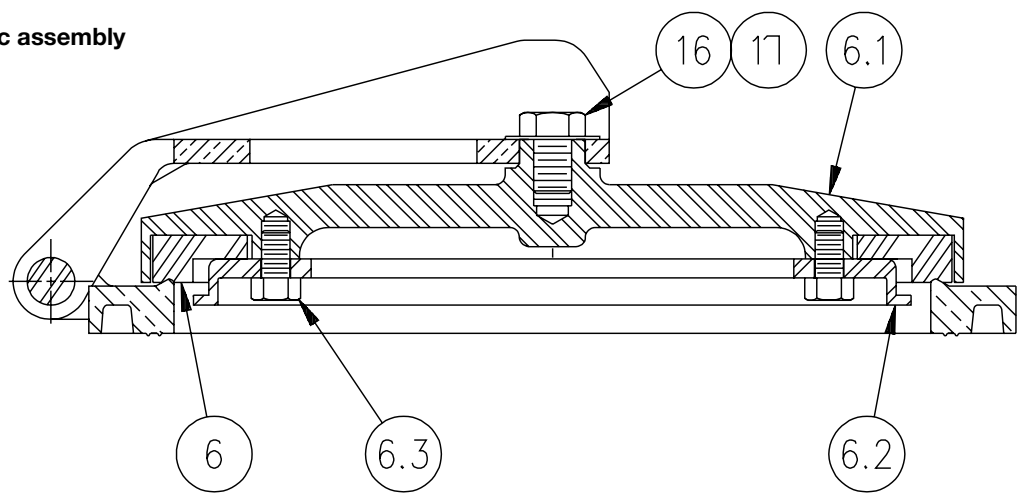
**Figure 8**  
Relief valve exploded view



**Figure 9**  
**880V Cut-a-way**



**Figure 10**  
**880V, Only 10" disc assembly**



# Parts List

ITEM	DESCRIPTION	QUANTITY	2 1/2"	3"	4"	6"	8"	10"
1	Body (860)	1	880-131	880-132	880-133	880-134	880-135	N/A
	Body (880V)	1	880-193	880-194	880-188	880-189	880-190	880-191
1.1	Pipe Plug (860)	1	578-171-50	578-171-50	578-171-50	578-171-50	578-171-50	N/A
1.2	Bushing	1	571-161-54	571-161-54	571-161-54	571-161-54	571-161-54	
2	Cover (860)	2	880-250	880-250	880-251	880-252	880-253	N/A
	Cover 1 <sup>st</sup> Check (880V)	1	880-192	880-192	880-175	880-176	880-177	880-178
2.1	O-ring	2	39625579	39625579	396-261-79	396-269-79	396-276-79	396-279-79
2.2	Capscrew	16	51101614	51101614	511-017-14	511-019-18	511-020-18	511-020-20
2.3	Hex Nut	16	52101600	52101600	521-017-00	521-101-90	521-020-00	521-020-00
2.4	Expansion Pin	2	360-089	360-089	360-089	360-089	360-089	360-089
2.5	Cover 2 <sup>nd</sup> Check (880V)	1	880-106	880-106	880-107	880-108	880-109	880-110
3	Seat Ring	2	110-071	110-071	110-072	101-259	110-074	101-261
3.1	Gasket	2	450-102	450-102	450-106	450-108	450-109	450-110
3.2	Socket Head Screw	8	517-514-10	517-514-10	517-514-10	517-514-10	517-514-10	517-514-12
3.4	Elastic Stop Nut	8	523-514-00	523-514-00	523-514-00	523-514-00	523-514-00	523-514-00
4	Arm	2	101-212	101-212	101-207	101-208	101-210	101-211
4.1	Bushing Swing Pin	4	500-338	500-338	500-338	500-388	500-338	500-337
4.2	Swing Pin	2	240-137	240-137	240-137	240-138	240-139	240-140
5	Retaining Clip	4	740-118	740-118	740-118	740-118	740-118	740-119
5.1	Hairpin Cotter	4	740-120	740-120	740-120	740-120	740-120	740-120
6	Check Disk (860)	2	402-014	402-014	402-006	402-007	402-008	N/A
	Check Disk (880V)	2	402-030	402-030	402-031	402-032	402-008	N/A
	Seat Disk (10"-880V)	2	N/A	N/A	N/A	N/A	N/A	400-145
6.1	Disk Holder (10"-880V)	2	N/A	N/A	N/A	N/A	N/A	190-029
6.2	Disk Retainer (10"-880V)	2	N/A	N/A	N/A	N/A	N/A	190-034
6.3	Capscrew (10"-880V)	6	N/A	N/A	N/A	N/A	N/A	511-515-05
7	Load Pin	2	240-130	240-130	240-130	240-131	240-131	240-132
8	Lwr Spring Retainer	2	101-203	101-203	101-203	101-204	101-204	101-205
9	Spring Stem	2	240-116	240-116	240-117	240-118	240-119	240-120
9.1	Elastic Stop Jam Nut	2	720-054	720-054	720-054	720-055	720-055	720-055
10	Spring 1 <sup>st</sup> Check	2	630-154	630-154	630-155	630-156	630-157	630-158
10.1	Spring 2 <sup>nd</sup> Check	2	630-162	630-162	630-163	630-151	630-164	630-165
10.2	Spring Shim 2 <sup>nd</sup> Check (8")	1	N/A	N/A	N/A	N/A	500-354	N/A
11	Spring Guide	2	360-086	360-086	360-086	360-087	360-087	101-217
12	Upr Spring Retnr	2	101-216	101-216	101-216	101-206	101-206	101-221
12.1	Bushing-Spr. Stem	2	500-344	500-344	500-344	500-345	500-345	500-340
13	Pivot Bearing	2	101-218	101-218	101-218	101-219	101-219	101-220
14	Flange Gasket	2	780-365	780-366	780-367	780-368	780-369	780-370
15	Bearing Socket	2	500-335	500-335	500-335	500-336	500-336	500-336
16	Hex Jam Nut	2	524-515-00	524-515-00	524-515-00	524-517-00	524-517-00	511-517-06
17	Washer	2	360096	360-096	360-096	360-097	360-097	360-097
18	Flange Bolt	( )	(8)511-019-22	(8)511-019-22	(12)511-019-22	(12)511-019-22	(12)511-019-22	(24)511-019-22
18.1	Flange Nut	( )	(8)511-019-22	(8)511-019-22	(20)511-019-22	(20)511-019-22	(20)511-019-22	(24)511-019-22
18.2	Flange Stud	4	N/A	N/A	513-019-26	513-019-26	513-019-26	N/A
20	R.V. Cover	1	110-012	110-012	110-012	110-012	110-012	110-012
20.1	Bleed Screw	2	519-513-03	519-513-03	519-513-03	519-513-03	519-513-03	519-513-03

NOTE: Some items are sold only as part of a repair kit.

## Parts List, cont'd.

ITEM	DESCRIPTION	QUANTITY	2 1/2"	3"	4"	6"	8"	10"
20.2	Gasket	2	340-078	340-078	340-078	340-078	340-078	340-078
21	R.V. Body	1	110-011	110-011	110-011	110-011	110-011	110-011
22	Cover Bolt	8	511-515-08	511-515-08	511-515-08	511-515-08	511-515-08	511-515-08
23	Elbow	1	880-154	880-154	880-154	880-154	880-154	880-154
24	RV Mtg Bolt	4	511-014-10	511-014-10	511-014-10	511-014-10	511-014-10	511-014-10
24.1	Washer - RV	4	360-090	360-090	360-090	360-090	360-090	360-090
24.2	Cap Screw	4	511-014-18	511-014-18	511-014-18	511-014-18	511-014-18	N/A
25	Nut	4	521-014-00	521-014-00	521-014-00	521-014-00	521-014-00	521-014-00
26	Gasket/Strainer	1	450-107	450-107	450-107	450-107	450-107	450-107
27	Lrg. Diaphragm	1	400-108	400-108	400-108	400-108	400-108	400-108
28	Button	1	300-118	300-118	300-118	300-118	300-118	300-118
28.1	Flow Screw	1	240-136	240-136	240-136	240-136	240-136	240-136
29	RV Spring	1	630-168	630-168	630-168	630-168	630-168	630-168
30	Stem - RV	1	500-399	500-399	500-399	500-399	500-399	500-399
31	Main Guide - RV	1	110-013	110-013	110-013	110-013	110-013	110-013
31.1	O-ring - RV	1	396-230-79	396-230-79	396-230-79	396-230-79	396-230-79	396-230-79
32	Seat Disc - RV	1	400-123	400-123	400-123	400-123	400-123	400-123
33	Lower Guide	1	500-342	500-342	500-342	500-342	500-342	500-342
34	Seat Ring	1	110-015	110-015	110-015	110-015	110-015	110-015
34.1	O-ring	1	396-229-79	396-229-79	396-229-79	396-229-79	396-229-79	396-229-79
35	O-ring	2	396-233-79	396-233-79	396-233-79	396-233-79	396-233-79	396-233-79
35.1	Back-Up Ring	1	500-350	500-350	500-350	500-350	500-350	500-350
35.2	Extension	1	500-388	500-388	500-388	500-388	500-388	500-388
36	Adaptor Plate (880V)	1	101-252	101-252	101-252	101-252	101-252	101-252
37	Sm. Diaphragm	1	400-109	400-109	400-109	400-109	400-109	400-109
38	Retainer	1	110-014	110-014	110-014	110-014	110-014	110-014
38.1	Slip Ring	1	340-103	340-103	340-103	340-103	340-103	340-103
39	Flow Washer	1	500-387	500-387	500-387	500-387	500-387	500-387
40	Ball Valve	4	781-047	781-047	781-047	781-048	781-048	781-048
41	Nipple	1	571-181-45	571-181-45	781-181-45	571-181-53	571-181-56	571-181-56
41.1	Nipple (860)	2	571-181-43	571-181-43	571-181-43	571-181-53	571-181-53	N/A
41.2	Nipple (860)	1	571-181-44	571-181-44	571-181-44	571-181-55	571-181-55	N/A
42	Gate Valve (NRS)	2	781-005	781-006	781-007	781-008	781-009	781-010
	Gate Valve (OSY)	2	780-891	780-893	781-895	780-897	780-899	780-901
43	Bulkhead Fitting (880V)	2	110-003	110-003	110-003	101-249	101-249	101-249
43.1	Bulkhead Fitting (880V)	1	101-237	101-237	101-237	101-249	101-249	101-249
45	Gasket (880V)	2	450-105	450-105	450-105	450-105	450-105	450-105
45.1	Gasket (880V)	1	450-104	450-104	450-104	450-105	450-105	450-105
47	Nut (880V)	2	101-251	101-251	101-251	101-251	101-251	101-251
47.1	Nut (880V)	1	101-250	101-250	101-250	N/A	N/A	N/A
50	Sensing Line (880V)	1	781-159	781-159	781-159	781-159	781-159	781-159
51	Street Elbow (880V)	2	200-830	200-830	200-830	200-830	200-830	200-830
60	Identification Plate	1	380-113	380-113	380-113	380-113	380-113	380-113
62	Drive Screw	1	781-224	781-224	781-244	781-224	781-224	781-224
70	Clamp	1	781-179	781-179	781-180	781-181	781-182	781-183

### NOTE:

Some items are sold only as part of a repair kit.

Bulkhead fittings are not furnished on 860.

Item 70 used on 880V (2 1/2"-10") and 860 (10") only.

# Repair Kits

Before contacting the local FEBCO parts distributor, write down the following information to have on hand when placing the order. The serial number located on the assembly ID plate can assist in ordering the proper kit. Some parts are sold only in kit form.

- Item number and name. Locate the number and name of the item in the Parts List section.
- Valve size. Verify the size of the valve that the item is to be used on.
- Model number. Record the full model number from the name plate.
- Kit number. Use the tables below to find the number of the kit containing the item.

KIT DESCRIPTION		2 1/2"	3"	4"	6"	8"	10"
CHECK REPLACEMENT KIT Items 2.1, 3, 3.1, 3.2, 3.4, 4, 4.1, 4.2, 13, 15, 16, 17	860 (inlet)	905-543	905-543	905-546	905-550	905-554	905-554
	860 (outlet)	905-527	905-527	905-547	905-551	905-555	905-555
	880V (inlet)	905-544	905-544	905-548	905-552	905-554	905-556
	880V (outlet)	905-545	905-545	905-549	905-553	905-555	905-557
860/880V RP INLET SPRING MODULE Items 2.1, 5.1, 7, 8, 9, 9.1, 10, 11, 12, 12.1		905-172	905-172	905-173	905-174	905-175	905-176 (860)
							905-175 (860)
860/880V RP OUTLET SPRING MODULE Items 2.1, 5.1, 7, 8, 9, 9.1, 10.1, 10.2, 11, 12, 12.1		905-142	905-142	905-143	905-144	905-145	905-145 (860)
							905-146 (880)
860 DISC ASSEMBLY Items 2.1, 6, 16, 17		905-182	905-182	905-183	905-184	905-185	905-185
880V DISC ASSEMBLY Items 6, 16, 17 - (10" - item 6 only)		905-224	905-224	905-225	905-226	905-185	400-145
SEAT RING / ARM ASSEMBLY Items 3, 3.1, 3.2, 3.3, 3.4, 4, 4.1, 4.2, 5							905-160 (860)
		905-157	905-157	905-158	905-159	905-160	905-161 (880)
860 RUBBER PARTS KIT (CHECKS AND RV) Items 2.1, 3.1, 6, 15, 16, 17, 26, 27, 31.1, 32, 34.1, 35.1, 35.2, 45, 45.1		905-187	905-187	905-188	905-189	905-190	905-190
880V RUBBER KIT (CHECKS AND RV) Items 2.1, 3.1, 6, 15, 16, 17, 26, 27, 31.1, 32, 34.1, 35, 35.1, 37, 45, 45.1		905-227	905-227	905-228	905-229	905-190	905-191
860 RELIEF VALVE REPAIR KIT Items 26, 27, 28, 28.1, 29, 30, 31, 31.1, 32, 33, 34, 34.1, 37, 38, 38.1, 39		905-192	905-192	905-192	905-192	905-192	905-192

NOTE: Item 10.2 for the 860/880V RP outlet spring module applies to 8" assembly only.

## Repair Kits, cont'd.



KIT DESCRIPTION	2 1/2"	3"	4"	6"	8"	10"
880V RELIEF VALVE INTERNAL ASSEMBLY KIT Items 27, 28, 28.1, 29, 30, 31, 31.1, 32, 33, 34, 34.1, 37, 38, 38.1, 39	905-320	905-320	905-320	905-320	905-320	905-320
860 COVER ASSEMBLY BOTH CHECKS (TAPPED)	905376	905376	905377	905378	905379	905379
880V INLET CHECK ONLY  Items 2, 2.1, 15	905-167	905-167	905-168	905-169	905-170	905-170 (860) 905-171 (880)
880V COVER ASSEMBLY OUTLET CHECK ONLY Items 2.1, 2.5, 15  (BLANK)	905-244	905-244	905-245	905-246	905-247	905-248
BULKHEAD FITTINGS ASSEMBLY COVER Items 43.1, 45.1, 46.1, 47.1	905-275	905-275	905-275	-	-	-
BULKHEAD FITTINGS ASSEMBLY BODY Items 43, 45, 46, 47	905-276	905-276	905-276	-	-	-
BULKHEAD FITTINGS ASSEMBLY BODY AND COVER Items 43, 45, 46, 47	-	-	-	905-277	905-277	905-277
BULKHEAD PLUG ASSEMBLY 2ND CHECK COVER (N & V UNITS) EARLY PROD. Items 44, 45.1, 46.1, 47.1	905-278	905-278	905-278	-	-	-
BULKHEAD PLUG ASSEMBLY 2ND CHECK COVER (N & V UNITS) EARLY PROD. Items 44, 45, 46, 47	-	-	-	905-279	905-279	905-279
860 RELIEF VALVE ASSEMBLY Items 24, 24.1, 24.2, 25, 35.1, 35.2, 201	905-294	905-294	905-294	905-294	905-294	905-294
880V RELIEF VALVE ASSEMBLY Items 24, 24.1, 25, 26, 35.1, 36, 50, 51, 201	905-295	905-295	905-295	905-295	905-295	905-295
860 CHECK RUBBER KIT Items 2.1, 3.1, 6, 15, 16, 17, 26, 35.1, 35.2, 45, 45.1	905-409	905-409	905-410	905-411	905-412	905-412
880V CHECK RUBBER KIT Items 2.1, 3.1, 6, 15, 16, 17, 26, 35, 35.1, 45, 45.1	905-413	905-413	905-414	905-415	905-412	905-416
860/880V Relief Valve Rubber Kit Items 26, 27, 31.1, 32, 34.1, 37	905-316	905-316	905-316	905-316	905-316	905-316

**NOTE:**



Some items are sold only as part of a repair kit.  
Bulkhead fittings are not furnished on 860.

# Add-on and Retrofit Sensor Connection Kits

## For Building Management Systems

ORDERING CODE	ADD-ON/RETROFIT KIT	DESCRIPTION
88009414	 <p>FP-FBF-BMS BMS Sensor Connection Kit MasterSeries LF860, LF866, LF880V, LF886V Sizes 2½" to 10"</p>	Includes activation module with cable, ground wire, and power adapter. Use this kit to activate the flood sensor and enable flood detection capabilities on the relief valve of a new installation linked to a BMS controller (not included).
88009415	 <p>FP-RFK-FBF-BMS-CFS BMS Sensor Retrofit Connection Kit MasterSeries LF860, LF866, LF880V, LF886V Sizes 2½" to 10"</p>	Includes flood sensor with mounting hardware, activation module with cable, ground wire, and power adapter. Use this kit to install the flood sensor and enable flood detection capabilities on the relief valve of an existing installation linked to a BMS controller (not included).

## For Cellular Network Communication

ORDERING CODE	ADD-ON/RETROFIT KIT	DESCRIPTION
88009416	 <p>FP-FBF-CFS Cellular Sensor Connection Kit MasterSeries LF860, LF866, LF880V, LF886V Sizes 2½" to 10"</p>	Includes activation module with cable, Cellular Gateway with mounting kit, ground wire, and power adapter. Use this kit to activate the flood sensor and enable flood detection capabilities on the relief valve of a new installation linked to a cellular network to send alerts by email message, SMS text message, or voice call.
88009417	 <p>FP-RFK-FBF-CFS Cellular Sensor Retrofit Connection Kit MasterSeries LF860, LF866, LF880V, LF886V Sizes 2½" to 10"</p>	Includes flood sensor with mounting hardware, activation module with cable, Cellular Gateway with mounting kit, ground wire, and power adapter. Use this kit to install the flood sensor and enable flood detection capabilities on the relief valve of an existing installation linked to a cellular network to send alerts by email message, SMS text message, or voice call.

**Limited Warranty:** FEBCO (the "Company") warrants each product to be free from defects in material and workmanship under normal usage for a period of one year from the date of original shipment. The main valve ductile wall of each product manufactured with the Company's ArmorTek® advanced coating system is warranted against perforations due to microbial-induced corrosion (MIC) under normal usage for a period of eight (8) years from the date of original shipment. In the event of such defects within the warranty period, the Company will, at its option, replace or recondition the product without charge.

**THE WARRANTY SET FORTH HEREIN IS GIVEN EXPRESSLY AND IS THE ONLY WARRANTY GIVEN BY THE COMPANY WITH RESPECT TO THE PRODUCT. THE COMPANY MAKES NO OTHER WARRANTIES, EXPRESS OR IMPLIED. THE COMPANY HEREBY SPECIFICALLY DISCLAIMS ALL OTHER WARRANTIES, EXPRESS OR IMPLIED, INCLUDING BUT NOT LIMITED TO THE IMPLIED WARRANTIES OF MERCHANTABILITY AND FITNESS FOR A PARTICULAR PURPOSE.**

The remedy described in the first paragraph of this warranty shall constitute the sole and exclusive remedy for breach of warranty, and the Company shall not be responsible for any incidental, special or consequential damages, including without limitation, lost profits or the cost of repairing or replacing other property which is damaged if this product does not work properly, other costs resulting from labor charges, delays, vandalism, negligence, fouling caused by foreign material, damage from adverse water conditions, chemical, or any other circumstances over which the Company has no control. This warranty shall be invalidated by any abuse, misuse, misapplication, improper installation or improper maintenance or alteration of the product.

Some States do not allow limitations on how long an implied warranty lasts, and some States do not allow the exclusion or limitation of incidental or consequential damages. Therefore, the above limitations may not apply to you. This Limited Warranty gives you specific legal rights, and you may have other rights that vary from State to State. You should consult applicable state laws to determine your rights. **SO FAR AS IS CONSISTENT WITH APPLICABLE STATE LAW, ANY IMPLIED WARRANTIES THAT MAY NOT BE DISCLAIMED, INCLUDING THE IMPLIED WARRANTIES OF MERCHANTABILITY AND FITNESS FOR A PARTICULAR PURPOSE, ARE LIMITED IN DURATION TO ONE YEAR FROM THE DATE OF ORIGINAL SHIPMENT.**



**A WATTS Brand**

**USA:** T: (800) 767-1234 • FEBCOonline.com

**Canada:** T: (888) 208-8927 • FEBCOonline.ca

**Latin America:** T: (52) 55-4122-0138 • FEBCOonline.com

