

**MAINTENANCE MANUAL INDEX  
DOUBLE CHECK ASSEMBLIES  
MODELS 850 & 850U 1/2" - 2"**

**FEATURES AND OPERATING PROCEDURES**

**VANDALISM**

**GENERAL SERVICE PROCEDURES**

**CUT-A-WAY DRAWING**

**TROUBLE SHOOTING PROCEDURES**

**CHECK MODULE DISASSEMBLY**

**CHECK MODULE SEAL REPLACEMENT**

**CHECK MODULE RE-ASSEMBLY**

**EXPLODED VIEW**

**PARTS LIST**

**REPAIR KITS**

**TESTING**

**FREEZE PROTECTION**

**OTHER FEBCO MASTERSERIES® PRODUCTS**

**WARRANTY**



## TABLE OF CONTENTS

Features and Operating Procedures .....	2
Vandalism .....	2
General Service Procedures .....	3
Cut-A-Way Drawing .....	3
Trouble Shooting Procedures .....	4
Check Module Disassembly .....	4
Check Module Seal Replacement .....	5
Check Module Re-Assembly .....	5
Exploded View .....	6
Parts List .....	7
Repair Kits .....	8
Testing .....	9
Freeze Protection .....	9
Other FEBCO MasterSeries® Products .....	10
Notes Page .....	11
Warranty .....	Back Cover

## FEATURES AND OPERATING PROCEDURES

The **FEBCO Double Check Assembly Backflow Preventer** consists of two independently operating, spring loaded check valves. The pressure drop across the first check valve is approximately 1.0 PSIG with no flow. The pressure drop across the second check valve is also 1.0 PSIG with no flow. A complete assembly includes two shut-off valves and four test cocks.

## VANDALISM

If the unit is installed where vandalism may be a problem, the assembly should be protected and secured. On 1/2" through 2" units the handles of shut-off valves can be removed to discourage tampering.

A protective enclosure can be installed over the unit to discourage vandals. If an enclosure is used, it should be installed so that adequate clearance is available for maintenance and testing. Consult local codes before installing any type of protective enclosure.

## GENERAL SERVICE PROCEDURES

1. FEBCO backflow prevention assemblies can be serviced with standard tools and are designed for ease of maintenance. The assemblies are designed to be serviced in line, so the unit should not need to be removed from the line during servicing. **NO special tools are required.**

### Suggested Tool Kit Model 850 (1/2" - 2")

- 1 crescent wrench
  - 1 medium standard screw driver
  - Differential pressure test kit
  - 1 medium Phillips screw driver
  - Box/open end wrench
2. The most common cause of check fouling is dirt and debris in the seating areas. The line should be flushed clean of debris before installation of the assembly. To flush the line after installation of the assembly, slowly close the inlet shut-off valve, remove the cover and spring assemblies of both check valves and open the inlet shut-off valve to allow sufficient flow of water through the assembly to clear all sand, debris, etc. from the line. If debris in the water continues to cause fouling, a strainer may be installed upstream of the assembly (check local codes).
  3. Rinse all parts with clean water before reassembly.
  4. Carefully inspect seals, and seating surfaces for damage or debris. If the check valve seat disc has been severely cut at the seat ring diameter, the assembly has been subjected to extremely high and repeated back pressure. Either thermal water expansion or water hammer are the most likely causes. If back pressure persists, consider installation of a pressure relief valve downstream of the assembly.
  5. Use caution to avoid damaging any guiding surfaces while handling parts. Do not force parts together. The o-ring seals used in FEBCO assemblies require only a small tightening force to insure a positive seal.
  6. Test unit after servicing in accordance with locally approved test methods to insure proper operation (see page 9 for more details).
  7. Refer to applicable exploded drawings and parts lists (pages 6-8) for visual aid information.
  8. Use food grade petroleum jelly as a lubricant as instructed in this manual.

## CUT-A-WAY DRAWING

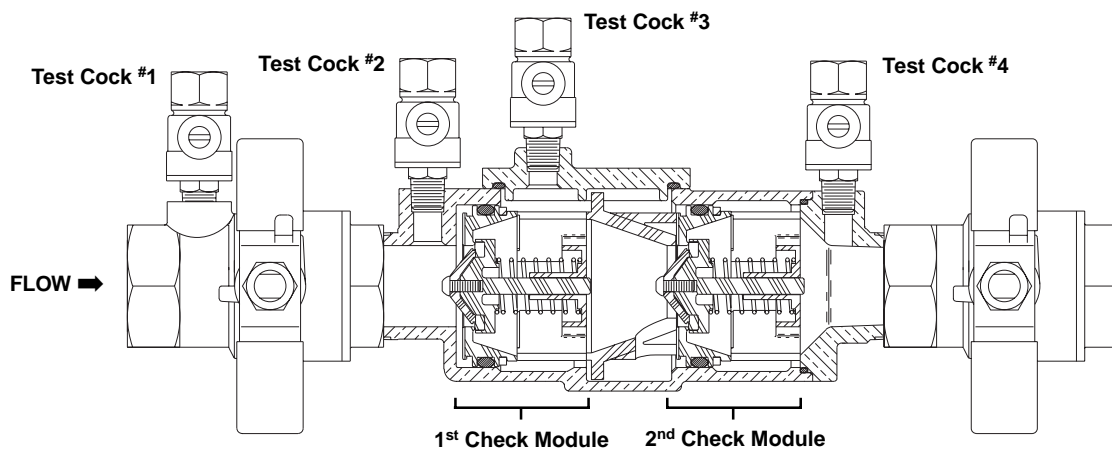

Note: Union End Ball Valves Not Shown

## TROUBLE SHOOTING GUIDE

Symptom #1	Cause:	Solution:
Check fails to hold 1.0 PSID min.	A. Debris on sealing surfaces	Inspect and clean
	B. Leaking shut-off valve	Inspect and clean, or repair
	C. Damaged seat or seat disc	Disassemble and replace
	D. Spring stem not moving freely	Inspect for debris or damage

Symptom #2	Cause:	Solution:
Chatter during flow conditions.	A. Worn or damaged parts	Inspect and replace

Symptom #3	Cause:	Solution:
Low flows passing through the mainline valve.	A. Mainline check fouled	Inspect and clean, or repair

## CHECK MODULE DISASSEMBLY

1. Slowly close inlet and outlet ball valves. Bleed residual pressure by opening #2, #3, and #4 test cocks. Allow the test cocks to remain open until the reassembling is completed. Test cock #1 should remain closed.
2. Remove the cover bolts (item 21) using the appropriate size wrench.
3. Remove spacer (item 8) by grasping the flanged end of the spacer and pulling straight up.
4. Remove the inlet check assembly by pulling it in the direction of flow out from the body bore until it is completely exposed then lift out of the body.
5. Remove the outlet check assembly by placing the tip of a medium size flat nose screw driver in the slot of the seat (item 3) and prying the check assembly back until the red o-ring (item 3.1) is exposed. Then, using your fingers, pull it out from the body bore until it is completely exposed then lift out of the body.

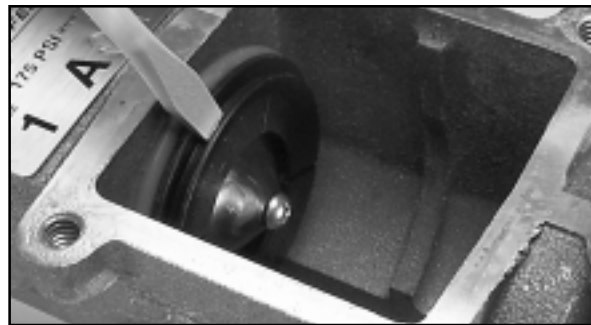
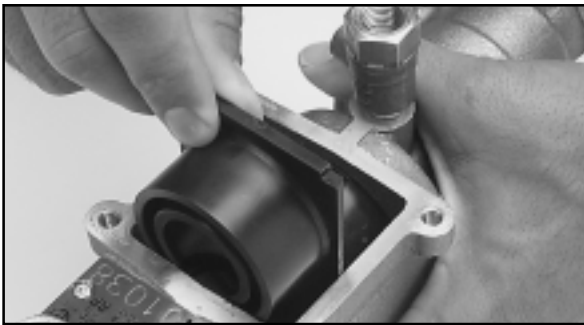

4. Remove the inlet check assembly by pulling it in the direction of flow out from the body bore until it is completely exposed then lift out of the body.

## SEAL REPLACEMENT

Both check assemblies are disassembled and reassembled in the same manner. To service the checks you may replace the check modules with new ones by using check module assembly kits available from FEBCO. Or, you may also replace the rubber components in the check modules by using the replacement rubber parts kits available from FEBCO. For details on parts and kits please see pages 6 - 8.

1. To disassemble, grasp the seat section (item 3) in one hand and the guide section (item 7) in the other hand and then rotate in a counter clock wise direction (approx.  $\frac{1}{8}$  turn) until the two parts disengage.



2. Remove retaining screw (item 5.2) and disc retainer (item 5.1) so the rubber disc is fully exposed. Carefully pry out the rubber disc from poppet. Be careful not to damage the poppet when removing the disc. Rinse poppet in clean water and replace the old rubber disc with new rubber disc. If the rubber disc is not damaged it can be reversed and reinstalled when a new disc is not available. Rinse all other internal components with clean water. Replace disc retainer and secure with retaining screw (item 5.2).



3. Reassemble check module in the reverse manner as indicated in above. When reassembling the check module be sure to insert the poppet stem into the guide hole and keep fingers clear of the slots in the module.

## CHECK MODULE RE-ASSEMBLY

Use reverse procedure for assembly with the following special instructions.

1. Inspect the check module o-ring (item 3.1) for damage and replace if necessary. To ease assembly, apply a thin coating of FEBCO factory supplied petroleum jelly (food grade) to the o-ring (item 3.1) prior to installing in body. **CAUTION:** Excess lubricant may cause foreign debris to collect on internal components which could foul the check assembly and result in a test failure.
2. The word **INLET** is inscribed on the end of each module. That end should face the inlet of the valve.



3. When replacing spacer (item 8) between the two check assemblies be sure that the flanged end of the spacer is touching the back side of the inlet check assembly so that the cover will fit properly. Next, replace cover making sure #3 test cock is on the upstream side. Do not over tighten cover bolts (Approximately 35 inch-pounds is sufficient).
4. After reassembling, close test cock #2, #3 and #4 (test cock #1 should already be closed), slowly open inlet ball valve. Bleed air from the unit by opening and closing test cock #2, then #3 and finally #4.
5. Check for external leaks and repair if necessary. Slowly open outlet ball valve.
6. Test assembly in accordance with the locally approved test methods.

**EXPLODED VIEW**

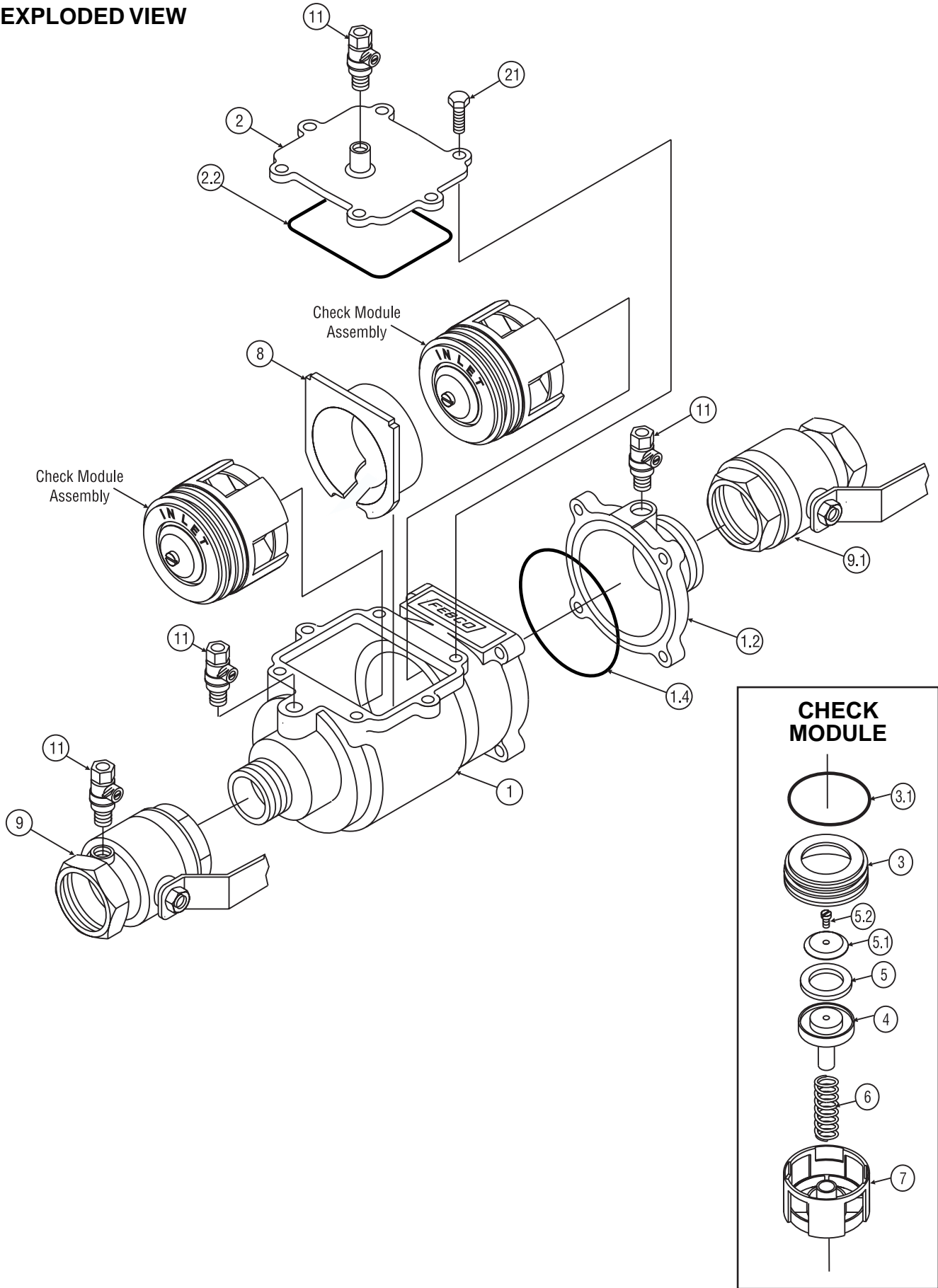

## PARTS LIST

Item	Description	Qty.	1/2	3/4	1	1 1/4	1 1/2	2
1	Body	1	110134	110031	110032	110136	110027	110025
1.2	Tailpiece	1	110127	110040	110039	110138	110138	110037
1.4	O-Ring	1	39603070	39603070	39603370	39604370	39604370	39604370
2	Cover	1	110041	110041	110035	110026	110026	110026
2.2	O-Ring	1	39622470	39622470	39622970	39624070	39624070	39624070
3	Seat	2	500393	500393	500373	500358	500358	500358
3.1	O-Ring	2	39612670	39612670	39622470	39633770	39633770	39633770
4	Poppet	2	500394	500394	500374	500357	500357	500357
5	Seat Disc	2	410127	410127	410134	410128	410128	410128
5.1	Disc Retainer	2	500396	500396	500391	500384	500384	500384
5.2	Round HD Screw	2	51653203	51653203	51653203	51951304	51951304	51951304
6	Spring	1	630177	630177	630173	630169	630169	630169
7	Guide	2	500395	500395	500375	500356	500356	500356
8	Retainer Spacer	1	500392	500392	500376	500366	500366	500366
9*	Ball Valve Tapped	1	781244	781053	781054	781055	781056	781057
	Union End BV Tapped	1	781287	781288	781289	781290	781291	781292
9.1*	Ball Valve	1	781047	781048	781049	781050	781051	781052
	Union End Ball Valve	1	781293	781294	781295	781296	781297	781298
11	Test Cock	4	781074	781074	781074	781075	781075	781075
12	Seat Ring - RV	1	500378	500378	500378	500368	500368	500368
21	Hex HD Capscrew	10	51151306	51151306	51151306	51151406	51151406	51151406

\*Union End Ball Valve Not Shown.

## REPAIR KITS

### How to order parts and Repair Kits

1. Locate item number and kit number in this maintenance manual.
2. Verify the size of the valve the parts are to be used on.
3. Provide full model number located on I.D. plate.
4. Give kit number.
5. A serial number (located on the I.D. plate) will assist in ordering the proper kits.
6. Contact your local FEBCO Parts Distributor.

850 Rubber Parts Kit		1/2	3/4	1	1 1/4	1 1/2	2
Part No.		905-342	905-342	905-343	905-344	905-344	905-344
<b>All Sizes Include:</b>							
Item	Description	Qty.	Item	Description	Qty.		
2.2	O-Ring	1	5	Seat Disc	2		
3.1	O-Ring	2					

850 Check Module Assembly		1/2	3/4	1	1 1/4	1 1/2	2
Part No.		905-347	905-347	905-349	905-351	905-351	905-351
<b>All Sizes Include:</b>							
Item	Description	Qty.	Item	Description	Qty.		
3	Seat	1	5.1	Disc Retainer	1		
3.1	O-Ring	1	5.2	Round HD Screw	1		
4	Poppet	1	6	Spring	1		
5	Seat Disc	1	7	Guide	1		

850 Single Poppet Kit		1/2	3/4	1	1 1/4	1 1/2	2
Part No.		905-339	905-339	905-340	905-341	905-341	905-341
<b>All Sizes Include:</b>							
Item	Description	Qty.	Item	Description	Qty.		
4	Poppet	1	5.1	Disc Retainer	1		
5	Seat Disc	1	5.2	Round HD Screw	1		



## TESTING

All mechanical devices should be inspected on a regular basis to ensure they are working correctly. The assembly should be tested at time of initial installation, after servicing or maintenance, and at least annually thereafter. Acceptable test procedures are published by Foundation for Cross Connection Control and Hydraulic Research at the University of Southern California (USC), The American Water Works Association (AWWA), The American Society of Sanitary Engineering (ASSE Series 5000) and the Canadian Standards Association (CAN/CSA B64•10). Please consult the regulatory authority in your area for more specific information.

---

## FREEZE PROTECTION

The backflow prevention assembly may be subject to damage if the internal water is allowed to freeze. The unit must be protected from freezing using a heated enclosure, insulation heat tape, or other suitable means. The unit must always be accessible for testing and maintenance. If the system will be shut down during freezing weather, use the following procedures to drain internal passages.

### Ball Valve Shut-Off Draining Procedure

If the assembly has been installed with ball valve shut-off valves, they must also be properly drained to prevent freeze damage. After draining procedure has been completed on the backflow prevention assembly, position all ball valve shut-offs and test cocks in a half open/half closed (45 degree) position.

Open the ball valve approximately 45 degrees while draining the pipeline and assembly to allow water between the ball valve and valve body to drain. Leave the ball valve in this position for the winter to prevent freeze damage.

The ball valve must be fully closed before the system is repressurized. **OPEN AND CLOSE BALL VALVES SLOWLY TO PREVENT DAMAGE TO THE SYSTEM CAUSED BY WATER HAMMER.**

### Main Valve Draining Procedure (1/2" - 2")

1. Close the main shut-off valve.
2. Open the inlet drain.
3. Open the inlet and outlet ball valves 45 degree (half open, half closed).
4. Open all testcocks.
5. Open the outlet drain.
6. Remove the cover and inlet check module until all water inside valve drains back out through inlet drain.
7. If you *blowout* the piping downstream of the backflow assembly using compressed air: Connect the air supply to the outlet drain and close the outlet ball valve. After clearing the system with air, partially open the outlet ball valve. Leave all drain valves, testcocks, and ball valves in half open/half closed position for the winter.

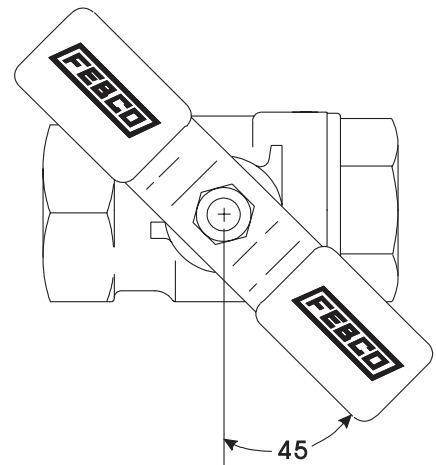

# FEBCO PERFORMANCE, VALUE, AND QUALITY

## FEBCO MasterSeries® (2½" - 10")

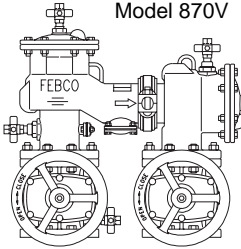
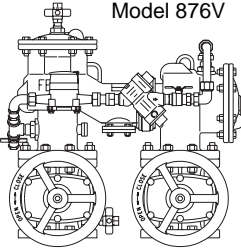
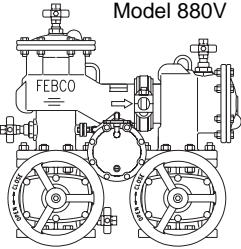
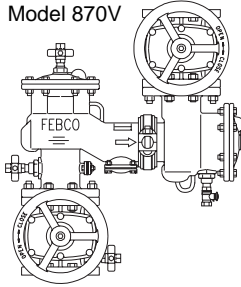
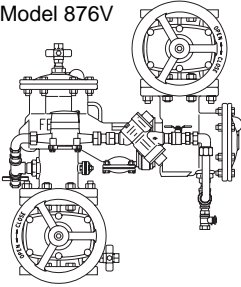
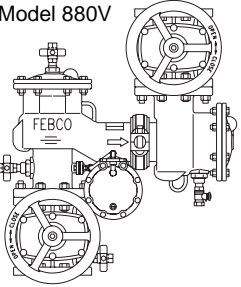
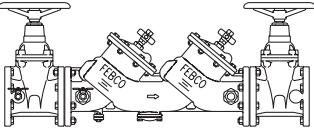
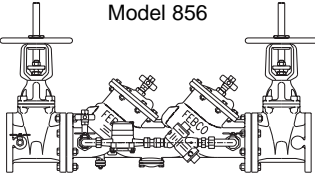
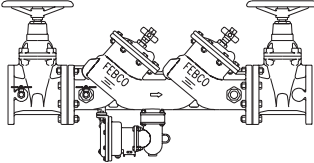
	Double Check Assembly	Double Check Detector Assembly	Reduced Pressure Assembly
"N" - Shape	 <p>Model 870V</p>	 <p>Model 876V</p>	 <p>Model 880V</p>
Vertical	 <p>Model 870V</p>	 <p>Model 876V</p>	 <p>Model 880V</p>
Conventional In-Line	 <p>Model 850</p>	 <p>Model 856</p>	 <p>Model 860</p>

For nearly half a century customers have looked to FEBCO for quality products, reliable low headloss performance, and great value. Today, with the new FEBCO MasterSeries® designs, FEBCO has once again taken the initiative with patented product innovations.

All 2½ through 10" MasterSeries products include:

- Patented VectorCheck performance for low head loss
- Cast ductile iron bodies for lighter weight
- Lowest installed cost — Saves on labor and material
- Choice of cost-saving "N"-Shape designs, revolutionary vertical designs, or conventional in-line designs.

Contact a FEBCO representative today for product literature and technical specifications on FEBCO MasterSeries® backflow prevention products.

## NOTES

## WARRANTY

All products manufactured and sold by CMB Industries, Inc. carry with them the following warranty: CMB Industries, Inc. warrants to the original purchaser (who is the end user) all products manufactured by it will be free from defects in workmanship and material for a period of one (1) year from the date of original shipment.

CMB Industries, Inc. also warrants that all internal components of 1/2" through 2" Model 850/860 and 1/2" through 1" Model 766 products, will be free from defects in workmanship and material for a period of five (5) years from the date of original shipment and also that the body only of the 1/2" through 1 1/4" Model 765 will be subject to a lifetime warranty against damage by freezing.

This warranty is applicable provided such products are used under normal conditions within the recognized pressure, flow and temperature limits and are given normal service and care. CMB INDUSTRIES, INC. MAKES NO OTHER REPRESENTATION OR WARRANTY OF ANY KIND, EXPRESSED OR IMPLIED, IN FACT OR IN LAW, AND EXPRESSLY DISCLAIMS ALL OTHER WARRANTIES, INCLUDING WITHOUT LIMITATION, THE WARRANTIES OF MERCHANTABILITY OR FITNESS FOR PARTICULAR PURPOSE. In the event of a defect in material or workmanship of a product covered by this warranty, CMB Industries, Inc. shall, at its sole option, repair or replace such defective product. CMB Industries, Inc. shall not be liable for any labor required to repair or replace any product covered by this warranty. This warranty is void with respect to any such product which is altered or tampered with by anyone without prior consent of CMB Industries, Inc. CMB Industries, Inc. shall not be liable under any circumstances for damages caused by accident, misuse or abuse of the product or for failure to follow the installation, maintenance or operating instructions. IN NO EVENT SHALL CMB INDUSTRIES BE LIABLE FOR CONSEQUENTIAL, INCIDENTAL, INDIRECT, PERSONAL INJURY, PROPERTY OR PUNITIVE DAMAGES.

To make a claim under this warranty, the buyer must notify the factory in writing within ten (10) days of discovery of any claimed defects or workmanship, and if authorized by the factory, shall return the product in the same condition as when received by the buyer, transportation prepaid, to the factory or to such other location as directed by the factory. If said returned product is found by the factory to be defective in workmanship or materials, it shall be repaired or replaced without charge, pursuant to the terms of this warranty. This warranty excludes component parts or appurtenances not manufactured by CMB Industries, Inc. Any claims with respect to such equipment must be made to the manufacturer thereof in accordance with the terms of the warranty, if any, given by such manufacturer, or pursuant to such warranties as may exist by law. The physical or chemical properties of CMB Industries, Inc. products represent typical, average values obtained in accordance with test methods and are subject to normal manufacturing variations. This information is supplied as a technical service and is subject to change without notice.

## FEBCO BACKFLOW PREVENTION...

**A product of CMB Industries, Inc.**

CMB Industries Inc. is a leader in the water control market with more than 75 years of experience in the design and manufacturing of the world's most innovative water control products. CMB products include FEBCO Backflow Preventers, K-FLO Butterfly Valves and POLYJET Control Valves. As an ISO 9001 Certified manufacturer, CMB is committed to quality and performance.

For more information about FEBCO Backflow Preventers, visit our web site at [www.FEBCOonline.com](http://www.FEBCOonline.com) or request our interactive CD, CMB+, with its electronic catalog, valve selection guide, and technical drawings and data.



Post Office Box 8070 • Fresno, California • U.S.A.  
Tel# (559) 252-0791 • Fax# (559) 453-9030 • [www.cmb-ind.com](http://www.cmb-ind.com) • [www.FEBCOonline.com](http://www.FEBCOonline.com)