

Standard Materials

Body & Cover: Ductile Iron ASTM A536
 Coating: NSF Listed Fusion Bonded Epoxy Lined and Coated
 Trim: 316 Stainless Steel
 Elastomers: Buna-N (standard)
 EPDM
 Viton
 Stem, Nut & Spring: Stainless Steel

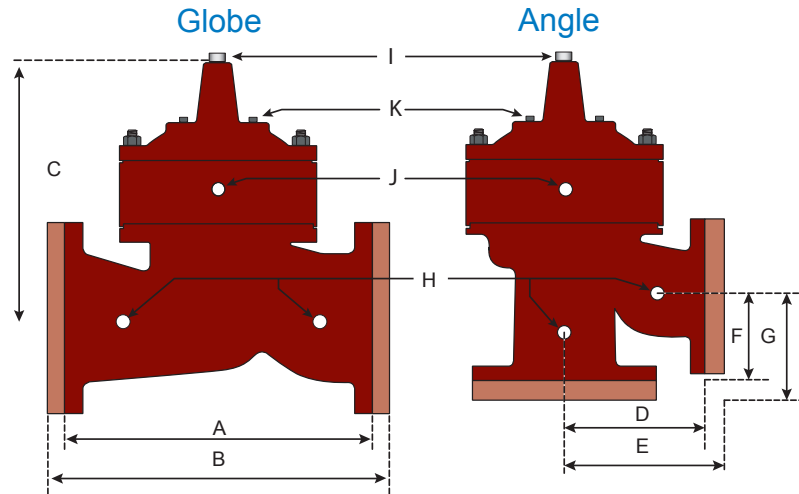

Dimensions

	A	B	C	D	E	F	G	H	I	J	
VALVE SIZE	GLOBE 150#	GLOBE 300#	COVER TO CENTER	ANGLE 150#	ANGLE 300#	ANGLE 150#	ANGLE 300#	PORT SIZE	PORT SIZE	PORT SIZE	SHIPPING
3	10-1/4	11	9-1/16					3/8	1/2	1/4	31
4	13-7/8	14-1/2	11-11/16	6-15/16	7-1/4	5-1/2	5-13/16	1/2	1/2	1/2	50
6	17-3/4	18-5/8	15-1/4	8-7/8	9-3/8	6-3/4	7-1/4	3/4	3/4	1/2	130
8	21-3/8	22-3/8	20-1/8	10-11/16	11-3/16	7-1/4	7-3/4	3/4	3/4	3/4	210
10	26	27-3/8	23-11/16					1	1	1	363
12	30	31-1/2	26-1/4					1	1	1	528
16	35	36-5/8	34-1/8					1	1-1/4	1	826
18	48	49-5/8	41					1	2	1	1365
20	48	49-5/8	41					1	2	1	1390
24	48	49-3/4	41					1	2	1	1485

*Estimated in lbs.

Description

The Watts ACV Models 600GD-16 and 600AD-16 are reduced port, dual chamber basic valves that incorporate a two-piece telescoping disc and diaphragm assembly. This assembly is the only moving part within the valve, allowing it to open or close as commanded by the pilot control system. The lower portion of this two-piece assembly is a mechanical check feature, which acts independent of diaphragm position or pilot control system, and provides immediate check action when flow ceases.

When pressure is applied to the upper diaphragm chamber and released from the lower diaphragm chamber, the valve travels to a closed position. When pressure is applied to the lower diaphragm chamber and released from the upper diaphragm chamber the valve travels to a full open position.

Model 600GD-16: Globe Pattern Dual Chamber Basic Valve with Mechanical Check Feature

Model 600AD-16: Angle Pattern Dual Chamber Basic Valve with Mechanical Check Feature

Operating Pressure

Threaded = 400 psi / 150 Flanged = 250 psi / 300 Flanged = 400 psi

Operating Temperature

Buna-N: 160°F Maximum

EPDM: 300°F Maximum

Viton: 250°F Maximum

Flow Data - ACV 600GD-16 (Globe) / 600AD-16 (Angle)

Valve Size - Inches	3	4	6	8	10	12	16	18	20	24
Maximum Continuous Flow Rate Gpm (Water)	210	485	800	1850	3100	5000	7000	11100	11100	11100
Maximum Intermittent Flow Rate Gpm (Water)	265	590	1000	2300	4000	6250	8900	14100	14100	14100
CV Factor GPM (Globe)	60	133	224	489	932	1428	2067	2881	2881	2881
CV Factor GPM (Angle)		132	237	534						

Estimated

Maximum continuous flow based on velocity of 20 ft. per second.

Maximum intermittent flow based on velocity of 25 ft. per second.

The C_v Factor of a valve is the flow rate in US GPM at 60° F that will cause a 1 psi drop in pressure.

The factors stated are based upon a fully open valve.

Cv factor can be used in the following equations to determine Flow (Q) and Pressure Drop (Δ P):

$$Q (\text{Flow}) = C_v \sqrt{\Delta P} \quad \Delta P (\text{Pressure Drop}) = (Q/C_v)^2$$

Headloss

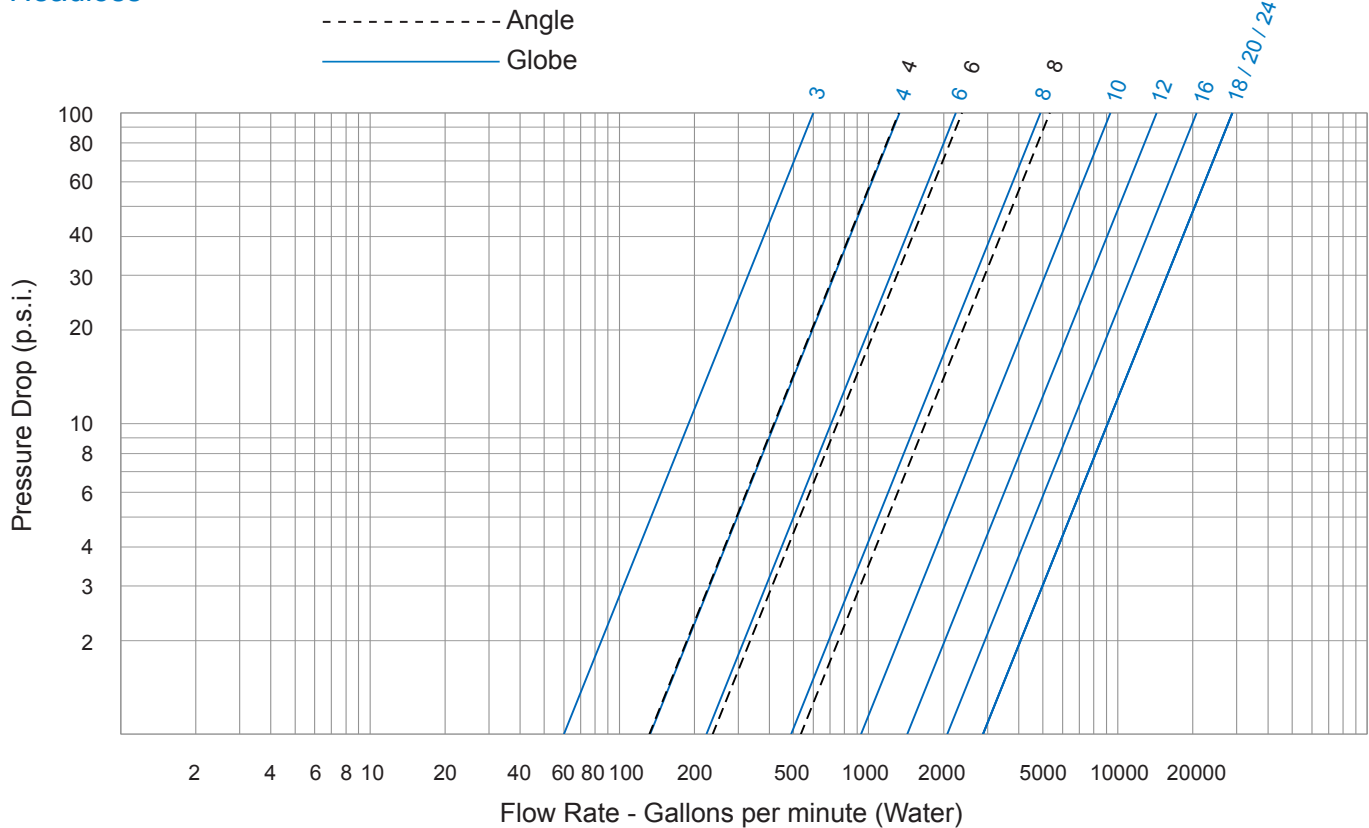

Valve Cover Chamber Capacity

Valve Size (in)	3	4	6	8	10	12	16	18	20	24
fl.oz.	4	10	22	70						
U.S. Gal					1-1/4	2-1/2	4	9-1/2	9-1/2	9-1/2

Valve Travel

Valve Size (in)	3	4	6	8	10	12	16	18	20	24
(in)	1/2	3/4	1	1-1/2	2	2-1/2	3	4	4	4