

# POWERS™

## REPAIR FORM

### HydroGuard® 400/410/2000 Pressure Balancing Valves All Models

#### DESCRIPTION

The Hydroguard 400/410 pressure balancing valve insures safety to the bather upon hot or cold water supply pressure failure or change. The internal balance chamber forces the hot or cold water supply pressure to be equalized should either pressure fail or change. To ensure correct repair parts are installed, determine valve model by referring to bonnet label (see *Figure 1*). Once model number is determined, refer to appropriate chart to ensure correct kit has been supplied. **Since kits contain parts for multiple models, discard extra parts.**

#### REPAIR INSTRUCTIONS

##### Replace Balance chamber if...

- The discharge water temperature is variable or untempered.
- The valve leaks after it is completely shut off.

##### Balance Chamber Removal:

**TO REMOVE THE BALANCE CHAMBER**, using a balance chamber extraction tool (Part No. 401-202) is highly recommended. To use the extraction tool, follow instructions below:

- Insert hooked ends of extraction tool into HOT and COLD outlet ports of the balance chamber (see *Figure 2*).
- Insert screwdriver down through end of extraction tool.
- Place a wood or plastic block (do not use metal) between screwdriver and valve body. Firmly ease screwdriver away and downward, using wood for added leverage as cartridge is gradually pulled out.

**Figure 2: Balance Chamber Removal**

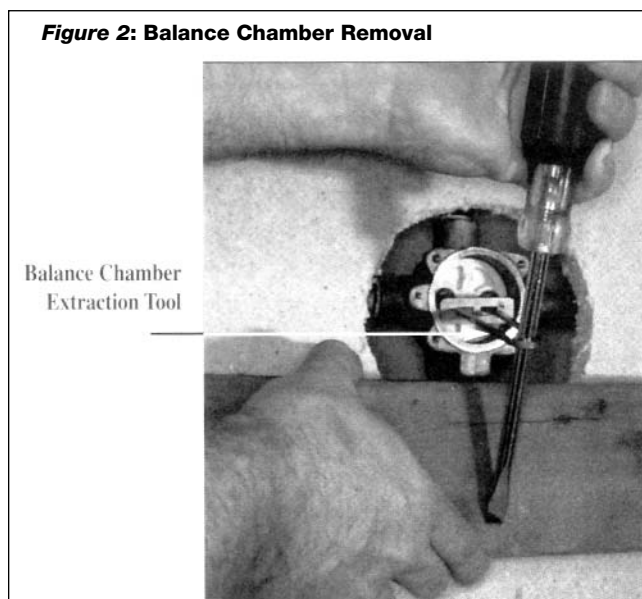

**FIGURE 1: Determine Your Valve Model**

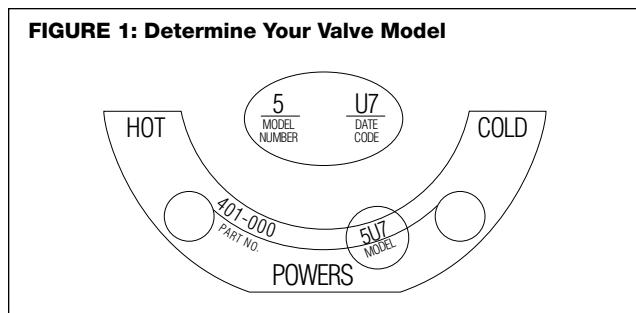

##### Balance Chamber Installation:

- Apply a small amount of silicone supplied to inner surface of valve body and inlet "O"-rings of balance chamber.
- Align chamber and valve body inlet holes.
- Slowly push chamber in, being very careful not to pinch side "O"-rings (item 5A in *figures 5 and 6*).

##### Replace Gasket and Disks if...

- Flow continues after mixer is turned off.
- Stem or handle is damaged.
- Water leaks at stem and/or bonnet.

##### Gasket and Disc Replacement:

- Replace all gaskets and discs according to the diagrams as shown in *figures 5 and 6*. Use silicone gel provided on all "O"-rings and related surfaces. Never use grease.
- The number of flat washers required for installation on stem varies with each model. Refer to *Figure 3* when replacing the washers.

**Figure 3: Number of Flat Washers to Use By Model**

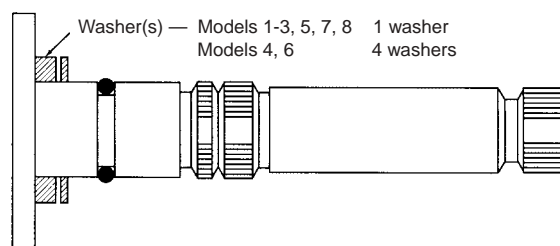

**NOTE: Be certain to refer to Figure 5 or Figure 6 to locate the appropriate parts and kits for your model.**

**REPAIR INSTRUCTIONS (CONTINUED)**

**Replace Stem and Plate if...**

- Flow continues after mixer is turned off.
- Water leaks at stem and/or bonnet.

**NOTE:** For reversed inlets, be sure to clearly identify the Hot and Cold inlet ports to avoid confusion during future maintenance.

**Stem and Plate Replacement**

1. FOR STANDARD INLETS: Place the plate directly on top of the balance chamber (see *Figure 4* for proper orientation of plate).
2. The flat notch on the splined stem must **FACE** the outlet port of the valve body for standard inlets (cold water entering COLD inlet port).
3. FOR REVERSED INLETS: (cold water entering hot inlet port), the flat notch on the splined stem must face **AWAY FROM** the outlet port. See *Figure 4A* for proper orientation of plate.

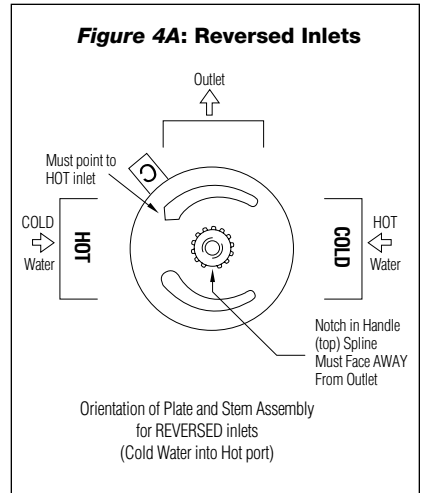
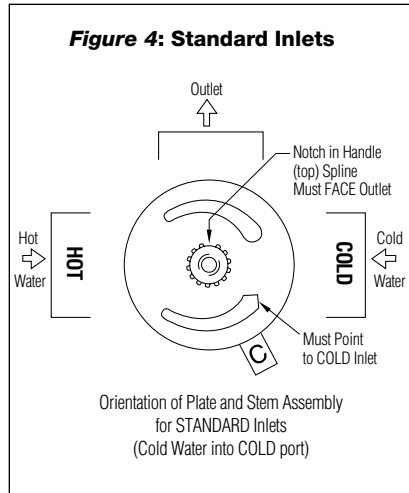

**PARTS**

**Figure 5: HydroGuard 400/410 Models 1-3, 5, 7, 8.**

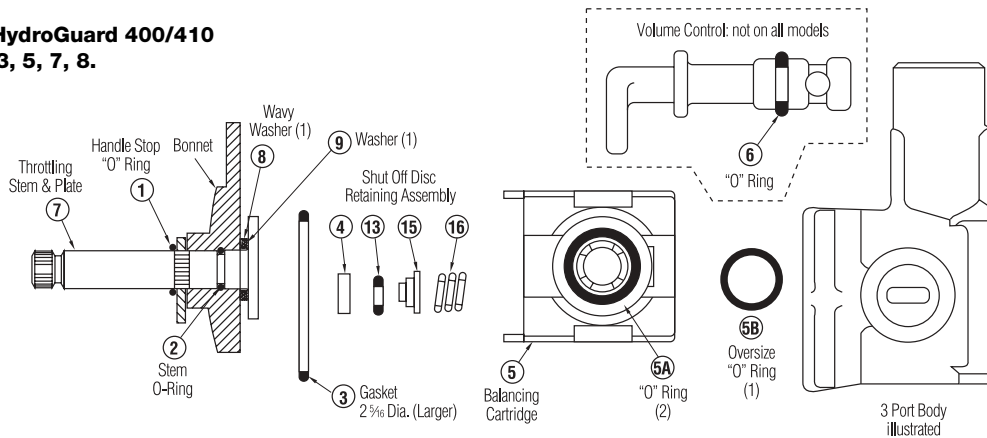

Troubleshooting		Repair Kit No.	Where Used	Repair Kit Includes (Numbers below correspond with numbers in Figure 5 above)
1. Cartridge slips while seated in body. 2. Flow continues after mixer is turned off and all other seals have been replaced.	Oversize 410 Inlet Seal Kit*	410-570*	400/410 All Models	1-4, 5A, 5B*, 6**
1. Water leak at stem and/or bonnet. 2. Flow continues after mixer is turned off.	Gasket and Disc Replacement	410-182	400/410 All Models	1-4, 5A, 6**
1. Variable or untempered discharge temperature. 2. Leakage after mixed is turned off.	Balance Chamber	410-183 (for any 3-port valve)	400: Models 1-3 410: Models 1-3, 7, 8 Metal and Plastic Bonnet	3-5, 5A, 13, 15, 16**
1. Flow continues after mixer is turned off. 2. Handle splines on stem damaged.	Stem and Plate Replacement	410-378	400: Models 1-3 410: All Models	1-4, 7-9***
		410-378A	419's only	1-4, 7-9** 1-4, 7-9*** (shorter stem)

\* When using oversize O-ring (item 5B), discard ONE of the two regular sized O-rings (5A) normally used and use item 5B in its place.

\*\* Use O-ring only on Hydroguard 412/414. Others use gasket.

\*\*\* Item 7 has brass stem and Celcon Plastic Mixing Plate (refer to Figures 4 and 4A).

PLEASE NOTE: Some kits contain parts for more than one model. Discard additional parts as appropriate.

**PARTS (CONTINUED)****Figure 6:**

**HydroGuard 400 - Models 4 & 6**  
**HydroGuard 410 - Model 4**  
**HydroGuard 2000 - Model 1**

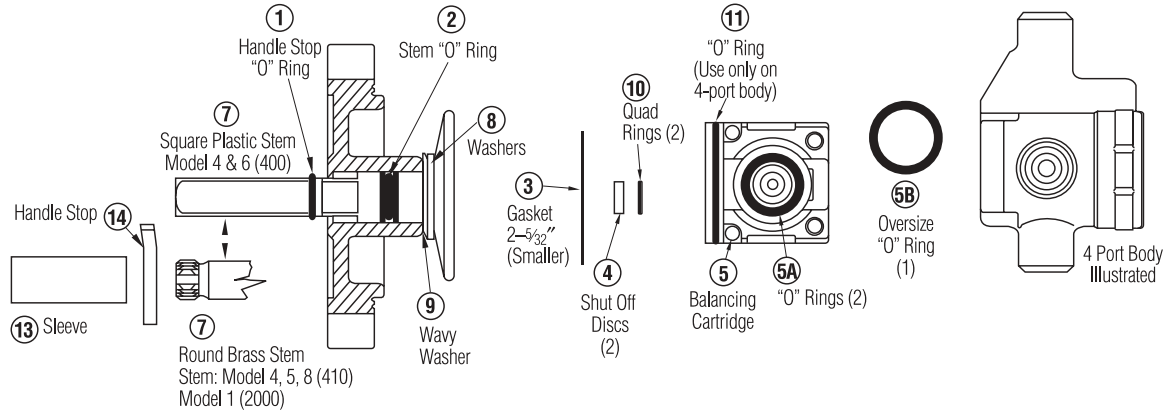

Troubleshooting		Repair Kit No.	Where Used	Repair Kit Includes (Numbers below correspond with numbers in Figure 6 above)
1. Cartridge slips while seated in body. 2. Flow continues after mixer is turned off and all other seals have been replaced.	Oversize 410 Inlet Seal Kit*	410-570*	400/410 All Models	1-4, 5A, 5B*, 10, 11 Use item 11 only in Models 4-6, 4-port body (see Note 1 below)
1. Water leak at stem and/or bonnet. 2. Flow continues after mixer is turned off.	Gasket and Disc Replacement	410-182	400/410 All Models	1-4, 5A, 10, 11 Use item 11 only in Models 4-6, 4-port body (see Note 1 below)
1. Variable or untempered discharge temperature. 2. Leakage after mixed is turned off.	Balance Chamber	401-175 (for any 4-port valve)	400: Models 1-3 410: Models 1-3, 7, 8 Metal and Plastic Bonnet	3-5, 5A, 10, 11 Use item 11 only in Models 4-6, 4-port body (see Note 1 below)
		410-183 (for any 3-port valve)	410: Any 3-port valve	3-5, 5A, 11, 13, 15, 16** (refer to Fig. 5) (see Note 1 below)
1. Flow continues after mixer is turned off. 2. Handle splines on stem damaged.	Stem and Plate Replacement	401-176	400: Models 4-6	1-4, 7-9 Item 7 has square plastic stem and plate (see Note 2 below)
		410-378	410: All Models 2000: All Models	1-4, 7-9 Item 7 has round brass stem and plastic plate (refer to Fig. 3)

For parts not covered above, refer to Technical Instruction Form MV400, MV410 or T1410-5.

\* When using oversize O-ring (item 5B), discard ONE of the two regular sized O-rings (5A) normally used and use item 5B in its place.

\*\* Use O-ring only on Hydroguard 412/414. Others use gasket.

**Note 1:** O-ring, item 11, is used only in 4-port mixers.

**Note 2:** "C" on stem must face cold water inlet. For Model 4-400, you must also order new handle for new brass stem.

Order either Lucite handle kit #410-383 or lever handle kit #410-384.

**PLEASE NOTE:** Some kits contain parts for more than one model. Discard additional parts as appropriate.

**MAXIMUM TEMPERATURE SETTING/HANDLE ROTATION STOP**

**MAXIMUM TEMPERATURE SETTING** (refer to *Figure 7*).

This must be set on the job and following any maintenance or servicing to the valve. Mixer is factory set to pass full HOT water.

- a. Loosen adjustment stop screw (do not remove). Gradually rotate stem counterclockwise to get desired maximum water temperature. (Maximum Temperature Stop will rotate long with the stem when the stem is rotated).
- b. Once stem has been rotated to desired temperature, slide adjustment stop clockwise until fin on adjustment stop touches the maximum temperature stop.
- c. While holding adjustment stop in place, tighten adjustment stop screw.
- d. Replace handle. Confirm maximum temperature has been set properly by operating the valve using the handle.

**Caution: Adjustment stop must be present for proper operation.**

**Figure 7: Maximum Temperature Setting**

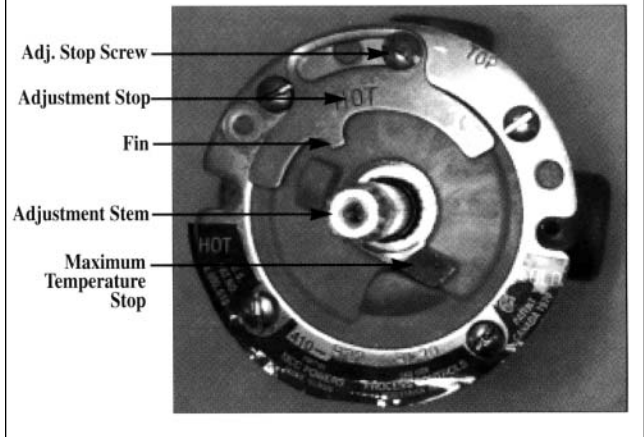

**CALIFORNIA PROPOSITION 65 WARNING**

**WARNING:** This product contains chemicals known to the State of California to cause cancer and birth defects or other reproductive harm. (California law requires this warning to be given to customers in the State of California.)

For more information: [www.watts.com/prop65](http://www.watts.com/prop65)