

Colt Series

200 Double Check Assembly

300 Double Check Detector Assembly

400 Reduced Pressure Zone Assembly

500 Reduced Pressure Detector Assembly

Features

- Integrated supervisory tamper switch on Series C200 and C300
- Integrated sensor for flood detection on Series C400-FS, C500-FS, and LFC500-FS; flood alert features activated with add-on connection kit, available for BMS and cellular communication
- Most compact design in the industry; smallest enclosure
- Valve body and closure sleeve manufactured from 300 Series stainless steel
- Approved with gate valves or UL Classified and FM Approved butterfly valves
- Approved for horizontal, vertical, or "N" installation
- Groove connections for ease of installation and pipe alignment
- Patented Link check modules for easy servicing and maintenance
- Minimizes flow switch fluctuation

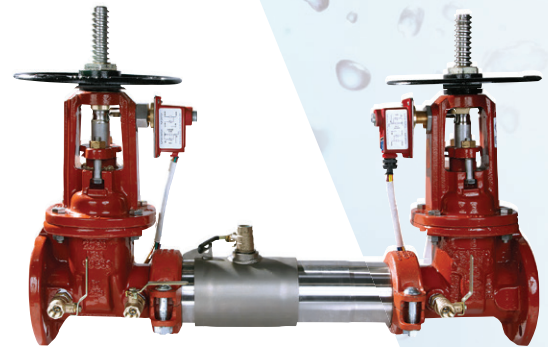

C200-OSY-TS

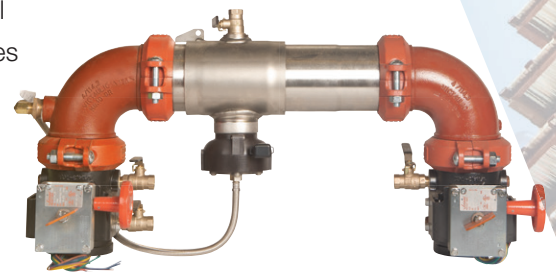

C400N-BFG-FS

Cutaway View - Full flow operation

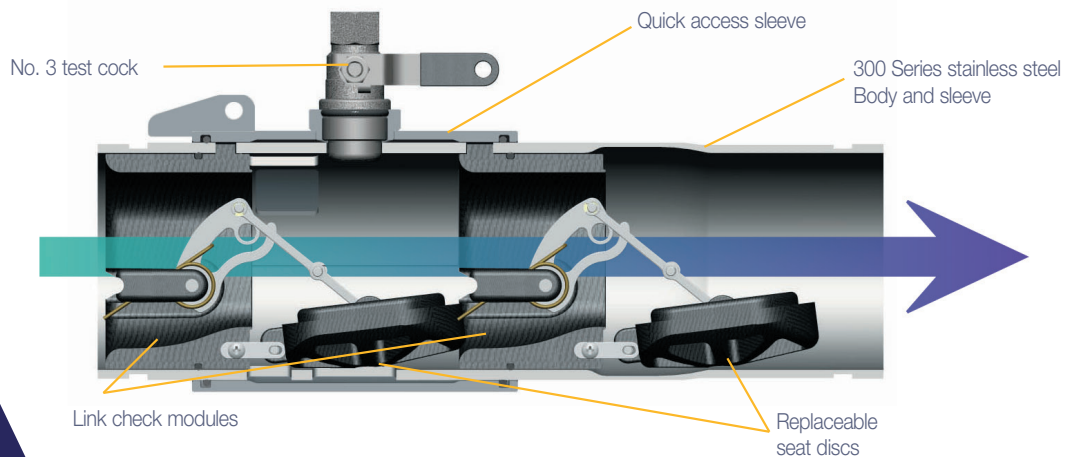

Patent Nos. 6,220,282,
6,443,181, and 6,478,047

Maxim Series

200 Double Check Assembly

300 Double Check Detector Assembly

400 Reduced Pressure Zone Assembly

500 Reduced Pressure Detector Assembly

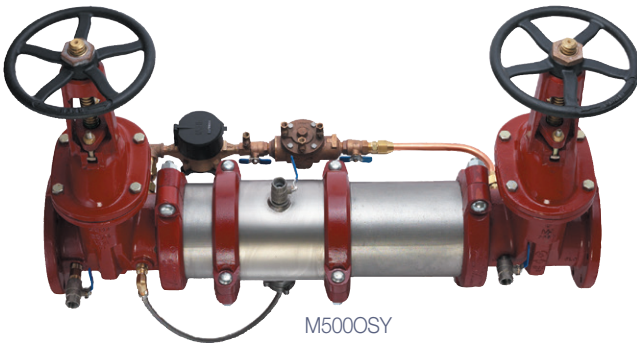

Features

- Specifically designed for high-flow fire systems
- Valve body and closure sleeve manufactured from 300 Series stainless steel
- Approved with gate valves or UL Classified and FM Approved butterfly valves
- Approved for horizontal, vertical, or "N" pattern installation
- Groove connections for ease of installation and pipe alignment
- Patented Link check modules for easy servicing and maintenance
- Quick access sleeve
- Eliminates flow switch fluctuation

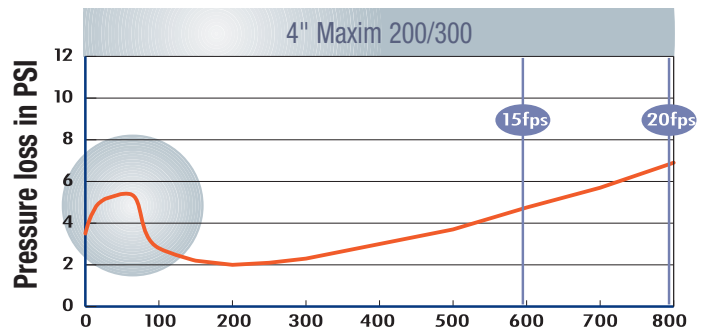

Refer to watts.com for BAA information on specific models.



A WATTS Brand