

### 1 Information Brochure

Choose controls to match application

### 2 Application Brochure

Design your mechanical applications

### 3 Rough In Wiring

Rough-in wiring instructions

### 4 Wiring Brochure

Wiring and installation of specific control

### 5 Data Brochure

Control settings and sequence of operation

### 6 Job Record

Record settings & wiring details for future reference

## Featured Products:

- tekmarNet®4 Setpoint Control 161
- tekmarNet®4 Setpoint Control 162
- Zone Expansion Module 325
- Zone Expansion Module 326
- Zone Manager 335
- Zone Manager 336
- Zone Manager 337
- Boiler Reset Module 420
- Mixing Reset Module 421
- Universal Reset Module 422
- Universal Reset Module 423
- Mixing Expansion Module 440
- Mixing Expansion Module 441
- Mixing Expansion Module 444
- tekmarNet®4 Thermostat 541
- tekmarNet®4 Thermostat 542
- tekmarNet®4 Thermostat 543
- tekmarNet®4 Thermostat 544
- tekmarNet®4 Thermostat 545
- tekmarNet®4 Thermostat 546

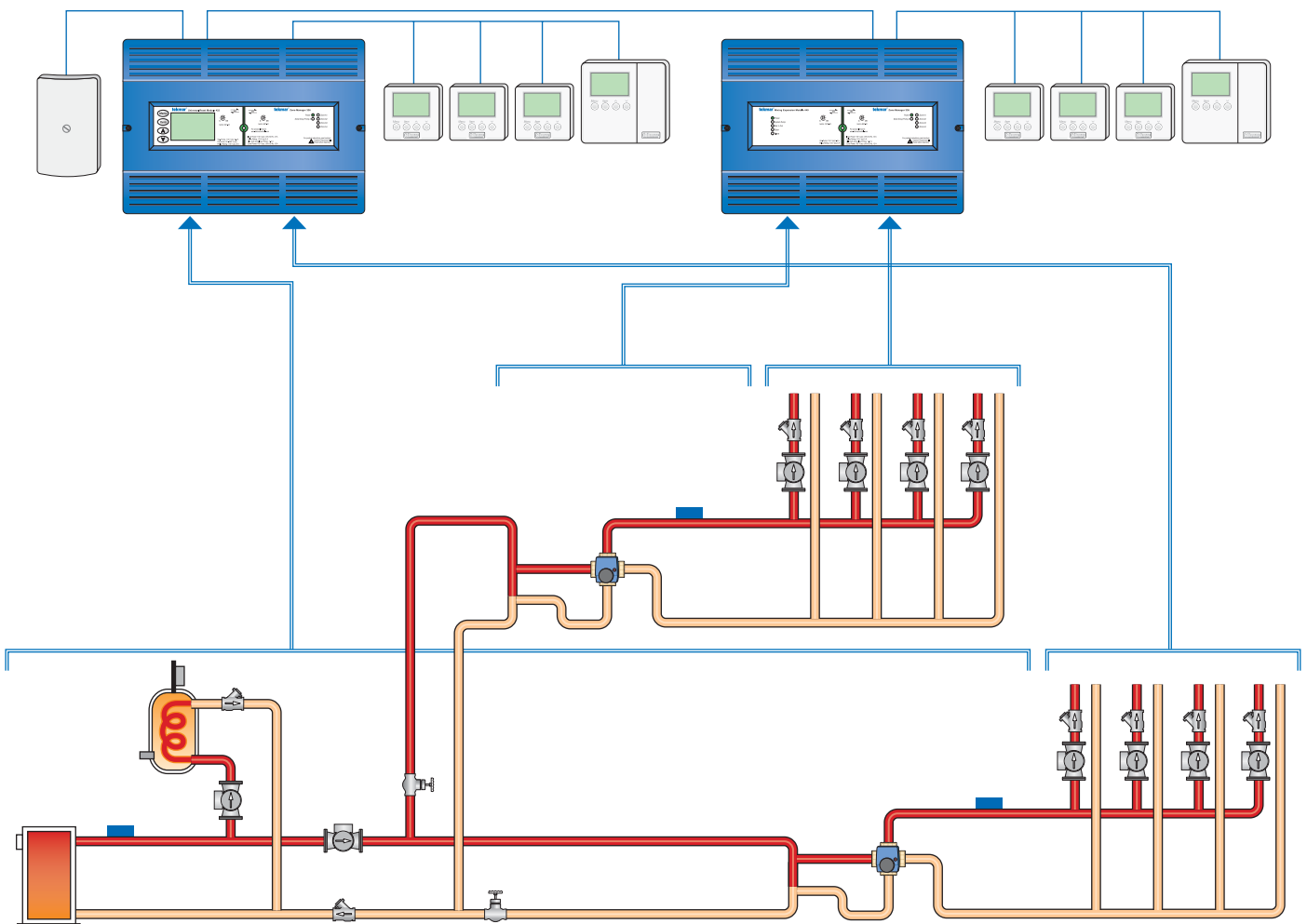

## Table of Contents

Application Information .....	4
Setpoint Applications.....	5 - 7
Reset Module Applications.....	8 - 43
Thermostat Applications.....	44 - 51

## Setpoint Applications

Application Number	Description	Page #
A162-1	Operates a pump to heat a Hot Tub and recirculation pump	5
A162-2	Operates a pump to heat a DHW tank and recirculation pump	6
A162-3	Operates a zone valve to heat a radiantfloor and a towel warmer	7

## Reset Module Applications

Application Number	DHW	Boiler Zones		Mix 1 Zones			Mix 2 Zones			Mix 3 Zones			Page #
		Valve	Pump	Device	Valve	Pump	Device	Valve	Pump	Device	Valve	Pump	
A420-1	Y		4	none			none			none			8
A420-2	Y		8	none			none			none			9
A420-3	N	6		none			none			none			10
A421-1	N			4-way	6		none			none			11
A421-2	N			var. spd.		11	none			none			12
A421-3	N			3-way	12	3	none			none			14
A421-4	N			var. spd.		4	none			none			16
A422-1	Y	3		4-way	3		none			none			17
A422-2	Y		4	4-way	6		none			none			18
A422-3	Y		4	var. spd.		4	none			none			20
A422-4	Y			4-way		4	4-way		4	none			21
A422-5	Y		4	3-way	12		none			none			22
A422-6	Y	6		var. spd.		4	none			none			24
A422-7	Y	9		3-way	9		none			none			26
A422-8	Y			var. spd.		7	var. spd.		8	none			28
A422-9	Y			var. spd.	4		4-way		6	none			30
A422-10	Y			var. spd.		4	none			none			31
A422-11	Y			var. spd.	8		var. spd.		12	none			32
A422-12	Y			3-way	12		3-way	12		none			34
A423-1	Y		4	var. spd.		4	4-way	6		var. spd.	6		36
A423-2	Y		96	none			none			none			38
A423-3	Y		4	var. spd.		48	var. spd.		4	none			40
A423-4	Y			4-way	6		4-way	6		4-way	6		42

## Thermostat Applications

Application Number	Description	Page #
A542-1	Operates 1 heat stage.	44
A543-1	Operates 2 heat stages.	45
A544-1	Operates 1 heat stage, 1 cooling stage and 1 fan.	46
A545-1	Operates 2 heat stages (both hydronic), 1 cooling stage and 1 fan.	43
A545-2	Operates 2 heat stages (hydronic and forced air), 1 cooling stage and 1 fan.	48
A546-1	Operates 2 heat stages (hydronic and forced air), 2 cooling stages, 1 fan and 1 ventilation fan.	49
A546-2	Operates 2 heat stages (hydronic and forced air), 2 cooling stages, 1 fan and 1 ventilation fan.	50
A546-3	Operates 2 heat stages (both hydronic), 2 cooling stages, and 1 two-speed fan.	51

## Application Information

The following applications illustrate common mechanical components used to provide HVAC system control. Refer to the table at left to find an application that closely matches the system design required. It is possible to use a smaller number of zones than shown. To add more zones, you may require additional Zone Managers. To add mix temperatures, you may require additional Expansion Modules.

Thermostats models are only specific in the section featuring Thermostat applications. They are chosen based on the cooling, ventilation and schedule requirements of the system. Refer to the I 001 Brochure for assistance with selection of control modules and thermostats.

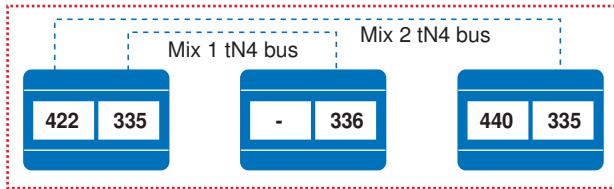

When more than one set of controls is required, wiring between control modules is shown above the control icons. Refer to the Wiring brochure of each control for specific information about which terminals to connect when adding additional control modules.

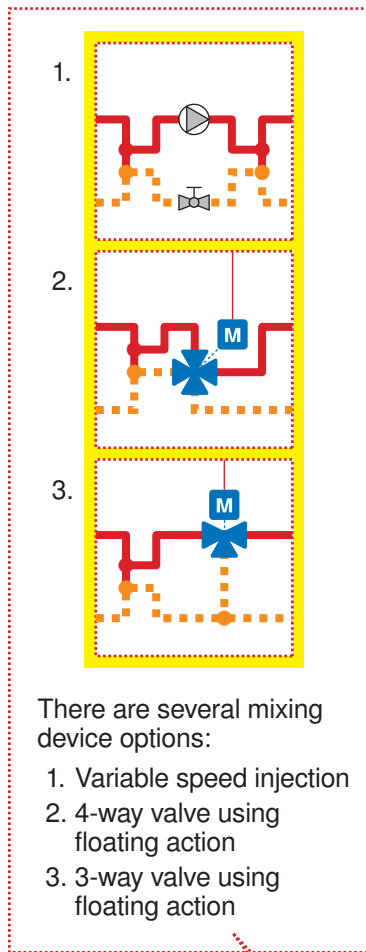

Shows the maximum number of thermostats that can connect to the Zone Manager. Also describes which tekmarNet®4 bus the thermostats are connected to.

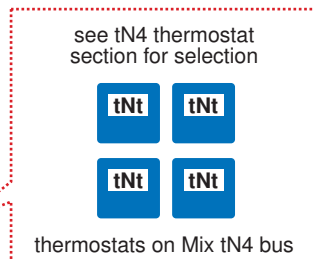

Sensors, pumps, valves and other devices are labelled for reference in a drawing legend.

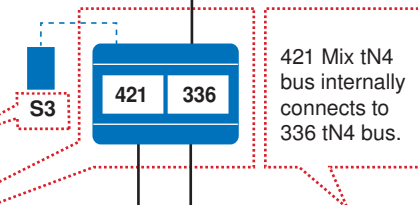

Control Combination

Describes how the internal tekmarNet®4 buses are connected.

Line identifies which control operates a mechanical equipment group.

Mechanical equipment operated by Zone Manager.

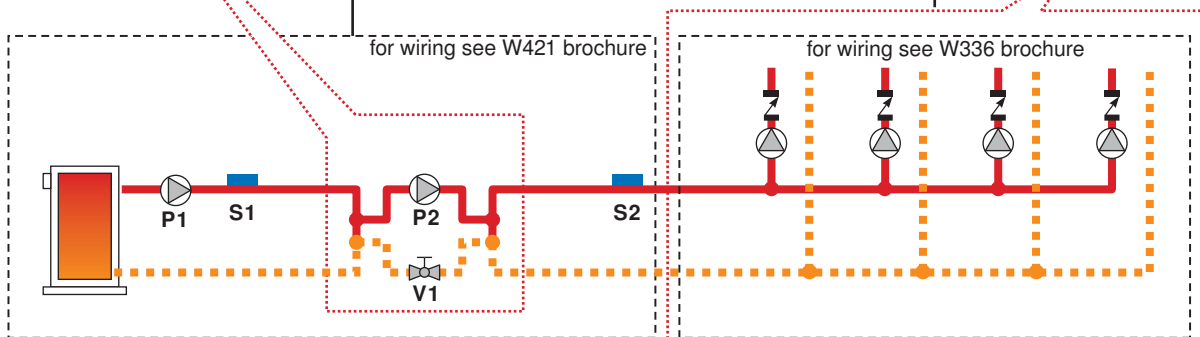

## Application A 162-1

**System Description:** Application Mode 2 is designed specifically to heat hot tubs using an on/off differential. A sensor must be located in a temperature well on the recirculation pipe. The hot tub can have an occupied, unoccupied, and away temperature setting.

**Concept Drawing:** This is only a concept drawing, not an engineered drawing. It is not intended to describe a complete system, nor any particular system. It is up to the system designer to determine the necessary components for and configuration of the particular system being designed, including additional equipment, isolation relays (for loads greater than the control's specified output ratings), and any safety devices which in the judgement of the designer are appropriate, in order to properly size, configure and design that system and to ensure compliance with building and safety code requirements.

### Legend:

P1 = Hot Tub Pump  
P2 = Hot Tub Circulation Pump  
S1 = Hot Tub Sensor 071

MODE = 2

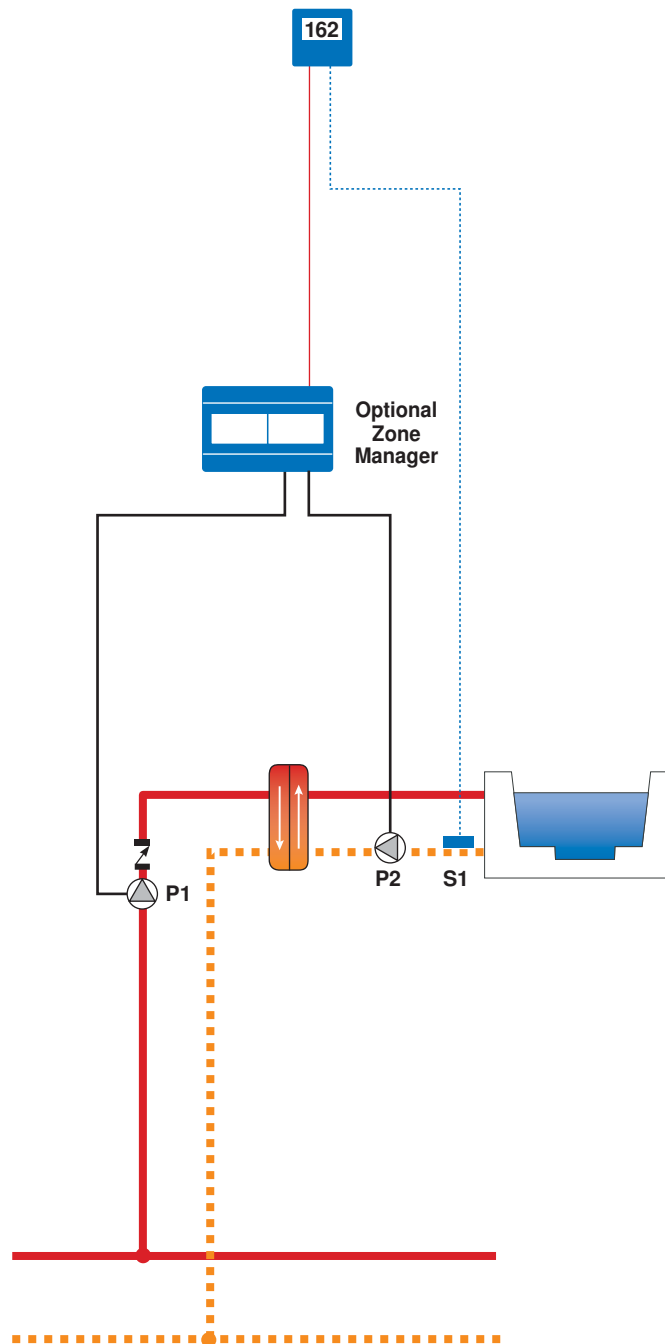

## Application A 162-2

**System Description:** Application Mode 3 is designed specifically to operate a domestic hot water (DHW) tank using an on/off differential. A sensor must be located in a temperature well inside the DHW tank. The DHW tank can have an occupied, unoccupied, and away temperature setting. The 162 includes a timer for the DHW recirculation line.

**Concept Drawing:** This is only a concept drawing, not an engineered drawing. It is not intended to describe a complete system, nor any particular system. It is up to the system designer to determine the necessary components for and configuration of the particular system being designed, including additional equipment, isolation relays (for loads greater than the control's specified output ratings), and any safety devices which in the judgement of the designer are appropriate, in order to properly size, configure and design that system and to ensure compliance with building and safety code requirements.

### Legend:

P1 = DHW Pump  
P2 = Recirculation Pump  
S1 = DHW Tank Sensor 071

**MODE = 3**

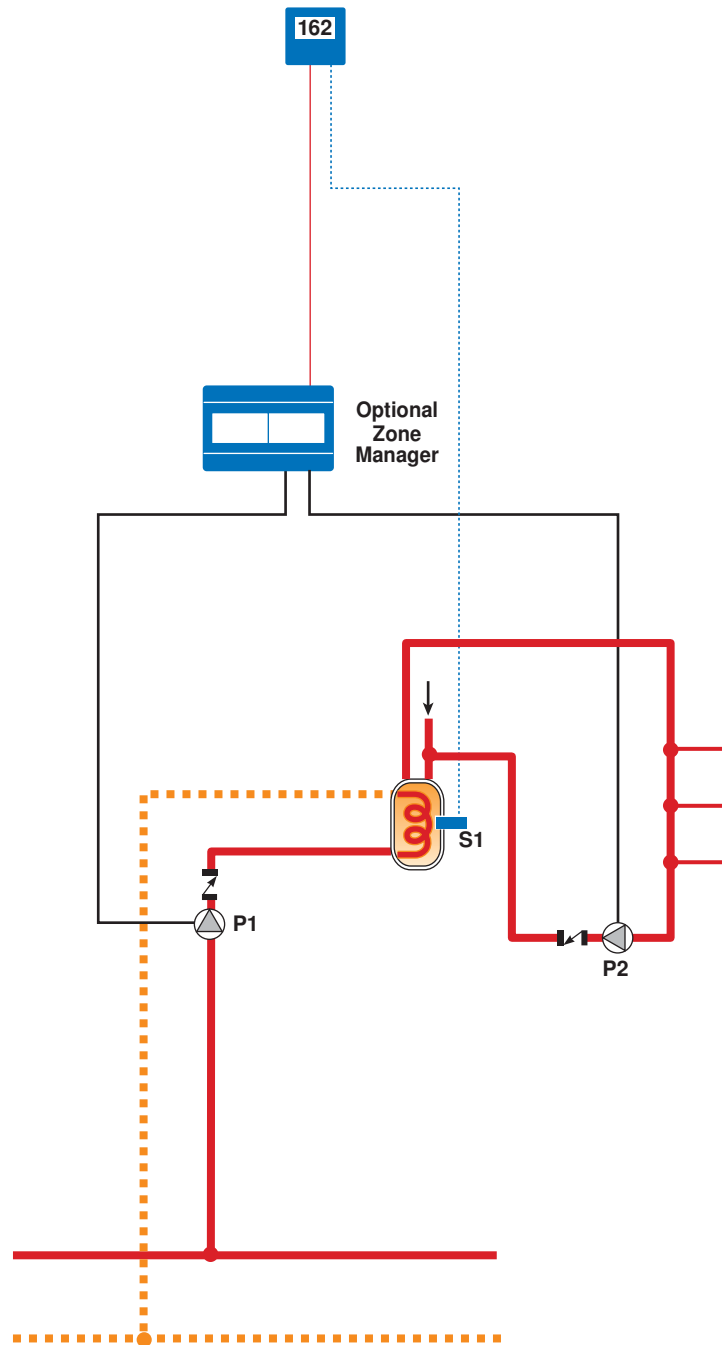

## Application A 162-3

**System Description:** Application Mode 5 configures the setpoint control for floor warming and floor heating applications using pulse width modulation. For bathroom applications, Relay 2 can also heat a towel warmer radiator while in the occupied period. A sensor must be located within the slab between the heating pipes. The setpoint control allows a Floor temperature to be set for the occupied, unoccupied, and away events.

**Concept Drawing:** This is only a concept drawing, not an engineered drawing. It is not intended to describe a complete system, nor any particular system. It is up to the system designer to determine the necessary components for and configuration of the particular system being designed, including additional equipment, isolation relays (for loads greater than the control's specified output ratings), and any safety devices which in the judgement of the designer are appropriate, in order to properly size, configure and design that system and to ensure compliance with building and safety code requirements.

### Legend:

S1 = Slab Sensor 079  
Z1 = Radiant Floor Zone Valve  
Z2 = Towel Heater Zone Valve

MODE = 5

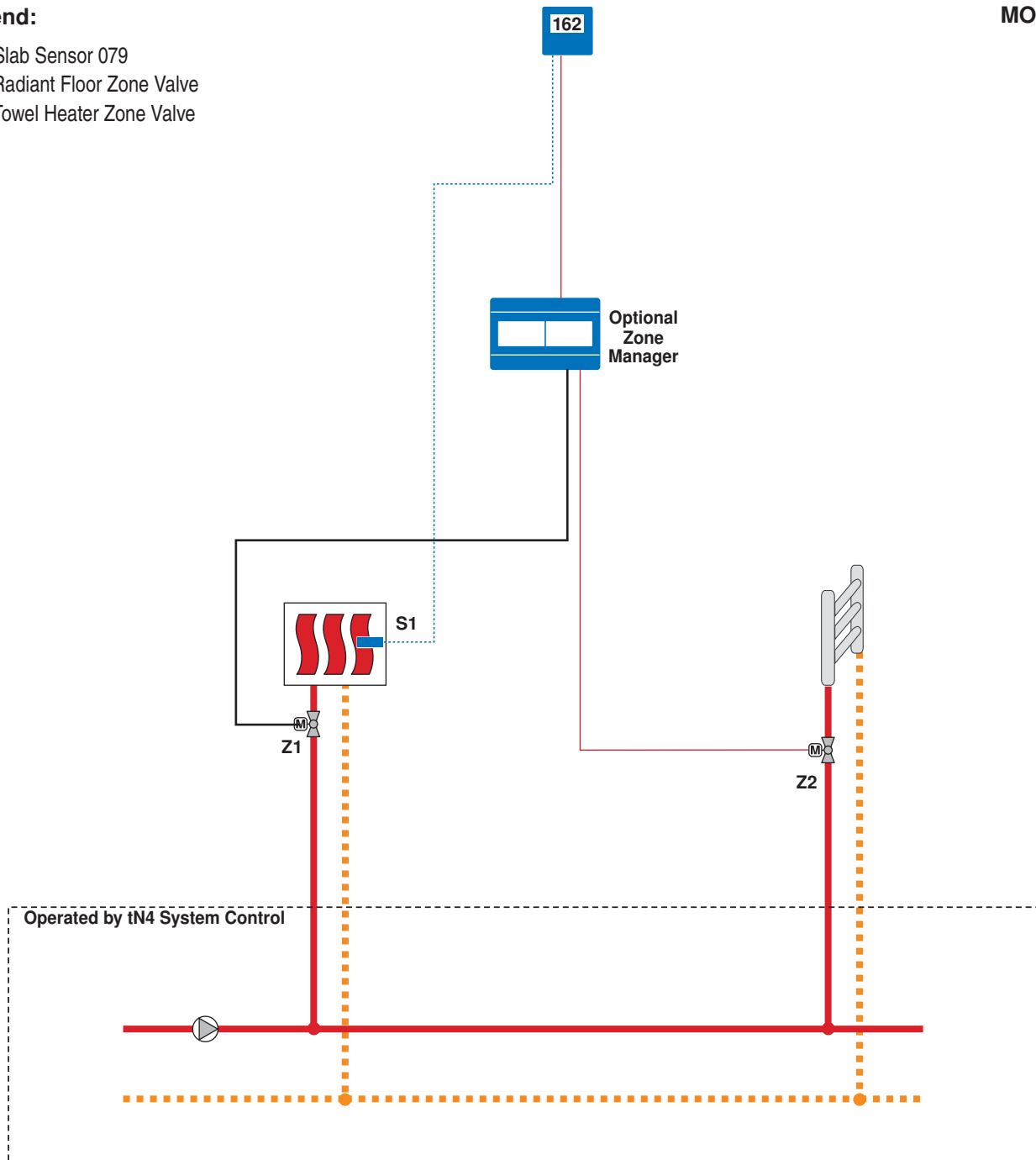

**System Description:** The Boiler Reset Module 420 operates a single on-off or modulating boiler to provide outdoor reset to the heating system and overrides the reset temperature to provide indirect domestic hot water tank heating. Priority for the indirect domestic hot water tank is optional. Four tekmarNet®4 Thermostats operate four zone pumps through the Zone Manager 336. A tekmarNet®4 boiler bus allows the thermostats to communicate to the 420 in order to provide indoor feedback to fine tune the supply water temperature.

**Concept Drawing:** This is only a concept drawing, not an engineered drawing. It is not intended to describe a complete system, nor any particular system. It is up to the system designer to determine the necessary components for and configuration of the particular system being designed, including additional equipment, isolation relays (for loads greater than the control's specified output ratings), and any safety devices which in the judgement of the designer are appropriate, in order to properly size, configure and design that system and to ensure compliance with building and safety code requirements.

**Legend:**

- A1 = DHW Aquastat
- P1 = DHW Pump
- S1 = Boiler Supply Sensor 071
- S2 = Outdoor Sensor 070

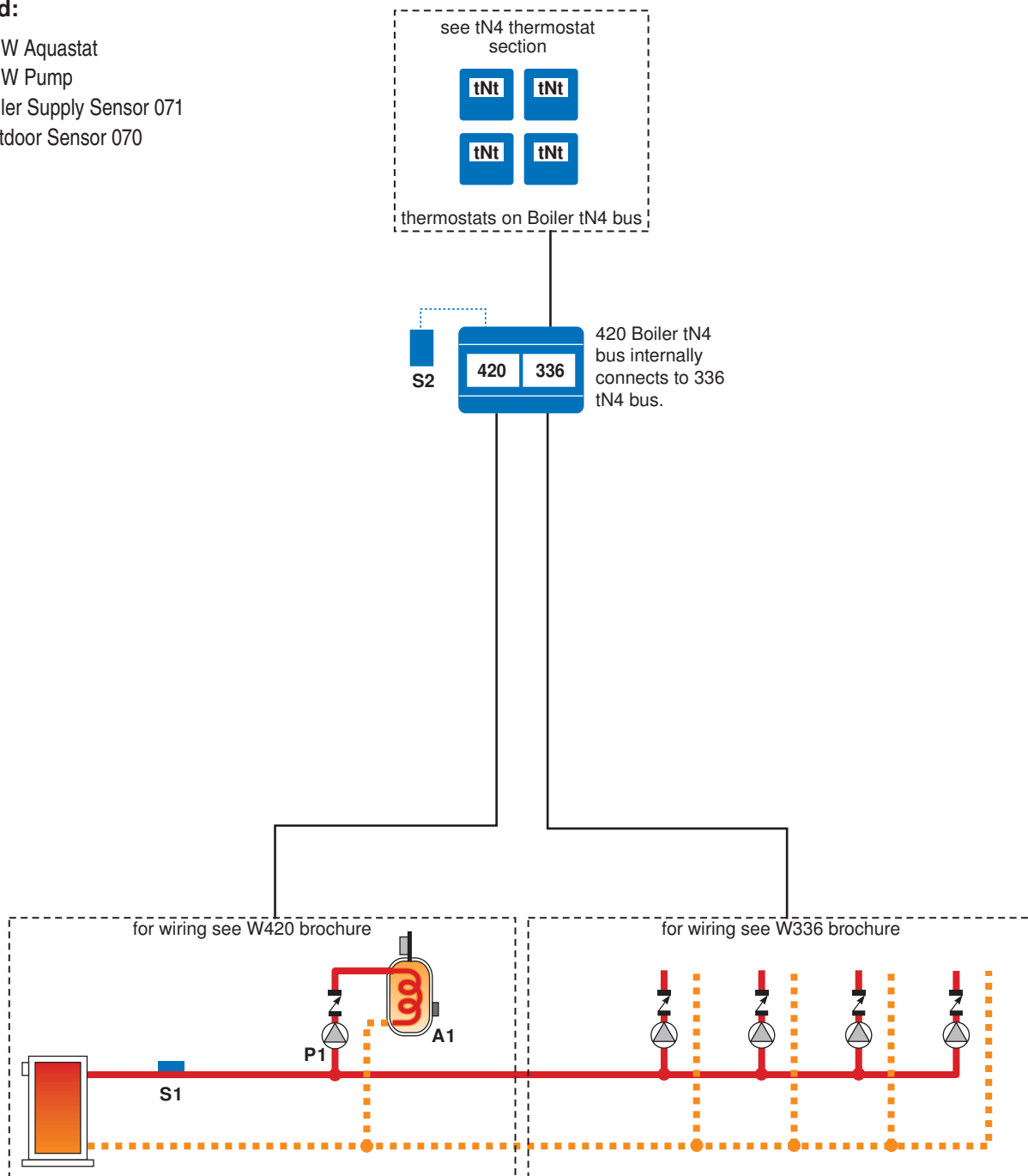

**System Description:** The Boiler Reset Module 420 operates a single on-off or modulating boiler to provide outdoor reset to the heating system and overrides the reset temperature to provide indirect domestic hot water tank heating. Priority for the indirect domestic hot water tank is optional. Eight tekmarNet®4 Thermostats operate eight zone pumps through two Zone Manager 336s. A tekmarNet®4 boiler bus interconnects the thermostats to the two 336s and the 420. This allows the thermostats to communicate with the 420 in order to provide indoor feedback to fine tune the supply water temperature.

**Concept Drawing:** This is only a concept drawing, not an engineered drawing. It is not intended to describe a complete system, nor any particular system. It is up to the system designer to determine the necessary components for and configuration of the particular system being designed, including additional equipment, isolation relays (for loads greater than the control's specified output ratings), and any safety devices which in the judgement of the designer are appropriate, in order to properly size, configure and design that system and to ensure compliance with building and safety code requirements.

**Legend:**

- A1 = DHW Aquastat
- P1 = DHW Pump
- S1 = Boiler Supply Sensor 071
- S2 = Outdoor Sensor 070

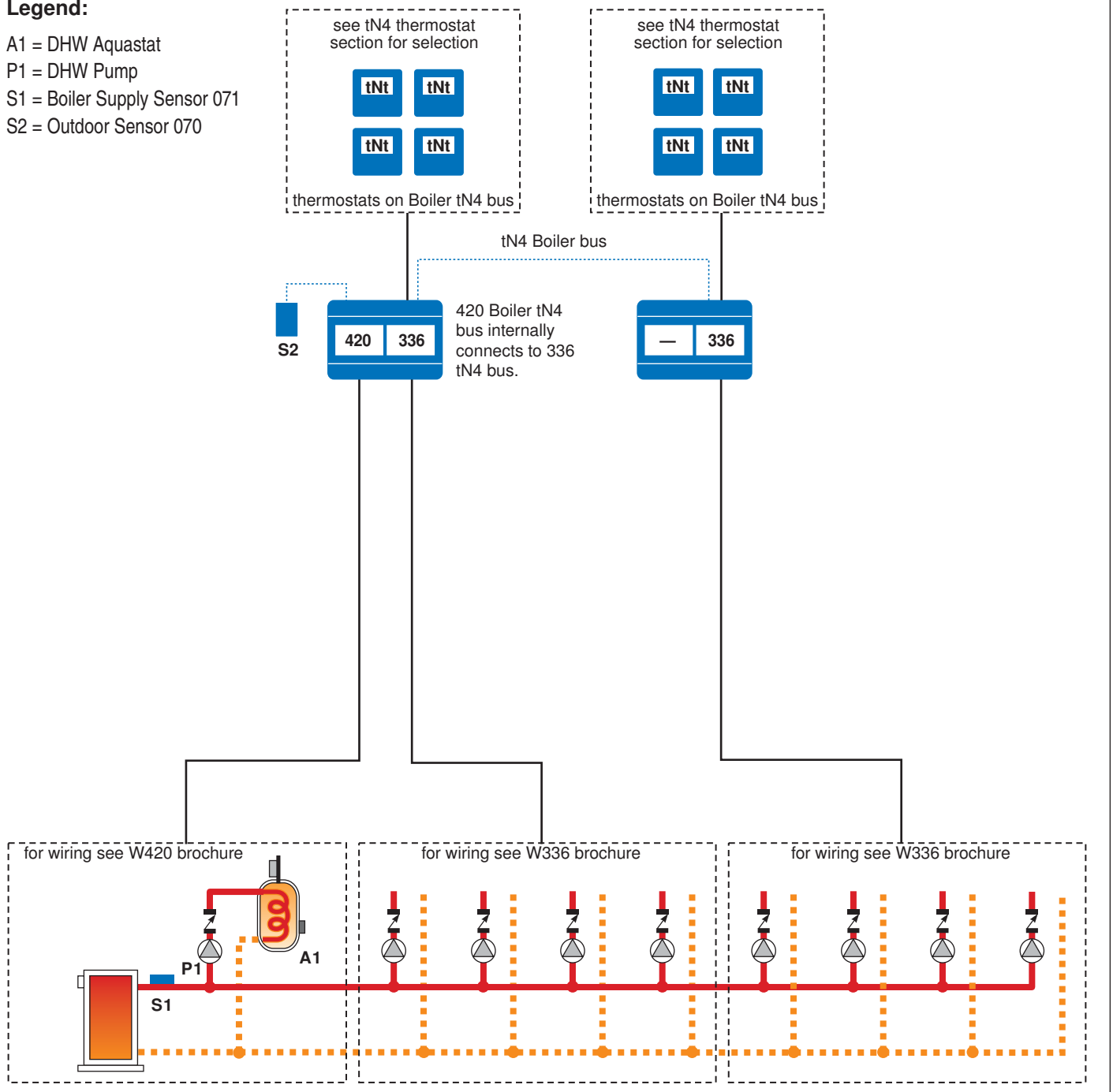

**System Description:** The Boiler Reset Module 420 operates a single on-off or modulating boiler to provide outdoor reset to the heating system. Six tekmarNet®4 Thermostats operate six zone valves through the Zone Manager 335. The 420's primary pump operates as a system pump for the six zone valves. A tekmarNet®4 boiler bus allows the thermostats to communicate to the 420 in order to provide indoor feedback to fine tune the supply water temperature.

**Concept Drawing:** This is only a concept drawing, not an engineered drawing. It is not intended to describe a complete system, nor any particular system. It is up to the system designer to determine the necessary components for and configuration of the particular system being designed, including additional equipment, isolation relays (for loads greater than the control's specified output ratings), and any safety devices which in the judgement of the designer are appropriate, in order to properly size, configure and design that system and to ensure compliance with building and safety code requirements.

**Legend:**

- P1 = Boiler Pump
- S1 = Boiler Supply Sensor 071
- S2 = Outdoor Sensor 070
- V1 = Pressure Differential Bypass Valve

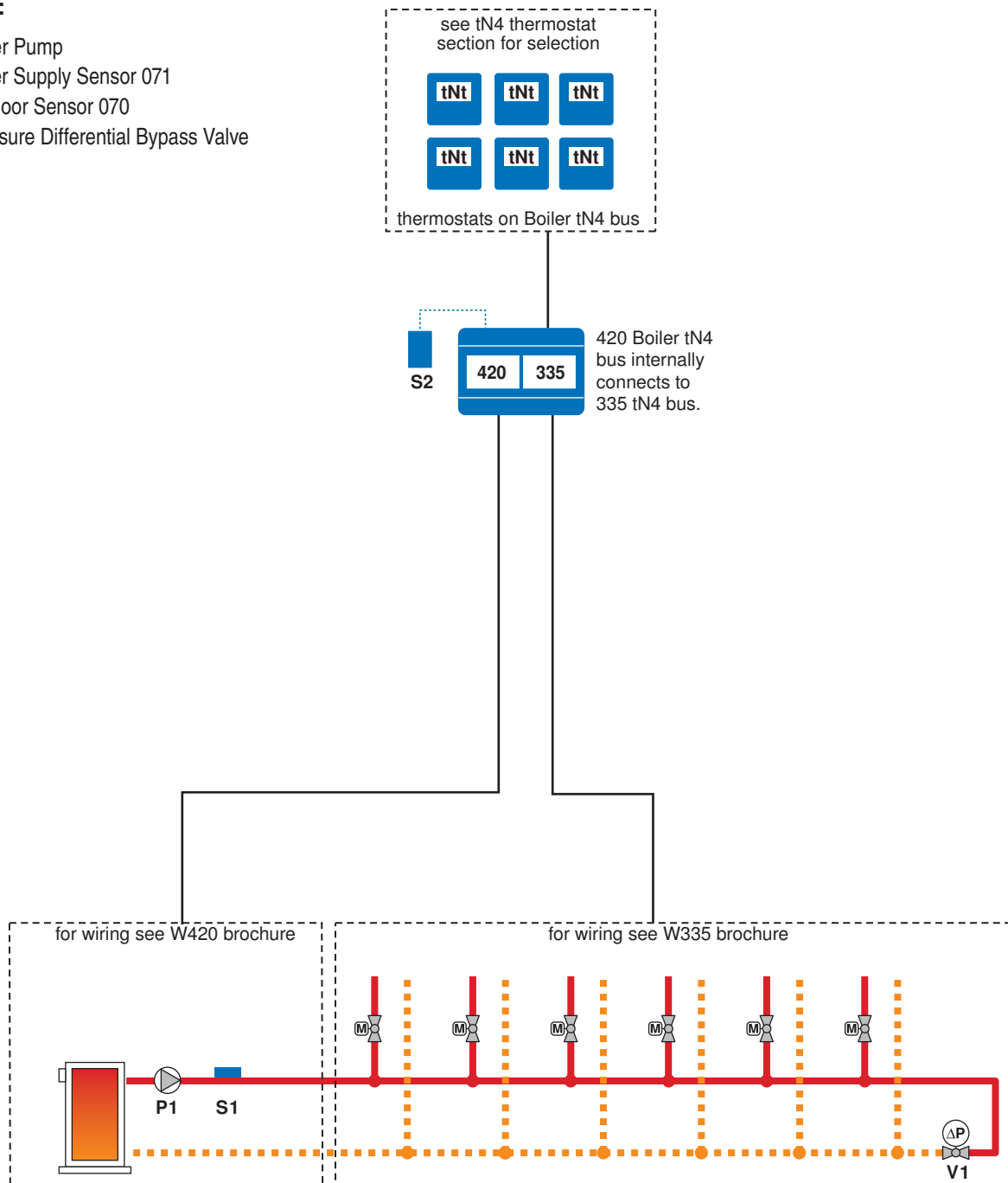

**System Description:** The Mixing Reset Module 421 operates a single on-off boiler and a 4-way mixing valve to provide outdoor reset to the heating system. The 4-way mixing valve allows the 421 to provide boiler protection from flue gas condensation. The 421's system pump output operates the boiler pump. Six tekmarNet<sup>®</sup>4 Thermostats operate six zone valves through the Zone Manager 335. A tekmarNet<sup>®</sup>4 mix bus allows the thermostats to communicate to the 421 in order to provide indoor feedback to fine tune the supply water temperature.

**Concept Drawing:** This is only a concept drawing, not an engineered drawing. It is not intended to describe a complete system, nor any particular system. It is up to the system designer to determine the necessary components for and configuration of the particular system being designed, including additional equipment, isolation relays (for loads greater than the control's specified output ratings), and any safety devices which in the judgement of the designer are appropriate, in order to properly size, configure and design that system and to ensure compliance with building and safety code requirements.

**Legend:**

- M1 = Actuating Motor 741
- P1 = Boiler Pump
- P2 = Mix System Pump
- S1 = Boiler Supply Sensor 071
- S2 = Mix Supply Sensor 071
- S3 = Outdoor Sensor 070
- V1 = Mixing Valve 720 to 724
- V2 = Pressure Differential Bypass Valve

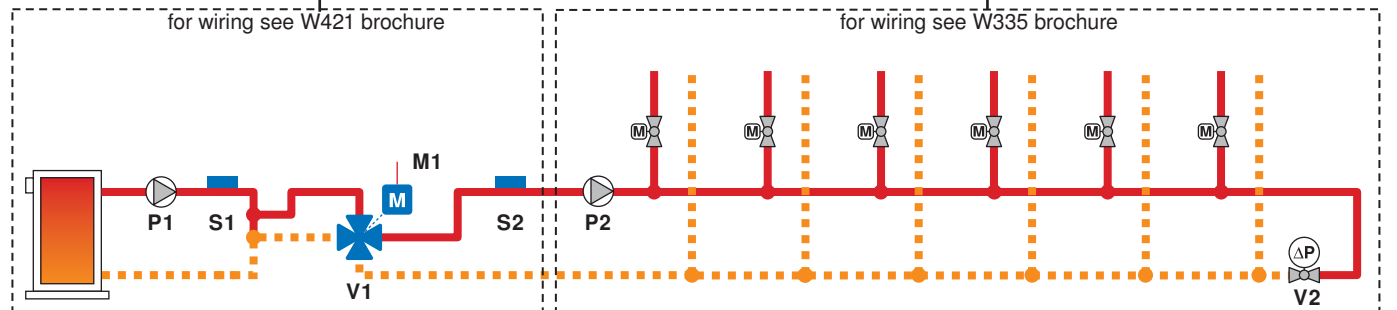
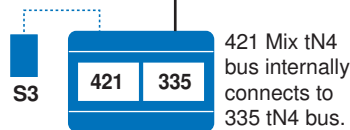
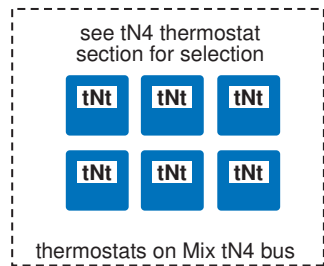

**System Description:** The Mixing Reset Module 421 operates a single on-off boiler and a variable speed injection pump to provide outdoor reset to the heating system. The variable speed injection pump allows the 421 to provide boiler protection from flue gas condensation. The 421's system pump output operates the boiler pump. Eleven tekmarNet®4 Thermostats operate eleven zone pumps through two Zone Manager 336s and one Zone Expansion Module 326. A tekmarNet®4 mix bus interconnects the thermostats to the two 336s, the 326 and the 421. This allows the thermostats to communicate with the 421 in order to provide indoor feedback to fine tune the supply water temperature.

**Concept Drawing:** This is only a concept drawing, not an engineered drawing. It is not intended to describe a complete system, nor any particular system. It is up to the system designer to determine the necessary components for and configuration of the particular system being designed, including additional equipment, isolation relays (for loads greater than the control's specified output ratings), and any safety devices which in the judgement of the designer are appropriate, in order to properly size, configure and design that system and to ensure compliance with building and safety code requirements.

**Legend:**

- P1 = Boiler Pump
- P2 = Variable Speed Injection Pump
- S1 = Boiler Supply Sensor 071
- S2 = Mix Supply Sensor 071
- S3 = Outdoor Sensor 070
- V1 = Balancing or Globe Valve

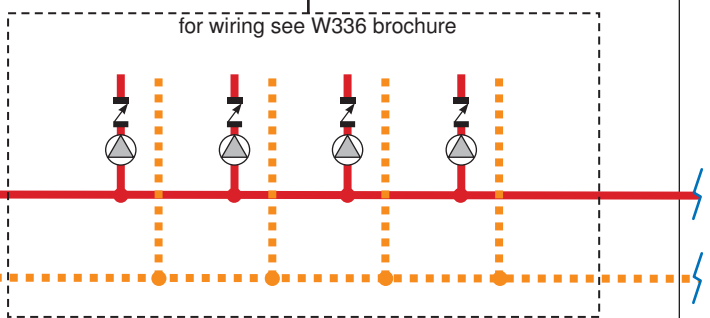
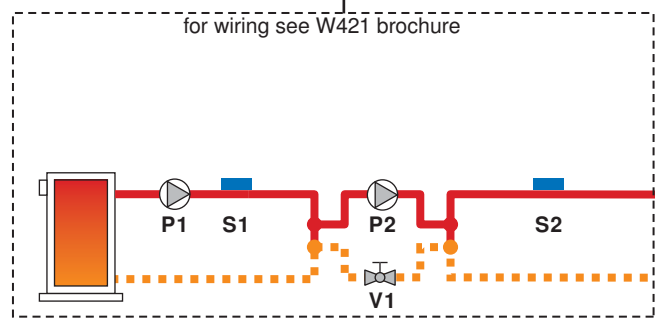
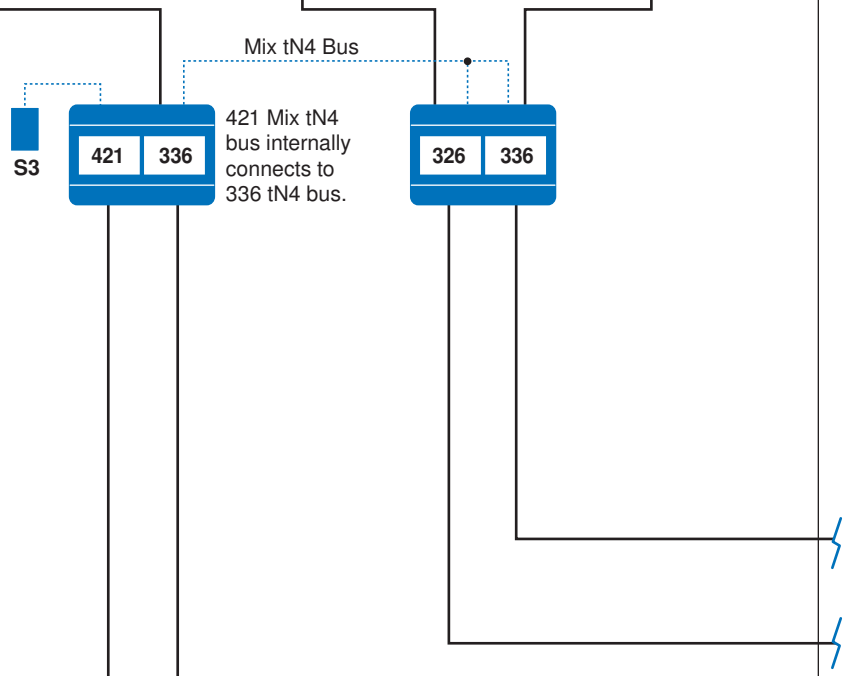
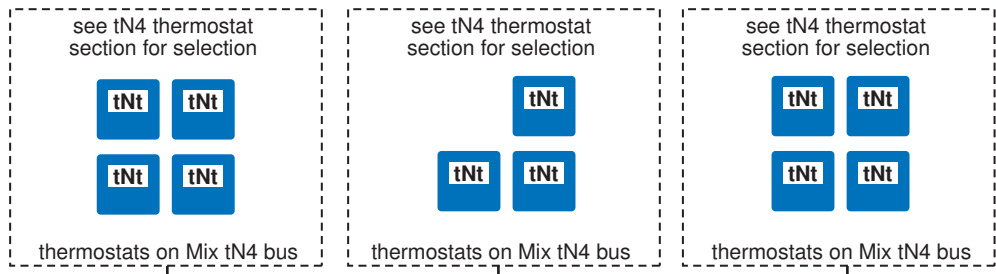



**Concept Drawing:** This is only a concept drawing, not an engineered drawing. It is not intended to describe a complete system, nor any particular system. It is up to the system designer to determine the necessary components for and configuration of the particular system being designed, including additional equipment, isolation relays (for loads greater than the control's specified output ratings), and any safety devices which in the judgement of the designer are appropriate, in order to properly size, configure and design that system and to ensure compliance with building and safety code requirements.

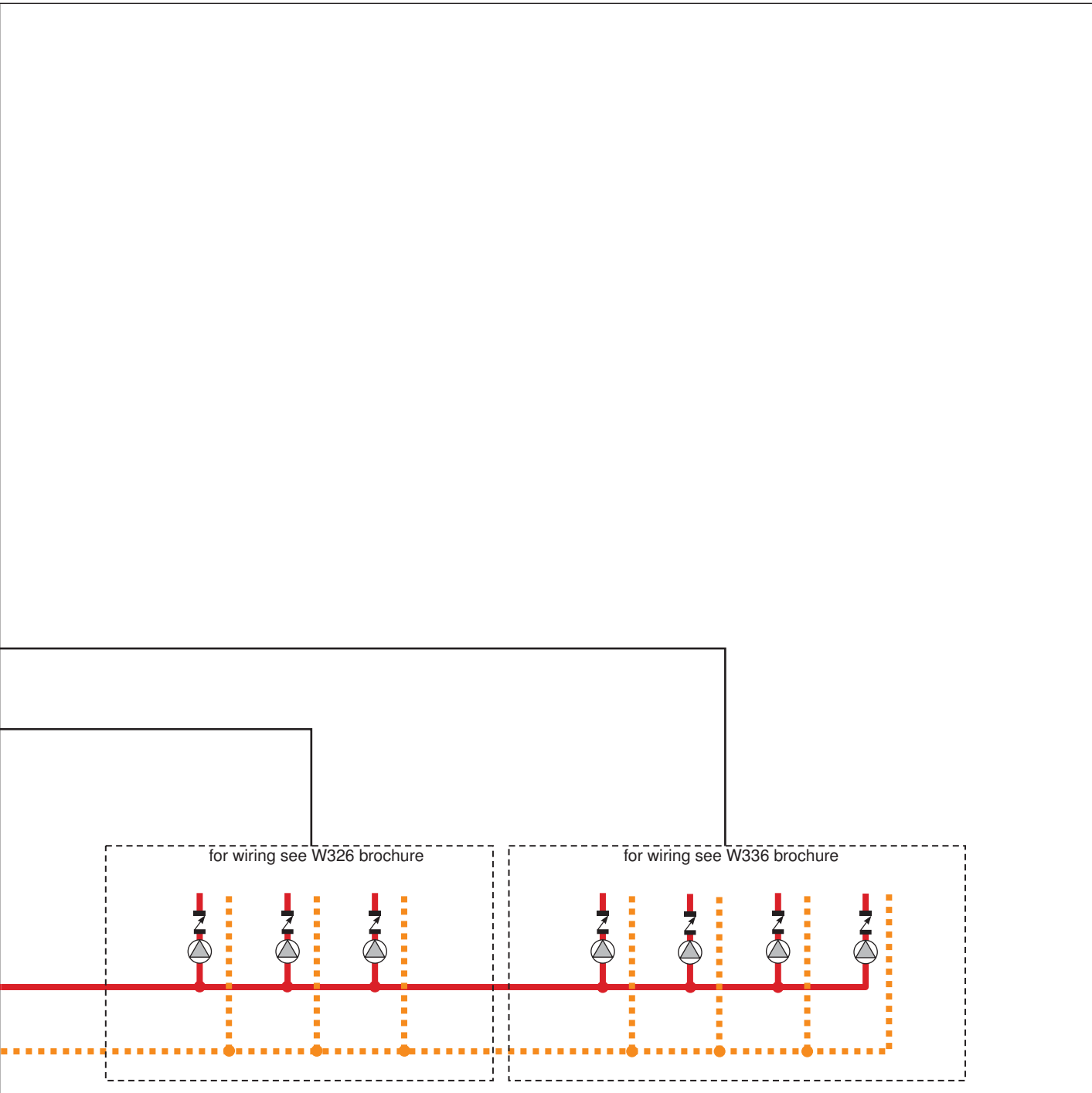

**System Description:** The Mixing Reset Module 421 operates a single on-off boiler and 3-way mixing valve to provide outdoor reset to the heating system. The 3-way mixing valve allows the 421 to provide boiler protection from flue gas condensation. The 421's system pump output operates the boiler pump. Three tekmarNet<sup>®</sup>4 Thermostats operate three zone pumps through a Zone Expansion Module 326. Twelve tekmarNet<sup>®</sup>4 Thermostats operate two groups of six zone valves through two Zone Manager 335s. Each 335 uses its zone group pump output to operate a system pump in order to provide flow through its group of zones. A tekmarNet<sup>®</sup>4 mix bus interconnects the thermostats to the two 335s, the 326, and the 421. This allows the thermostats to communicate with the 421 in order to provide indoor feedback to fine tune the supply water temperature.

**Concept Drawing:** This is only a concept drawing, not an engineered drawing. It is not intended to describe a complete system, nor any particular system. It is up to the system designer to determine the necessary components for and configuration of the particular system being designed, including additional equipment, isolation relays (for loads greater than the control's specified output ratings), and any safety devices which in the judgement of the designer are appropriate, in order to properly size, configure and design that system and to ensure compliance with building and safety code requirements.

**Legend:**

- M1 = Actuating Motor 741
- P1 = Boiler Pump
- P3 = Manifold 1 System Pump
- P4 = Manifold 2 System Pump
- S1 = Boiler Supply Sensor 071
- S2 = Mix Supply Sensor 071
- S3 = Outdoor Sensor 070
- V1 = Mixing Valve 710 to 714
- V2, V3 = Pressure Differential Bypass Valve

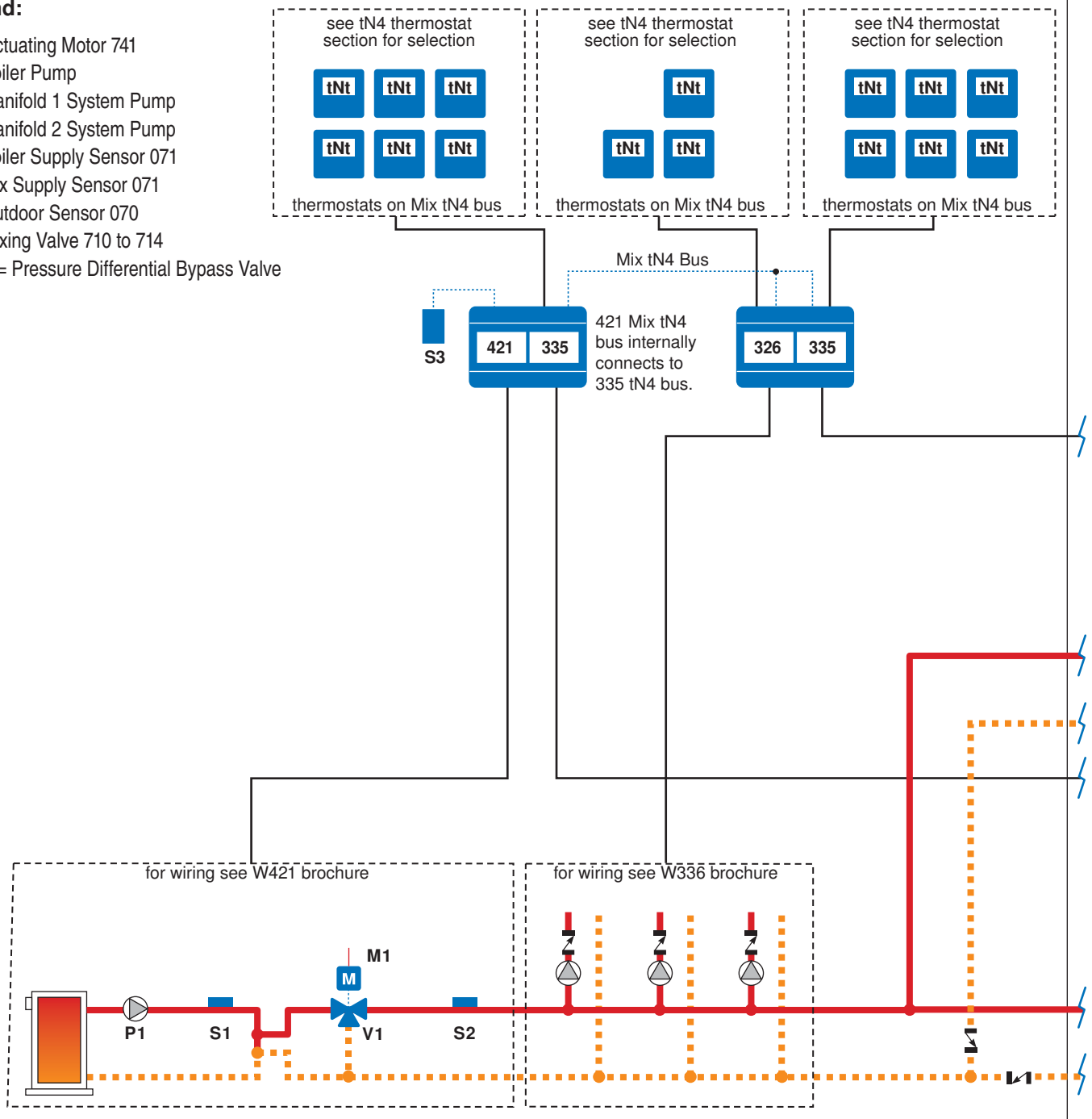

**Concept Drawing:** This is only a concept drawing, not an engineered drawing. It is not intended to describe a complete system, nor any particular system. It is up to the system designer to determine the necessary components for and configuration of the particular system being designed, including additional equipment, isolation relays (for loads greater than the control's specified output ratings), and any safety devices which in the judgement of the designer are appropriate, in order to properly size, configure and design that system and to ensure compliance with building and safety code requirements.

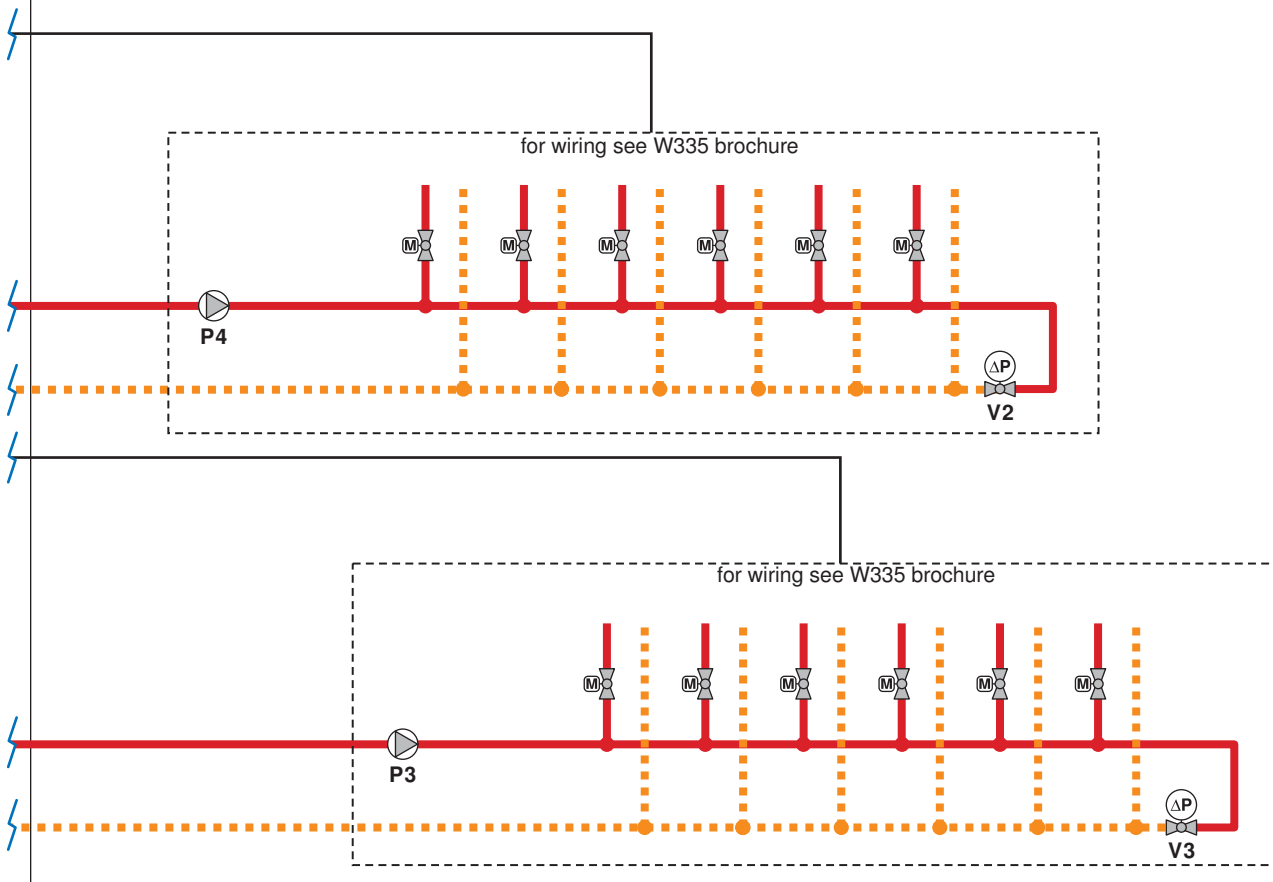

**System Description:** The Mixing Reset Module 421 operates a single on-off boiler and a variable speed injection pump to provide outdoor reset to the heating system. The variable speed injection pump allows the 421 to provide boiler protection from flue gas condensation. The 421's system pump output operates the boiler pump. Four tekmarNet®4 Thermostats operate four zone pumps through the Zone Manager 336. A tekmarNet®4 bus allows the thermostats to communicate to the 421 in order to provide indoor feedback to fine tune the supply water temperature.

**Concept Drawing:** This is only a concept drawing, not an engineered drawing. It is not intended to describe a complete system, nor any particular system. It is up to the system designer to determine the necessary components for and configuration of the particular system being designed, including additional equipment, isolation relays (for loads greater than the control's specified output ratings), and any safety devices which in the judgement of the designer are appropriate, in order to properly size, configure and design that system and to ensure compliance with building and safety code requirements.

**Legend:**

- P1 = Boiler Pump
- P2 = Variable Speed Injection Pump
- S1 = Boiler Supply Sensor 071
- S2 = Mix Supply Sensor 071
- S3 = Outdoor Sensor 070
- V1 = Balancing or Globe Valve

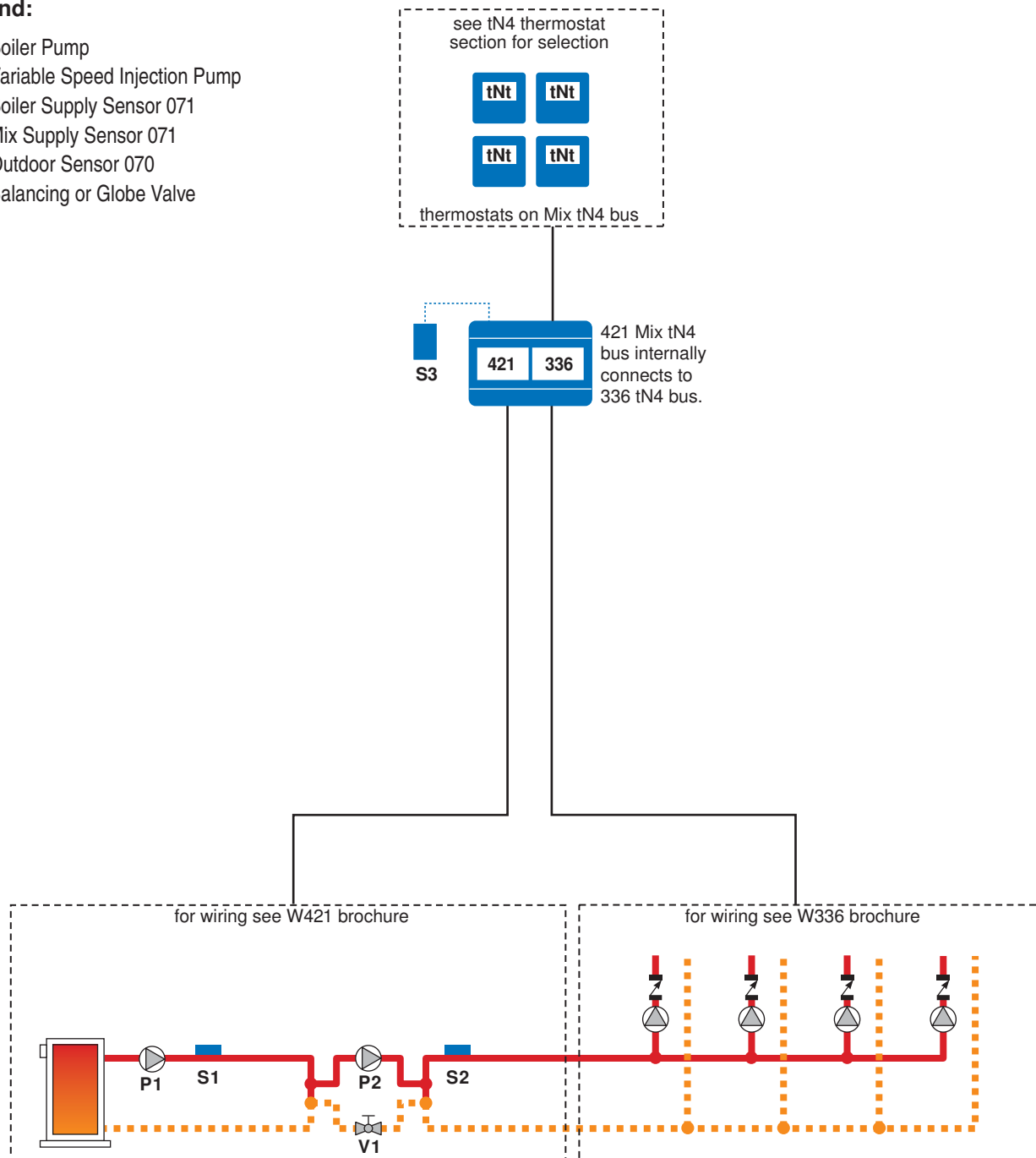

**System Description:** The Universal Reset Module 422 operates a single on-off or modulating boiler to provide outdoor reset to the heating system and overrides the reset temperature to provide indirect domestic hot water tank heating. Priority for the indirect domestic hot water tank is optional. The 422 operates a 4-way mixing valve to provide outdoor reset to the mix temperature heating system and boiler protection from flue gas condensation. Three tekmarNet®4 Thermostats operate three boiler temperature zone valves through group “B” on a Dual Zone Manager 337. A tekmarNet®4 boiler bus interconnects the thermostats to the 337 and the 422. Three tekmarNet®4 Thermostats operate three mix water temperature zone valves through group “A” on a Dual Zone Manager 337. A tekmarNet®4 mix 1 bus interconnects the thermostats to the 337 and the 422. The tekmarNet®4 bus allows the thermostats to provide indoor feedback to fine tune the supply water temperature.

**Concept Drawing:** This is only a concept drawing, not an engineered drawing. It is not intended to describe a complete system, nor any particular system. It is up to the system designer to determine the necessary components for and configuration of the particular system being designed, including additional equipment, isolation relays (for loads greater than the control’s specified output ratings), and any safety devices which in the judgement of the designer are appropriate, in order to properly size, configure and design that system and to ensure compliance with building and safety code requirements.

**Legend:**

- A1 = DHW Aquastat
- M1 = Actuating Motor 741
- P1 = DHW Pump
- P2 = Primary Pump
- P3 = Mix System Pump
- S1 = Boiler Supply Sensor 071
- S2 = Mix Supply Sensor 071
- S3 = Outdoor Sensor 070
- V1 = Mixing Valve 720 to 724
- V2 = Pressure Differential Bypass Valve

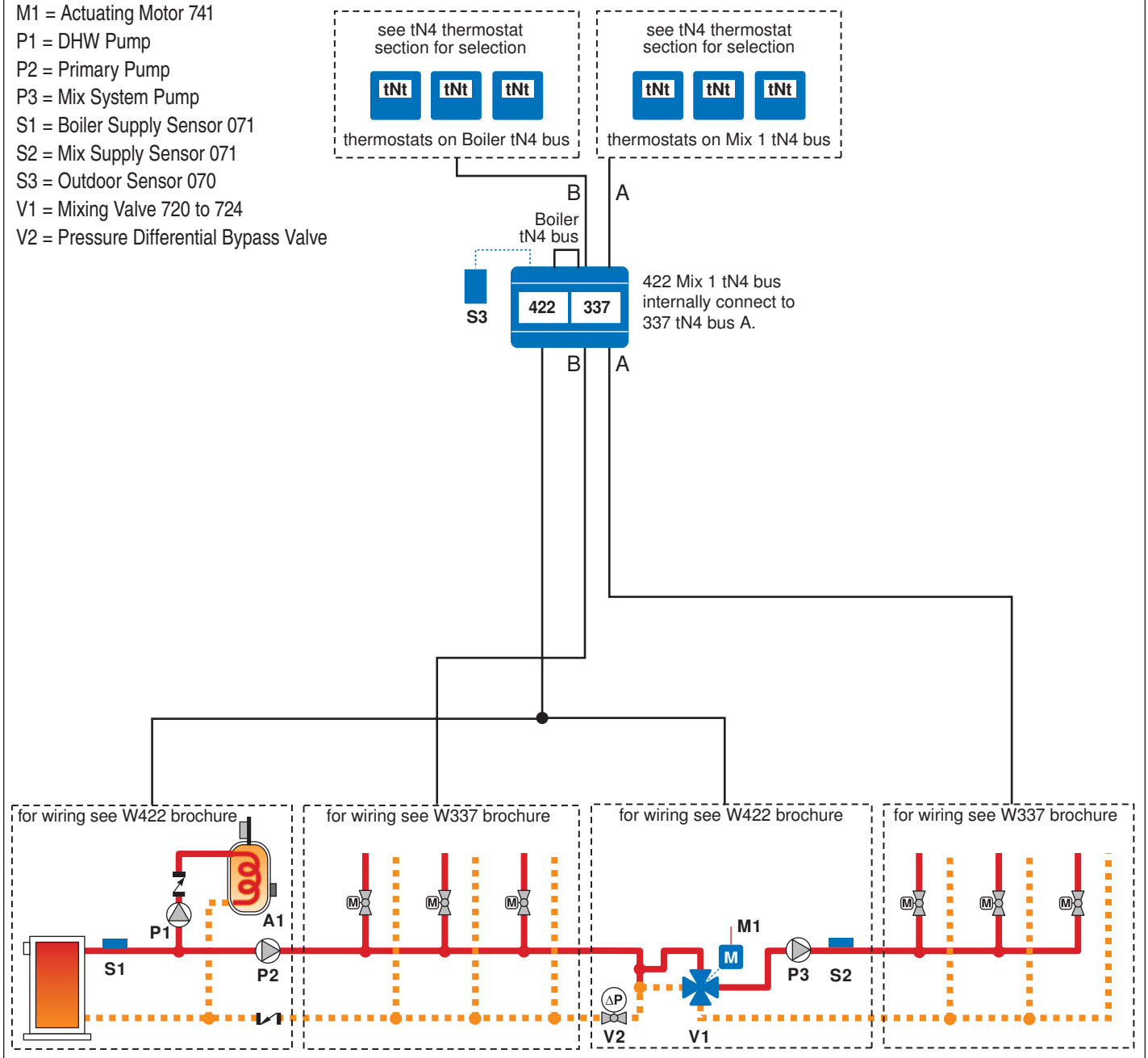

**System Description:** The Universal Reset Module 422 operates a single on-off or modulating boiler to provide outdoor reset to the heating system and overrides the reset temperature to provide indirect domestic hot water tank heating. Priority for the indirect domestic hot water tank is optional. The 422 also operates a 4-way mixing valve to provide outdoor reset to the mix temperature heating system and boiler protection from flue gas condensation. Four tekmarNet<sup>®</sup>4 Thermostats operate four boiler temperature zone pumps through a Zone Manager 336. A tekmarNet<sup>®</sup>4 boiler bus interconnects the thermostats to the 336 and the 422. Six tekmarNet<sup>®</sup>4 Thermostats operate six mix water temperature zone valves through a Zone Manager 335. A tekmarNet<sup>®</sup>4 mix 1 bus interconnects the thermostats to the 335 and the 422. The tekmarNet<sup>®</sup>4 bus allows the thermostats to provide indoor feedback to fine tune the supply water temperature.

**Concept Drawing:** This is only a concept drawing, not an engineered drawing. It is not intended to describe a complete system, nor any particular system. It is up to the system designer to determine the necessary components for and configuration of the particular system being designed, including additional equipment, isolation relays (for loads greater than the control's specified output ratings), and any safety devices which in the judgement of the designer are appropriate, in order to properly size, configure and design that system and to ensure compliance with building and safety code requirements.

**Legend:**

- A1 = DHW Aquastat
- M1 = Actuating Motor 741
- P1 = DHW Pump
- P2 = Primary Pump
- P3 = Mix System Pump
- S1 = Boiler Supply Sensor 071
- S2 = Mix Supply Sensor 071
- S3 = Outdoor Sensor 070
- V1 = Mixing Valve 720 to 724
- V2 = Pressure Differential Bypass Valve

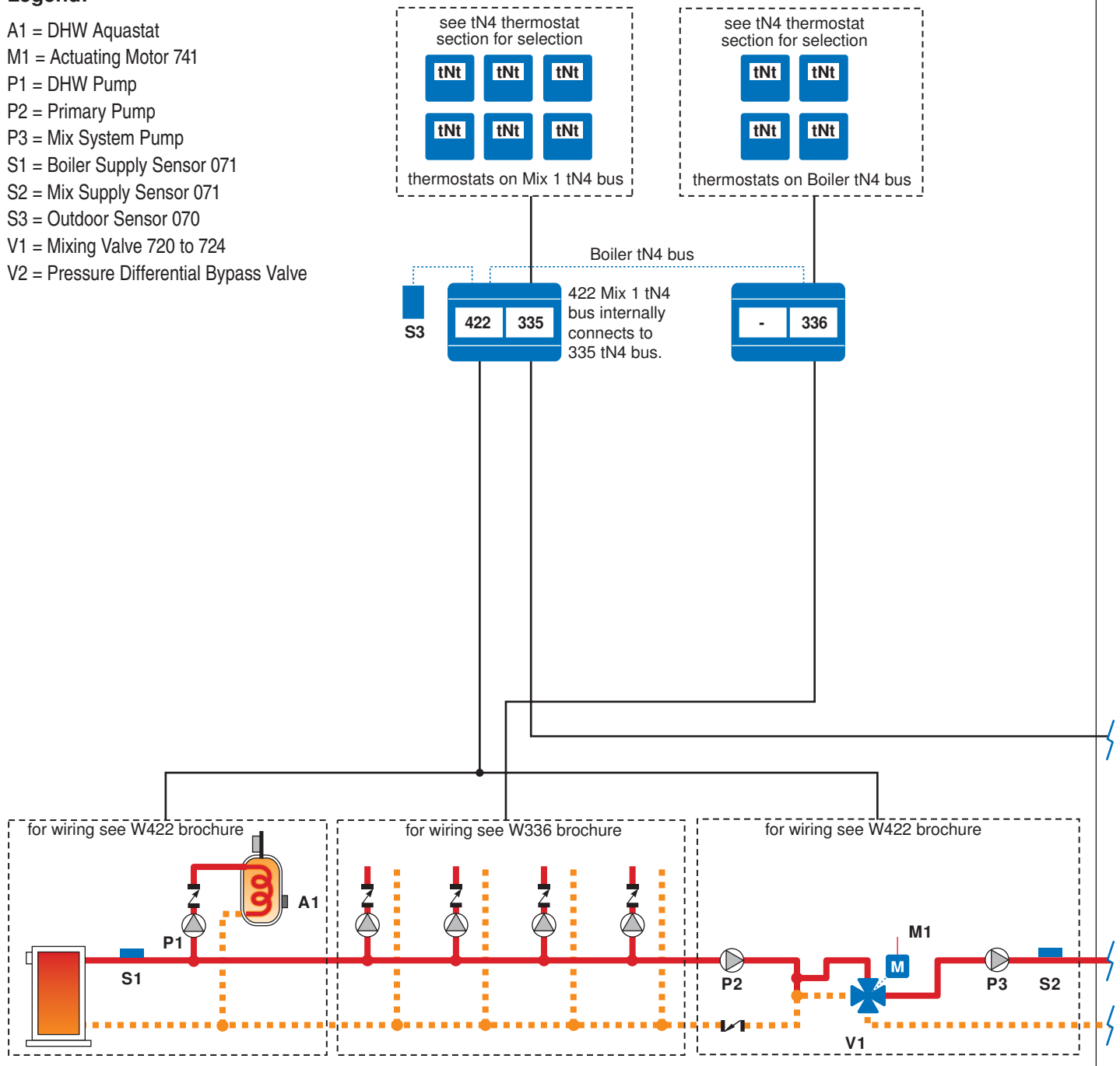

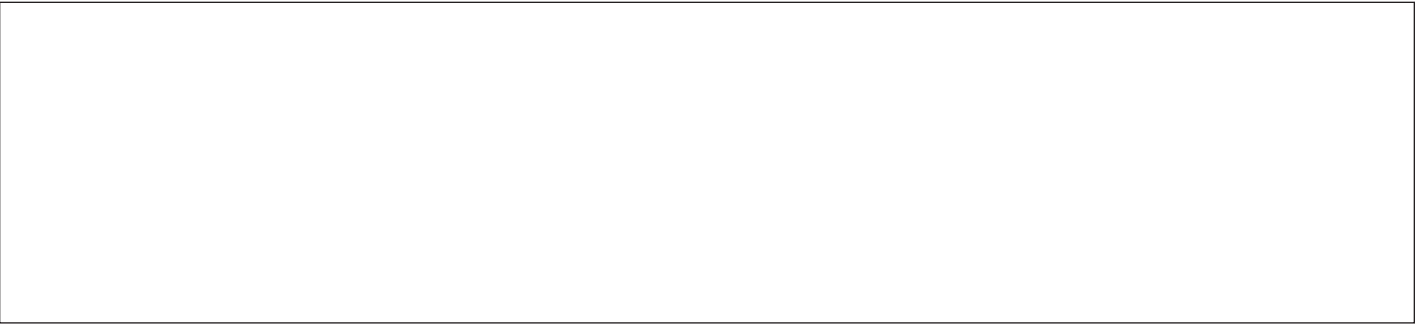

**Concept Drawing:** This is only a concept drawing, not an engineered drawing. It is not intended to describe a complete system, nor any particular system. It is up to the system designer to determine the necessary components for and configuration of the particular system being designed, including additional equipment, isolation relays (for loads greater than the control's specified output ratings), and any safety devices which in the judgement of the designer are appropriate, in order to properly size, configure and design that system and to ensure compliance with building and safety code requirements.

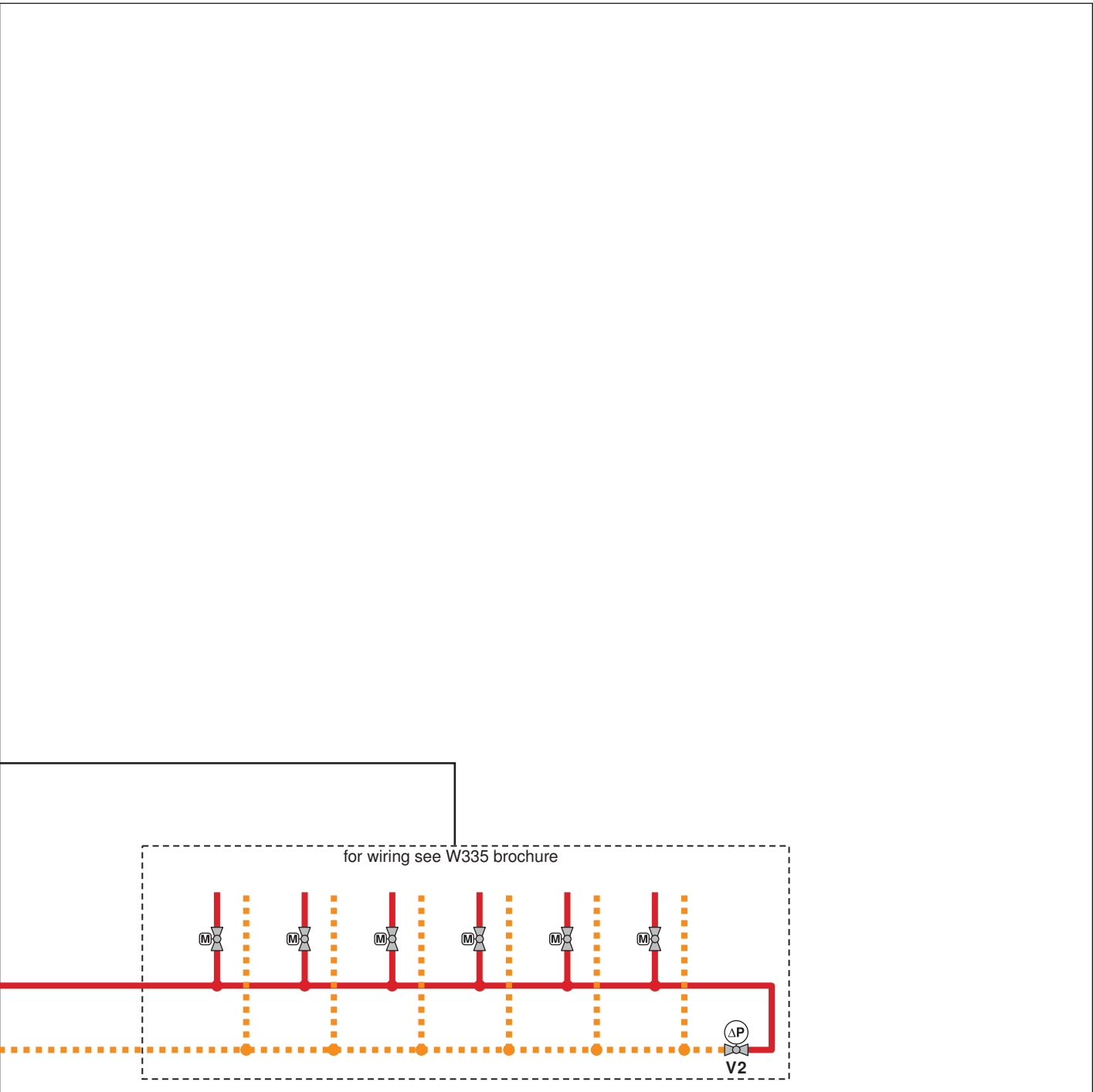

**System Description:** The Universal Reset Module 422 operates a single on-off or modulating boiler to provide outdoor reset to the heating system and overrides the reset temperature to provide indirect domestic hot water tank heating. Priority for the indirect domestic hot water tank is optional. The 422 also operates a variable speed injection pump to provide outdoor reset to the mix temperature heating system and boiler protection from flue gas condensation. Four tekmarNet<sup>®</sup>4 Thermostats operate four boiler temperature zone pumps through a Zone Manager 336. A tekmarNet<sup>®</sup>4 boiler bus interconnects the thermostats to the 336 and the 422. Four tekmarNet<sup>®</sup>4 Thermostats operate four mix water temperature zone pumps through a Zone Manager 336. A tekmarNet<sup>®</sup>4 mix 1 bus interconnects the thermostats to the 336 and the 422. The tekmarNet<sup>®</sup>4 bus allows the thermostats to provide indoor feedback to fine tune the supply water temperature.

**Concept Drawing:** This is only a concept drawing, not an engineered drawing. It is not intended to describe a complete system, nor any particular system. It is up to the system designer to determine the necessary components for and configuration of the particular system being designed, including additional equipment, isolation relays (for loads greater than the control's specified output ratings), and any safety devices which in the judgement of the designer are appropriate, in order to properly size, configure and design that system and to ensure compliance with building and safety code requirements.

**Legend:**

- A1 = DHW Aquastat
- P1 = Primary Pump
- P2 = DHW Pump
- P3 = Variable Speed Injection Pump
- S1 = Boiler Supply Sensor 071
- S2 = Mix Supply Sensor 071
- S3 = Outdoor Sensor 070
- V1 = Balancing or Globe Valve

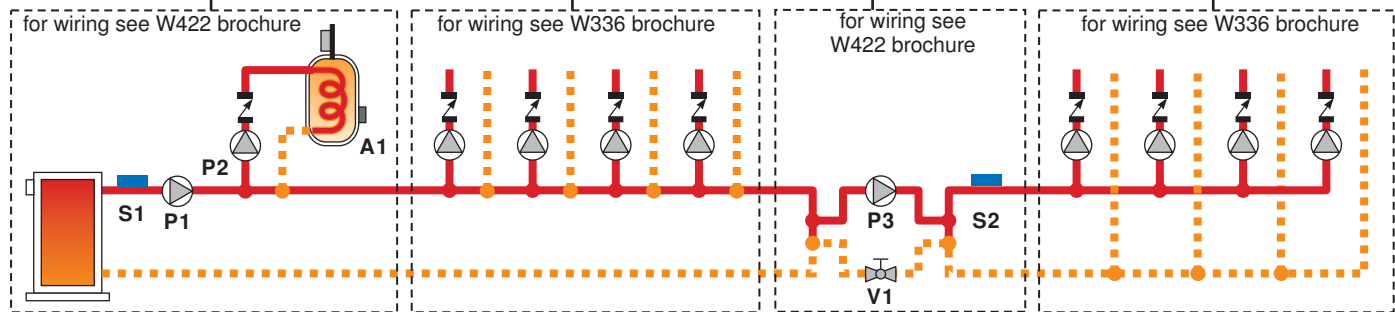
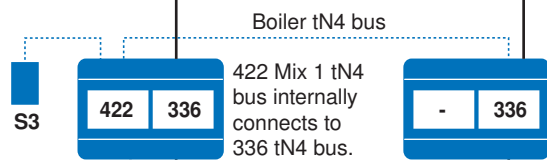
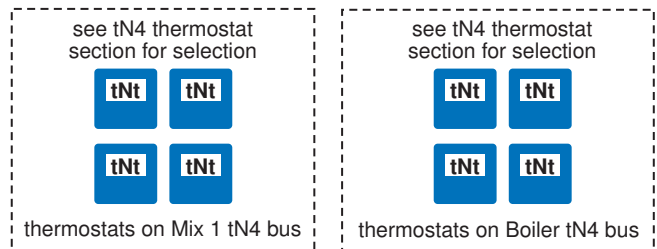

**System Description:** The Universal Reset Module 422 operates a single on-off or modulating boiler to provide load reset to the two mix water systems and overrides the reset temperature to provide indirect domestic hot water tank heating. Priority for the indirect domestic hot water tank is optional. The 422 also operates a 4-way mixing valve to provide outdoor reset to the mix 1 heating system and boiler protection from flue gas condensation. A Mixing Expansion Module 440 operates a second 4-way mixing valve for the mix 2 heating system. Four tekmarNet®4 Thermostats operate four mix 1 temperature zone pumps through a Zone Manager 336. A tekmarNet®4 mix 1 bus interconnects the thermostats to the 336 and the 422. Four tekmarNet®4 Thermostats operate four mix 2 water temperature zone pumps through a Zone Manager 336. A tekmarNet®4 mix 2 bus interconnects the thermostats to the 336 and the 422. The tekmarNet®4 bus allows the thermostats to provide indoor feedback to fine tune the supply water temperature.

**Concept Drawing:** This is only a concept drawing, not an engineered drawing. It is not intended to describe a complete system, nor any particular system. It is up to the system designer to determine the necessary components for and configuration of the particular system being designed, including additional equipment, isolation relays (for loads greater than the control's specified output ratings), and any safety devices which in the judgement of the designer are appropriate, in order to properly size, configure and design that system and to ensure compliance with building and safety code requirements.

**Legend:**

- A1 = DHW Aquastat
- M1, M2 = Actuating Motor 741
- P1 = DHW Pump
- P2 = Primary Pump
- S1 = Boiler Supply Sensor 071
- S2 = Mix 1 Supply Sensor 071
- S3 = Mix 2 Supply Sensor 071
- S4 = Outdoor Sensor 070
- V1, V2 = Globe Valve
- V3, V4 = Mixing Valve 720 to 724

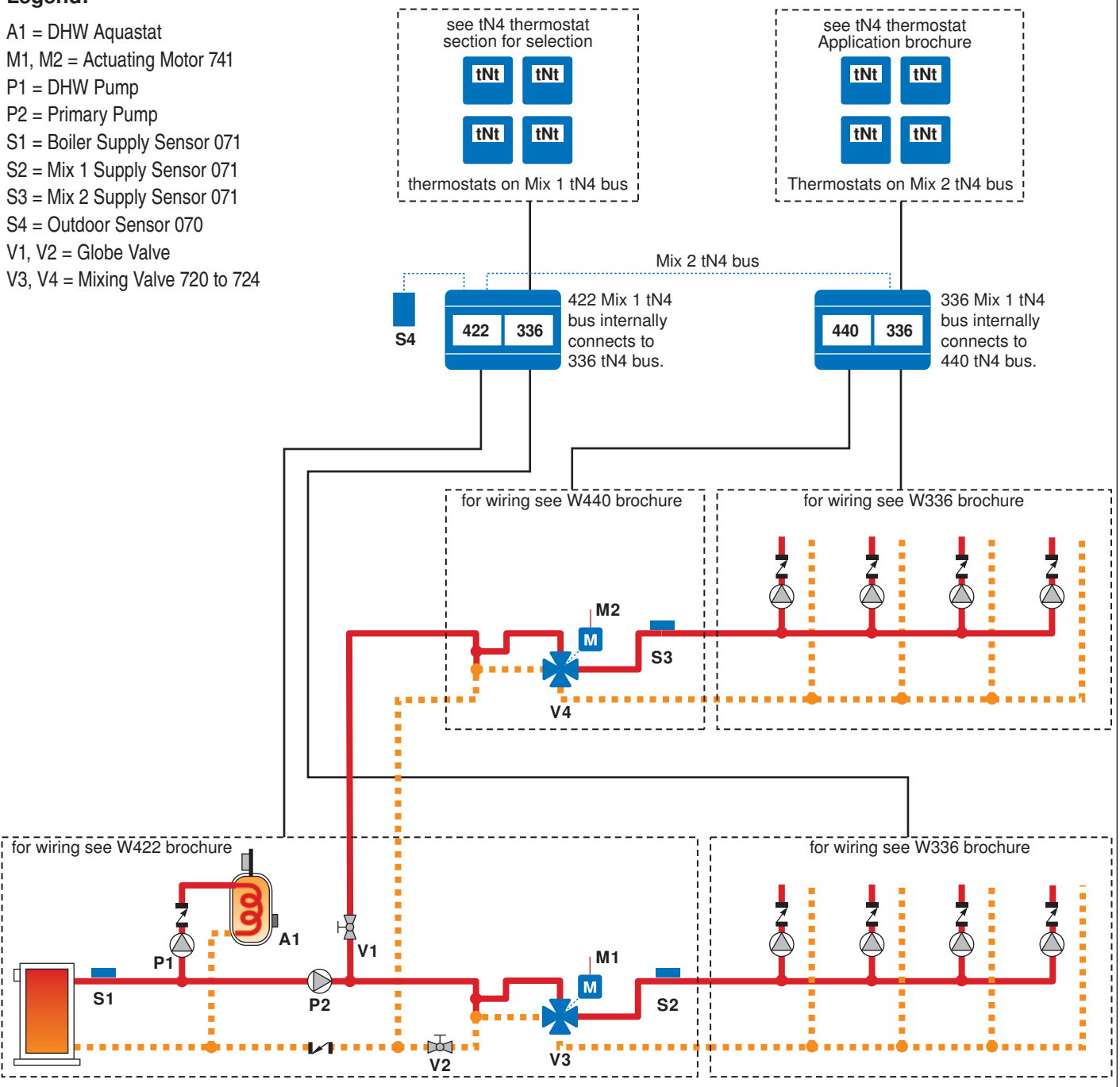

**System Description:** The Universal Reset Module 422 operates a single on-off or modulating boiler to provide outdoor reset to the heating system and overrides the reset temperature to provide indirect domestic hot water tank heating. Priority for the indirect domestic hot water tank is optional. The 422 also operates a 3-way mixing valve to provide outdoor reset to the mix temperature heating system and boiler protection from flue gas condensation. Four tekmarNet®4 Thermostats operate four boiler temperature zone pumps through a Zone Manager 336. A tekmarNet®4 boiler bus interconnects the thermostats to the 336 and the 422. Twelve tekmarNet®4 Thermostats operate twelve mix water temperature zone valves through a Zone Manager 335 and a Zone Expansion Module 325. A tekmarNet®4 mix 1 bus interconnects the thermostats to the 335, the 325, and the 422. The tekmarNet®4 bus allows the thermostats to provide indoor feedback to fine tune the supply water temperature.

**Concept Drawing:** This is only a concept drawing, not an engineered drawing. It is not intended to describe a complete system, nor any particular system. It is up to the system designer to determine the necessary components for and configuration of the particular system being designed, including additional equipment, isolation relays (for loads greater than the control's specified output ratings), and any safety devices which in the judgement of the designer are appropriate, in order to properly size, configure and design that system and to ensure compliance with building and safety code requirements.

**Legend:**

- A1 = DHW Aquastat
- M1 = Actuating Motor 741
- P1 = DHW Pump
- P2 = Primary Pump
- P3 = Mix System Pump
- S1 = Boiler Supply Sensor 071
- S2 = Mix Supply Sensor 071
- S3 = Outdoor Sensor 070
- V1 = Mixing Valve 710 to 714
- V2 = Pressure Differential Bypass Valve

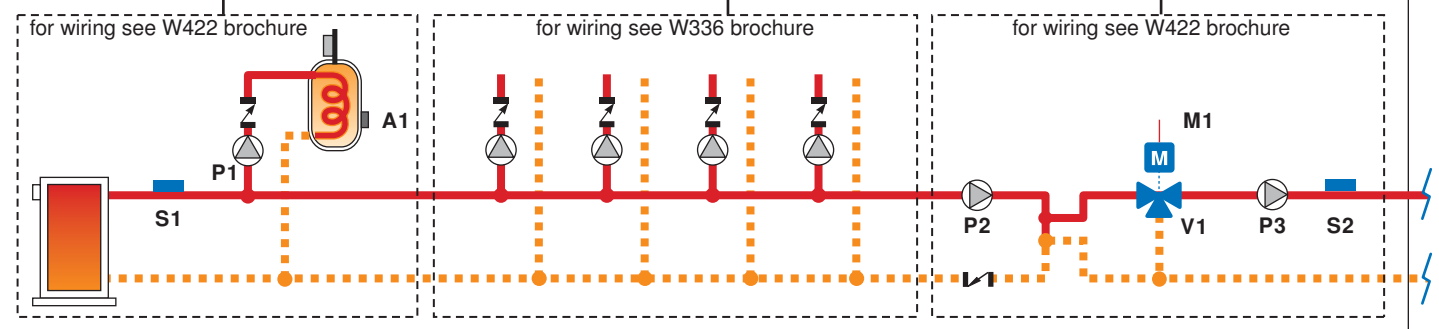
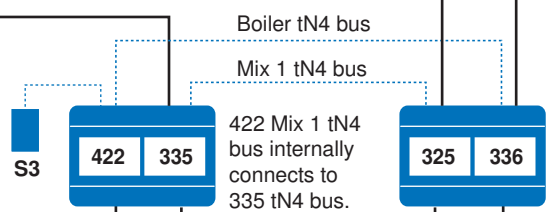
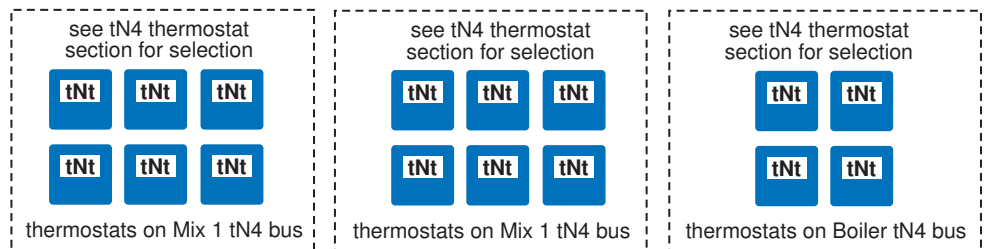



**Concept Drawing:** This is only a concept drawing, not an engineered drawing. It is not intended to describe a complete system, nor any particular system. It is up to the system designer to determine the necessary components for and configuration of the particular system being designed, including additional equipment, isolation relays (for loads greater than the control's specified output ratings), and any safety devices which in the judgement of the designer are appropriate, in order to properly size, configure and design that system and to ensure compliance with building and safety code requirements.

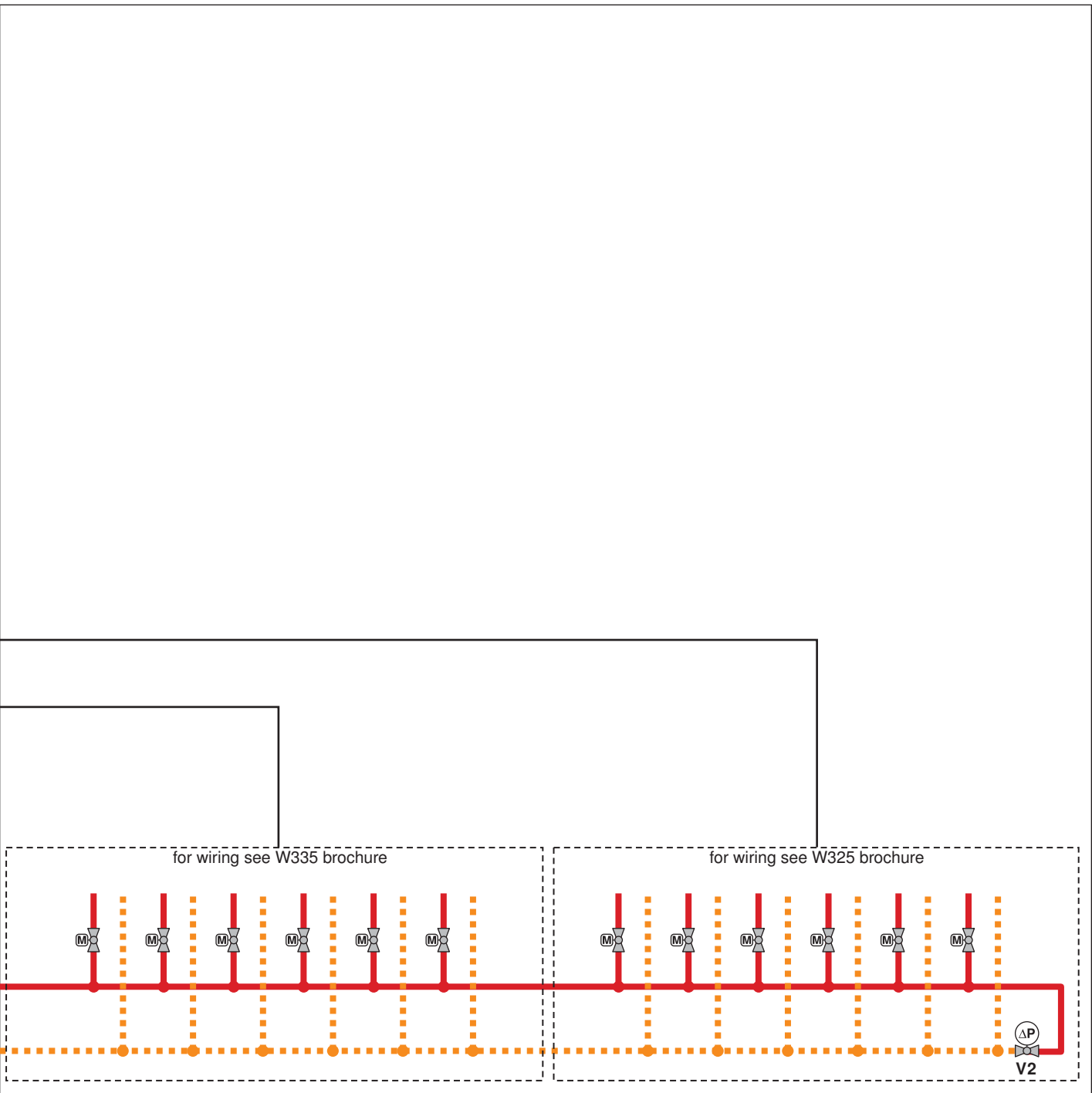

**System Description:** The Universal Reset Module 422 operates a single on-off or modulating boiler to provide outdoor reset to the heating system and overrides the reset temperature to provide indirect domestic hot water tank heating. Priority for the indirect domestic hot water tank is optional. The 422 also operates a variable speed injection pump to provide outdoor reset to the mix temperature heating system and boiler protection from flue gas condensation. Six tekmarNet<sup>®</sup>4 Thermostats operate six boiler temperature zone valves through a Zone Manager 335. A tekmarNet<sup>®</sup>4 boiler bus interconnects the thermostats to the 335 and the 422. Four tekmarNet<sup>®</sup>4 Thermostats operate four mix water temperature zone pumps through a Zone Manager 336. A tekmarNet<sup>®</sup>4 mix 1 bus interconnects the thermostats to the 336 and the 422. The tekmarNet<sup>®</sup>4 bus allows the thermostats to provide indoor feedback to fine tune the supply water temperature.

**Concept Drawing:** This is only a concept drawing, not an engineered drawing. It is not intended to describe a complete system, nor any particular system. It is up to the system designer to determine the necessary components for and configuration of the particular system being designed, including additional equipment, isolation relays (for loads greater than the control's specified output ratings), and any safety devices which in the judgement of the designer are appropriate, in order to properly size, configure and design that system and to ensure compliance with building and safety code requirements.

**Legend:**

- A1 = DHW Aquastat
- P1 = Primary Pump
- P2 = DHW Pump
- P3 = Variable Speed Injection Pump
- S1 = Boiler Supply Sensor 071
- S2 = Mix Supply Sensor 071
- S3 = Outdoor Sensor 070
- V1 = Balancing or Globe Valve
- V2 = Pressure Differential Bypass Valve

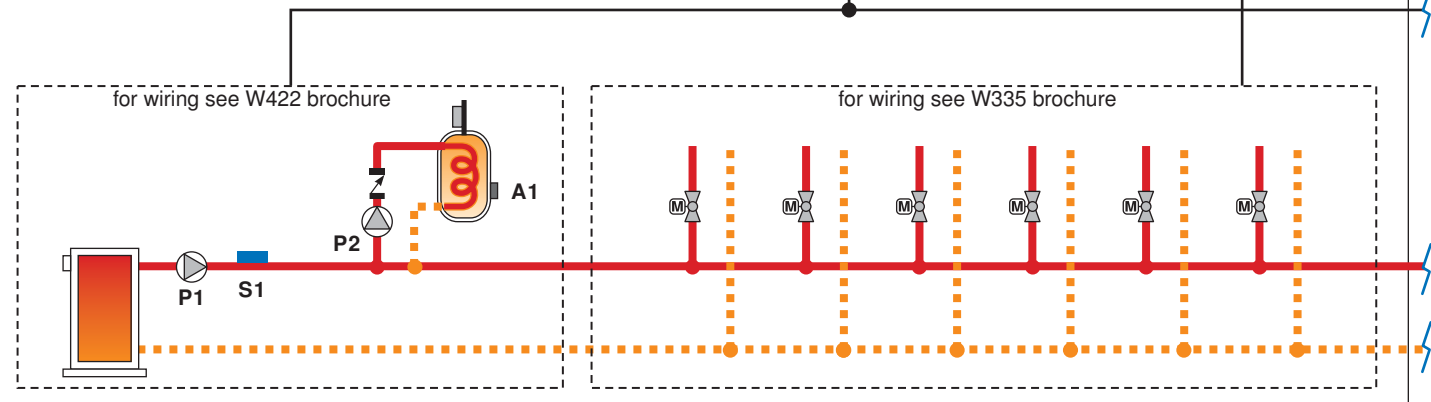
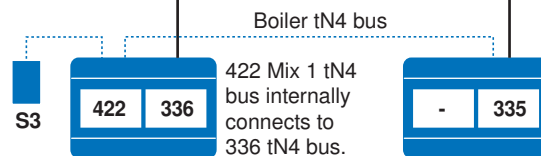
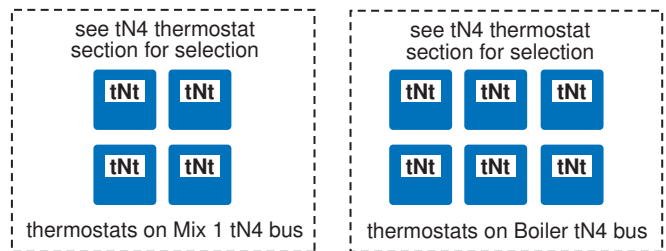

**Concept Drawing:** This is only a concept drawing, not an engineered drawing. It is not intended to describe a complete system, nor any particular system. It is up to the system designer to determine the necessary components for and configuration of the particular system being designed, including additional equipment, isolation relays (for loads greater than the control's specified output ratings), and any safety devices which in the judgement of the designer are appropriate, in order to properly size, configure and design that system and to ensure compliance with building and safety code requirements.

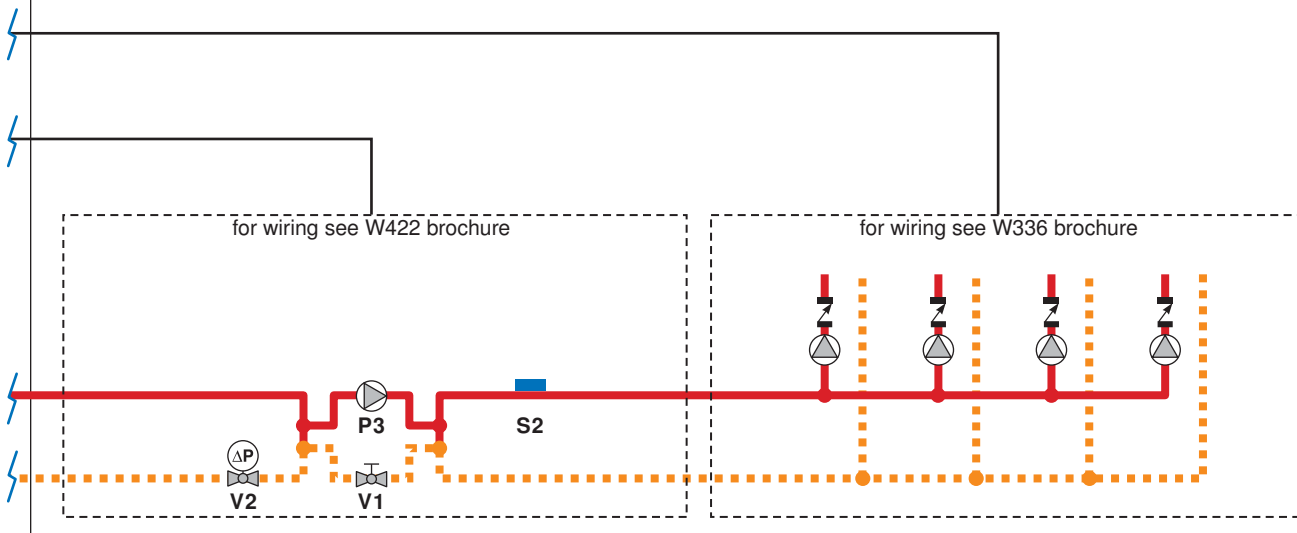

**System Description:** The Universal Reset Module 422 operates a single on-off or modulating boiler to provide outdoor reset to the heating system and overrides the reset temperature to provide indirect domestic hot water tank heating. Priority for the indirect domestic hot water tank is optional. The 422 also operates a 3-way mixing valve to provide outdoor reset to the mix temperature heating system and boiler protection from flue gas condensation. Nine tekmarNet®4 Thermostats operate nine boiler temperature zone valves through group “B” on a Dual Zone Manager 337 and through a Zone Expansion Module 325. A tekmarNet®4 boiler bus interconnects the thermostats to the 337, the 325, and the 422.

(Continued on next page)

**Concept Drawing:** This is only a concept drawing, not an engineered drawing. It is not intended to describe a complete system, nor any particular system. It is up to the system designer to determine the necessary components for and configuration of the particular system being designed, including additional equipment, isolation relays (for loads greater than the control’s specified output ratings), and any safety devices which in the judgement of the designer are appropriate, in order to properly size, configure and design that system and to ensure compliance with building and safety code requirements.

**Legend:**

- A1 = DHW Aquastat
- M1 = Actuating Motor 741
- P1 = DHW Pump
- P2 = Primary Pump
- P3 = Mix System Pump
- S1 = Boiler Supply Sensor 071
- S2 = Mix Supply Sensor 071
- S3 = Outdoor Sensor 070
- V1 = Mixing Valve 710 to 714
- V2, V3 = Pressure Differential Bypass Valve

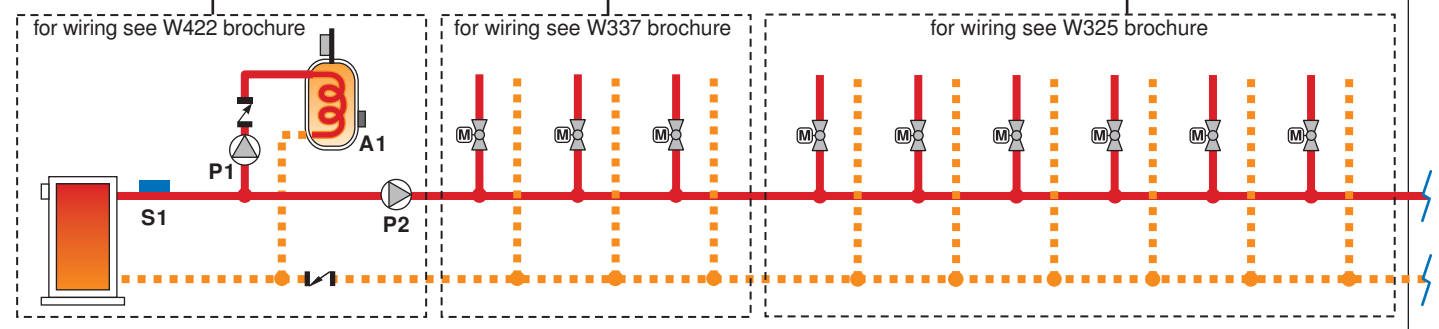
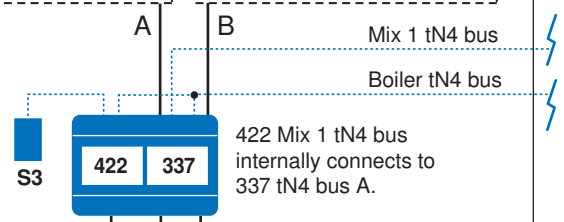
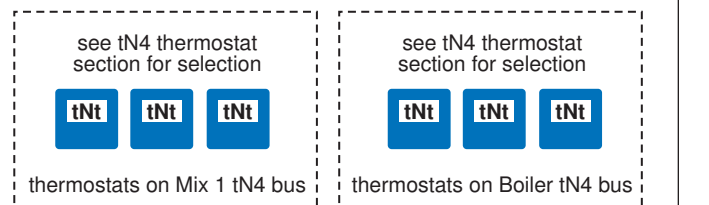

Three tekmarNet<sup>®</sup>4 Thermostats operate three mix water temperature zone valves through group “A” on a Dual Zone Manager 337 and through a Zone Manager 335. A tekmarNet<sup>®</sup>4 mix 1 bus interconnects the thermostats to the 337, the 335, and the 422. The tekmarNet<sup>®</sup>4 bus allows the thermostats to provide indoor feedback to fine tune the supply water temperature.

**Concept Drawing:** This is only a concept drawing, not an engineered drawing. It is not intended to describe a complete system, nor any particular system. It is up to the system designer to determine the necessary components for and configuration of the particular system being designed, including additional equipment, isolation relays (for loads greater than the control’s specified output ratings), and any safety devices which in the judgement of the designer are appropriate, in order to properly size, configure and design that system and to ensure compliance with building and safety code requirements.

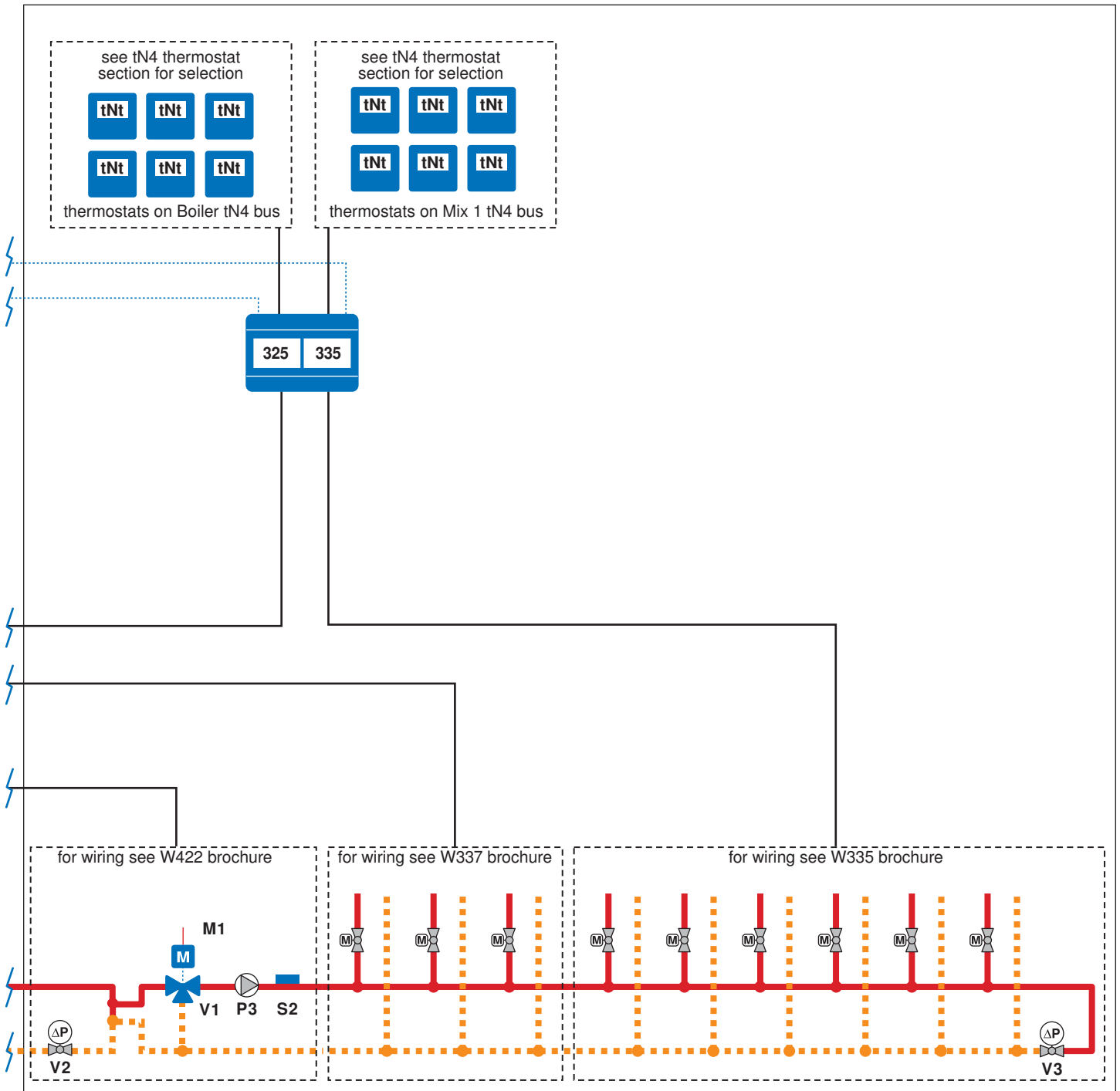

**System Description:** The Universal Reset Module 422 operates a single on-off or modulating boiler to provide load reset to the two mix water systems and overrides the reset temperature to provide indirect domestic hot water tank heating. Priority for the indirect domestic hot water tank is optional. The 422 also operates a variable speed injection pump to provide outdoor reset to the mix 1 heating system and boiler protection from flue gas condensation. A Mixing Expansion Module 440 operates a second variable speed injection pump for the mix 2 heating system. Seven tekmarNet<sup>®</sup>4 Thermostats operate seven mix 1 temperature zone pumps through a Zone Manager 336 and a Zone Expansion Module 326. A Mixing Expansion Module 440 operates a second variable speed injection pump for the mix 2 heating system. Seven tekmarNet<sup>®</sup>4 Thermostats operate seven mix 1 temperature zone pumps through a Zone Manager 336 and a Zone Expansion Module 326. A tekmarNet<sup>®</sup>4 mix 1 bus interconnects the thermostats to the 336, the 326, and the 422.

(Continued on next page)

**Concept Drawing:** This is only a concept drawing, not an engineered drawing. It is not intended to describe a complete system, nor any particular system. It is up to the system designer to determine the necessary components for and configuration of the particular system being designed, including additional equipment, isolation relays (for loads greater than the control's specified output ratings), and any safety devices which in the judgement of the designer are appropriate, in order to properly size, configure and design that system and to ensure compliance with building and safety code requirements.

**Legend:**

- A1 = DHW Aquastat
- P1 = DHW Pump
- P2 = Primary Pump
- P3, P4 = Variable Speed Injection Pump
- S1 = Boiler Supply Sensor 071
- S2 = Mix 1 Supply Sensor 071
- S3 = Mix 2 Supply Sensor 071
- S4 = Outdoor Sensor 070
- V1, ..., V4 = Balancing or Globe Valve

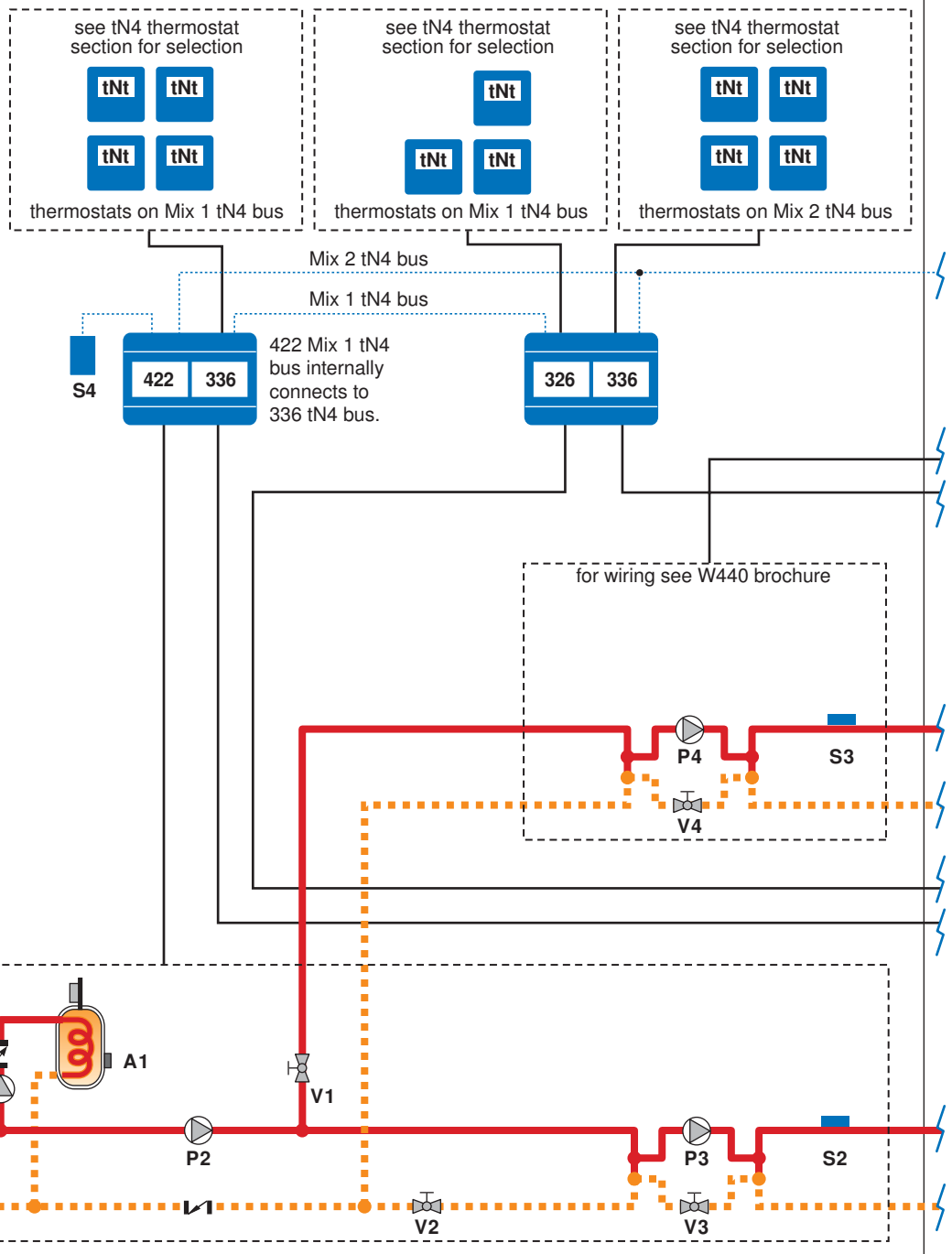

Eight tekmarNet®4 Thermostats operate eight mix 2 water temperature zone pumps through two Zone Manager 336s. A tekmarNet®4 mix 2 bus interconnects the thermostats to the 336s and the 422. The tekmarNet®4 bus allows the thermostats to provide indoor feedback to fine tune the supply water temperature.

**Concept Drawing:** This is only a concept drawing, not an engineered drawing. It is not intended to describe a complete system, nor any particular system. It is up to the system designer to determine the necessary components for and configuration of the particular system being designed, including additional equipment, isolation relays (for loads greater than the control's specified output ratings), and any safety devices which in the judgement of the designer are appropriate, in order to properly size, configure and design that system and to ensure compliance with building and safety code requirements.

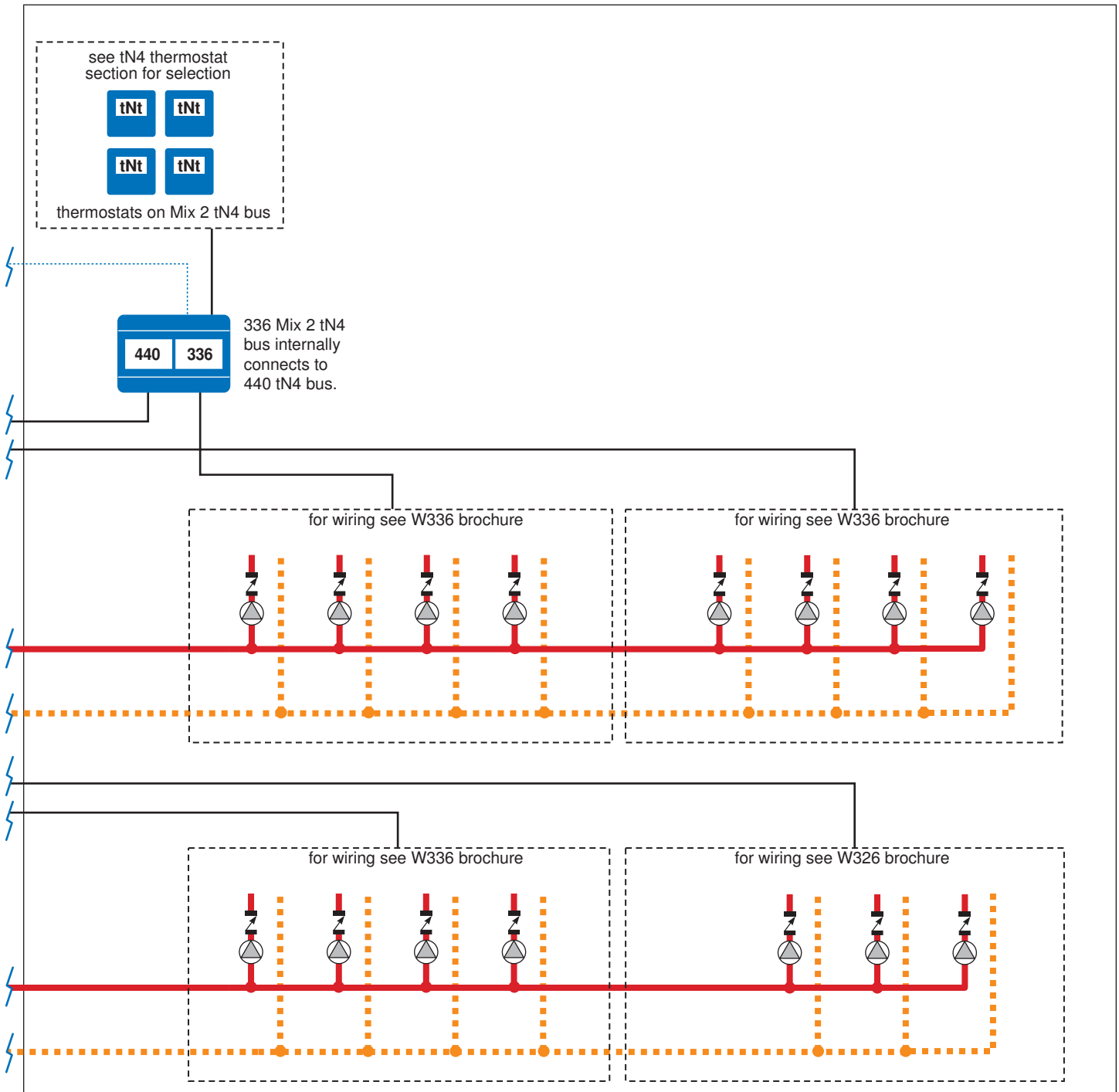

**System Description:** The Universal Reset Module 422 operates a single on-off or modulating boiler to provide load reset to the two mix water systems and overrides the reset temperature to provide indirect domestic hot water tank heating. Priority for the indirect domestic hot water tank is optional. The 422 also operates a variable speed injection pump to provide outdoor reset to the mix 1 heating system and boiler protection from flue gas condensation. A Mixing Expansion Module 440 operates a 4-way mixing valve for the mix 2 heating system. Four tekmarNet®4 Thermostats operate four mix 1 temperature zone pumps through a Zone Manager 336. A tekmarNet®4 mix 1 bus interconnects the thermostats to the 336, and the 422. Six tekmarNet®4 Thermostats operate six mix 2 water temperature zone valves through a Zone Manager 335. A tekmarNet®4 mix 2 bus interconnects the thermostats to the 335 and the 422. The tekmarNet®4 bus allows the thermostats to provide indoor feedback to fine tune the supply water temperature.

**Concept Drawing:** This is only a concept drawing, not an engineered drawing. It is not intended to describe a complete system, nor any particular system. It is up to the system designer to determine the necessary components for and configuration of the particular system being designed, including additional equipment, isolation relays (for loads greater than the control's specified output ratings), and any safety devices which in the judgement of the designer are appropriate, in order to properly size, configure and design that system and to ensure compliance with building and safety code requirements.

**Legend:**

- A1 = DHW Aquastat
- M1 = Actuating Motor 741
- P1 = DHW Pump
- P2 = Primary Pump
- P3 = Variable Speed Injection Pump
- P4 = Mix 2 System Pump
- S1 = Boiler Supply Sensor 071
- S2 = Mix 1 Supply Sensor 071
- S3 = Mix 2 Supply Sensor 071
- S4 = Outdoor Sensor 070
- V1, ..., V3 = Balancing or Globe Valve
- V4 = Mixing Valve 720 to 724
- V5 = Pressure Differential Bypass Valve

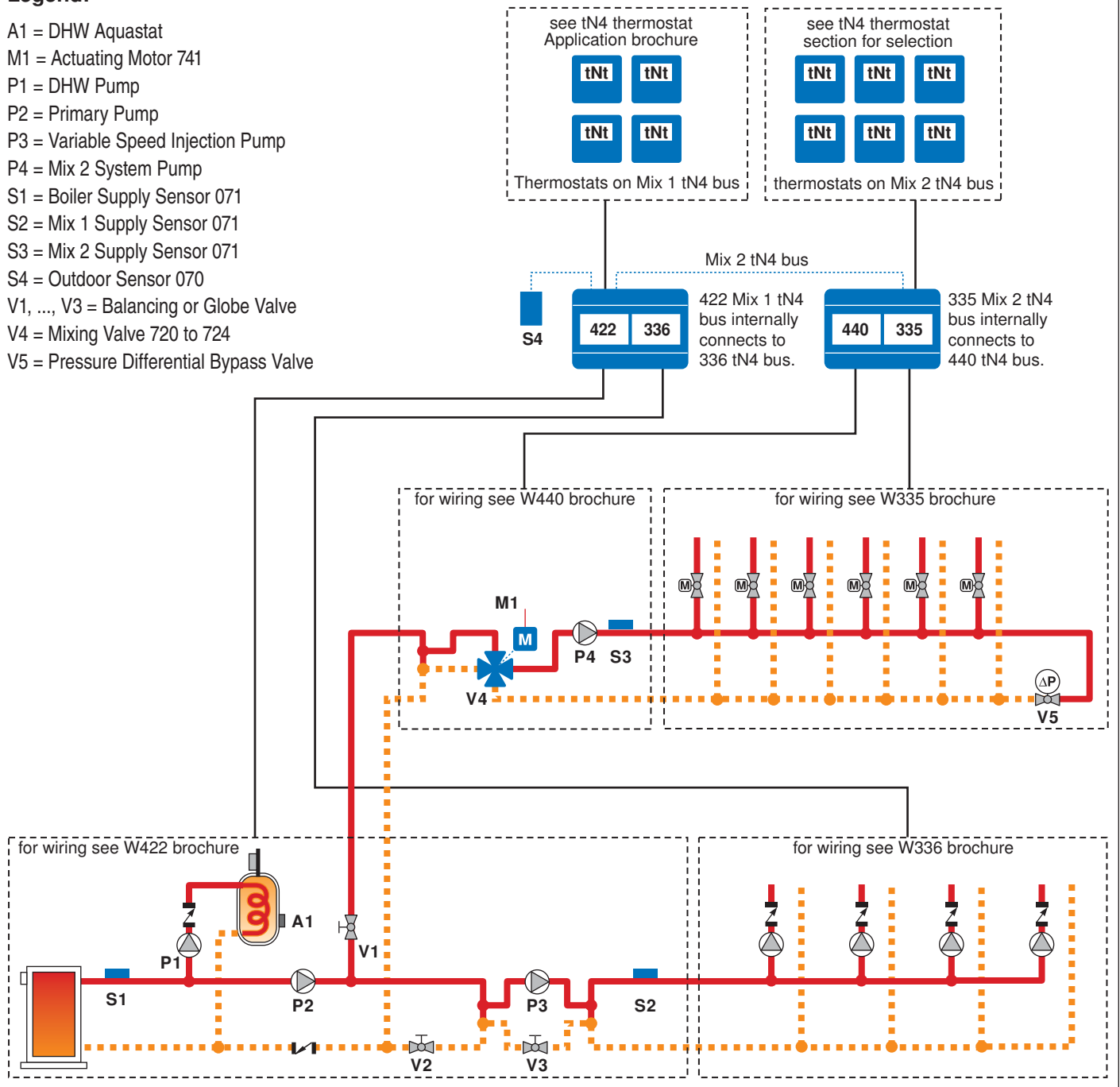

**System Description:** The Universal Reset Module 422 operates a single on-off boiler and a variable speed injection pump to provide outdoor reset to the heating system. The variable speed injection pump allows the 422 to provide boiler protection from flue gas condensation. The 422 is able to heat an indirect domestic hot water tank. Priority for the indirect domestic hot water tank is optional. Four tekmarNet®4 Thermostats operate four zone pumps through the Zone Manager 336. A tekmarNet®4 bus allows the thermostats to communicate to the 422 in order to provide indoor feedback to fine tune the supply water temperature.

**Concept Drawing:** This is only a concept drawing, not an engineered drawing. It is not intended to describe a complete system, nor any particular system. It is up to the system designer to determine the necessary components for and configuration of the particular system being designed, including additional equipment, isolation relays (for loads greater than the control's specified output ratings), and any safety devices which in the judgement of the designer are appropriate, in order to properly size, configure and design that system and to ensure compliance with building and safety code requirements.

**Legend:**

- A1 = DHW Aquastat
- P1 = Primary Pump
- P2 = DHW Pump
- P3 = Variable Speed Injection Pump
- S1 = Boiler Supply Sensor 071
- S2 = Mix Supply Sensor 071
- S3 = Outdoor Sensor 070
- V1 = Balancing or Globe Valve

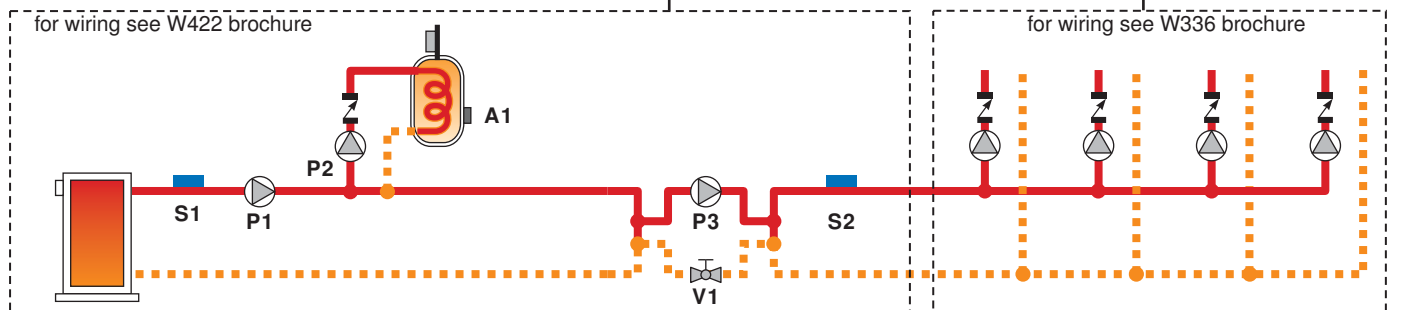
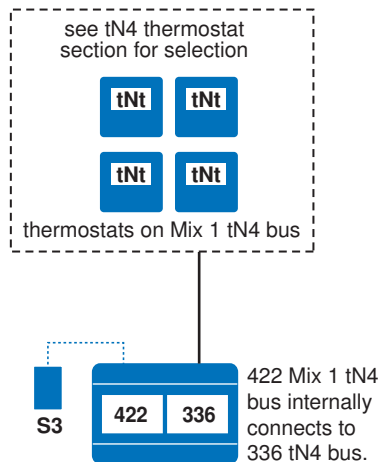

**System Description:** The Universal Reset Module 422 operates a single on-off or modulating boiler to provide load reset to the two mix water systems and overrides the reset temperature to provide indirect domestic hot water tank heating. Priority for the indirect domestic hot water tank is optional. The 422 also operates a variable speed injection pump to provide outdoor reset to the mix 1 heating system and boiler protection from flue gas condensation. A Mixing Expansion Module 440 operates a variable speed injection pump for the mix 2 heating system. Eight tekmarNet<sup>®</sup>4 Thermostats operate eight mix 1 temperature zone pumps through a two Zone Manager 336s. A tekmarNet<sup>®</sup>4 Thermostat operates eight mix 1 temperature zone pumps through a two Zone Manager 336s. A tekmarNet<sup>®</sup>4 mix 1 bus interconnects the thermostats to the 336s, and the 422.

(Continued on next page)

**Concept Drawing:** This is only a concept drawing, not an engineered drawing. It is not intended to describe a complete system, nor any particular system. It is up to the system designer to determine the necessary components for and configuration of the particular system being designed, including additional equipment, isolation relays (for loads greater than the control's specified output ratings), and any safety devices which in the judgement of the designer are appropriate, in order to properly size, configure and design that system and to ensure compliance with building and safety code requirements.

**Legend:**

- A1 = DHW Aquastat
- P1 = DHW Pump
- P2 = Primary Pump
- P3, P4 = Variable Speed Injection Pump
- P5 = Mix 2 System Pump
- S1 = Boiler Supply Sensor 071
- S2 = Mix 1 Supply Sensor 071
- S3 = Mix 2 Supply Sensor 071
- S3 = Outdoor Sensor 070
- V1, ..., V4 = Balancing or Globe Valve
- V5 = Pressure Differential Bypass Valve

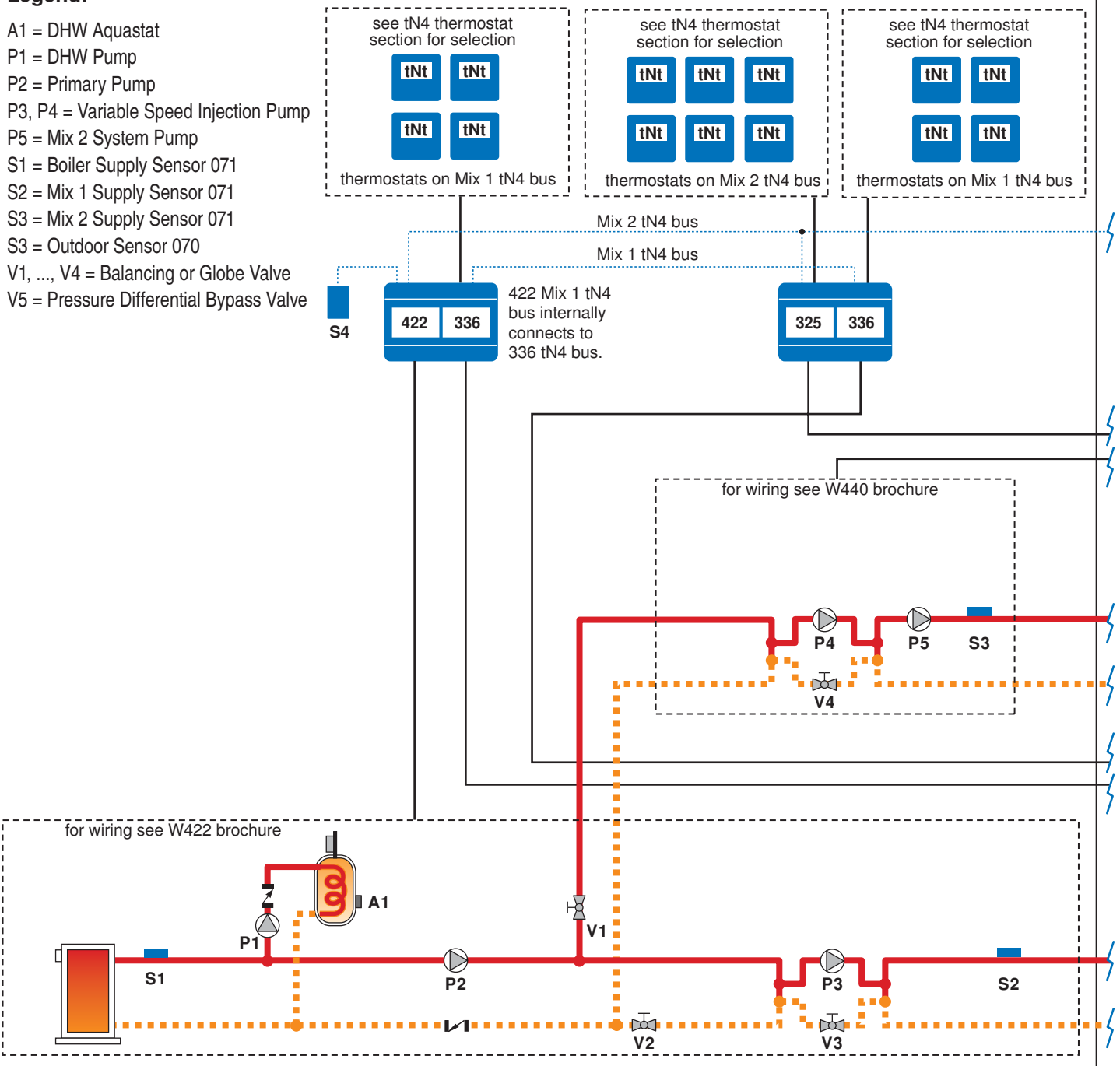

Twelve tekmarNet®4 Thermostats operate twelve mix 2 water temperature zone valves through a Zone Manager 335 and a Zone Expansion Module 325. A tekmarNet®4 mix 2 bus interconnects the thermostats to the 335, the 325, and the 422. The tekmarNet®4 bus allows the thermostats to provide indoor feedback to fine tune the supply water temperature.

**Concept Drawing:** This is only a concept drawing, not an engineered drawing. It is not intended to describe a complete system, nor any particular system. It is up to the system designer to determine the necessary components for and configuration of the particular system being designed, including additional equipment, isolation relays (for loads greater than the control's specified output ratings), and any safety devices which in the judgement of the designer are appropriate, in order to properly size, configure and design that system and to ensure compliance with building and safety code requirements.

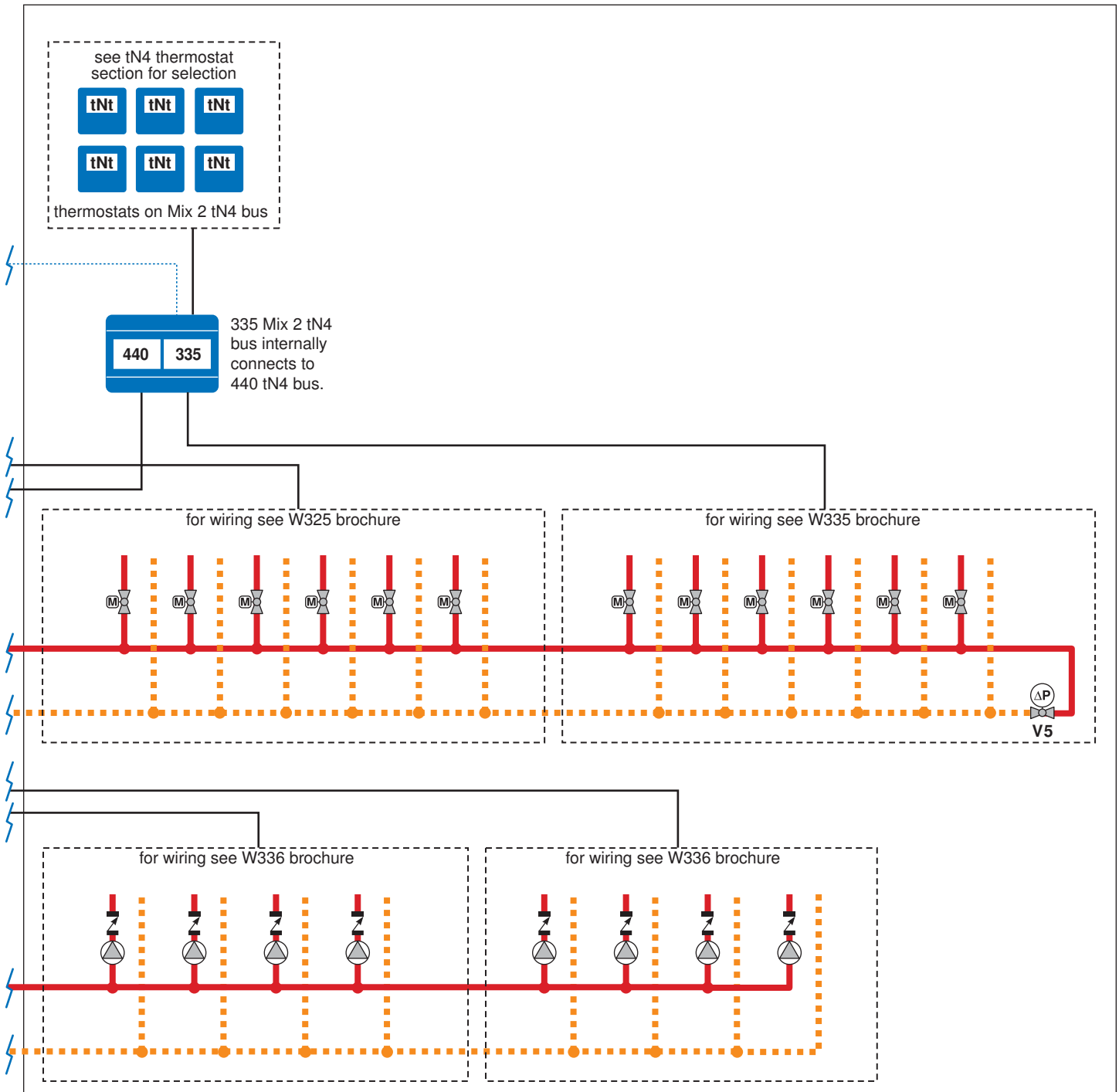

**System Description:** The Universal Reset Module 422 operates a single on-off or modulating boiler to provide load reset to the two mix water systems and overrides the reset temperature to provide indirect domestic hot water tank heating. Priority for the indirect domestic hot water tank is optional. The 422 also operates a 3-way mixing valve to provide outdoor reset to the mix 1 heating system and boiler protection from flue gas condensation. A Mixing Expansion Module 440 operates a 3-way mixing valve for the mix 2 heating system. Twelve tekmarNet®4 Thermostats operate twelve mix 1 temperature zone valves through a Zone Manager 335 and a Zone Expansion Module 325.

(Continued on next page)

**Concept Drawing:** This is only a concept drawing, not an engineered drawing. It is not intended to describe a complete system, nor any particular system. It is up to the system designer to determine the necessary components for and configuration of the particular system being designed, including additional equipment, isolation relays (for loads greater than the control's specified output ratings), and any safety devices which in the judgement of the designer are appropriate, in order to properly size, configure and design that system and to ensure compliance with building and safety code requirements.

**Legend:**

- A1 = DHW Aquastat
- M1, M2 = Actuating Motor 741
- P1 = DHW Pump
- P2 = Primary Pump
- P3 = Mix 1 System Pump
- P4 = Mix 2 System Pump
- S1 = Boiler Supply Sensor 071
- S2 = Mix 1 Supply Sensor 071
- S3 = Mix 2 Supply Sensor 071
- S4 = Outdoor Sensor 070
- V1, V2 = Balancing or Globe Valve
- V3, V4 = Mixing Valve 710 to 714
- V5, V6 = Pressure Differential Bypass Valve

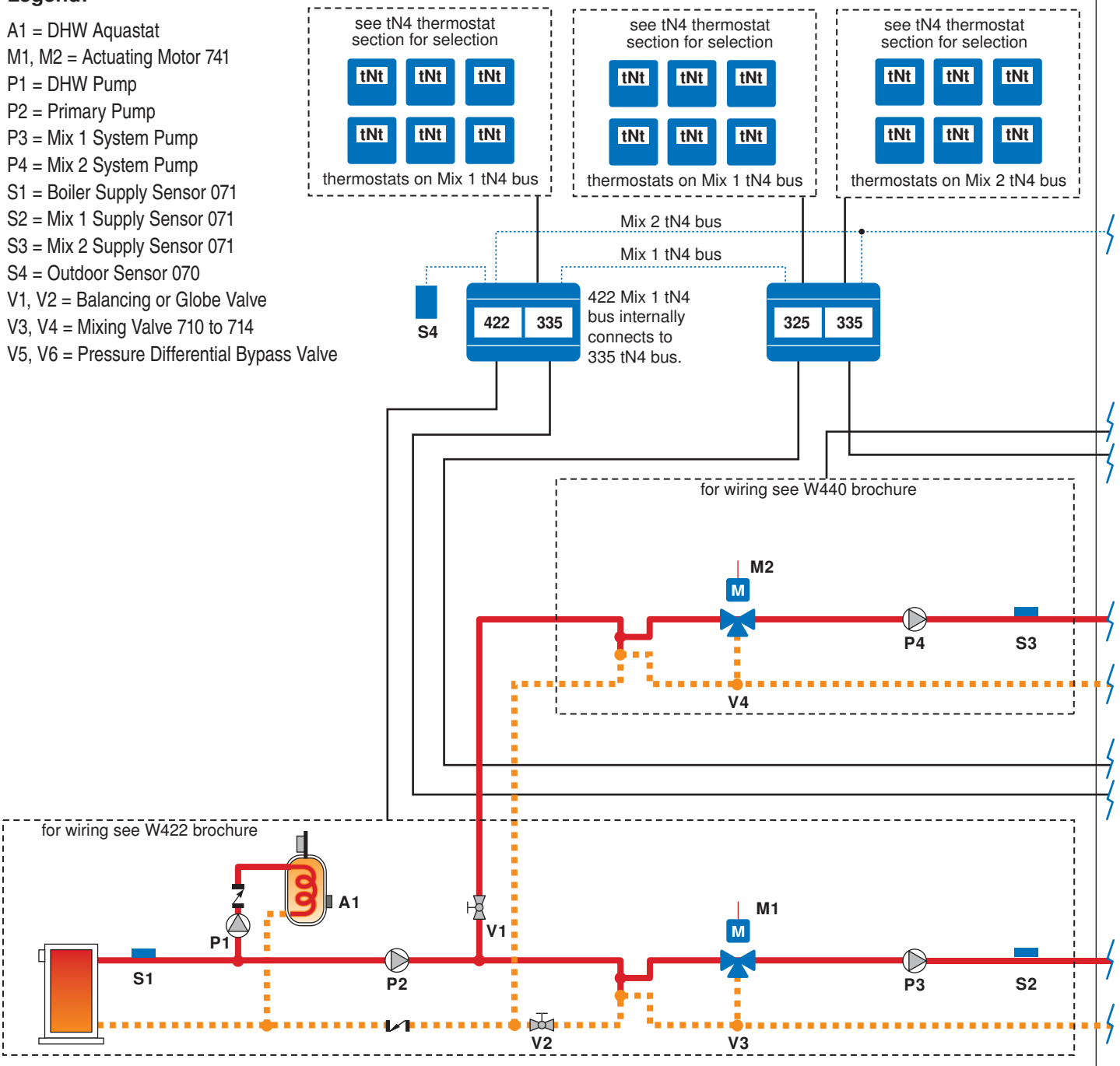

A tekmarNet®4 mix 1 bus interconnects the thermostats to the 335, the 325, and the 422. Twelve tekmarNet®4 Thermostats operate twelve mix 2 water temperature zone valves through two Zone Manager 335s. A tekmarNet®4 mix 2 bus interconnects the thermostats to the 335s and the 422. The tekmarNet®4 bus allows the thermostats to provide indoor feedback to fine tune the supply water temperature.

**Concept Drawing:** This is only a concept drawing, not an engineered drawing. It is not intended to describe a complete system, nor any particular system. It is up to the system designer to determine the necessary components for and configuration of the particular system being designed, including additional equipment, isolation relays (for loads greater than the control's specified output ratings), and any safety devices which in the judgement of the designer are appropriate, in order to properly size, configure and design that system and to ensure compliance with building and safety code requirements.

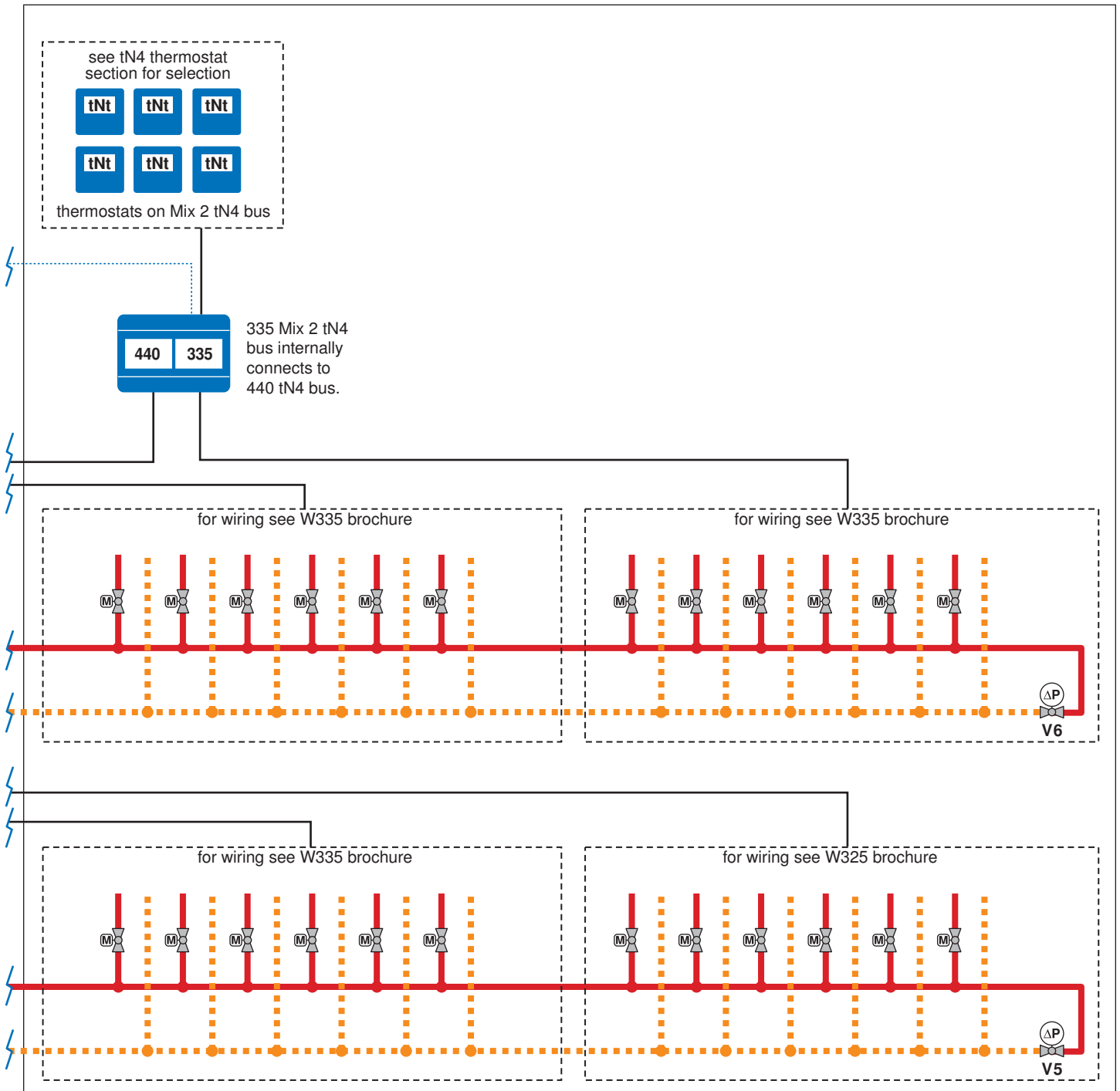

## Application A 423-1

**System Description:** The Universal Reset Module 423 operates two on-off or modulating boilers to provide outdoor reset to the heating system and overrides the reset temperature to provide indirect domestic hot water tank heating. Four tekmarNet<sup>®</sup>4 Thermostats operate four boiler temperature zone pumps through a Zone Manager 336. The 423 connects to 3 Mixing Expansion Modules to provide outdoor reset to mixing zones.

A Mixing Expansion Module 444 operates a variable speed injection pump for the mix 1 heating system. Four tekmarNet<sup>®</sup>4 Thermostats operate four mix 1 zone pumps through a Zone Manager 336.

(Continued on next page)

**Concept Drawing:** This is only a concept drawing, not an engineered drawing. It is not intended to describe a complete system, nor any particular system. It is up to the system designer to determine the necessary components for and configuration of the particular system being designed, including additional equipment, isolation relays (for loads greater than the control's specified output ratings), and any safety devices which in the judgement of the designer are appropriate, in order to properly size, configure and design that system and to ensure compliance with building and safety code requirements.

### Legend:

- A1 = DHW Aquastat
- P1 = DHW Pump
- P2 = Primary Pump
- P3, P4 = Variable Speed Pump
- P5, P6 = Mix Supply Pump
- S1 = Boiler Supply Sensor 071
- S2...S4 = Mix Supply Sensor 071
- S5 = Outdoor Sensor 070
- V1...V5 = Balancing or Globe Valve

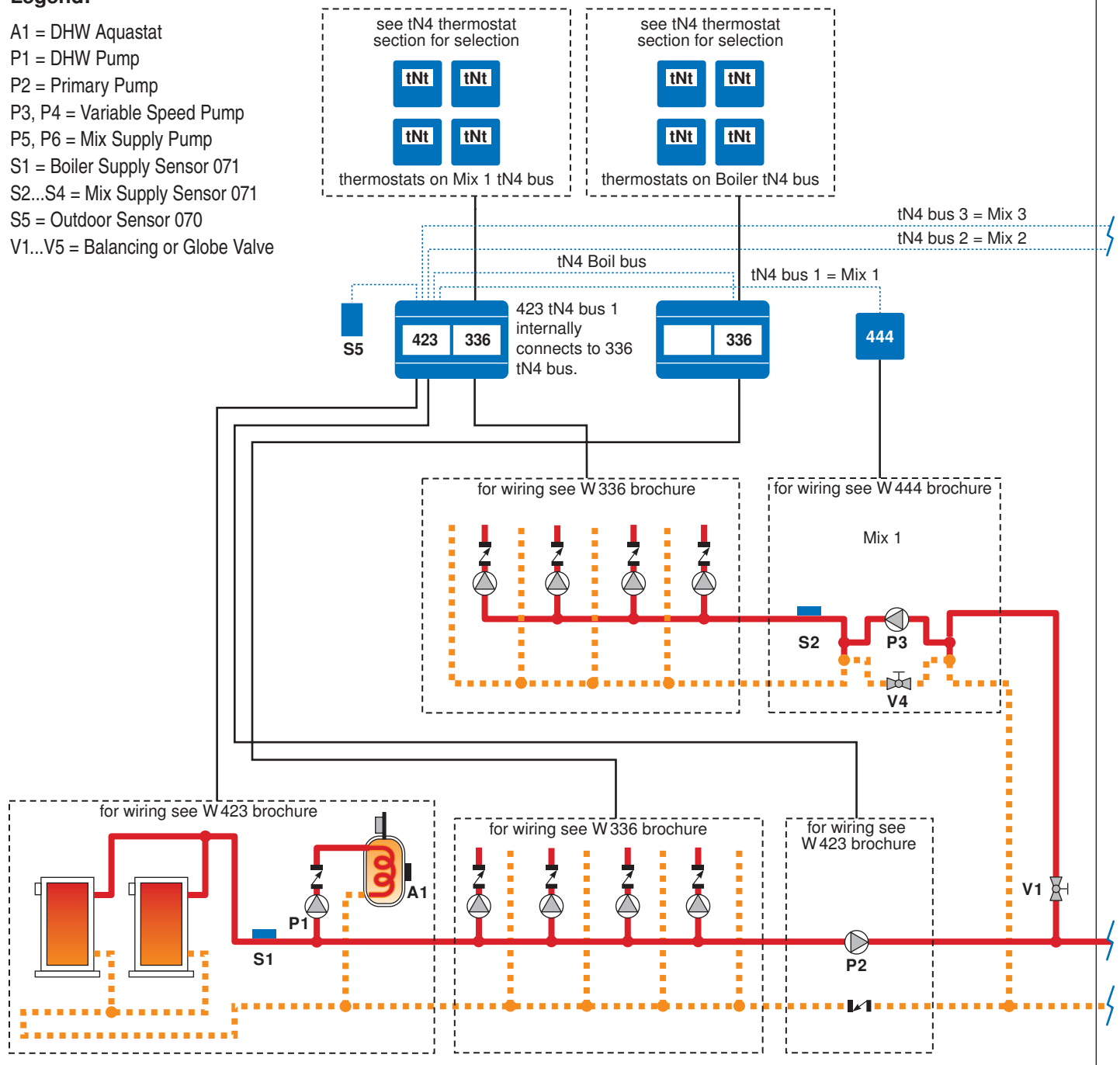

## Application A 423-1

A Mixing Expansion Module 441 operates a 4-way mixing valve for the mix 2 heating system. Six tekmarNet®4 Thermostats operate six mix 2 zone valves through a Zone Manager 335.

A Mixing Expansion Module 440 operates a variable speed injection pump for the mix 3 heating system. Six tekmarNet®4 Thermostats operate six mix 3 zone valves through a Zone Manager 335.

The tekmarNet®4 bus allows the thermostats to provide indoor temperature feedback to fine tune the supply water temperature.

**Concept Drawing:** This is only a concept drawing, not an engineered drawing. It is not intended to describe a complete system, nor any particular system. It is up to the system designer to determine the necessary components for and configuration of the particular system being designed, including additional equipment, isolation relays (for loads greater than the control's specified output ratings), and any safety devices which in the judgement of the designer are appropriate, in order to properly size, configure and design that system and to ensure compliance with building and safety code requirements.

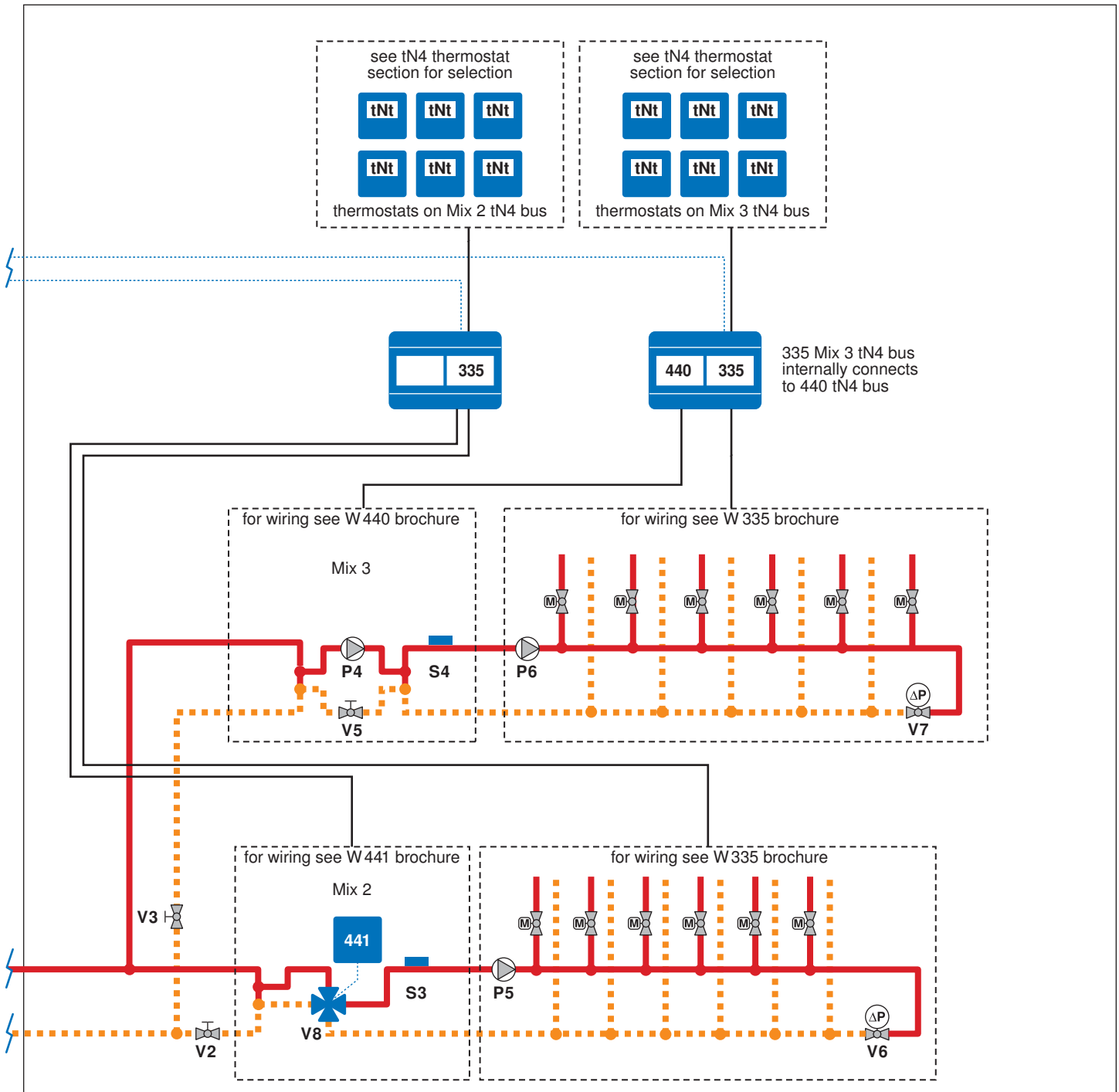

## Application A 423-2

**System Description:** The Universal Reset Module 423 provides a 0 to 10 V (dc) signal to a Boiler Control 268 in order to provide outdoor reset to the heating system and overrides the reset temperature to provide indirect domestic hot water tank heating. The 423 has four tekmarNet®4 buses that are all configured to operate boiler water temperatures. This allows up to 96 tekmarNet®4 Thermostats to be connected to Zone Managers.

The Boiler Control 268 provides staging and rotation to four boilers as well as operating the boiler pumps to provide pre and post purging of the boilers.

**Concept Drawing:** This is only a concept drawing, not an engineered drawing. It is not intended to describe a complete system, nor any particular system. It is up to the system designer to determine the necessary components for and configuration of the particular system being designed, including additional equipment, isolation relays (for loads greater than the control's specified output ratings), and any safety devices which in the judgement of the designer are appropriate, in order to properly size, configure and design that system and to ensure compliance with building and safety code requirements.

### Legend:

A1 = DHW Aquastat  
 P1 = DHW Pump  
 S1, S2 = Boiler Supply Sensor 071  
 S3 = Outdoor Sensor 070

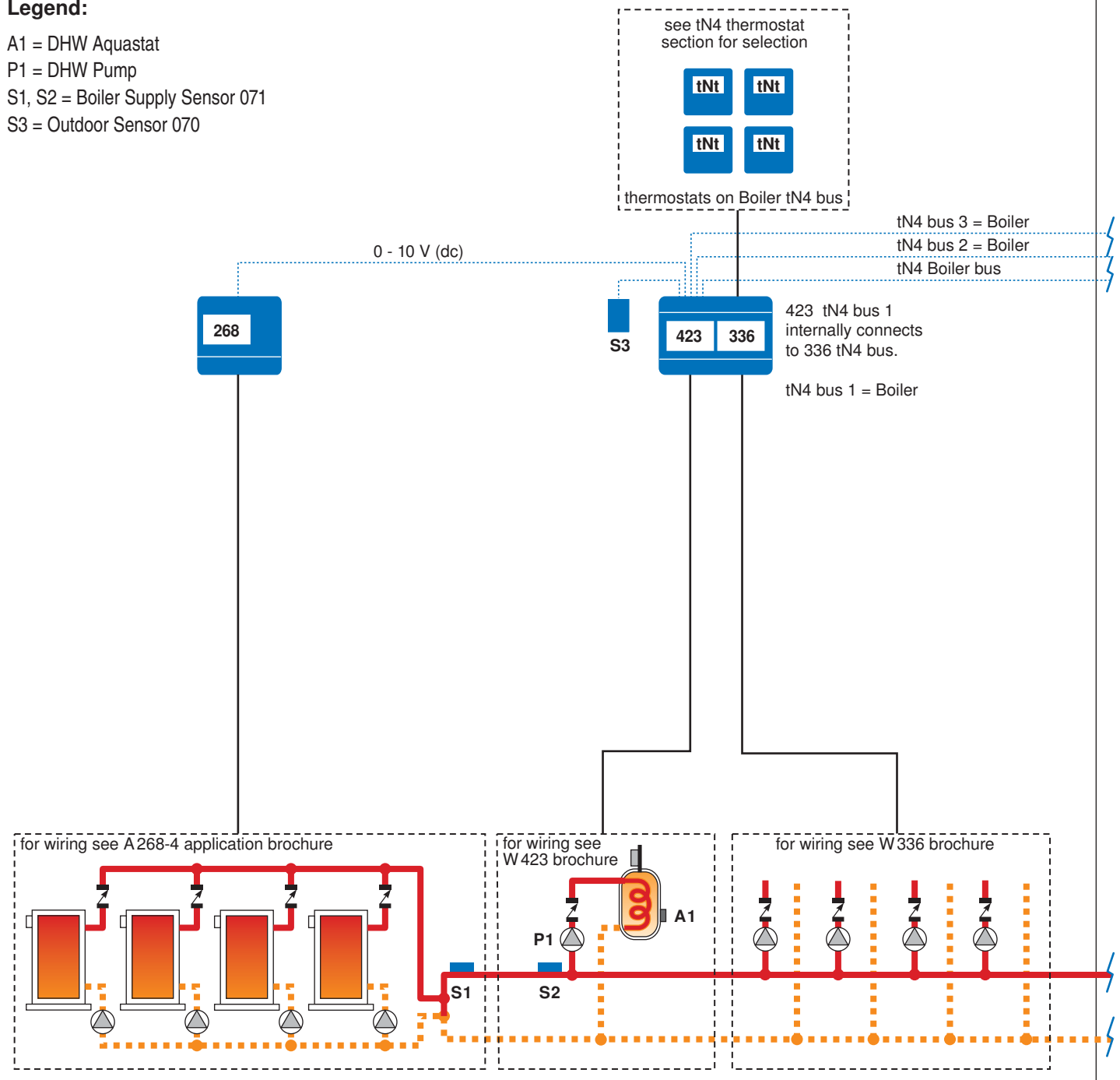

# Application A 423-2

**Concept Drawing:** This is only a concept drawing, not an engineered drawing. It is not intended to describe a complete system, nor any particular system. It is up to the system designer to determine the necessary components for and configuration of the particular system being designed, including additional equipment, isolation relays (for loads greater than the control's specified output ratings), and any safety devices which in the judgement of the designer are appropriate, in order to properly size, configure and design that system and to ensure compliance with building and safety code requirements.

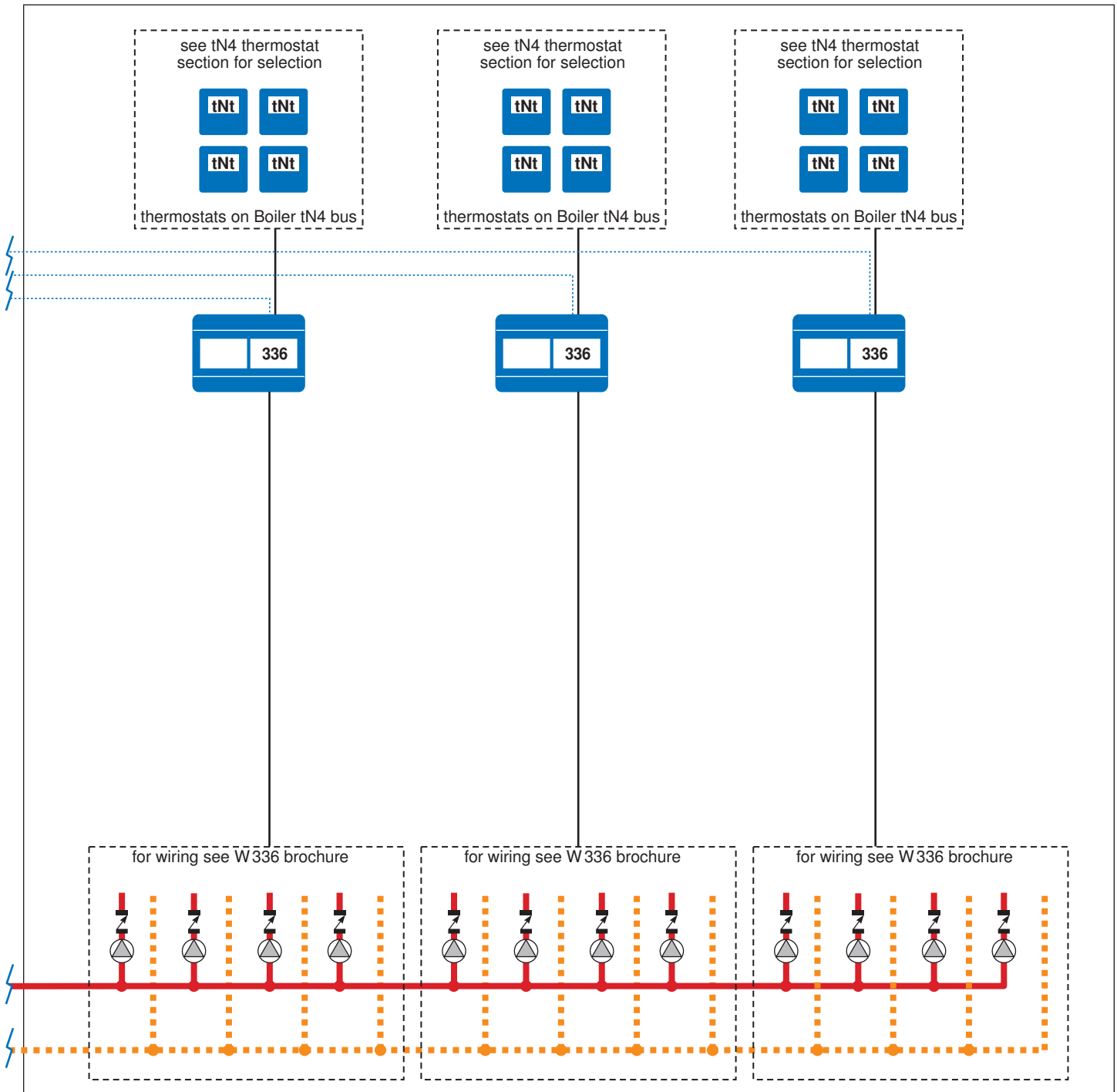

## Application A 423-3

**System Description:** The Universal Reset Module 423 operates two on-off or modulating boilers to provide outdoor reset to the heating system and overrides the reset temperature to provide indirect domestic hot water tank heating. Four tekmarNet®4 Thermostats operate four boiler temperature zone pumps through a Zone Manager 336. The 423 connects to 2 Mixing Expansion Modules to provide outdoor reset to mixing zones.

A Mixing Expansion Module 444 operates a variable speed injection pump for the mix 1 heating system. The mix 1 heating system uses two tN4 buses, Bus 1 and Bus 2 in order to accommodate up to 48 tekmarNet®4 Thermostats connected through Zone Managers.

(Continued on next page)

**Concept Drawing:** This is only a concept drawing, not an engineered drawing. It is not intended to describe a complete system, nor any particular system. It is up to the system designer to determine the necessary components for and configuration of the particular system being designed, including additional equipment, isolation relays (for loads greater than the control's specified output ratings), and any safety devices which in the judgement of the designer are appropriate, in order to properly size, configure and design that system and to ensure compliance with building and safety code requirements.

### Legend:

- A1 = DHW Aquastat
- P1 = DHW Pump
- P2 = Primary Pump
- P3, P4 = Variable Speed Injection Pump
- S1 = Boiler Supply Sensor 071
- S2, S3 = Mix Supply Sensor 071
- S4 = Outdoor Sensor 070
- V1...V4 = Balancing or Globe Valve

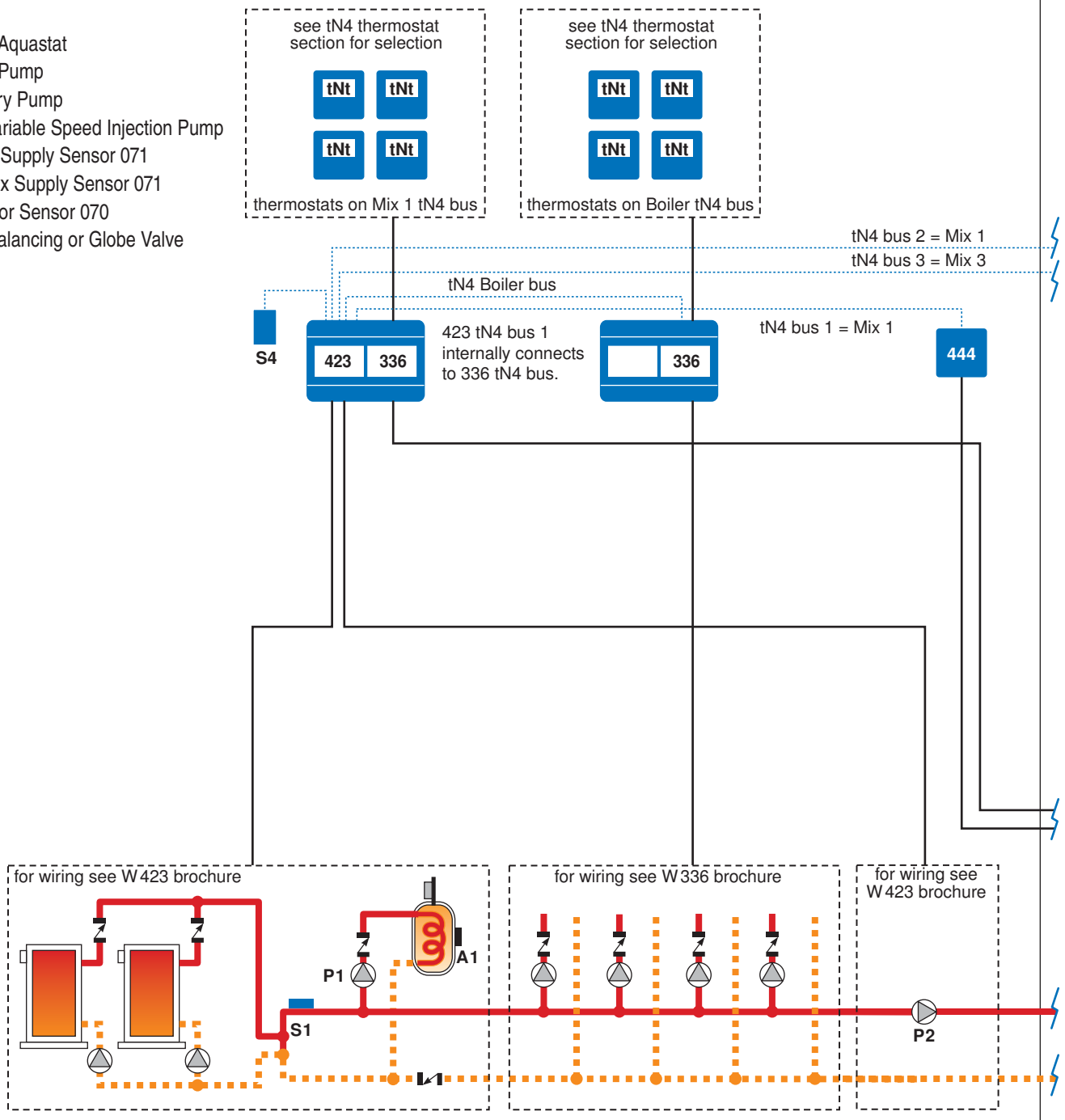

## Application A 423-3

A Mixing Expansion Module 440 operates a variable speed injection pump for the mix 3 heating system. The mix 3 heating system uses tN4 Bus 3. Four tekmarNet<sup>®</sup>4 Thermostats operate four mix 1 zone pumps through a Zone Manager 336.

**Concept Drawing:** This is only a concept drawing, not an engineered drawing. It is not intended to describe a complete system, nor any particular system. It is up to the system designer to determine the necessary components for and configuration of the particular system being designed, including additional equipment, isolation relays (for loads greater than the control's specified output ratings), and any safety devices which in the judgement of the designer are appropriate, in order to properly size, configure and design that system and to ensure compliance with building and safety code requirements.

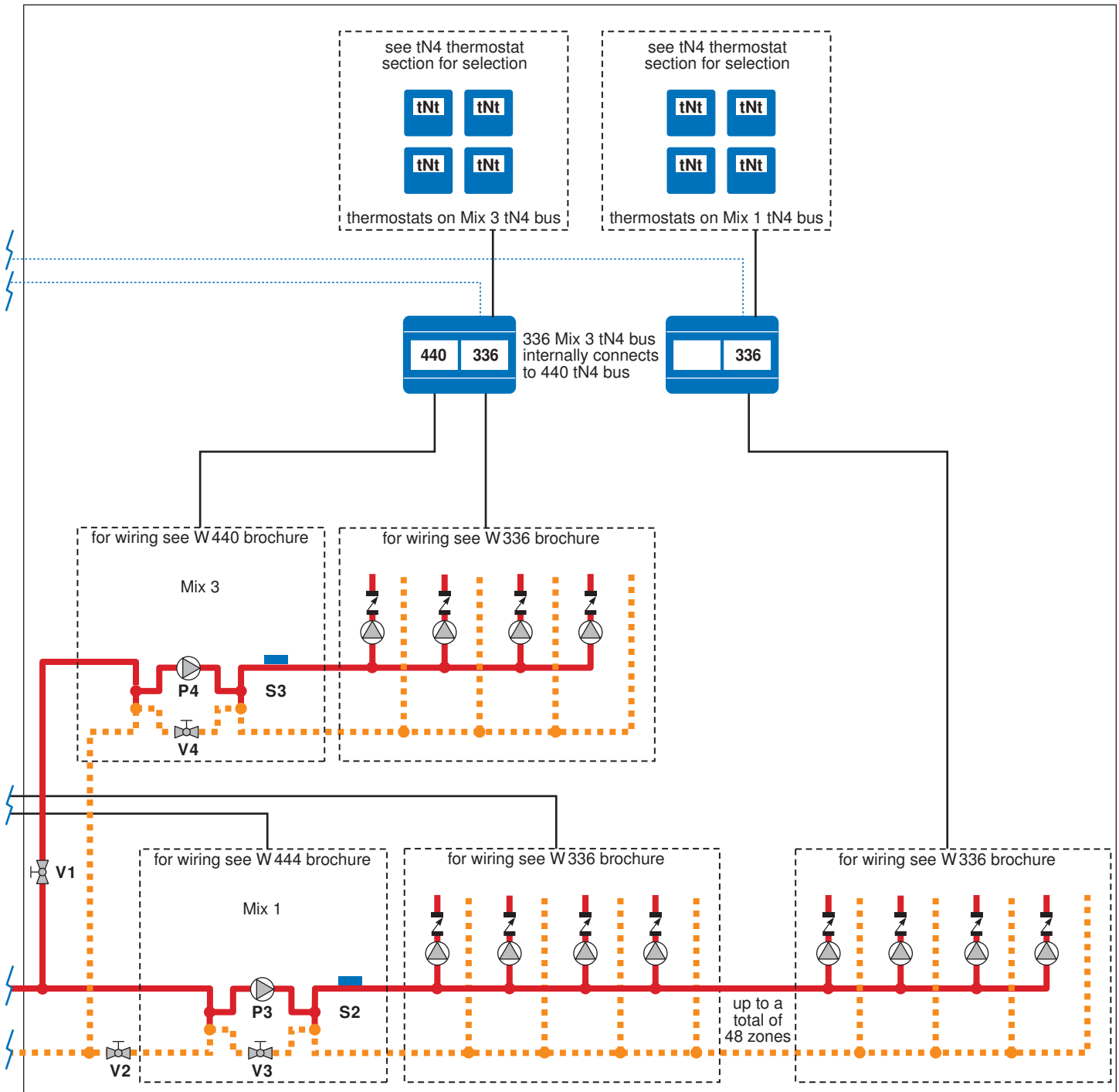

## Application A 423-4

**System Description:** The Universal Reset Module 423 operates two on-off or modulating boilers to provide outdoor reset to the heating system and overrides the reset temperature to provide indirect domestic hot water tank heating. The 423 connects to 3 Mixing Expansion Modules to provide outdoor reset to mixing zones.

A Mixing Expansion Module 441 operates a 4-way mixing valve for the mix 1 heating system and connects to tekmarNet®4 Bus 1 on the 423. Six tekmarNet®4 Thermostats operate six mix 1 zone valves through a Zone Manager 335.

(Continued on next page)

**Concept Drawing:** This is only a concept drawing, not an engineered drawing. It is not intended to describe a complete system, nor any particular system. It is up to the system designer to determine the necessary components for and configuration of the particular system being designed, including additional equipment, isolation relays (for loads greater than the control's specified output ratings), and any safety devices which in the judgement of the designer are appropriate, in order to properly size, configure and design that system and to ensure compliance with building and safety code requirements.

### Legend:

- A1 = DHW Aquastat
- P1 = DHW Pump
- P2 = Primary Pump
- P3...P5 = Mix System Pump
- S1 = Boiler Supply Sensor 071
- S2...S4 = Mix Supply Sensor 071
- S5 = Outdoor Sensor 070
- V1...V3 = Balancing or Globe Valve
- V4...V6 = Pressure Differential Bypass Valve
- V7...V9 = Mixing Valve 720 to 724

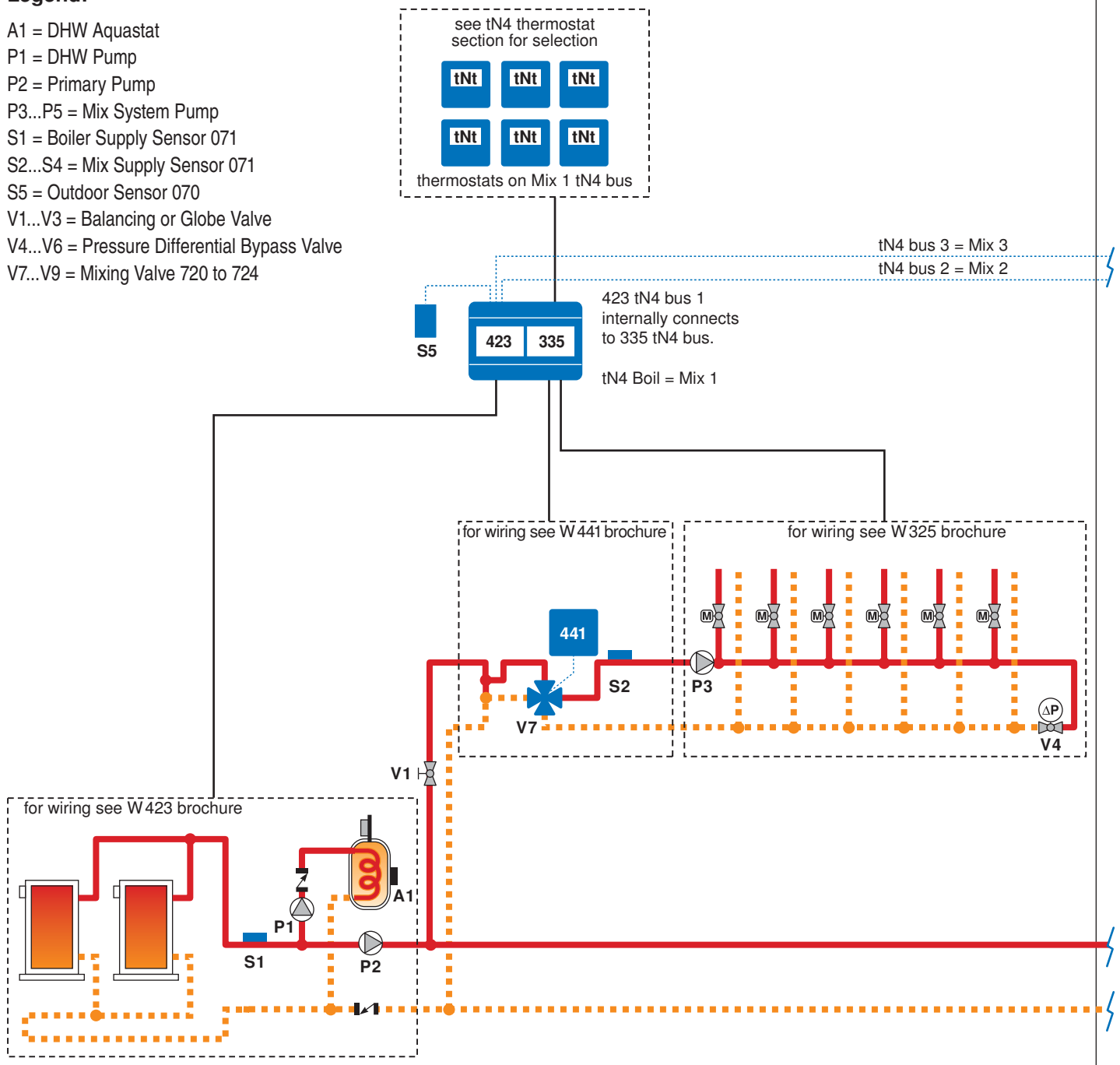

## Application A 423-4

A Mixing Expansion Module 441 operates a 4-way mixing valve for the mix 2 heating system and connects to tekmarNet<sup>®</sup>4 Bus 2 on the 423. Six tekmarNet<sup>®</sup>4 Thermostats operate six mix 2 zone valves through a Zone Manager 335.

A Mixing Expansion Module 441 operates a 4-way mixing valve for the mix 3 heating system and connects to tekmarNet<sup>®</sup>4 Bus 3 on the 423. Six tekmarNet<sup>®</sup>4 Thermostats operate six mix 3 zone valves through a Zone Manager 335.

**Concept Drawing:** This is only a concept drawing, not an engineered drawing. It is not intended to describe a complete system, nor any particular system. It is up to the system designer to determine the necessary components for and configuration of the particular system being designed, including additional equipment, isolation relays (for loads greater than the control's specified output ratings), and any safety devices which in the judgement of the designer are appropriate, in order to properly size, configure and design that system and to ensure compliance with building and safety code requirements.

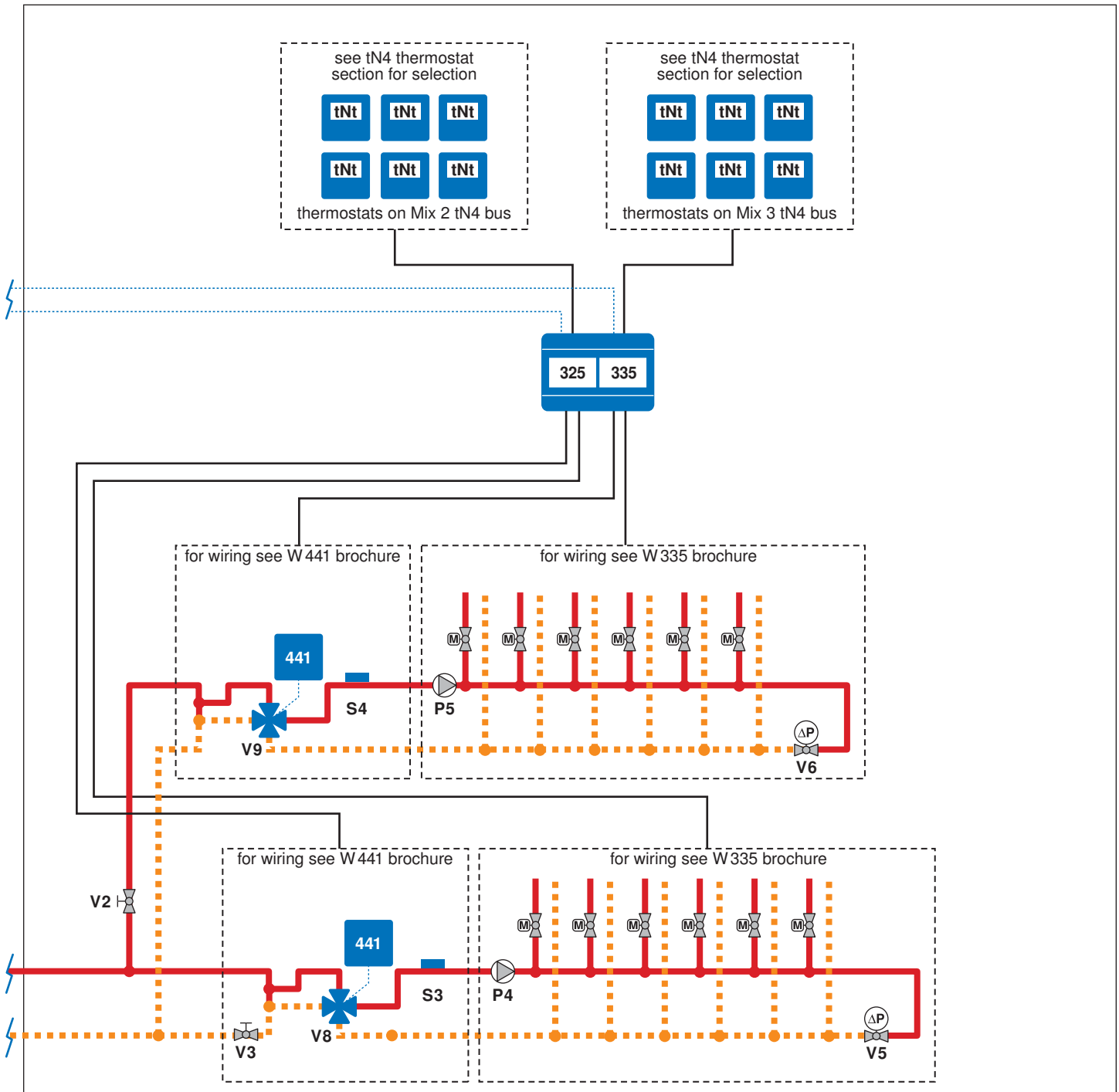

## Application A 542-1

**System Description:** The tekmarNet®4 Thermostat 541 or 542 operates a single heating zone. In hydronic heating systems, the 541 or 542 can connect to a Zone Manager, which provides power and a tekmarNet®4 bus connection. In non-hydronic applications, the 541 or 542 can be directly connected to the heating equipment. The 541 provides a single auxiliary sensor input, while the 542 provides two auxiliary sensor inputs. The auxiliary sensors allows the connection of an optional floor sensor, indoor sensor or outdoor sensor.

**Concept Drawing:** This is only a concept drawing, not an engineered drawing. It is not intended to describe a complete system, nor any particular system. It is up to the system designer to determine the necessary components for and configuration of the particular system being designed, including additional equipment, isolation relays (for loads greater than the control's specified output ratings), and any safety devices which in the judgement of the designer are appropriate, in order to properly size, configure and design that system and to ensure compliance with building and safety code requirements.

### Legend:

S1 = Slab Sensor 079

Z1 = Zone Valve

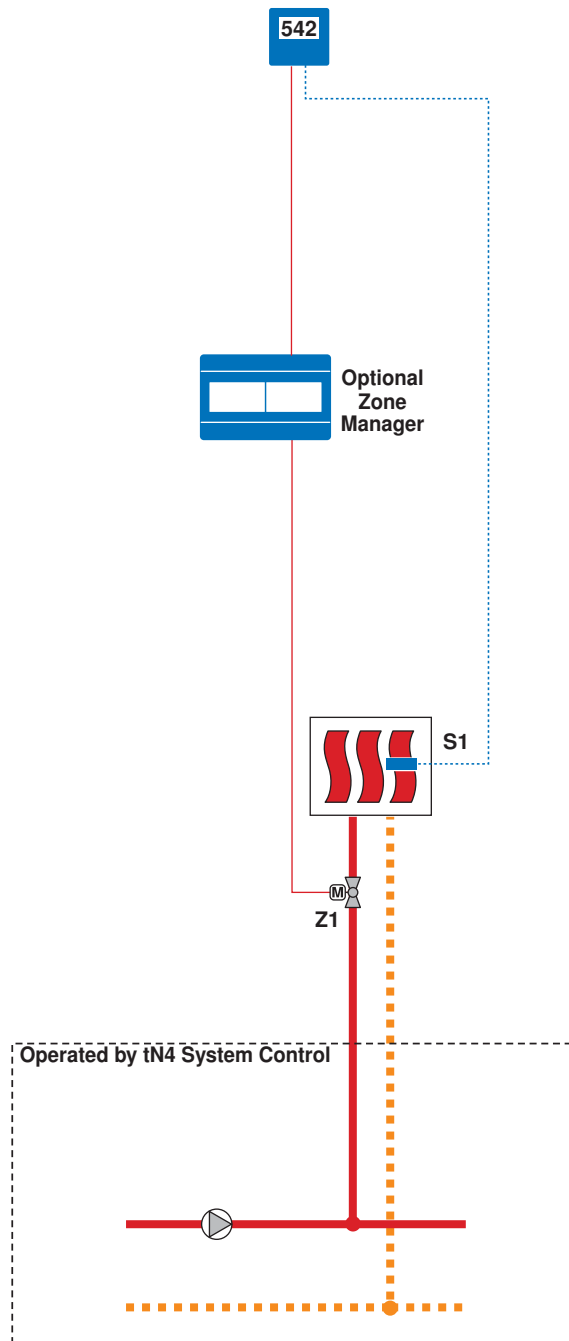

## Application A 543-1

**System Description:** The tekmarNet®4 Thermostat 543 operates two heating stages for a single zone. The two heating stages can both be hydronic, or can be mixture of hydronic and non-hydronic. In hydronic heating systems, the first heat stage and the tekmarNet®4 bus can connect to a Zone Manager, while the second heat stage can connect to the same or different Zone Manager. In non-hydronic heating systems, the first heat stage or second heat stage contact can directly connect to the heating equipment. The 543 provides two auxiliary sensor inputs to allow the connection of an optional floor sensor, indoor sensor or outdoor sensor.

**Concept Drawing:** This is only a concept drawing, not an engineered drawing. It is not intended to describe a complete system, nor any particular system. It is up to the system designer to determine the necessary components for and configuration of the particular system being designed, including additional equipment, isolation relays (for loads greater than the control's specified output ratings), and any safety devices which in the judgement of the designer are appropriate, in order to properly size, configure and design that system and to ensure compliance with building and safety code requirements.

### Legend:

S1 = Slab Sensor 079  
Z1 = Zone Valve  
Z2 = Zone Pump

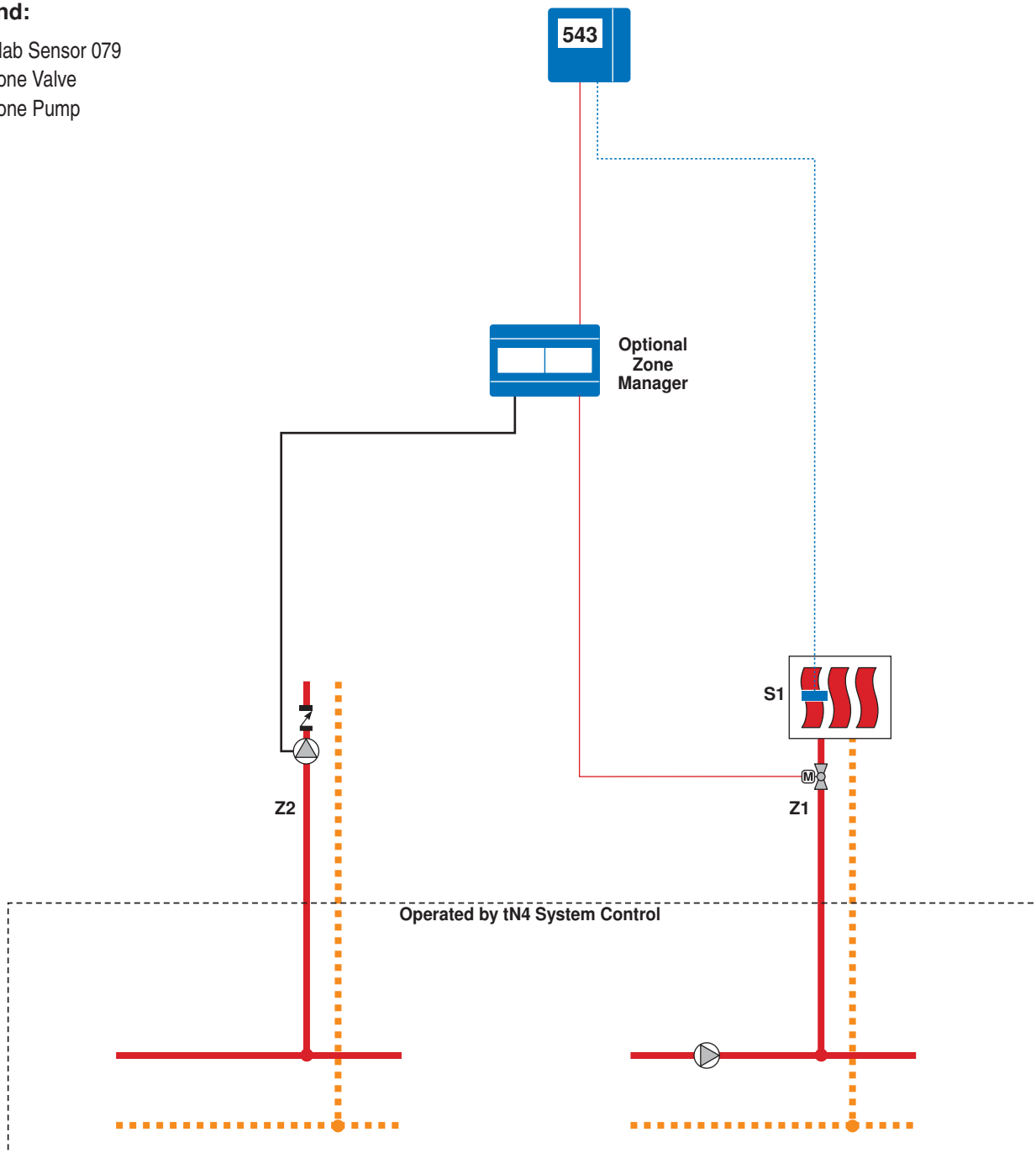

## Application A 544-1

**System Description:** The tekmarNet®4 Thermostat 544 operates a single heating zone, a single cooling system, and a single fan. In hydronic heating systems, the 544 can connect to a Zone Manager, which provides power and a tekmarNet®4 bus connection. In non-hydronic applications, the 544 can be directly connected to the heating equipment. The 544 can connect directly to the cooling and the fan equipment. The 544 provides two auxiliary sensor inputs to allow the connection of an optional floor sensor, indoor sensor or outdoor sensor.

**Concept Drawing:** This is only a concept drawing, not an engineered drawing. It is not intended to describe a complete system, nor any particular system. It is up to the system designer to determine the necessary components for and configuration of the particular system being designed, including additional equipment, isolation relays (for loads greater than the control's specified output ratings), and any safety devices which in the judgement of the designer are appropriate, in order to properly size, configure and design that system and to ensure compliance with building and safety code requirements.

### Legend:

C1 = Cooling System  
F1 = Fan  
S1 = Duct Sensor 083  
S2 = Slab Sensor 079  
Z1 = Zone Valve

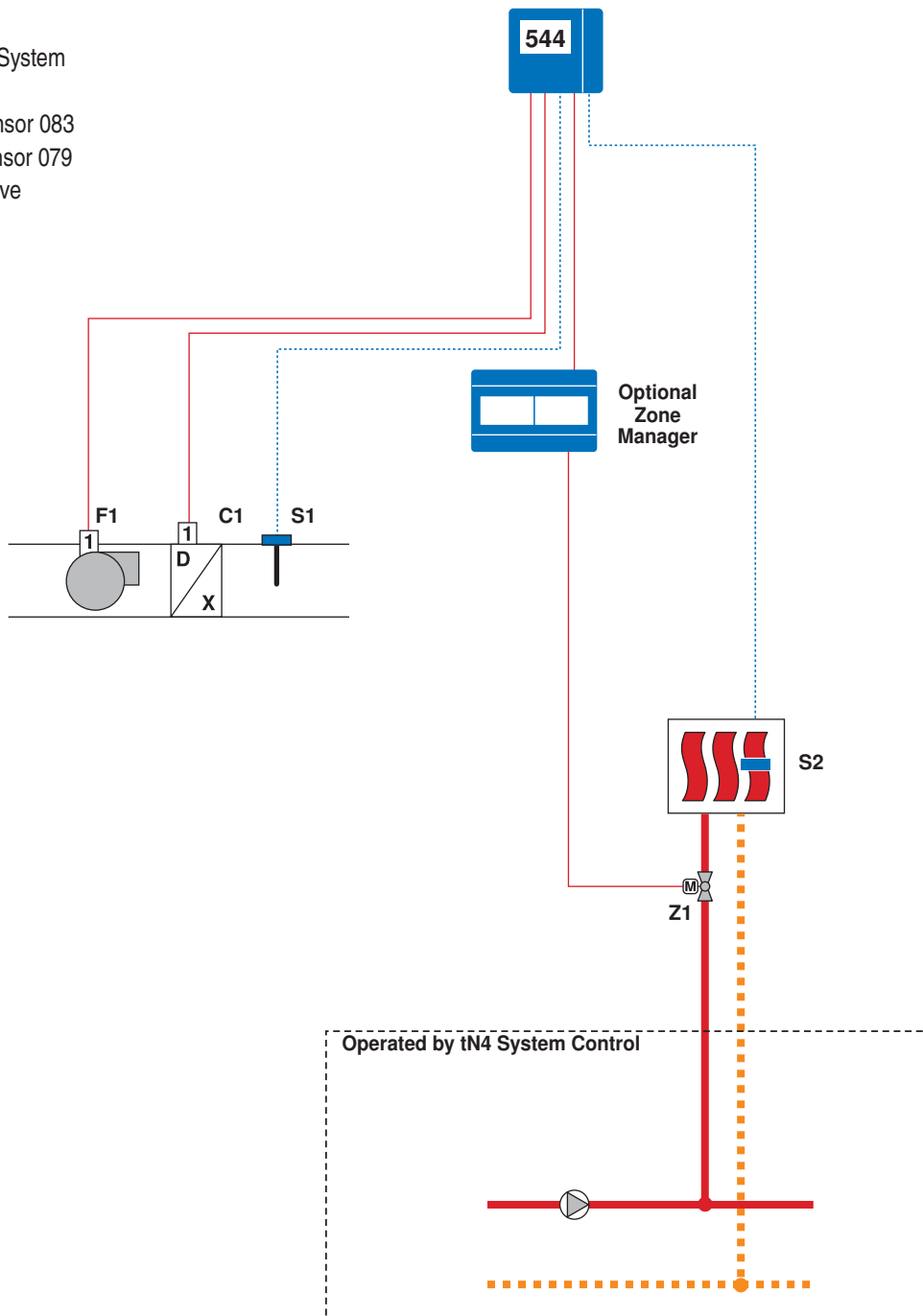

## Application A 545-1

**System Description:** The tekmarNet®4 Thermostat 545 operates two hydronic heating stages, a single cooling system, and a single fan. The first heat stage and tekmarNet®4 bus can connect to a Zone Manager. The second heat stage can connect to the same or different Zone Manager. The 545 directly connects to the cooling and fan equipment. The 545 can be assigned as a cooling group master and operate the cooling system on behalf of a group of tekmarNet®4 Thermostats assigned as members of the cooling group. The 545 provides two auxiliary sensor inputs to allow the connection of an optional floor sensor, indoor sensor, outdoor sensor, coil sensor, or duct sensor. The optional duct sensor can be used to provide freeze protection of the cooling coil.

**Concept Drawing:** This is only a concept drawing, not an engineered drawing. It is not intended to describe a complete system, nor any particular system. It is up to the system designer to determine the necessary components for and configuration of the particular system being designed, including additional equipment, isolation relays (for loads greater than the control's specified output ratings), and any safety devices which in the judgement of the designer are appropriate, in order to properly size, configure and design that system and to ensure compliance with building and safety code requirements.

### Legend:

- C1 = Cooling System
- F1 = Fan
- S1 = Duct Sensor 083
- S2 = Slab Sensor 079
- Z1 = Zone Valve
- Z2 = Zone Pump

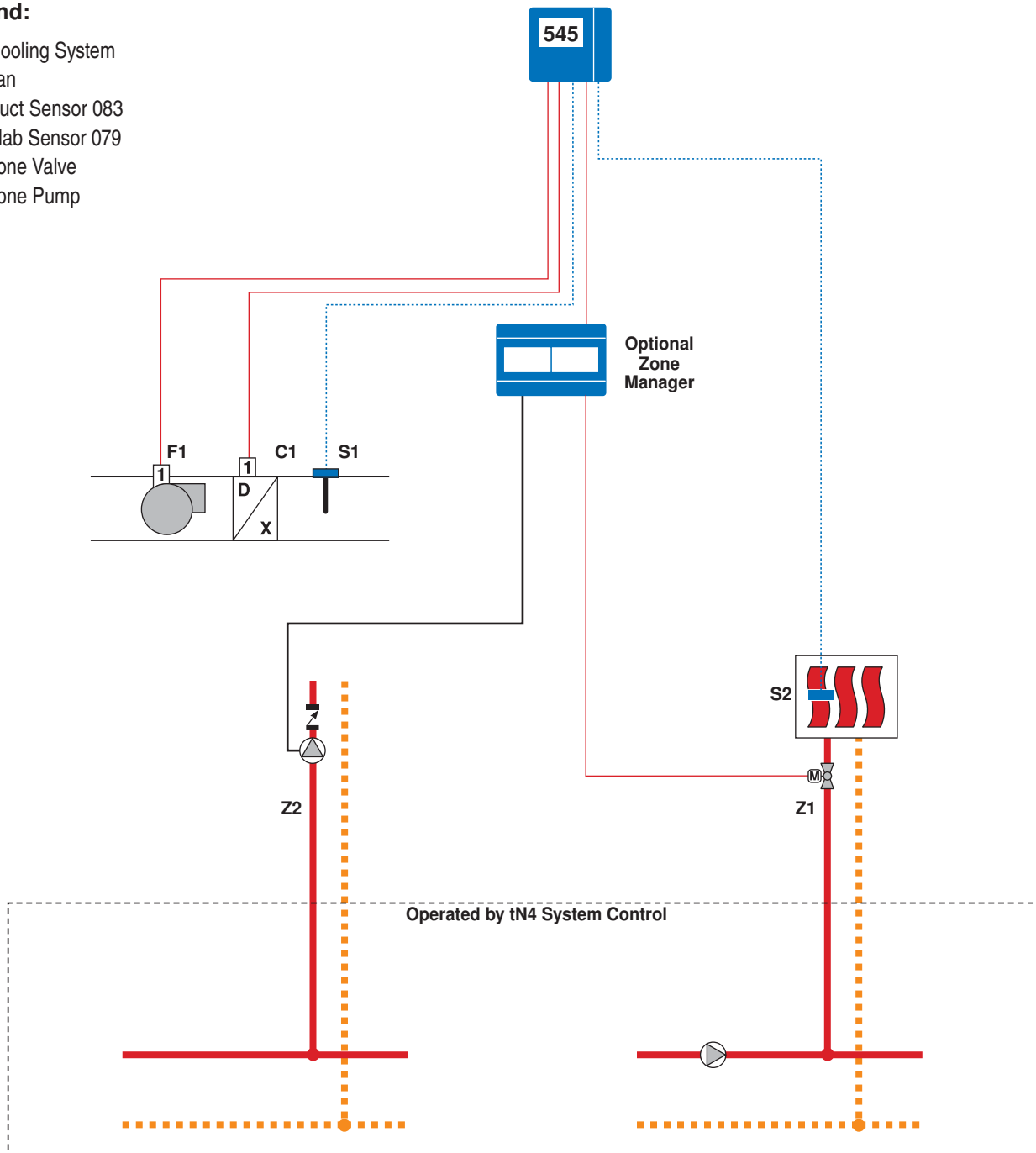

## Application A 545-2

**System Description:** The tekmarNet®4 Thermostat 545 operates two heating stages, a single cooling system, and a single fan. The first heat stage is hydronic and can connect to a Zone Manager together with the tekmarNet®4 bus. The second heat stage connects to a forced air heating system. The 545 directly connects to the cooling and fan equipment. The 545 can be assigned as a cooling group master and operate the cooling system on behalf of a group of tekmarNet®4 Thermostats assigned as members of the cooling group. The 545 provides two auxiliary sensor inputs to allow the connection of an optional floor sensor, indoor sensor, outdoor sensor, coil sensor, or duct sensor. The optional duct sensor can be used to provide freeze protection of the heating and cooling coil.

**Concept Drawing:** This is only a concept drawing, not an engineered drawing. It is not intended to describe a complete system, nor any particular system. It is up to the system designer to determine the necessary components for and configuration of the particular system being designed, including additional equipment, isolation relays (for loads greater than the control's specified output ratings), and any safety devices which in the judgement of the designer are appropriate, in order to properly size, configure and design that system and to ensure compliance with building and safety code requirements.

### Legend:

- C1 = Cooling System
- F1 = Fan
- H2 = Forced Air Heating System
- S1 = Duct Sensor 083
- S2 = Slab Sensor 079
- Z1 = Zone Valve

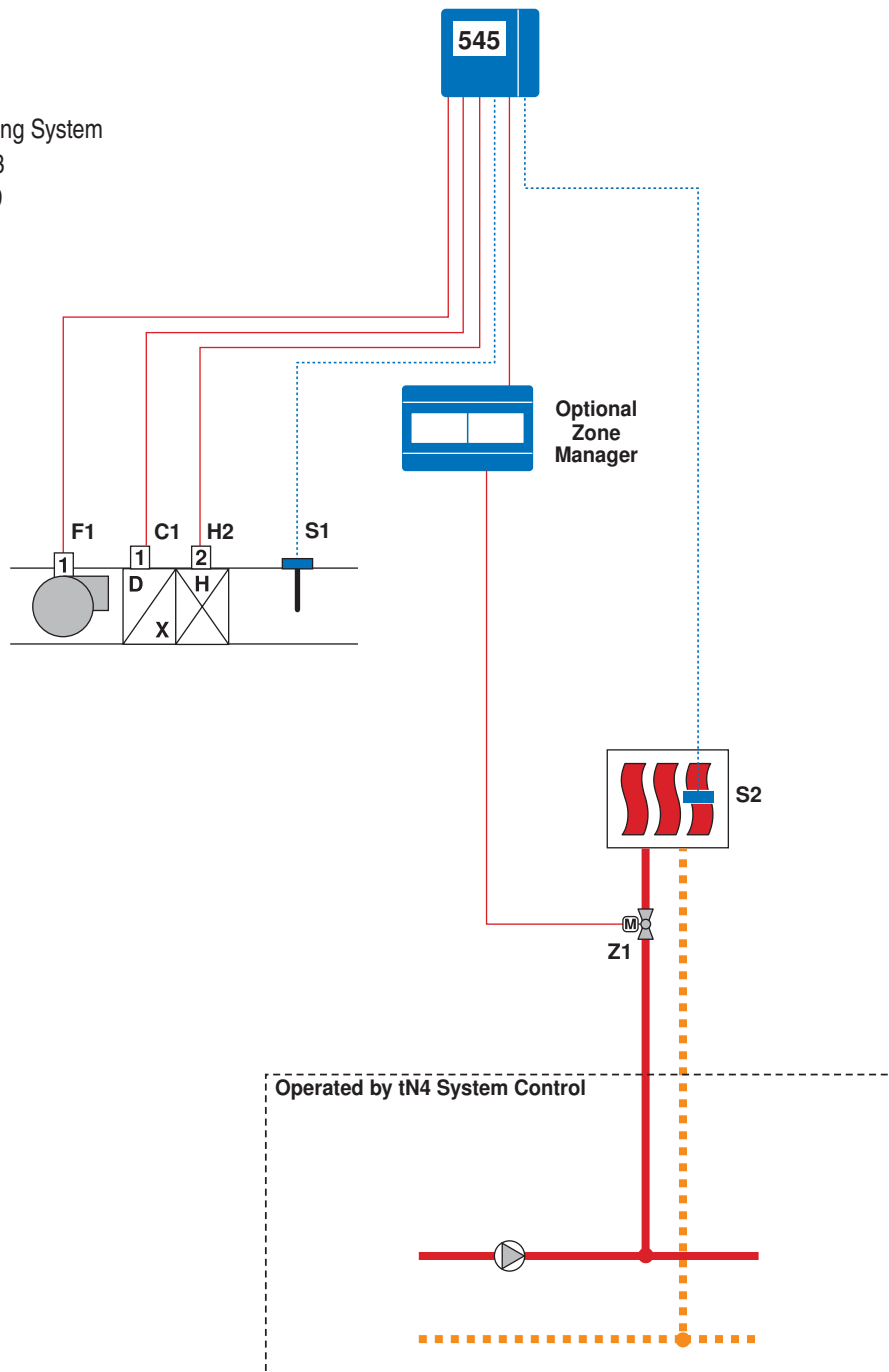

## Application A 546-1

**System Description:** The tekmarNet<sup>®</sup>4 Thermostat 546 operates two heating stages, a two stage cooling system, a fan, and a heat recovery ventilation unit. The first stage is hydronic heating, and can connect to a Zone Manager with the tekmarNet<sup>®</sup>4 bus. The second stage is forced air heating and connects directly with the forced air heating system. The 546 directly connects to the cooling and fan equipment. The 546 can be assigned as a cooling group master and operate the cooling system on behalf of a group of tekmarNet<sup>®</sup>4 Thermostats assigned as members of the cooling group. The 546 operates the main fan when the second stage heat or cooling systems are operating. The 546 operates a heat recovery ventilation unit fan and operates the main fan at the same time due to the primary-secondary ducting. The 546 provides three auxiliary sensor inputs to allow the connection of an optional floor sensor, indoor sensor, outdoor sensor, coil sensor, or duct sensor. The optional duct sensor can be used to provide freeze protection of the heating and cooling coil.

**Concept Drawing:** This is only a concept drawing, not an engineered drawing. It is not intended to describe a complete system, nor any particular system. It is up to the system designer to determine the necessary components for and configuration of the particular system being designed, including additional equipment, isolation relays (for loads greater than the control's specified output ratings), and any safety devices which in the judgement of the designer are appropriate, in order to properly size, configure and design that system and to ensure compliance with building and safety code requirements.

### Legend:

- C1 = Two-Stage Cooling System
- F1 = Fan
- F2 = HRV / ERV Fan
- H2 = Forced Air Heating System
- S1 = Outdoor Sensor 070
- S2 = Slab Sensor 079
- S3 = Duct Sensor 083
- Z1 = Zone Valve

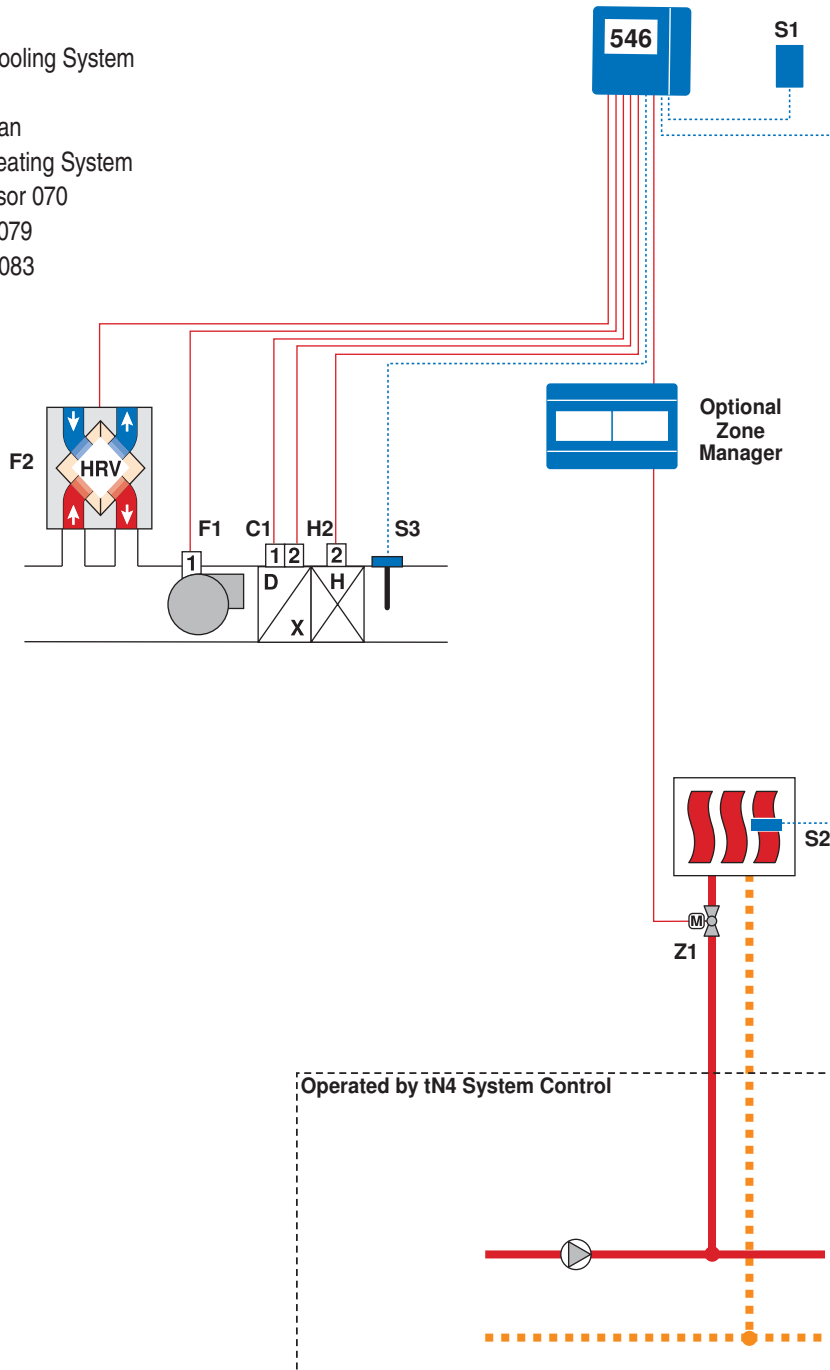



## Application A 546-3

**System Description:** The tekmarNet<sup>®</sup>4 Thermostat 546 operates two heating stages, a two stage cooling system, and a two stage fan. The first stage is hydronic heating, and can connect to a Zone Manager together with the tekmarNet<sup>®</sup>4 bus. The second stage is hydronic heating and can connect to the same or different Zone Manager. The 546 directly connects to the cooling and fan equipment. The 546 can be assigned as a cooling group master and operate the cooling system on behalf of a group of tekmarNet<sup>®</sup>4 Thermostats assigned as members of the cooling group. The 546 operates the main fan at the same time the cooling system is operating. The fan operates at low speed for the first stage of cooling and at high speed for the second stage of cooling. Ventilation is provided by operating the fan at low speed after the cooling has shut off. The 546 provides three auxiliary sensor inputs to allow the connection of an optional floor sensor, indoor sensor, outdoor sensor, coil sensor, or duct sensor. The optional duct sensor can be used to provide freeze protection of the cooling coil.

**Concept Drawing:** This is only a concept drawing, not an engineered drawing. It is not intended to describe a complete system, nor any particular system. It is up to the system designer to determine the necessary components for and configuration of the particular system being designed, including additional equipment, isolation relays (for loads greater than the control's specified output ratings), and any safety devices which in the judgement of the designer are appropriate, in order to properly size, configure and design that system and to ensure compliance with building and safety code requirements.

### Legend:

- C1 = Two-Stage Cooling
- F1 = Two-Stage Fan
- S1 = Outdoor Sensor 070
- S2 = Slab Sensor 079
- S3 = Duct Sensor 083
- Z1 = Zone Valve
- Z2 = Zone Pump

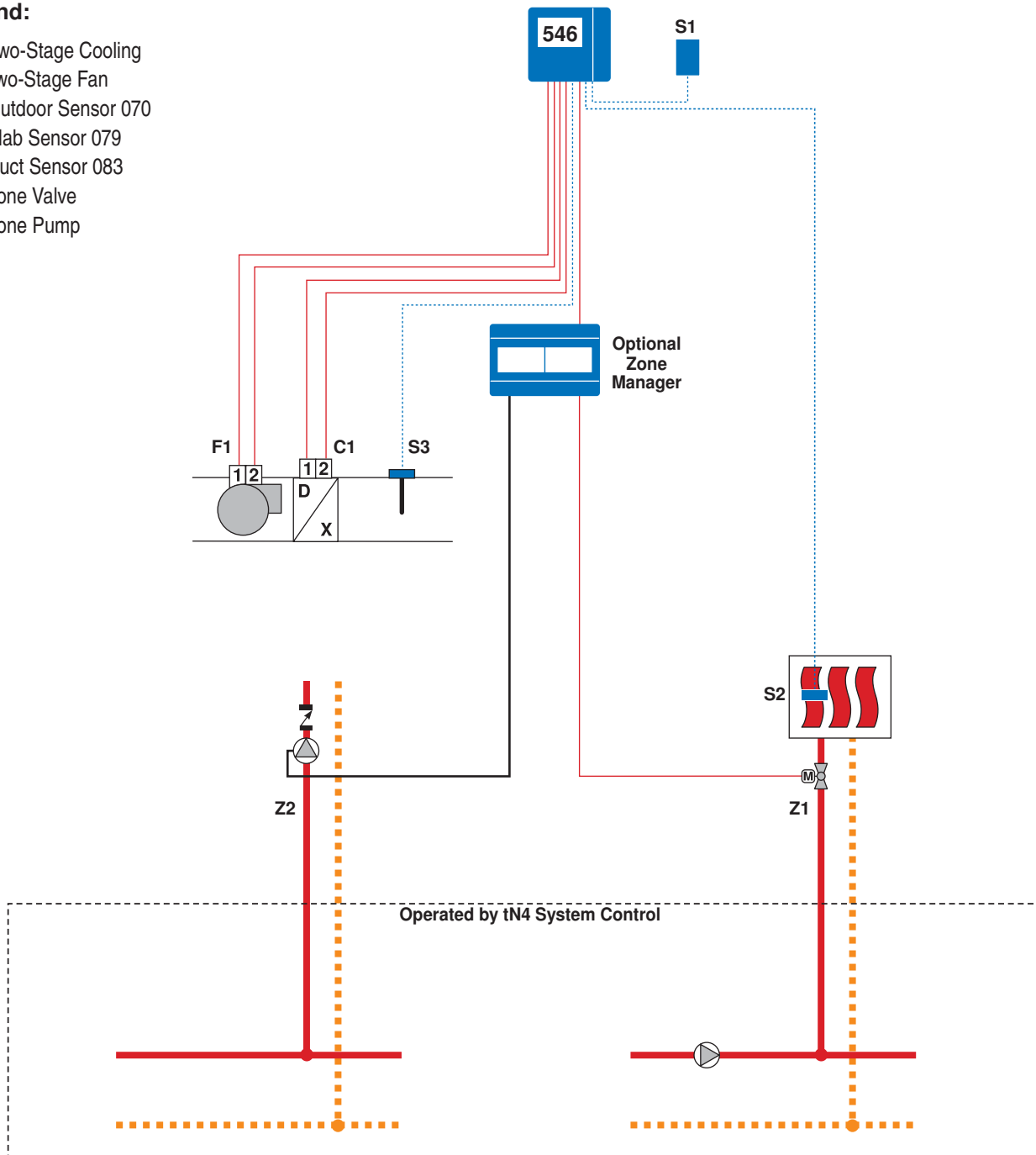



tekmar Control Systems Ltd., Canada  
tekmar Control Systems, Inc., U.S.A.  
**Head Office: 5100 Silver Star Road**  
**Vernon, B.C. Canada V1B 3K4**  
**(250) 545-7749 Fax. (250) 545-0650**  
**Web Site: [www.tekmarcontrols.com](http://www.tekmarcontrols.com)**