

Engineering Specification

Job Name _____

Contractor _____

Job Location _____

Approval _____

Engineer _____

Contractor's P.O. No. _____

Approval _____

Representative _____

Large Duplex Smart Strainers

Model: 691MF SM, Class 125
692MF SM, Class 150

Sizes: 8" – 16" (200 – 400 mm)

The 691MF SM and 692MF SM duplex basket smart strainers provide economical protection for costly pumps, meters, valves, and similar mechanical equipment by straining foreign matter from the piping system. Duplex strainers enable system maintenance to be performed without disrupting the flow. Smart and Connected technology comes standard on the 691MF SM and 692MF SM duplex strainers with two pre-installed pressure sensors at the inlet and outlet of the strainer. These sensors monitor the pressure drop that occurs over time when a strainer screen becomes clogged by foreign particles. When the differential pressure across the strainer screen exceeds the pre-configured threshold, an alert is triggered to the customer informing that action is required.

NOTICE

An add-on Sensor Control Monitor & Connection Kit is required to activate the pressure monitoring capability and collect data from the sensors. Without the connection kit, the sensors are passive components that do not communicate with any other device. The add-on connection kit communicates over wired RS-485 MODBUS or wi-fi connection via Nexa and is compatible with most Building Management and Building Automation Systems.

Features

- One gear operator actuates both diverter valves.
- Gear mechanism is enclosed, protecting it from corrosion.
- Shaft and internals are made of Stainless Steel.
- Discs and seats are available in Stainless Steel or Bronze.
- All internal parts are field replaceable.

NOTICE

The information contained herein is not intended to replace the full product installation and safety information available or the experience of a trained product installer. You are required to thoroughly read all installation instructions and product safety information before beginning the installation of this product.

Mueller Steam Specialty product specifications in U.S. customary units and metric are approximate and are provided for reference only. For precise measurements, please contact Mueller Steam Specialty Technical Service. Mueller Steam Specialty reserves the right to change or modify product design, construction, specifications, or materials without prior notice and without incurring any obligation to make such changes and modifications on Mueller Steam Specialty products previously or subsequently sold.



Model 691MF SM

Call customer service if you need assistance with technical details.

PRESSURE/TEMPERATURE–NON-SHOCK (WITH BOLTED COVERS)

691MFA SM	
8"-12" CWP	14"-16" CWP
200 psi @ 150°F	150 psi @ 150°F
(14 bar @ 66°C)	(10 bar @ 66°C)
176 psi @ 248°F	125 psi @ 248°F
(12 bar @ 120°C)	(9 bar @ 120°C)
692MFB SM	
8"-12" CWP	14"-16" CWP
232 psi @ 100°F	150 psi @ 150°F
(16 bar @ 38°C)	(10 bar @ 66°C)
221 psi @ 248°F	125 psi @ 248°F
(15 bar @ 120°C)	(9 bar @ 120°C)
692MFD SM	
8"-12" CWP	14"-16" CWP
232 psi @ 100°F	150 psi @ 150°F
(16 bar @ 38°C)	(10 bar @ 66°C)
232 psi @ 248°F	125 psi @ 248°F
(16 bar @ 120°C)	(9 bar @ 120°C)
692MFH SM	
8"-12" CWP	14"-16" CWP
232 psi @ 100°F	150 psi @ 150°F
(16 bar @ 38°C)	(10 bar @ 66°C)
225 psi @ 248°F	125 psi @ 248°F
(16 bar @ 120°C)	9 bar @ 120°C)

Note:

Maximum temperature can be limited by gasket and seat material. Consult factory. Clamped covers available but limited to 150 psi @ 150°F for all sizes.

Mueller Steam Specialty™

A WATTS Brand

Available Features with Sensor Control Monitor Installed

- Real-time pressure monitoring
- Visual Display – Pressure and temperature data for each sensor, Screen Pressure differential, Screen fill percentage
- Data streaming via MODBUS RS-485 Serial Communication [BAS] or Nexa Cloud Communication [Wi-Fi]
- Local alerts on fill exceeding threshold [LCD UI/UX and Dry Contact Closures]

Alerts

- Display
- OLED Display
- BMS Alarm
- RS-485 MODBUS or Nexa Cloud via Wi-Fi



Baskets

- Gasketed and seated to prevent particle bypass around the basket.
- Large Open Area Ratios to ensure minimum pressure drop across the unit.

Refer to the Technical Data section of the Mueller Steam Specialty Engineering binder.

Screens

MODEL	SIZE	STANDARD (WATER)	
	IN.	MATERIAL	OPENING
691MFA SM 692MFB SM 692MFD SM 692MFH SM	8 – 16	304SS	0.125 perf

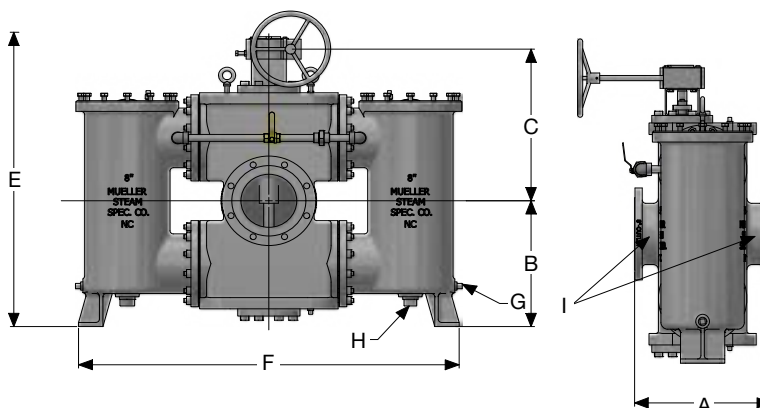

Models 691MF SM, 692MF SM

Dimensions and Weights

SIZE		DIMENSIONS						WEIGHT		Cv VALUE	PRESSURE SENSOR PORT								
		A	B	C		E SCREEN REMOVAL		F	G (NPT)		H (NPT)			I (NPT)					
in.	mm	in.	mm	in.	mm	in.	mm	in.	mm	in.	mm	lb	kg	in.					
8	200	20	508	19	483	24 9/16	623	62	1575	54 3/4	1391	1	25	2	50	1365	620	650	1/2
10	250	24	610	20 1/2	521	28 3/4	730	72 1/2	1842	61	1549	1	25	2	50	1970	894	960	1/2
12	300	30	762	25 1/2	648	30 3/4	781	87 1/2	2223	65 7/8	1673	1	25	2	50	2800	1272	1450	1/2
14	350	32	813	27 7/8	708	30 1/8	765	95 1/2	2426	71	1803	1	25	2	50	3300	1500	2000	1/2
16	400	36 3/4	933	32	813	34 3/4	883	80 1/2	2045	80 1/2	2045	1 1/2	40	2	50	4400	2000	2500	1/2

Note: Apply for Certified Drawings.
Handwheel dimension is 18".

Typical Service

- Duplex Strainers are designed for use in fluid handling systems where the flow cannot be shut down for basket cleaning.
- Typical services include cooling water, compressors, condensers, fire lines, fuel lines, lubrication systems, salt and fresh water systems, chemical process systems, and pump suction service.
- Consider strainer body and screen material as well as gasket and seat materials for suitability in particular service.

Construction

- All body parts are heavy castings.
- Covers are bolted, clamped covers are available (limited to 150 psi, 100°F).

Materials

ITEM	691MFA SM	692MFB SM	692MFD SM	692MFH SM
Body	Cast Iron ASTM A126 B	Aluminum Bronze ASTM B148	Carbon Steel ASTM A216 WCB	Stainless Steel ASTM A351 CF8M
Cover	Plate A516-70	Bronze Plate	Carbon Steel Plate 516-70	Stainless Steel Plate A240-316
Seat	Bronze	Bronze	Bronze	A351-CF8M
Shaft	316SS	316SS	316SS	316SS
O-ring Seal	Buna-N	Buna-N	Buna-N	Buna-N
Pressure Sensor	Mixed Composite	Mixed Composite	Mixed Composite	Mixed Composite
Disc	Monel, Bronze, or Stainless Steel			

Note: Stainless steel pickling and passivation are available upon request. Consult factory.

How to order Mueller Steam Specialty

Model 792MFD SM, 794MFD SM, 796MFD SM

Example 4.0 792MFDH SM

This is a 4" Class 150 flanged duplex basket smart strainer with a carbon steel body and 316SS ball.

4.0 792MFDH SM

Size: _____

Model: _____

- 791 - Class 125
- 792 - Class 150
- 794 - Class 300
- 796 - Class 600
- 691 - Class 125 Large Diameter
- 692 - Class 150 Large Diameter

Connection: _____

- S - Screwed, Sizes ¾" – 1½"
- F - Flanged, Sizes ¾" – 1½"
- MF - Flanged, Sizes 2" – 16"

Body: _____

- A - Cast Iron
- B - Bronze
- D - Carbon Steel
- H - Stainless Steel

Ball/Disc: _____

- Q - Monel
- B - Bronze
- H - Stainless Steel

Option: _____

- SM - Smart & Connected (includes pressure sensors, Sensor Control Monitor **sold separately**).



A WATTS Brand

USA: T: (800) 334-6259 • MuellerSteam.com
Latin America: T: (52) 55-4122-0138 • MuellerSteam.com

