

**Model: 722G**

Job Name \_\_\_\_\_

Contractor \_\_\_\_\_

Job Location \_\_\_\_\_

Approval \_\_\_\_\_

Engineer \_\_\_\_\_

Contractor's P.O. No. \_\_\_\_\_

Approval \_\_\_\_\_

Representative \_\_\_\_\_

**LEAD FREE\*****Ductile Iron  
LOCXEND®  
CONTROL CHEK® Valves****Models: 722G****Sizes: 2" – 12"**

PRESSURE/TEMPERATURE–NON-SHOCK		
MODEL	SIZES	CWP
722G	2"-12	640psi @ 100°F 565psi @ 300°F

Max. temp can be limited by gasket material. Consult factory.

**Typical Service**

The LOCXEND® CONTROL CHEK® valve is designed for installation in pump discharge grooved end piping systems where it performs triple duty. It acts as a spring loaded silent check valve, a shutoff valve, and a balancing valve. Used in conjunction with the Mueller Steam Specialty Suction Diffuser, it constitutes a compact and effective complete pump protection and isolation package.

**Operation**

- Disc is spring loaded to close the valve prior to flow reversal, protecting the pump and guarding against water hammer.
- Disc opens at .25psi
- Disc opens 1/3" for each inch of line size, allowing greater flow than similar products
- Disc is fully guided with external threaded stem.
- Threaded stem allows flow adjustment from bubble tight shut-off to full flow.

**Features**

- Position indicator ensures accurate and repeatable balancing through disc positioning in throttling service.
- Stem and yoke are external unwetted parts so are not subject to corrosion or erosion by line fluids. This is a design feature unique to the Mueller Steam Specialty CONTROL CHEK®.
- Field servicing is easy and requires no special tools.
- NPT drain plug at location "C" is standard. (See next page.)
- Gauge taps are available at both inlet and outlet ends.

Mueller Steam Specialty product specifications in U.S. customary units and metric are approximate and are provided for reference only. For precise measurements, please contact Mueller Steam Specialty Technical Service. Mueller Steam Specialty reserves the right to change or modify product design, construction, specifications, or materials without prior notice and without incurring any obligation to make such changes and modifications on Mueller Steam Specialty products previously or subsequently sold.

**Model 722G****Materials**

	722G
Body and Yoke	Ductile Iron ASTM A395 (60-40-18) or A536
Disc	Aluminum Bronze ASTM B142, C950
Stem	316 S.S.
Seat-Guide	Bronze ASTM B584 (81-3-7-9)
Disc-Guide*	Cast Iron ASTM A126-B
Seat*	Bronze
Flanged Gland	Cast Iron ASTM A126-B
Packing	Compressed Fiber
Spring	302 Stainless Steel
Stem Guide	Ductile Iron ASTM A395 or A536
O-Rings	EPDM

\*Separate disc-guide and seat used on 6" and larger. Flanged Models 721 and 722 are available for Class 125 and Class 300 service.

**NOTICE**

The information contained herein is not intended to replace the full product installation and safety information available or the experience of a trained product installer. You are required to thoroughly read all installation instructions and product safety information before beginning the installation of this product.

**\*The wetted surface of this product contacted by consumable water contains less than 0.25% of lead by weight.**

**A WATTS Brand**

## Dimensions and Weights

SIZE		DIMENSIONS						WEIGHT	
		A		B		C (NPT)			
<i>in.</i>	<i>in.</i>	<i>mm</i>	<i>in.</i>	<i>mm</i>	<i>in.</i>	<i>mm</i>	<i>lbs.</i>	<i>kgs.</i>	
2	9 <sup>3</sup> / <sub>8</sub>	238	9 <sup>5</sup> / <sub>8</sub>	244	1/2	15	23	10	
2 1/2	10 1/4	260	9 5/8	244	1/2	15	24	11	
3	11 1/4	285	10 1/8	257	1/2	15	33	15	
4	15 5/8	397	12 5/8	321	1/2	15	84	38	
6	19 5/8	492	17 1/2	445	3/4	20	156	70	
8	23 5/8	600	18	457	3/4	20	300	136	
10	28	711	21 3/4	552	1	25	392	178	
12	31 5/8	803	25	635	1	25	496	225	

Apply for Certified Drawings.

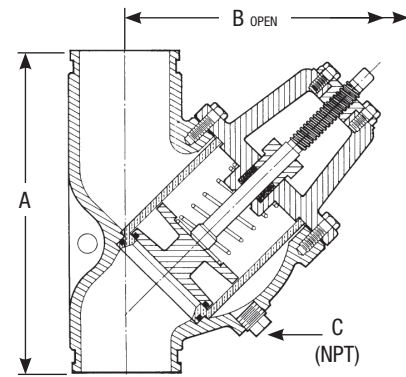

Model 722G

**Limited Warranty:** Mueller Steam Specialty warrants each product to be free from defects in material and workmanship under normal usage for a period of one year from the date of original shipment. In the event of such defects within the warranty period, the Company will, at its option, replace or recondition the product without charge. This shall constitute the sole and exclusive remedy for breach of warranty, and the Company shall not be responsible for any incidental, special or consequential damages, including without limitation, lost profits or the cost of repairing or replacing other property which is damaged if this product does not work properly, other costs resulting from labor charges, delays, vandalism, negligence, fouling caused by foreign material, damage from adverse water conditions, chemical, or any other circumstances over which the Company has no control. This warranty shall be invalidated by any abuse, misuse, misapplication or improper installation of the product. **THIS WARRANTY IS IN LIEU OF ALL OTHER WARRANTIES, EXPRESS OR IMPLIED, INCLUDING ANY IMPLIED WARRANTIES OF MERCHANTABILITY OR FITNESS FOR A PARTICULAR PURPOSE.** Any implied warranties that are imposed by law are limited in duration to one year.

Some States do not allow limitations on how long an implied warranty lasts, and some States do not allow the exclusion or limitation of incidental or consequential damages. Therefore the above limitations may not apply to you. This Limited Warranty gives you specific legal rights, and you may have other rights that vary from State to State. You should consult applicable state laws to determine your rights.



**A WATTS Brand**

USA: T: (800) 334-6259 • F: (800) 421-6772 • MuellerSteam.com

Latin America: T: (52) 81-1001-8600 • MuellerSteam.com

© 2019 Mueller Steam Specialty