

**Model: 758G**

Job Name \_\_\_\_\_

Contractor \_\_\_\_\_

Job Location \_\_\_\_\_

Approval \_\_\_\_\_

Engineer \_\_\_\_\_

Contractor's P.O. No. \_\_\_\_\_

Approval \_\_\_\_\_

Representative \_\_\_\_\_

**LEAD FREE\*****Cast Lead Free\*  
LOCXEND®  
Y Strainers****Model: 758G****Sizes: 2" - 12"**

Model 758G

**PRESSURE/TEMPERATURE–NON-SHOCK**

| MODEL | MATERIAL     | CWP                              |
|-------|--------------|----------------------------------|
| 758G  | Ductile Iron | 640psi @ 100°F<br>150psi @ 565°F |

Pressure/Temperature can be limited by gasket material. Consult factory.

**Typical Service**

- The LOCXEND® Y Strainer is designed for installation in grooved end piping systems.
- Used extensively to strain foreign matter from pipe lines and provide economical protection for costly pumps, meters, valves, and other similar mechanical equipment

**Features**

- Mueller "BREECH-LOK STRAINERS"
  - Furnished as standard in sizes 8" and larger.
  - A one-quarter turn securely locks the screen in its seat.
  - Allows for easy bolting of the cover flange.
- Tapered seats in both the body and cover flange retain screen and prevent particle bypass

**Construction**

- All covers have NPT blowoff outlet at Location C. See next page.
- Recessed seat in the cover assures accurate screen alignment.
- Bosses at the inlet and outlet flanges are provided for the gauge taps.

**Self-cleaning**

- Self-cleaning is accomplished by opening the plug or valve connected to the blowoff outlet
- Advise when strainers are to be mounted in vertical piping so we can rotate the cover to position the blowoff at the lowest point.

Mueller Steam Specialty product specifications in U.S. customary units and metric are approximate and are provided for reference only. For precise measurements, please contact Mueller Steam Specialty Technical Service. Mueller Steam Specialty reserves the right to change or modify product design, construction, specifications, or materials without prior notice and without incurring any obligation to make such changes and modifications on Mueller Steam Specialty products previously or subsequently sold.

**Blowoff Outlets**

- Outlets are NPT tapped
- Sizes of tapping specified on next page.
- Not normally furnished with plug. Plug available, specify with order

**Capacity**

- Generously proportioned bodies
- Open Area Ratio much greater than pipe size, ensuring low pressure drop

**Screens**

| MODEL | SIZES      | STANDARD (WATER) |           | STEAM RECOMENDATION |           |
|-------|------------|------------------|-----------|---------------------|-----------|
|       |            | MATERIAL         | OPENING   | MATERIAL            | OPENING   |
| 758G  | 2"–4"      | 304SS            | .062 perf | 304SS               | .045 perf |
| 758G  | 5"–8"      | 304SS            | .125 perf | 304SS               | .045 perf |
| 758G  | 10" and Up | 304SS            | .125 perf | 304SS               | .062 perf |

**NOTICE**

The information contained herein is not intended to replace the full product installation and safety information available or the experience of a trained product installer. You are required to thoroughly read all installation instructions and product safety information before beginning the installation of this product.

**\*The wetted surface of this product contacted by consumable water contains less than 0.25% of lead by weight.**

**A WATTS Brand**

## Materials

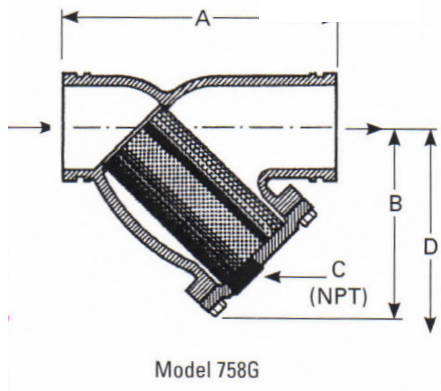

| BILL OF MATERIAL    |                              |
|---------------------|------------------------------|
| DESCRIPTION         | MATERIAL                     |
| BODY                | DUCTILE IRON SA 536 65-45-12 |
| COVER **            | DUCTILE IRON SA 536 65-45-12 |
| SCREEN              | 304 SS                       |
| GASKET              | Non-Asbestos                 |
| HEX HEAD CAP SCREWS | SAE J429 Gr. 5               |

\*\* Cover may be manufactured from equivalent grade plate material

## Pressure Drop

See Pressure Drop Charts in Technical Data Section of the Mueller Steam Specialty Engineering binder.

## Dimensions and Weights

| SIZE            | DIMENSIONS       |     |                  |     |                 |    | WEIGHT              |     | CV   |       |       |
|-----------------|------------------|-----|------------------|-----|-----------------|----|---------------------|-----|------|-------|-------|
|                 | A                |     | B                |     | C<br>(NPT)      |    | D<br>Screen Removal |     |      |       |       |
| in.             | in.              | mm  | in.              | mm  | in.             | mm | in.                 | mm  | lbs. | kgs.  | GPM   |
| 2               | 7 $\frac{7}{8}$  | 200 | 5 $\frac{1}{4}$  | 133 | $\frac{1}{2}$   | 13 | 7                   | 178 | 12   | 5.44  | 70    |
| 2 $\frac{1}{2}$ | 10               | 254 | 6 $\frac{1}{2}$  | 165 | 1               | 25 | 9 $\frac{3}{4}$     | 248 | 18   | 8.16  | 110   |
| 3               | 10 $\frac{1}{8}$ | 257 | 7                | 178 | 1               | 25 | 10                  | 254 | 23   | 10.4  | 140   |
| 4               | 12 $\frac{1}{8}$ | 308 | 8 $\frac{1}{4}$  | 210 | 1 $\frac{1}{2}$ | 38 | 12                  | 305 | 42   | 19    | 245   |
| 5               | 15 $\frac{5}{8}$ | 397 | 11 $\frac{1}{4}$ | 286 | 2               | 51 | 17                  | 432 | 80   | 36.3  | 400   |
| 6               | 18 $\frac{1}{2}$ | 470 | 13 $\frac{1}{2}$ | 343 | 2               | 51 | 20                  | 508 | 112  | 50.8  | 600   |
| 8               | 21 $\frac{5}{8}$ | 549 | 15 $\frac{1}{2}$ | 394 | 2               | 51 | 22 $\frac{3}{4}$    | 578 | 205  | 93    | 1,000 |
| 10              | 29 $\frac{1}{8}$ | 654 | 19 $\frac{1}{4}$ | 470 | 2               | 51 | 28                  | 711 | 277  | 125.6 | 1,580 |
| 12              | 33 $\frac{3}{4}$ | 762 | 22 $\frac{7}{8}$ | 552 | 2               | 51 | 30                  | 762 | 470  | 213.2 | 2,200 |

**Limited Warranty:** Mueller Steam Specialty warrants each product to be free from defects in material and workmanship under normal usage for a period of one year from the date of original shipment. In the event of such defects within the warranty period, the Company will, at its option, replace or recondition the product without charge. This shall constitute the sole and exclusive remedy for breach of warranty, and the Company shall not be responsible for any incidental, special or consequential damages, including without limitation, lost profits or the cost of repairing or replacing other property which is damaged if this product does not work properly, other costs resulting from labor charges, delays, vandalism, negligence, fouling caused by foreign material, damage from adverse water conditions, chemical, or any other circumstances over which the Company has no control. This warranty shall be invalidated by any abuse, misuse, misapplication or improper installation of the product. **THIS WARRANTY IS IN LIEU OF ALL OTHER WARRANTIES, EXPRESS OR IMPLIED, INCLUDING ANY IMPLIED WARRANTIES OF MERCHANTABILITY OR FITNESS FOR A PARTICULAR PURPOSE.** Any implied warranties that are imposed by law are limited in duration to one year.

Some States do not allow limitations on how long an implied warranty lasts, and some States do not allow the exclusion or limitation of incidental or consequential damages. Therefore the above limitations may not apply to you. This Limited Warranty gives you specific legal rights, and you may have other rights that vary from State to State. You should consult applicable state laws to determine your rights.



**A WATTS Brand**

USA: T: (800) 334-6259 • F: (800) 421-6772 • MuellerSteam.com

Latin America: T: (52) 81-1001-8600 • MuellerSteam.com

© 2019 Mueller Steam Specialty