

**DRT-100B & DRT-100B RESEARCH  
TURBIDIMETERS**

HF scientific, inc.  
3170 Metro Parkway  
Fort Myers, Florida 33916-7597  
Phone: (941) 337-2116  
Fax: (941) 332-7643



## FOREWORD

### HF TURBIDIMETERS

HF turbidimeters are manufactured to meet design criteria for nephelometers as described in Standard Methods For Examination of Water and Wastewater. HF turbidimeters are approved by the U.S. EPA\* as a means to measure the turbidity of potable water, waste water, and other liquids.

HF turbidimeters provide a linear display of turbidity, throughout all ranges, in Nephelometric Turbidity Units (NTU). HF turbidimeters use solid state electronic components because they resist thermal variation and are not affected by normal line voltage fluctuations.

HF turbidimeters can be calibrated using HF scientific factory certified Secondary Standards or Formazin. Factory calibration is accomplished using HF scientific Secondary Standards, which are factory certified traceable to Formazin, therefore, this instruction manual describes the proper procedures for calibration of HF turbidimeters using Secondary Standards.

HF turbidimeter manuals are designed to assist the user in taking full advantage of the instrument in a majority of its applications. However, in the event that unusual circumstances or problems, not covered by this manual, arise please feel free to contact our local distributor or the manufacturer.

HF scientific, inc.  
3170 Metro Parkway  
Fort Myers, Florida 33916-7597  
Phone: (941) 337-2116  
Fax: (941) 332-7643

Our engineering staff is available to help you with your specific needs.

*\*EPA approved means the instrument meets or exceeds the design and performance criteria as specified in the United States Environmental Protection Agency method 180.1.*



MODEL DRT-100B

IDENTIFICATION INFORMATION

The DRT-100B may be identified by its catalog number and description listed below:

<u>Instrument Catalog†No.</u>	<u>Description</u>
20012	Standard Model
20052	Research Model Includes additional features: Alarm Output; Recorder Output, 0-1 mA; Flow-thru unit; Control Output, 4-20 mA; High Range Attenuation



## OPERATING INSTRUCTIONS

### TABLE OF CONTENTS

I.	SPECIFICATIONS .....	1
II.	INSTALLATION .....	2
	A. Packing List of Contents .....	2
	B. Pre-installation Checkout .....	2
	C. Installation and Start-up .....	2
III.	MEASUREMENT PROCEDURES .....	3 - 5
	A. Adjustable Set Point Alarm Control - Standard Model PN #20012 .....	3
	B. Standardization .....	3 - 5
	C. Sample Measurement .....	5
IV.	CALIBRATION PROCEDURES .....	5 - 7
	A. Secondary Standard Set .....	5
	B. Standard Formazin Solutions .....	6
	C. Electronic Calibration .....	7
V.	FEATURES INCLUDED WITH THE RESEARCH MODEL (PN #20052) .....	8 - 9
	A. Adjustable Set Point Alarm Control .....	8
	B. Recorder Output, 0-1 mA .....	8
	C. Flow Through Unit for Continuous Measurement .....	8
	D. Attenuation Measurement .....	8
	E. Control Output, 4 - 20 mA .....	9
VI.	OPTIONAL FEATURE .....	9
VII.	SOURCE LAMP REPLACEMENT AND ALIGNMENT .....	10
VIII.	ACCESSORIES AND SUPPLIES .....	11
	WARRANTY .....	13





## I. SPECIFICATIONS

---

Ranges NTU	0 - 1 0 - 10 0 - 100 0 - 1000*
------------	---

---

Linearity	± 1% of full scale
Repeatability	± 1% of full scale
Sensitivity	.01 NTU

---

Power Consumption	45 Watts (Nominal) Fuse-0.5A (120V) Fuse-0.25A (240V)
-------------------	---

---

Supply Voltage	120VAC±10% 50/60Hz 240VAC±10% 50/60Hz
----------------	--

---

Controls	- Range Switch  - Reference Adjust  - Alarm Setting  - On/Off Switch  - 120V/240V Switch
----------	--

---

Dimensions	8"W x 10 1/2"L x 8 1/2"H
------------	--------------------------

---

Shipping Weight	12 pounds
-----------------	-----------

---

Operating temperature	0° - 50°C (32° - 122°F)
-----------------------	-------------------------

---

\*NOTE: On the maximum range of 0 - 1000 NTU the Digital Meter will read as high as 1,999. Readings over 1,000 may not be within published specifications for linearity.

## II. INSTALLATION

(A) <u>PACKING LIST OF CONTENTS</u>	<u>CAT #</u>	<u>QUANTITY</u>
Instruction Manual	50027	1
Reference Standard 0.02 NTU	60002	1
Accessory Case	21116	1
Lamp Alignment Tool	70820	1
Hex key Wrench 1/16"	20944	1
Spanner Wrench	50122	1
* Recorder and Control output, mating phone plug	70825	2
* Flow through unit	50071	1
Fuse 5 x 20 mm ½A quick acting (220-240 volt operation)	20955	1
Warranty Card (* Included with 20052)		

*A complete listing of spare parts is on page 11 of this Manual.*

### (B) PRE-INSTALLATION CHECKOUT

1. Extreme care should be taken when unpacking and handling the Reference Standard or sample cuvettes as surface scratches or finger smudges will cause measurement errors. Handle these items by the top only. (See Fig. 1)

### (C) INSTALLATION AND START-UP

1. The instrument is factory set for 120 volt operation. If 240 volt operation is desired, set the switch on the back of the instrument to "240", change fuse to ½A quick acting and provide appropriate power cord.
2. The Range Selector switch located on the front of the instrument should be in the 1000 range position.
3. Leave the Light Shield cap in place on the instrument when it is not in use in order to protect the sample well from dust, etc.
4. For best operation it is recommended that the instrument be left on continuously.

NOTE: A 240V fuse is provided in accessory kit.

### III. MEASUREMENT PROCEDURES

#### (A) ADJUSTABLE SET POINT ALARM CONTROL

This allows the user to set an alarm where a lamp will be illuminated if the NTU readings should become larger than the value set. The alarm point is set by placing the three position "ALARM" switch labeled "SET", "NORM", to the "SET" position. The potentiometer behind the face plate next to the "ALARM" switch is then adjusted until the digital display shows the desired value. The "ALARM" switch is then returned to "NORM". At anytime, the alarm limit currently set in the instrument may be determined by moving the "ALARM" switch to the "SET" position and reading the digital display. Placing the switch in the "OFF" position on PN #20012 will cause the unit to operate just as if the switch were placed in the "NORM" position.

#### (B) STANDARDIZATION

The Reference Standard supplied with this instrument is a pure liquid sealed in glass. It has a value of 0.02 NTU.

Extreme care should be taken to avoid surface scratches on the Reference Standard cuvette. Scratches, together with dust or film cause analysis error. The Reference Standard optical surface should be wiped clean each time it is to be used and it is important to use a lint free wiper such as "Kimwipes".

If cleanliness of the Reference Standard cuvette is in doubt, wash with detergent rinse several times and polish with "Kimwipes". Figure 1 shows the critical measuring area in all measuring containers.

The Reference Standard (Catalog No. 60002) should be replaced at least once per year.

The EPA recommends that cuvettes used for instrument calibration or sample measurement be indexed. For quick and repeatable indexing of the Reference Standard, an indexing ring and locator pin are included with this instrument.

When shipped, the white locator pin is installed in the collar ring around the optical well of your turbidimeter. The indexing ring is included in the accessory kit of this instrument.

To index your Reference Standard, slowly rotate the Reference Standard, at least one complete revolution, while observing the reading, and locate the position of the lowest reading. Without moving the Reference Standard, install the indexing ring over the ridged cap of the Reference Standard such that the notch on the ring aligns with the locator pin.

When standardizing this instrument in the future, simply insert the reference standard and rotate it until the notch on the indexing ring faces the locator pin. Standardize as per the following instructions. **(Please note that this reference standard is only indexed to the turbidimeter for which it was aligned.)**

Use the following procedure to standardize:

1. Place the Reference Standard in the Optical Well, indexed as described above.
2. Place the front panel Range Switch in the 1 NTU range.
3. Set the Reference Adjust knob, in the left forward corner instrument, such that the display reads .02 NTU.

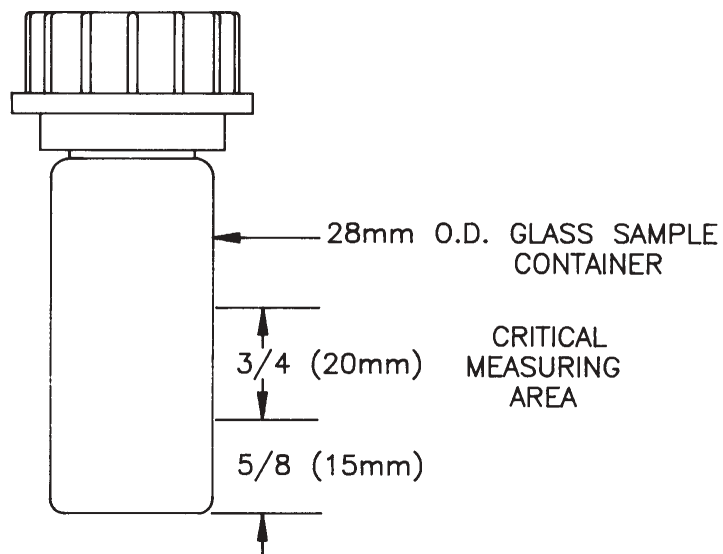

*Bottom*

The turbidimeter's optical system measures the liquid sample through this section of the Reference Standard, grab sample cuvette or Flow-Thru Vial. It is therefore important that this 3/4" wide band of the glass container be kept clean and free of scratches or abrasion.

FIGURE 1

(B) STANDARDIZATION (cont'd)

The instrument is now referenced to the factory calibration and unknown samples may be read directly in NTU. For best accuracy, the instrument should be standardized on a scheduled basis. The need to actually adjust standardization will vary depending upon the operational environment.

(C) SAMPLE MEASUREMENT

1. Place the sample in the Optical Well.
2. Set the Range Switch located on the front panel to an appropriate range.
3. Read the value on the digital display.

For accurate measurements in the low range rotate "grab samples" cuvettes in the well to obtain the minimum reading. Mark the cuvette and the instrument so that orientation of the cuvette will be identical each time it is placed in the instrument. Always use the cuvette cap when measuring a grab sample.

NOTE:

1. Settling particles or air in the sample may cause the digital reading to change rapidly. Readings should be taken without delay before turbid particles settle.
2. Cuvettes must be clean and free of smudges or scratches. Cleaning is accomplished by washing in a detergent solution then rinsing thoroughly 8 to 10 rinses in clean, preferably distilled, water to remove all streaks.

Scratched cuvettes should be replaced.

Reusable cuvettes, (pkg. of 10 each - catalog number 50052, pkg of 3 - catalog number 50051) should be stored in a clean, dust free environment.

IV. CALIBRATION PROCEDURES

(A) SECONDARY STANDARD SET (optional) Catalog No. 19887

HF Secondary Standards are recommended and certified by HF scientific. They are traceable to freshly prepared formazin primary standards. These standards are very easy to use off the shelf anytime without preparation making them an ideal turbidity standard. A Certified of Traceability is available on request to HF scientific Customer Service Department. HF Secondary Standards may be used for calibration of all HF turbidimeters. Order from HF scientific, inc.

**NOTE: Do not freeze standards. Do not leave standards in the measuring well for extended periods. Do not shake standards.**

Specific instructions for the usage of the certified Secondary Standard are included with the kit.

Each Secondary Standard Kit contains:

- Instructions
- 0.02 Reference Standard
- Certified Secondary Standard 8.00 and 800 NTU are contained in preselected cuvettes with light shield caps.
- A sturdy storage case.

(B) STANDARD FORMAZIN SOLUTIONS

Calibration of this instrument is based on Formazin, a material which can be made by synthesis and reproduced repeatedly within one percent. When properly mixed, it is uniform in the number, size and shape of its particles, thus making it an ideal turbidity standard. The unit of measure, and thus the calibration of this instrument is in Nephelometric Turbidity Units (NTU) based on Formazin.

Calibration samples may be obtained by diluting Formazin Stock Suspension using “turbidity-free” water. Formazin Stock Suspension may be prepared by the user (Ref. A.W.W.A. “Standard Methods 17th Edition”) or it may be purchased in kit form — H.F. Scientific Part No. 50040.

Each kit contains:

<u>Contents</u>	<u>Units</u>	<u>Qty.</u>
Instruction Manual	ea.	1
Formazin 4000 NTU Stock Solution	500 ml	2
Turbidity-free 0.02 NTU water	gal/4L	1
Selected Cuvettes	ea.	4
Cuvette caps	ea.	4
Reference Standard	ea.	1
Pipettes graduated 1ml, 10ml, 25ml	set	1

Shake Formazin Stock Suspension each time before pipetting to insure even dispersion of the suspension. Rinse cuvettes with solution they are to contain.

The following table gives the relationship between dilutions of the stock suspension and NTU’s. Be sure to adequately mix the stock suspension prior to removing a portion for dilution.

<b>NTU value</b>	<b>Pipette</b>	<b>Amount</b>	<b>Base Formazin</b>	<b>Volumetric Flask</b>
8.0 NTU	10.0ml	2.0ml	of 4000 NTU	1000ml
800.0 NTU	10.0ml	20.0ml	of 4000 NTU	100ml

NOTE: 1. When the prepared samples start to flocculate, they are unreliable and fresh ones must be made. This will occur more rapidly for the lower value diluted suspensions.

(C) ELECTRONIC CALIBRATION USING HF SECONDARY STANDARDS OR FRESHLY PREPARED FORMAZIN SOLUTIONS

Before calibration is attempted, it is important to note that all the calibration potentiometers (reference adjust, linearity, span) are inter-related. That is, adjusting one will also affect the value of the other ranges slightly.

1. Prepare, on the day of calibration, standards of 8 and 800 NTU using the dilution chart in this manual under Section IV. A.
2. Clean, with “Kimwipes” and windex, the reference standard and the 8 and 800 NTU standards.
3. To locate the calibration potentiometers, remove one screw and loosen the other from the access cover and turn it to the side.
4. Set the range selector switch to the 1 range. Standardize the instrument as described in this manual under Section III B. If your reference standard has never been indexed or if it is a new reference standard index it at this time (review Section III. B., Reference Standard Indexing, in this manual).
5. Set the range selector switch to the 10 range. Insert the 8 NTU standard. Note the reading on the digital display.
6. Set the range selector switch to the 1000 range. Insert the 800 NTU standard. Note the reading on the digital display.
7. Before making any adjustments remember that the calibration potentiometers affect each other slightly. Here is an example calibration:
  - a) Set range selector switch to the 1000 range. Insert the 800 NTU standard. Adjust span potentiometer (1000 range, 800 NTU standard) until the digital display reads 800 NTU  $\pm 10$  NTU.
  - b) Then set the range selector switch to the 10 range. Insert the 8 NTU standard. Adjust linearity (10 range, 8 NTU standard) to make the 8 NTU standard read approximately 8 NTU on the digital display.
  - c) Re-standardize instrument.
  - d) Repeat steps 5 & 6. If the 8 NTU standard is not 8 NTU  $\pm 1$  NTU or the 800 NTU standard is not 800 NTU  $\pm 10$  NTU then repeat step 7 a thru d until the instrument reads the correct value for all standards with no further adjustments required.

V. FEATURES INCLUDED WITH THE 20052 RESEARCH MODEL

(A) ADJUSTABLE SET POINT ALARM CONTROL

This feature provides “Dry” contact closure when the measured value exceeds a preset limit. In addition to the dry contact closure, the DRT-100B has a red lamp on the front of the unit that illuminates when the current NTU readings exceed the alarm limit. This limit can be set by placing the three position “ALARM” switch labeled “SET”, “OFF”, “NORM” to the “SET” position. The potentiometer behind the face plate is then adjusted through a hole in the face plate until the digital display shows the desired value. The “ALARM” switch is then returned to the “NORM” position. At anytime, the alarm limit currently set in the instrument may be determined by moving the “ALARM” switch to the “SET” position and reading the digital display.

Three terminals (“NC”, “C”, “NO”) are located on the rear panel and are used to connect the user’s alarm circuit. These contacts are rated at 5 amps at 110 VAC, 2.5 amps at 230 VAC. The switch may be set to “OFF” to deactivate these contacts during Standardization or Calibration to prevent false alarms.

(B) RECORDER OUTPUT, 0 - 1 MA

This output is obtained through the mini-phone jack marked “0 - 1 mA” on the rear panel of the instrument. (Mating plug supplied in accessory kit).

(C) FLOW-THRU UNIT FOR CONTINUOUS MEASUREMENT

This feature allows the continuous measurement of the turbidity of a process. The cell will accept a maximum pressure of 60 p.s.i., and a maximum flow rate of 1.5 U.S. g.p.m. The speed of response to a change in process turbidity will, of course, depend on the length of the tubing connecting the measuring head to the process, and therefore this tubing should be kept as short as possible.

Should air or gas bubbles be present in the tubing from the process, the Flow Clamp (Part #50004) should be placed on the effluent tubing and adjusted to provide enough back pressure to eliminate all bubbles.

The EPA recommends that cuvettes used for instrument calibration, standardization or sample measurement be indexed. For quick indexing of the flow through cuvette a rotational flow through assembly with locking collar has been installed.

To index your flow through cuvette, slowly rotate the flow head at least one revolution, while observing the reading and locate the position of lowest reading. Without moving the flow head, press down the flow head and turn the locking collar until the flow through assembly is securely locked in place.

(D) ATTENUATION MEASUREMENT

This feature may be used for measurements in excess of 1000 NTU’s. Set the “ATTN. - NTU” switch to “ATTEN”. The instrument is now in the light attenuation mode and the side detectors are not in the circuit.

Relative measurements can now be made. Known samples should be compared to readings on the digital display and a graph drawn that will allow the user to determine process values (e.g., p.p.m. suspended solids) from readings on the digital display.



(E) CONTROL OUTPUT, 4 - 20 MA

This feature, which would be used in conjunction with the “Flow Through Unit” feature (Part #50028) provides a control output that varies with changing measured values of a continuous process. The control output is obtained through the mini-phone jack marked “4 - 20 mA” on the rear panel of the instrument. Low and high adjustments for setting desired actuation of the control element for other ranges are located behind the access cover on the front of the instrument.

VI. OPTIONAL FEATURE

Well Adapter for 16 mm cuvette measurement (Catalog No. 20115).

This feature is for use in applications where the sample size is limited, or where the turbidity of the measured value is sufficiently great that all the light is absorbed in the greater volume of the 28 mm cuvette. (NOTE: The approximate volumes required for measurement in the two different cuvettes are 10 ml, in the 16 mm cuvette, and 25 ml in the 28 mm cuvette.)

Figure 2

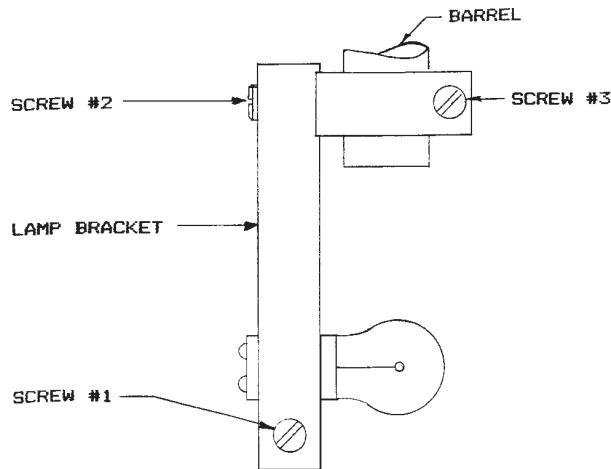

Lamp shown here from top view.

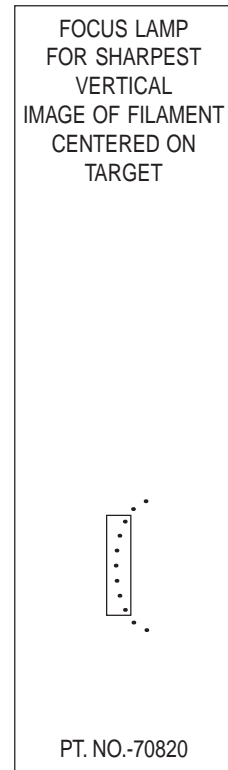

**\*NOTE:** Dotted line shown represents lamp filament image.

## VII. SOURCE LAMP REPLACEMENT & ALIGNMENT

Turn instrument power OFF and disconnect power source. Remove cover from instrument by unscrewing collar ring on top surface. (Spanner Wrench provided.) Remove the range switch knob (Hex key wrench provided) and six (6) screws from the sides of the cover. Also remove nut and washer from alarm set switch. (older models) Remove the four (4) screws that secure heat shield to chassis. Remove heat shield.

The lamp is removed by loosening Screw #1 and removing the electrical leads from TB2 - 5 & 6. Insert new lamp assembly in place and reconnect electrical leads. The lamp should be positioned so the filament is perpendicular to the baseplate of the instrument. The new lamp must now be aligned and focused. Insert lamp alignment tool, HF catalog number 70820, into the Optical Well. Turn instrument on to 1000 NTU range. Position the lamp so that an image of the filament falls within the rectangular box on the lamp alignment tool. If necessary, the height of the filament image may be adjusted by loosening Screw #2. Loosen Screw #3 and move lamp bracket assembly in or out until a narrowly focused image of the filament is obtained within the rectangular box. Once the filament image has been aligned and focused, tighten Screws #1, 2, and 3 snugly. Check the focus and alignment to be certain no movement had taken place during tightening of the screws.

**\*IMPORTANT** - Do not tighten Screw #1 too much as it may crush the base of the lamp.

Replace heat shield. Position the cover in place over the instrument and replace the screws, the knobs, the rubber gasket, the locking collar, and alarm set switch nut and washer. (older models)

VIII. ACCESSORIES & SUPPLIES

<u>PART #</u>	<u>DESCRIPTION</u>
20469	PC Board Assy (20012)
20470	PC Board Assy (20052)
20702	Reference Adjust Potentiometer
20973	Fuse, 5 x 20 mm ½A SLO-BLOW (110-120 volt operation)
21001	Lamp Bracket Assy
20850	Photo Diode
21460	Case Accessory (Empty)
60002	Reference Standard
50096	Lamp Assembly 2/pk.
50027	Instruction Manual DRT-100B
50051	Cuvette, Selected, 28 x 70 mm, 3 Pk.
20115	16mm adapter kit (Factory installed only)
20955	Fuse, 5 x 20 mm ½A quick-acting (220-240 volt operation)
20492	PC Board Assembly (20012) S/N 27007 and higher
20493	PC Board Assembly (20052) S/N 27317 and higher
19887	Secondary Standard Kit
50122	Spanner Wrench (collar removal)

This page was intentionally left blank.

## WARRANTY

HF scientific, inc., as vendor, warrants to the original purchaser of the instruments to be free of defects in material and workmanship, in normal use and service, for a period of one year from date of delivery to the original purchaser. HF scientific, inc.'s, obligation under this warranty is limited to replacing, at its factory, the instrument or any part thereof. Parts which by their nature are normally required to be replaced periodically, consistent with normal maintenance, specifically lamps including fluorescent backlight, reagent, desiccant, sensors, electrodes and fuses are excluded. Also excluded are accessories and supply type items.

Original purchaser is responsible for return of the instruments, or parts thereof, to HF scientific, inc.'s factory. This includes all freight charges incurred in shipping to and from HF scientific, inc.'s factory.

HF scientific, inc. is not responsible for damage to the instrument, or parts thereof, resulting from misuse, negligence or accident, or defects resulting from repairs, alterations or installation made by any person or company not authorized by HF scientific, inc.

HF scientific, inc. assumes no liability for consequential damage of any kind, and the original purchaser, by placement of any order for the instrument, or parts thereof, shall be deemed liable for any and all damages incurred by the use or misuse of the instruments, or parts thereof, by the purchaser, its employees, or others, following receipt thereof.

Carefully inspect this product for shipping damage, if damaged, immediately notify the shipping company and arrange an on-site inspection. HF scientific, inc. cannot be responsible for damage in shipment and cannot assist with claims without an on-site inspection of the damage.

This warranty is given expressly and in lieu of all other warranties, expressed or implied. Purchaser agrees that there is no warranty on merchantability and that there are no other warranties, expressed or implied. No agent is authorized to assume for HF scientific, inc. any liability except as above set forth.

HF scientific, inc.  
3170 Metro Parkway  
Fort Myers, Florida 33916-7597  
Phone: (941) 337-2116  
Fax: (941) 332-7643