

Model 2M2 DWB

Duo-Clozure™ Washing Machine Wall Box Rough-In Kit

Size: 1/2" (15mm)

Description

The Watts Model 2M2 DWB Duo-Clozure™ Washing Machine Wall Box (Fig. 1) consists of a molded plastic enclosure with top and side knockouts that accept the hot and cold water supply piping as well as a 1/2" (40mm) and 2" (50mm) drain knockout to accommodate the waste drain pipe. The Duo-Clozure™ incorporates a Watts Model 2M2 Duo-Cloz™ Washing Machine Shutoff Valve that simultaneously controls the flow of both hot and cold water to the appliance. The Duo-Clozure™ trim plate can be decorated to blend in with the wall finish.

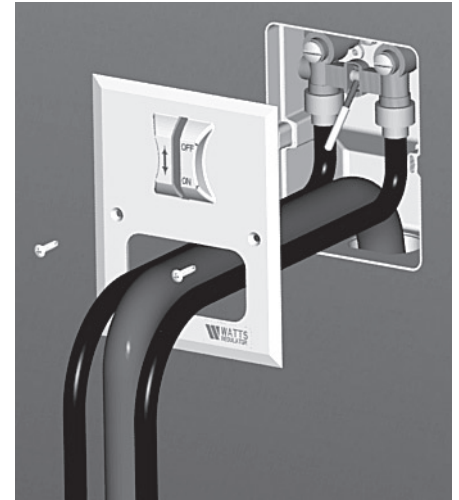
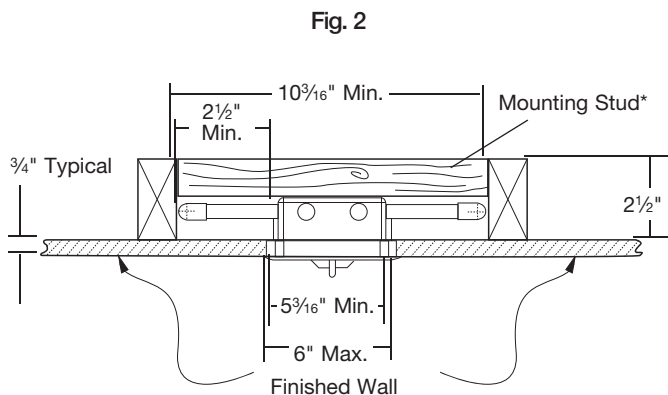

Fig. 1

Installation Instructions

CAUTION: Be sure to install the Duo-Clozure™ so that the "On-Off" lever is above the top of the washing machine.

1. Determine the location to install the Duo-Clozure™ wall box, Fig. 2. Be sure that the Duo-Cloz™ valve lever is located above the top of the washing machine and is accessible to operate the valve. (Suggested minimum height from the bottom of the mounting stud to the finished floor is 41 inches, Fig. 3.)



*Stud Not Required with 2M2 DWB Rough-In Kit-BR

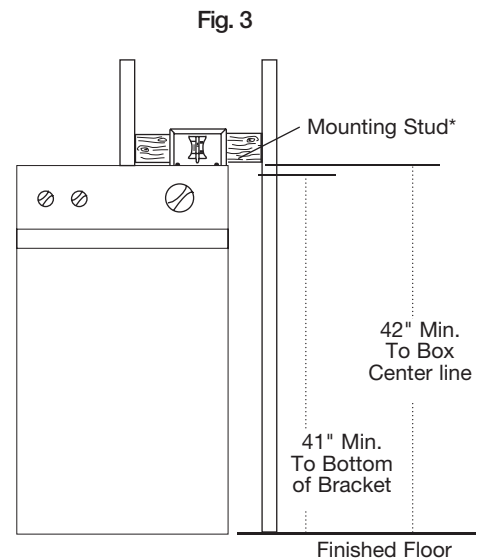

2. Prior to mounting the box, determine which inlet position will be used (side or top). Remove the appropriate knockouts. Then determine the drain size needed and follow the procedure below, Fig. 4.
 - A. For a 1½" (40mm) drain tubing, remove 1½" (40mm) knockout only.
 - B. For 2" (50mm) drain tubing, remove 1½" (40mm) and 2" (50mm) knockouts.
3. Position mounting straps in tabs on side of wall box, Fig. 5. The face of the Duo-Closure™ wall box should protrude by the depth of the finished wall, as shown in Fig. 5.

Fig. 4

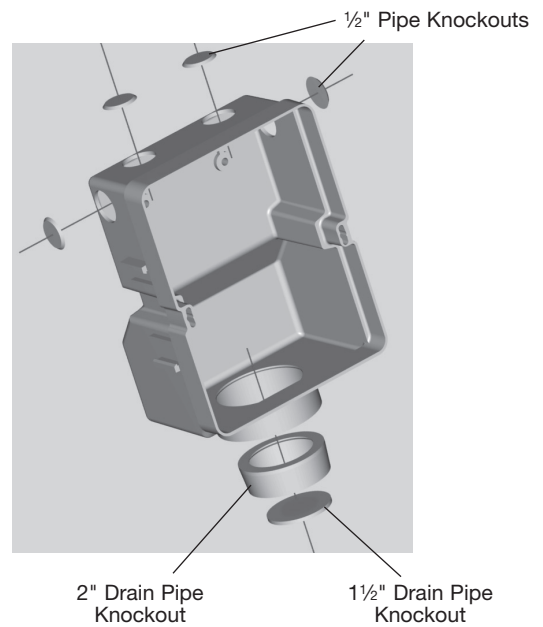
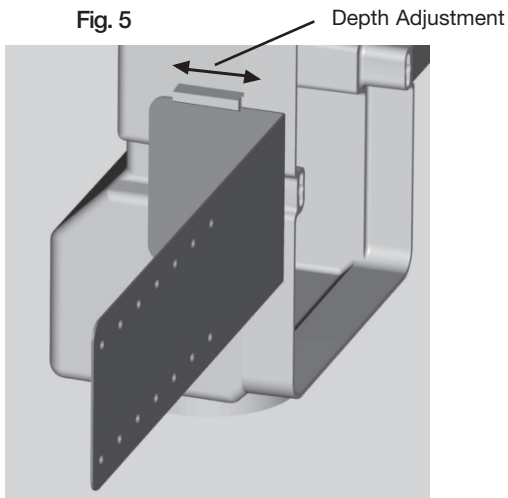
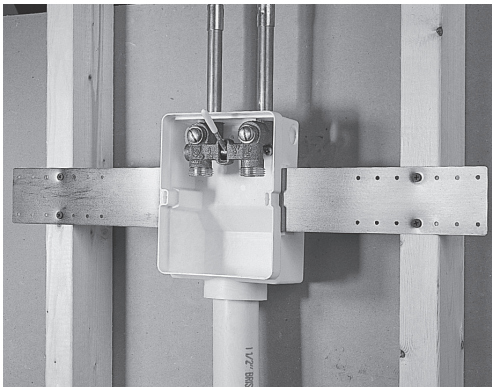

Fig. 5



2M2 DWB Rough-BR

Top Installation
Fig. 6



Side Installation
Fig. 7

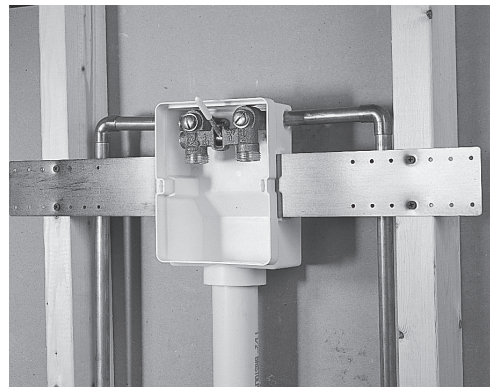

2M2 DWB-Rough

Top Installation
Fig. 8

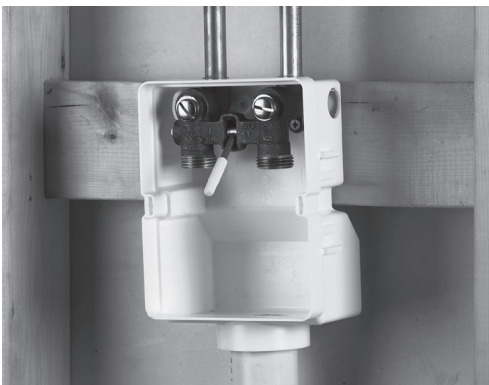

Side Installation
Fig. 9

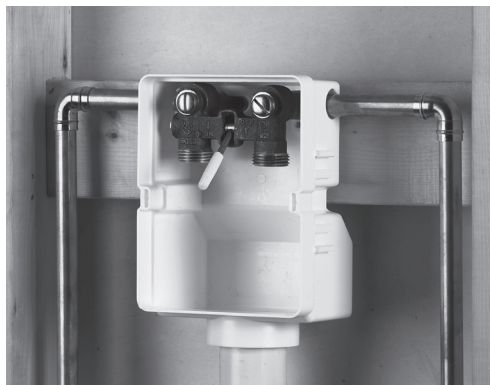

4. Level the wall box and fasten it to the mounting stud Fig. 10 and Fig. 11.

5. Install drain tubing and trap as required by local codes.

6. Solder a piece of 1/2" copper tubing to the sweat ells provided, Fig. 12 and 13.

A. **Warning: do not sweat pipe in Duo-Clozure™ wall box.** Extreme heat from a torch will deform or melt the wall box.

B. Clean pipe and ells with steel wool prior to soldering.

C. If service stops are required by code, see Fig. 14.

7. Secure ells to Duo-Clozure™ wall box with screws provided. Complete installation of hot and cold water lines to the system.

Fig. 10



Fig. 11

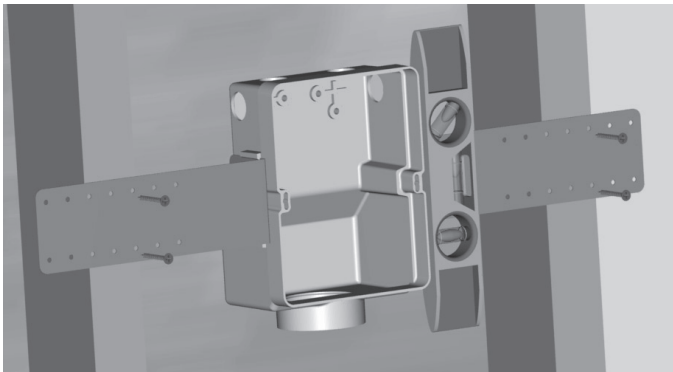

Fig. 12



Fig. 13

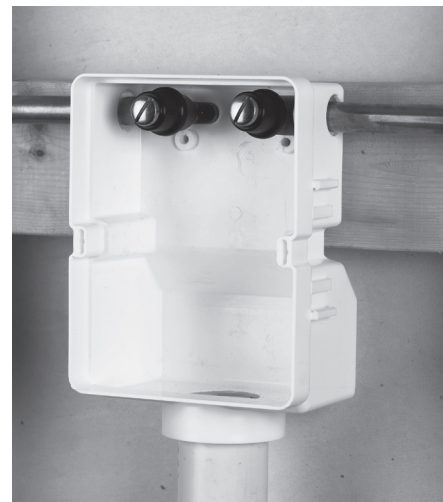

Fig. 14

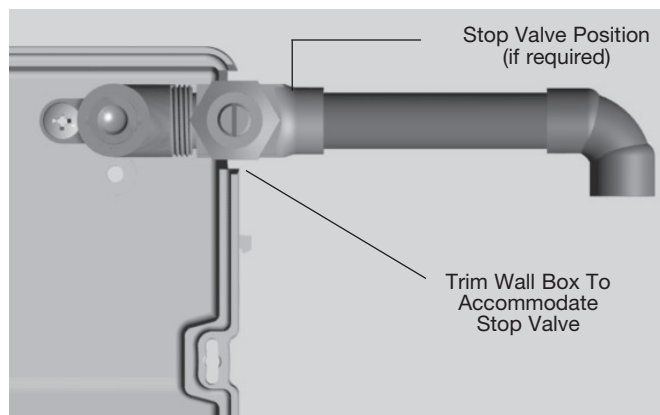

Fig. 15

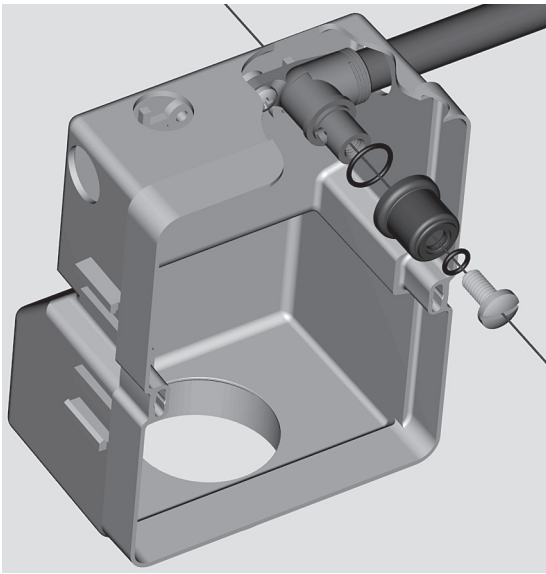

Fig. 16

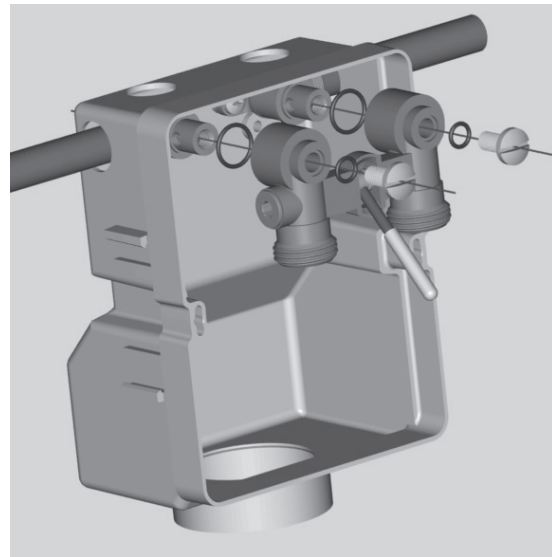
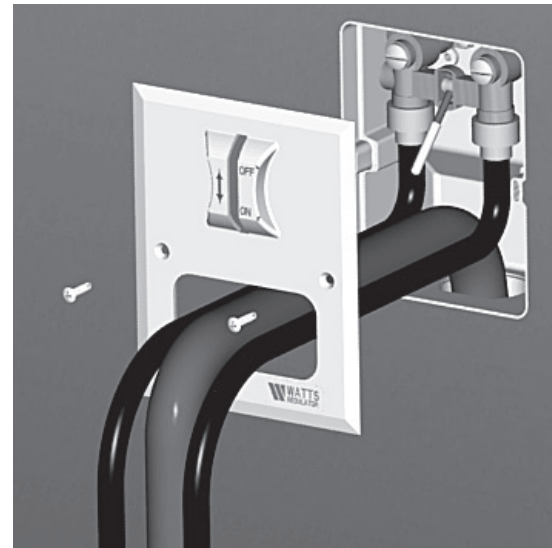

Fig. 17



8. Pressure test the system piping prior to completing the installation by using the test cap kit provided.
 - A. Install cap with O-rings and screws provided, Fig. 15, and Fig. 16 turn on the water.
9. Next, install the cardboard plaster guard in the wall box to protect components from plaster and paint.
10. The Duo-Cloz™ valve and trim plate are included in the 2M2 DWB™ finish kit which can be installed upon completion of the finished wall, Fig. 17.

Note: The Duo-Clozure™ trim plate can be decorated to blend in with the finished wall. The Duo-Cloz operating lever will accept most female threaded decorative knobs. The white plastic lever protector can be slipped off exposing male #8-32" threads.

CALIFORNIA PROPOSITION 65 WARNING

WARNING: This product contains chemicals known to the State of California to cause cancer and birth defects or other reproductive harm. (California law requires this warning to be given to customers in the State of California.)

For more information: www.watts.com/prop65

Limited Warranty: Watts Regulator Co. (the "Company") warrants each product to be free from defects in material and workmanship under normal usage for a period of one year from the date of original shipment. In the event of such defects within the warranty period, the Company will, at its option, replace or recondition the product without charge.

THE WARRANTY SET FORTH HEREIN IS GIVEN EXPRESSLY AND IS THE ONLY WARRANTY GIVEN BY THE COMPANY WITH RESPECT TO THE PRODUCT. THE COMPANY MAKES NO OTHER WARRANTIES, EXPRESS OR IMPLIED. THE COMPANY HEREBY SPECIFICALLY DISCLAIMS ALL OTHER WARRANTIES, EXPRESS OR IMPLIED, INCLUDING BUT NOT LIMITED TO THE IMPLIED WARRANTIES OF MERCHANTABILITY AND FITNESS FOR A PARTICULAR PURPOSE.

The remedy described in the first paragraph of this warranty shall constitute the sole and exclusive remedy for breach of warranty, and the Company shall not be responsible for any incidental, special or consequential damages, including without limitation, lost profits or the cost of repairing or replacing other property which is damaged if this product does not work properly, other costs resulting from labor charges, delays, vandalism, negligence, fouling caused by foreign material, damage from adverse water conditions, chemical, or any other circumstances over which the Company has no control. This warranty shall be invalidated by any abuse, misuse, misapplication, improper installation or improper maintenance or alteration of the product.

Some States do not allow limitations on how long an implied warranty lasts, and some States do not allow the exclusion or limitation of incidental or consequential damages. Therefore the above limitations may not apply to you. This Limited Warranty gives you specific legal rights, and you may have other rights that vary from State to State. You should consult applicable state laws to determine your rights. **SO FAR AS IS CONSISTENT WITH APPLICABLE STATE LAW, ANY IMPLIED WARRANTIES THAT MAY NOT BE DISCLAIMED, INCLUDING THE IMPLIED WARRANTIES OF MERCHANTABILITY AND FITNESS FOR A PARTICULAR PURPOSE, ARE LIMITED IN DURATION TO ONE YEAR FROM THE DATE OF ORIGINAL SHIPMENT.**



Water Safety & Flow Control Products



USA: 815 Chestnut St., No. Andover, MA 01845-6098; www.watts.com

Canada: 5435 North Service Rd., Burlington, ONT. L7L 5H7; www.wattscanada.ca