

# High Purity Piping Systems

Polypropylene (WLPP, STDPP) and  
Polyvinylidene Fluoride (WLPVDF)





<b>Table of Contents</b> .....	<b>1</b>
<b>1. Resins &amp; Materials.</b> .....	<b>2-5</b>
A Choice of Resins. ....	2
Orion HP Polypropylene Systems Features. ....	2
Orion PVDF Systems Features .....	2
Resins, Valves & Joining Systems. ....	3
Polypropylene (PP), Polyvinylidene Fluoride (PVDF) Features & Advantages .....	4-5
<b>2. High Purity Joining Methods</b> .....	<b>6</b>
Socket Fusion. ....	6
<b>3. High Purity Submittals</b> .....	<b>7-9</b>
PPI .....	7
PPII .....	8
PVDF .....	9
<b>4. High Purity Pipe</b> .....	<b>10</b>
<b>5. High Purity Fittings</b> .....	<b>11-15</b>
<b>6. High Purity Flex Connectors</b> .....	<b>16</b>
<b>7. High Purity Faucets</b> .....	<b>17-19</b>
<b>8. High Purity Recirculating Faucets</b> .....	<b>20-21</b>
<b>9. High Purity Leachables</b> .....	<b>22-25</b>
<b>10. High Purity Piping Physical Properties</b> .....	<b>26-27</b>
<b>11. High Purity Installation Guidelines</b> .....	<b>28-29</b>
<b>12. High Purity Whiteline Testing Procedures</b> .....	<b>30</b>
<b>13. High Purity Design Data</b> .....	<b>31-35</b>
<b>14. High Purity Assembly</b> .....	<b>36-37</b>
<b>15. High Purity Valve Welding/O &amp; M</b> .....	<b>38-39</b>
<b>16. Terms &amp; Conditions</b> .....	<b>40</b>

**⚠ WARNING**

Local building or plumbing codes may require modifications to the information provided. You are required to consult the local building and plumbing codes prior to installation.

## A Choice of Resins

For many engineers and contractors, Orion Polypropylene (PP) and Polyvinylidene Fluoride (PVDF) high purity systems have been the products they've specified and installed for years. Plumbing professionals know that dependable Orion Standard Line, Whiteline and PVDF high purity products can be counted on to provide the peace of mind their clients expect. Orion offers a choice of materials that make it easy to custom-design systems to meet the exacting standards required for high purity piping systems.

Orion Whiteline systems are manufactured from pure Type I Homopolymer PP and use no anti-oxidants, pigments or other foreign substances often associated with plastic piping products. The result is an ideal system for the transportation of deionized distilled water or other liquids where a high degree of purity is required. Each length of pipe and all fittings are bagged.

Orion PVDF systems are manufactured from Kynar<sup>®</sup> brand of Polyvinylidene Fluoride (PVDF). The resin contains no plasticizers, colorants, stabilizers, impurities or other additives that could seep into the liquid being transported, contaminating it. In critical ultra high purity liquid transportation applications, PVDF is the clear choice.

Orion high purity systems are easily joined by socket fusion connections, providing a truly sealed system ensuring protection from outside impurities and tampering. These systems allow complete control over transportation of high purity materials from source to end use without fear of leaching or other contamination.

## Orion HP Polypropylene Systems Features

- Lower cost than competitive systems
- No metallics
- Withstands high temperatures to 180°F (82°C)
- All standard pipe sizes available
- Complete piping and accessories available from Orion
- Excellent chemical resistance
- Smooth surfaces for less flow resistance
- Non-porous surfaces means no bacterial growth

## Orion PVDF Systems Features

- Exceptional chemical and abrasion resistance
- Elevated temperature rating of 280°F (38°C)
- High resistance to gamma radiation
- Total resistance to ultraviolet radiation
- Highly transparent to ultraviolet radiation
- Will not support growth of fungi
- Smooth surfaces that do not allow the collection of bacteria and fungi
- UL94 V-O

### Resins

- Polypropylene (PP)
- Polyvinylidene Fluoride (PVDF)

### Valves

- Tru-Union Ball check valves
- Tru-Union ball valves
- Needle valves
- Diaphragm valves

### Joining System

- Socket fusion



## Polypropylene (PP)

Orion Whiteline systems are manufactured from pure, virgin Type I Homopolymer Polypropylene. No antioxidants, pigments or other foreign substances are added to the resin in the manufacture process. This manufacturing process produces a reliable system for high purity applications.

Orion Standardline systems are manufactured from virgin Type II Copolymer Polypropylene and can be used where purity standards are less stringent.

## Polypropylene (PP) Advantages

- Specific Gravity - PP is the lightest of all plastics, weighing approximately two-thirds the weight of PVC and one-eighth the weight of steel.
- Tensile Strength - PP is the strongest of the Polyolefin resins. This strength is retained over a wide range of temperatures e.g. at 200°F (93°C) tensile strength is 1700 psi.
- Flexural Strength - PP is classed as a rigid plastic.
- Hardness - PP provides good abrasion resistance.
- Heat Distortion - the heat distortion temperature of PP is the highest of all the low-cost plastics. Its maximum use temperature is higher than other Polyolefins, PVC, and other low-cost plastics.
- Thermal Properties - PP is one of the best plastic insulators.
- Electrical Properties - PP is rated excellent.
- Impact Strength - PP has an intermediate impact strength with respect to normal and impact PVC; impact decreases with lower temperatures.
- Ultraviolet Stability - None. Orion high purity systems contain no ultraviolet inhibitor and must be protected from direct sunlight or ultraviolet rays.
- Burn Characteristics - PP is classed as slow burning. It is stress-crack resistant unlike linear polyethylene.

## High Purity Materials

### Polyvinylidene Fluoride (PVDF)

Orion's Ultra high purity system is for those critical high purity liquid transportation situations when you absolutely, positively cannot tolerate extractables. It is manufactured from 100% pure, virgin, KYNAR<sup>®</sup> PVDF (Polyvinylidene Fluoride) resin.

### Features

- Non-leaching—PVDF adds no detectable leachants or other contaminants to solutions.
- Smooth walls—The extra smooth walls PVDF produces help assure turbulent-free flow of liquids and prevent the collection and breeding of fungi, bacteria and other biological impurities.
- Chemical resistance—PVDF offers excellent chemical resistance to: weak acids, strong acids, oxidizing acids, mixed acids, organic solvents and many aggressive gases. Such resistance makes it an ideal choice for severe applications such as: chemical; cosmetic; pharmaceutical; educational; medical.

- Extended operating range—PVDF is able to maintain a high degree of its strength and chemical resistance within a temperature range of -40°F (-40°C) to 280°F (138°C).
- Durability—PVDF's high density (up to twice as dense as polypropylene) means it can take lots of abuse. That makes it an ideal choice in vibration—or impact-prone applications.
- Aging and stability—PVDF is designed to withstand direct sunlight—or be buried—while retaining its physical properties for a minimum of 20 years.
- Fungus resistance—PVDF will not support growth of fungi when tested by Method 508 of MIL STD 810.



## Socket Fusion

### The Time Tested System from Orion

Socket fusion systems are durable, strong and tamper-proof. Heat fusion forms a complete hermetically sealed system which makes socket fusion systems ideal for severe usage applications. Socket fusion type pipe and fittings are joined by heat fusing the material with an Orion thermostatically controlled heat tool. In a semi-molten state, pipe and fittings are easily joined to form a strong and permanent sealed joint.

## Features

- Fast and easy to install. Only 15-35 seconds per joint is all it takes after the heat-fusing tool has warmed up.
- Completely sealed for strength and durability.
- Forms true hermetically sealed joint.
- All identical material, no electrolysis, no metal in joint
- Ideal for severe use applications.
- Orion fusion systems meet ASTM D2657 standards in their entirety.



## Whiteline Polypropylene (PPI) Socket Fusion

### Pipe:

#### **Orion Whiteline Pipe Schedule 80**

Pipe will be manufactured to Schedule 80 iron pipe dimensions from virgin unpigmented Type I homopolymer polypropylene, meeting ASTM D4101, using no plasticizers or antioxidants. Pipe will be furnished in 10' lengths, capped. Pipe will meet the dimensional tolerances of ASTM D2447.

### Fittings:

#### **Orion Whiteline Socket Fusion**

Fittings will be manufactured to Schedule 80 wall thickness from virgin unpigmented Type I homopolymer polypropylene, meeting ASTM D4101, using no plasticizers or antioxidants. Fittings will be manufactured to be joined by the socket fusion heat method, conforming to ASTM D2657. All fittings test to 150 psi @ 73°F (23°C). Each fitting will be individually bagged.

### Ball Valves:

#### **Orion Whiteline Socket Fusion**

Ball valves will be manufactured from virgin unpigmented Type I homopolymer polypropylene to be fully compatible with the Orion high purity Whiteline system. All valves will test to 150 psi @ 73°F (23°C). Each ball valve will be individually bagged.

### Ball Check Valves:

#### **Orion Whiteline Socket Fusion**

Ball check valves will be manufactured from virgin unpigmented Type I homopolymer polypropylene to be fully compatible with the Orion high purity Whiteline system. All valves will test to 150 psi @ 73°F (23°C). Each ball valve will be individually bagged.

### Needle Valves:

#### **Needle Valves**

Needle valves will be manufactured from virgin unpigmented polypropylene resin meeting ASTM D4101 to be fully compatible with the Orion high purity system. Each valve shall be individually packaged and sealed.

### Diaphragm Valves:

#### **Diaphragm Valves**

Diaphragm valves will be manufactured from virgin unpigmented polypropylene resin meeting ASTM D4101 to be fully compatible with the Orion high purity polypropylene system. All diaphragm valves shall test to 150 psi at 73°F (23°C). All valves shall be individually bagged.

## Standardline Polypropylene (PPII) Socket Fusion

### Pipe & Fittings: Orion Standardline

Pipe & Fittings shall be manufactured to Schedule 80 iron pipe dimensions, from natural unpigmented virgin polypropylene copolymer (Type II) material. Pipe material shall meet ASTM D4101 and shall be manufactured to meet dimensional tolerances of ASTM D2447. The joining method shall be socket fusion using Orion tools producing a fusion joint meeting ASTM D2657. Pipe will be furnished in 10' lengths.

### Ball Valves:

#### **Orion Whiteline Socket Fusion**

Ball valves will be manufactured from virgin unpigmented Type I homopolymer polypropylene to be fully compatible with the Orion high purity Whiteline system. All valves will test to 150 psi @ 73°F (23°C). Each ball valve will be individually bagged.

### Ball Check Valves:

#### **Orion Whiteline Socket Fusion**

Ball check valves will be manufactured from virgin unpigmented Type I homopolymer polypropylene to be fully compatible with the Orion high purity Whiteline system. All valves will test to 150 psi @ 73°F (23°C). Each ball valve will be individually bagged.

### Diaphragm Valves

Diaphragm valves will be manufactured from virgin unpigmented polypropylene resin meeting ASTM D4101 to be fully compatible with the Orion high purity polypropylene system. All diaphragm valves shall test to 150 psi at 73°F (23°C). All valves shall be individually bagged.

## Polyvinylidene Fluoride (PVDF) Socket Fusion

### Pipe:

#### Orion PVDF Pipe

Pipe will be manufactured to Schedule 80 iron pipe dimensions from virgin, unpigmented PVDF resin, meeting ASTM D3222, using no plasticizers or pigments. Pipe will be furnished in 10' lengths, grooved and capped. Pipe will meet all dimensional tolerances of ASTM D2447.

### Fittings:

#### Orion PVDF Fittings

Fittings will be manufactured to Schedule 80 wall thickness from virgin unpigmented PVDF (polyvinylidene fluoride) resin meeting ASTM D3222. Fittings are to be joined by using the socket fusion method, conforming to ASTM 2657. Each fittings will be individually packaged and sealed.

### Ball Valves:

#### Orion PVDF

Ball valves will be manufactured from virgin unpigmented PVDF (polyvinylidene fluoride) to be fully compatible with the Orion high purity PVDF system. All valves test to 150 psi @ 73°F (23°C). Each ball valve will be individually bagged.

### Ball Check Valves:

#### Orion PVDF

Ball check valves will be manufactured from virgin PVDF (polyvinylidene fluoride) to be fully compatible with the Orion high purity PVDF system. All valves will test to 150 psi @ 73°F (23°C). Each valve will be individually bagged.

### Diaphragm Valves

Diaphragm valves will be manufactured from virgin unpigmented PVDF (polyvinylidene fluoride) resin meeting ASTM D3222 to be fully compatible with the Orion high purity PVDF system. All diaphragm valves shall test to 150 psi at 73°F (23°C). All valves shall be individually bagged.

Available in PPI, PPII or PVDF

Note: Extended sizes including 3", 4" and 6" are available by special approval.  
Contact [oriontechs@wattswater.com](mailto:oriontechs@wattswater.com) for more information.

**Note:** All dimensions are +/- 0.25"  
All weights are approximate.

## Pipe

Schedule 80	Average OD	Wall Thickness	Weight per Stick (lb.)		Sticks per Bundle	
			PP	PVDF	PP	PVDF
1/2	0.84	0.147	1.5	2.67	10	10
3/4	1.05	0.154	1.8	3.50	10	10
1	1.315	0.179	2.9	5.25	10	10
1 1/2	1.900	0.200	4.6	8.50	10	5
2	2.375	0.218	5.9	12.00	10	5

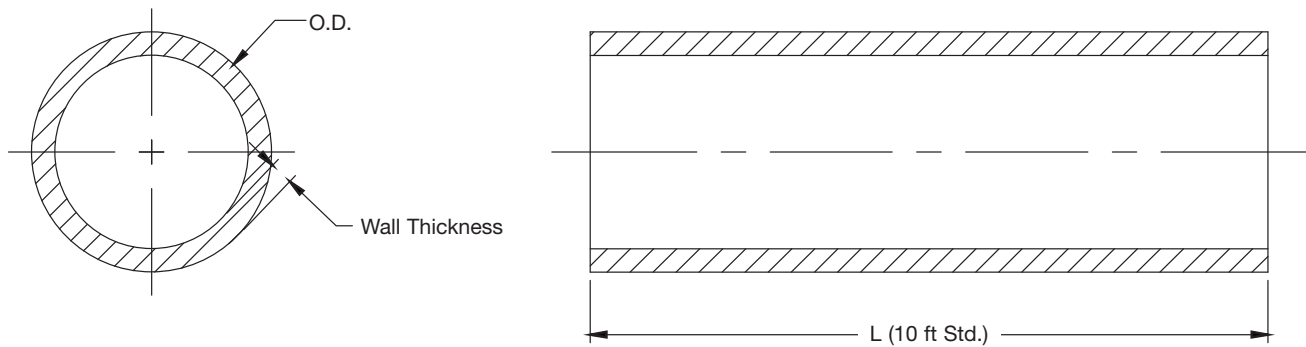

Available in PPI, PPII or PVDF

Note: Extended sizes including 3", 4" and 6" are available by special approval.  
Contact [orientechs@wattswater.com](mailto:orientechs@wattswater.com) for more information.

**Note:** All dimensions are +/- 0.25"  
All weights are approximate.

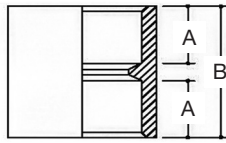

### Socket Fusion Coupling - CPLG

Size (in.)	A	B	Weight (oz.)	
			PP	PVDF
1/2	.65	1.60	.675	1.36
3/4	.65	1.60	.775	1.56
1	.70	1.60	.925	1.86
1 1/2	.88	2.07	1.950	3.92
2	.90	2.07	2.460	4.94

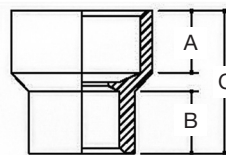

### Reducing Coupling - RCPLG

Size (in.)	A	B	C	Weight (oz.)	
				PP	PVDF
3/4 x 1/2	.70	.65	1.60	.675	1.36
1 x 1/2	.70	.65	1.60	.875	7.70
1 x 3/4	.70	.65	1.60	.825	1.66
1 1/2 x 1/2	.88	.65	2.07	.880	1.82
1 1/2 x 3/4	.88	.65	2.07	.880	1.99
1 1/2 x 1	.88	.70	2.07	1.800	3.62
2 x 1 1/2	.90	.88	2.07	2.210	4.52
2 x 1	.90	.70	2.07	2.250	5.60
2 x 1/2	.90	.65	2.07	2.500	5.60
2 x 3/4	.90	.65	2.07	2.500	5.60

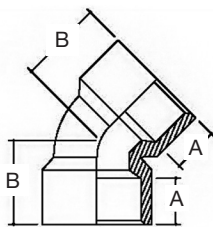

### 45° Elbow - 45E - 1/8 Bend

Size (in.)	A	B	Weight (oz.)	
			PP	PVDF
1/2	.65	1.25	.85	1.81
3/4	.65	1.25	1.10	2.11
1	.70	1.25	1.60	2.61
1 1/2	.88	1.65	2.95	4.52
2	.90	1.75	4.10	6.03

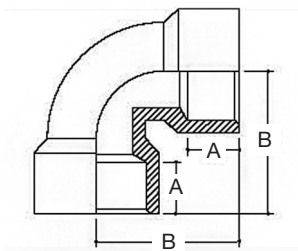

### 90° Elbow - 90E - 1/4 Bend

Size (in.)	A	B	Weight (oz.)	
			PP	PVDF
1/2	.65	1.63	.85	1.71
3/4	.65	1.80	1.10	2.21
1	.70	1.92	1.60	3.22
1 1/2	.88	2.41	2.95	5.93
2	.90	2.68	4.10	8.24

Available in PPI, PPII or PVDF

Note: Extended sizes including 3", 4" and 6" are available by special approval.  
Contact [oriontechs@wattswater.com](mailto:oriontechs@wattswater.com) for more information.

**Note:** All dimensions are +/- 0.25"  
All weights are approximate.

**Reducing Bushing - RB**

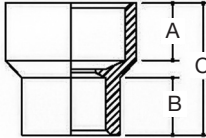

Size (in.)	A	B	Weight (oz.)	
			PP	PVDF
3/4 x 1/2	.65	1.45	.695	1.36
1 x 1/2	.65	1.45	.850	1.70
1 x 3/4	.65	1.45	.825	1.66
1 1/2 x 1/2	.60	1.70	1.850	1.94
1 1/2 x 3/4	.65	1.62	1.850	1.97
1 1/2 x 1	.70	1.63	1.800	3.62
2 x 1/2	.60	2.71	2.500	4.50
2 x 3/4	.65	2.63	2.500	4.50
2 x 1	.70	2.64	2.500	4.50
2 x 1 1/2	.88	1.89	2.500	4.52

**Tee - 90T**

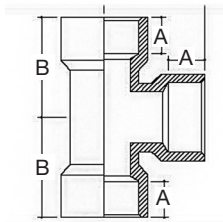

Size (in.)	A	B	Weight (oz.)	
			PP	PVDF
1/2	.65	1.62	1.15	2.31
3/4	.65	1.79	2.10	4.22
1	.70	1.93	2.10	4.22
1 1/2	.88	2.44	4.00	8.04
2	.90	2.72	5.50	11.06

**Reducing Tee - R90T**

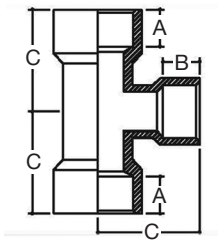

Size (in.)	A	B	C	Weight (oz.)	
				PP	PVDF
3/4 x 1/2	.65	.65	1.79	1.50	2.81
1 x 1/2	.70	.65	1.93	1.95	3.52
1 x 3/4	.70	.65	1.93	1.95	3.92
1 1/2 x 1	.88	.70	2.44	3.65	8.70
2 x 1 1/2	.90	.88	2.72	5.45	10.95

**Male Adapter - MA**

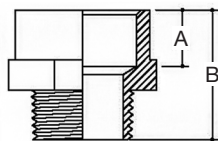

Size (in.)	A	B	Weight (oz.)	
			PP	PVDF
1/2	.65	1.60	.675	1.36
3/4	.65	1.60	.775	1.56
1	.70	1.60	.975	1.96
1 1/2	.88	2.07	1.970	3.96
2	.90	2.07	2.620	5.27

Available in PPI, PPII or PVDF

Note: Extended sizes including 3", 4" and 6" are available by special approval.

Contact [orientechs@wattswater.com](mailto:orientechs@wattswater.com) for more information.

**Note:** All dimensions are +/- 0.25"  
All weights are approximate.

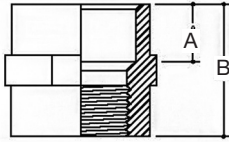

### Female Adapter - FA

Size (in.)	A	B	Weight (oz.)	
			PP	PVDF
1/2	.65	1.60	.750	1.51
3/4	.65	1.60	1.000	2.01
1	.70	1.60	1.175	2.36
1 1/2	.88	2.07	2.320	4.66
2	.90	2.07	2.920	5.87

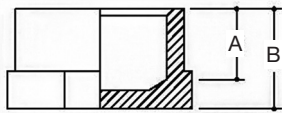

### CAP - CAP

Size (in.)	A	B	Weight (oz.)	
			PP	PVDF
1/2	.65	1.00	.650	1.31
3/4	.65	1.00	.750	1.51
1	.70	1.00	.875	1.76
1 1/2	.88	1.28	1.870	3.76
2	.90	1.28	2.510	5.05

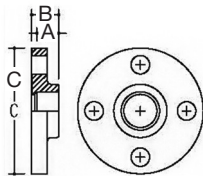

### Flange - FLG

Size (in.)	A	B	C
1/2	.63	.81	3.52
3/4	.65	.90	3.89
1	.70	.92	4.25
1 1/2	.88	1.11	5.00
2	.90	1.38	5.98

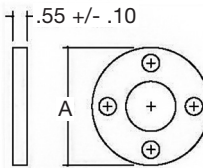

### Backup Ring

Size (in.)	A	150# ANSI Pattern Holes
1/2	3.50	4
3/4	4.00	4
1	4.25	4
1 1/2	5.00	4
2	6.00	4

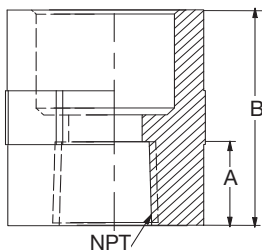

### Reducing Female Adapter - RFA

Size (in.)	A	B	Weight (oz.)	
			PP	PVDF
1/2 x 3/8	.62	1.60	0.64	1.28
1/2 x 1/4	.62	1.60	0.64	1.44

Available in PPI, PPII or PVDF

Note: Extended sizes including 3", 4" and 6" are available by special approval.

Contact [orientechs@wattswater.com](mailto:orientechs@wattswater.com) for more information.

**Note:** All dimensions are +/- 0.25"

All weights are approximate.

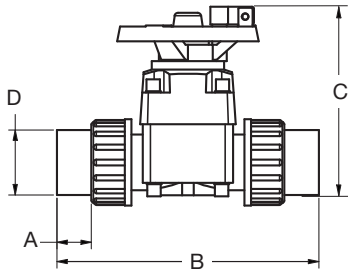

**Diaphragm Valve - DV**

Size (in.)	A	B	C	D	Weight (oz.)	
					PP	PVDF
1/2	.65	4.88	4.72	1.20	12.79	24.64
3/4	.65	5.98	5.11	1.23	19.17	26.88
1	.70	6.54	5.50	1.57	31.68	37.76
1 1/2	.88	8.62	7.36	1.97	76.32	73.76
2	.90	9.92	7.53	2.46	106.85	92.00

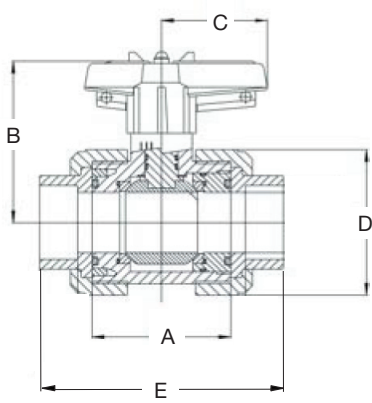

**True Union Ball Valve - BV**

Size (in.)	A	B	C	D	E	Weight (oz.)	
						PP	PVDF
1/2	2.44	2.83	1.57	2.09	3.96	5.49	10.56
3/4	2.76	3.09	2.03	2.48	4.53	8.19	15.52
1	2.91	3.21	2.03	2.76	4.97	10.66	20.48
1 1/2	3.74	4.23	2.87	3.98	6.57	24.42	50.40
2	4.29	4.59	3.35	4.78	7.80	36.48	75.52

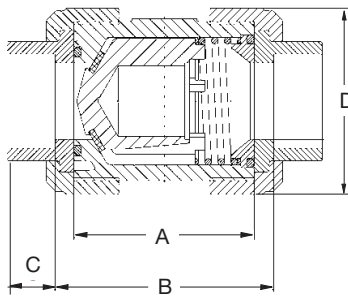

**Double Union Spring Check Valve - CV**

Size (in.)	A	B	C	D	Weight (oz.)	
					PP	PVDF
1/2	2.44	2.66	0.65	2.09	4.33	7.04
3/4	2.76	2.99	0.77	2.48	6.46	8.80
1	2.91	3.19	0.89	2.76	9.15	14.24
1 1/2	3.74	4.09	1.24	3.98	35.68	35.20
2	4.29	4.76	3.52	4.78	31.09	56.80

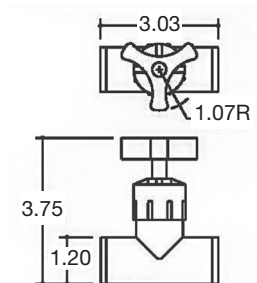

**Needle Valve - NV (PPI Only)**

Size	A
1/2	F.I.P.

Available in PP or PVDF

Note: Extended sizes including 3", 4" and 6" are available by special approval.  
Contact [oriontechs@wattswater.com](mailto:oriontechs@wattswater.com) for more information.

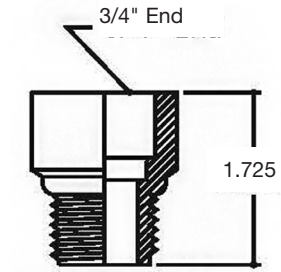

### Hose Bib - Hose

Size	Description
3/4 Soc x 3/4 - 11.5	N.R. Hose Thread

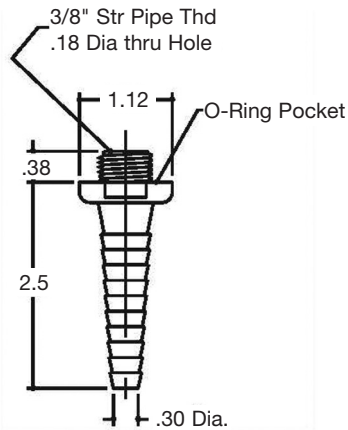

### Hose Barb - HB (PPI & PPII)

Size	Description
3/8	Hose Barb

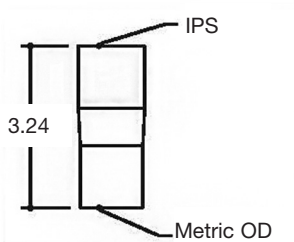

### Metric Adapter - MM

IPS x Metric Size:
1/2 x 20mm (d)
3/4 x 24mm (d)
1 x 32mm (d)
1 1/2 x 50mm (d)
2 x 63,, (d)

Available in PP or PVDF

Note: Larger sizes may be available. Contact [Orientechs@wattswater.com](mailto:Orientechs@wattswater.com)

## Ultra Pure Water Flex Connector

Orion's flex connector simplifies connecting between the rigid piping in the wall and the base of the faucet. The PVDF tubing connector allows you to make that connection with the same dependable materials as the rest of the system be it PPI, PPII or PVDF. The threaded connector can be either male or female, allowing you to easily transition from one connection to another, and eliminates the need for special tools under the counter.

## Recommended Specifications

Flex connectors are manufactured from virgin PVDF resin per ASTM D 3222. PVDF tubing is 1/2" in diameter. Threaded connectors are manufactured of the same PVDF resin.

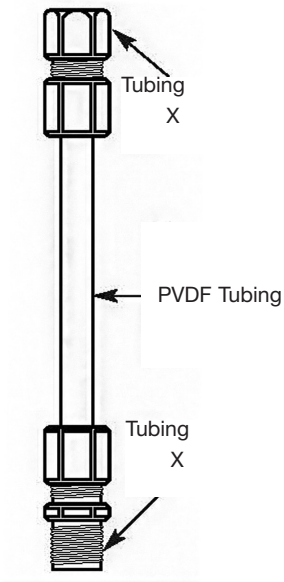

**Ultra Pure Water Flex Connector**

Callout	Description	Callout	Description
38F-12-12F	12" lg x 3/8 F.I.P. x 1/2 F.I.P.	38F-18-12F	18" lg x 3/8 F.I.P. x 1/2 F.I.P.
38F-12-12M	12" lg x 3/8 F.I.P. x 1/2 M.I.P.	38F-18-12M	18" lg x 3/8 F.I.P. x 1/2 M.I.P.
38M-12-12F	12" lg x 3/8 M.I.P. x 1/2 F.I.P.	38M-18-12F	18" lg x 3/8 M.I.P. x 1/2 F.I.P.
38M-12-12M	12" lg x 3/8 M.I.P. x 1/2 M.I.P.	38M-18-12M	18" lg x 3/8 M.I.P. x 1/2 M.I.P.
12F-12-12M	12" lg x 1/2 F.I.P. x 1/2 F.I.P.	12F-18-12F	18" lg x 3/8 F.I.P. x 1/2 F.I.P.
12M-12-12M	12" lg x 1/2 M.I.P. x 1/2 M.I.P.	12M-18-12M	18" lg x 3/8 M.I.P. x 1/2 M.I.P.
12M-12-12F	12" lg x 1/2 M.I.P. c 1/2 F.I.P.	12M-18-12F	18" lg x 3/8 M.I.P. x 1/2 M.I.P.
Callout	Description	Callout	Description
38F-24-12F	24" lg x 3/8 F.I.P. x 1/2 F.I.P.	38F-36-12F	36" lg x 3/8 F.I.P. x 1/2 F.I.P.
38F-24-12M	24" lg x 3/8 F.I.P. x 1/2 M.I.P.	38F-36-12M	36" lg x 3/8 F.I.P. x 1/2 M.I.P.
38M-24-12F	24" lg x 3/8 M.I.P. x 1/2 F.I.P.	38M-36-12F	36" lg x 3/8 M.I.P. x 1/2 F.I.P.
38M-24-12M	24" lg x 3/8 M.I.P. x 1/2 F.I.P.	38M-36-12M	36" lg x 3/8 M.I.P. x 1/2 M.I.P.
12F-24-12F	24" lg x 1/2 F.I.P. x 1/2 F.I.P.	12F-36-12F	36" lg x 1/2 F.I.P. x 1/2 F.I.P.
12M-24-12M	24" lg x 1/2 M.I.P. x 1/2 M.I.P.	12M-36-12M	36" lg x 1/2 M.I.P. x 1/2 M.I.P.
12M-24-12F	24" lg x 1/2 M.I.P. x 1/2 F.I.P.	12M-36-12F	36" lg x 1/2 M.I.P. x 1/2 F.I.P.
38M-24-12M	24" lg x 3/8 M.I.P. x 1/2 F.I.P.		

### Laboratory Faucets

Orion faucets have been used in hundreds of hospitals and research laboratories since 1965. Offering superior high purity delivery, Orion's line of laboratory faucets provides unparalleled quality and reliability for all of your high purity applications.

Orion's line of countertop and wall mounted laboratory faucets are activated by a quick-turn needle valve. Recirculating faucets and faucets with integral vacuum breakers complete the line to satisfy any high purity requirements.



### Polypropylene (PPI) Faucets

Orion's Whiteline faucets are manufactured from pure unpigmented virgin Type I homopolymer per ASTM D 4101, using no anti-oxidants, pigments or other foreign substances often associated with other plastic piping products. This provides an ideal system for the transportation of deionized, distilled and RO water or other liquids where a high degree of purity is required. Whiteline's smooth surfaces do not attract contaminants so they do not provide breeding places for bacteria and other biological impurities.

- No metallics in Orion Whiteline systems
- Ability to withstand high temperatures (210°F (99°C) max.)
- Excellent chemical resistance and non-porous surfaces

### Polyvinylidene Fluoride (PVDF) Faucets

Orion's Whiteline PVDF faucets are produced using high purity, unpigmented, natural Kynar<sup>®</sup> PVDF resin conforming to ASTM D3222. Kynar<sup>®</sup> is 100% pure PVDF containing no colorants or stabilizing additives. Independent studies have demonstrated that products manufactured from PVDF add no detectable leachants or other contaminants to test solutions. PVDF meets the most stringent industry requirements for extractables and purity levels for 18 megohm deionized water.

- Exceptional chemical and abrasion resistance
- Elevated temperature rating of 280°F (138°C)
- High resistance to gamma radiation
- Total resistance to ultra-violet radiation
- Will not support growth of fungi
- Smooth surfaces do not allow the collection of bacteria or fungi
- UL 94 V-O

**GNF 10 VB**

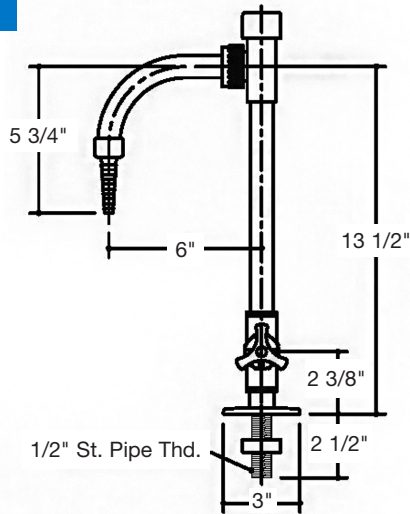

**Recommended Specifications**

Welded Assembly Deck mounted Laboratory Faucet with integral vacuum breaker manufactured from virgin unpigmented resin. Polypropylene per ASTM D 4101 PVDF per ASTM D 3222.

**GNF 30 VB**

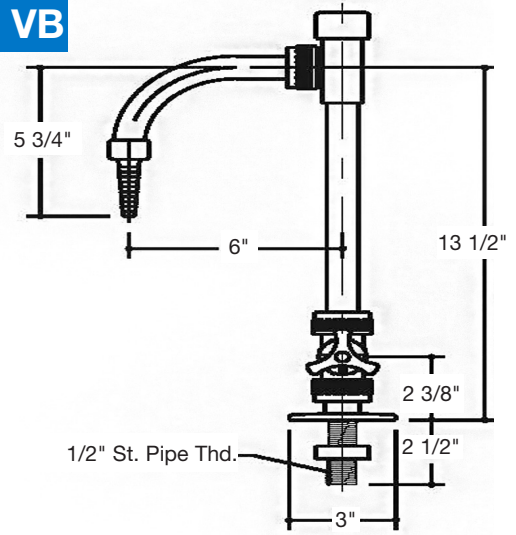

**Recommended Specifications**

Threaded Assembly Deck mounted Laboratory Faucet with integral vacuum breaker manufactured from virgin unpigmented resin. Polypropylene per ASTM D 4101 PVDF per ASTM D 3222.

**GNF 20 VB**

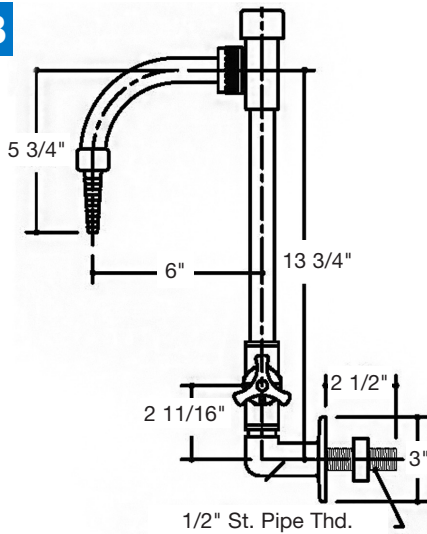

**Recommended Specifications**

Welded Assembly Wall mounted Laboratory Faucet with integral vacuum breaker manufactured from virgin unpigmented resin. Polypropylene per ASTM D 4101 PVDF per ASTM D 3222.

**GNF 40 VB**

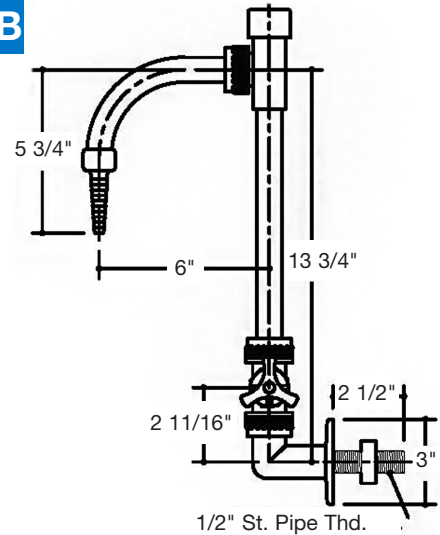

**Recommended Specifications**

Threaded Assembly Wall mounted Laboratory Faucet with integral vacuum breaker manufactured from virgin unpigmented resin. Polypropylene per ASTM D 4101 PVDF per ASTM D 3222.

## GNF 10 STD

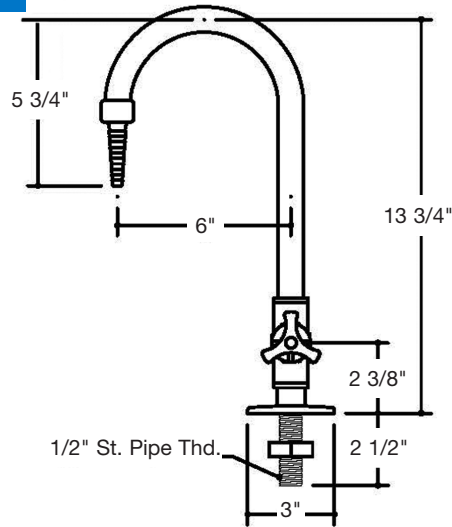

### Recommended Specifications

Welded Assembly Deck mounted Laboratory Faucet manufactured from virgin unpigmented resin. Polypropylene per ASTM D 4101 PVDF per ASTM D 3222.

## GNF 30 STD

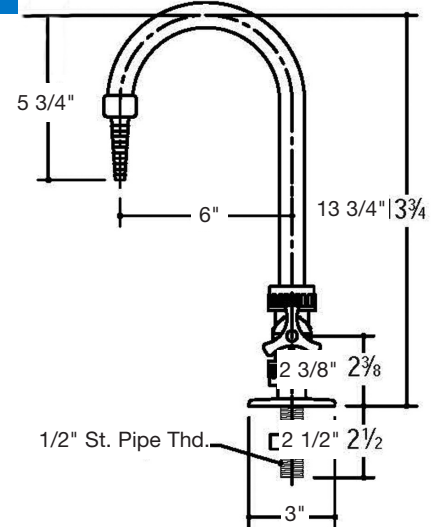

### Recommended Specifications

Threaded Assembly Deck mounted Laboratory Faucet manufactured from virgin unpigmented resin. Polypropylene per ASTM D 4101 PVDF per ASTM D 3222.

## GNF 20 STD

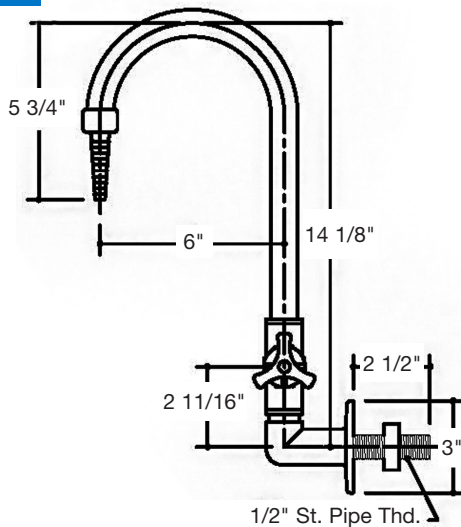

### Recommended Specifications

Welded Assembly Wall mounted Laboratory Faucet manufactured from virgin unpigmented resin. Polypropylene per ASTM D 4101 PVDF per ASTM D 3222.

## GNF 40 STD

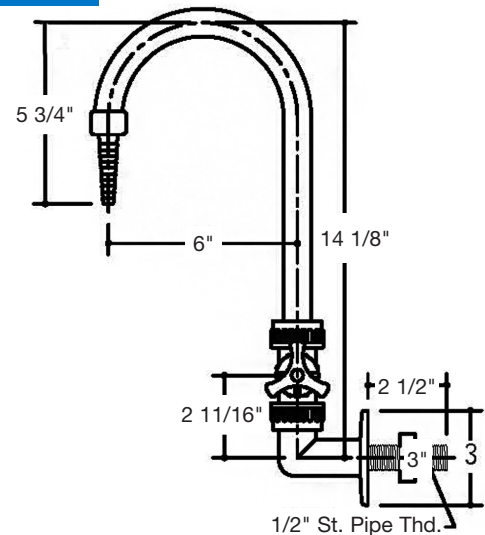

### Recommended Specifications

Threaded Assembly Wall mounted Laboratory Faucet manufactured from virgin unpigmented resin. Polypropylene per ASTM D 4101 PVDF per ASTM D 3222.

### Recirculating Faucet

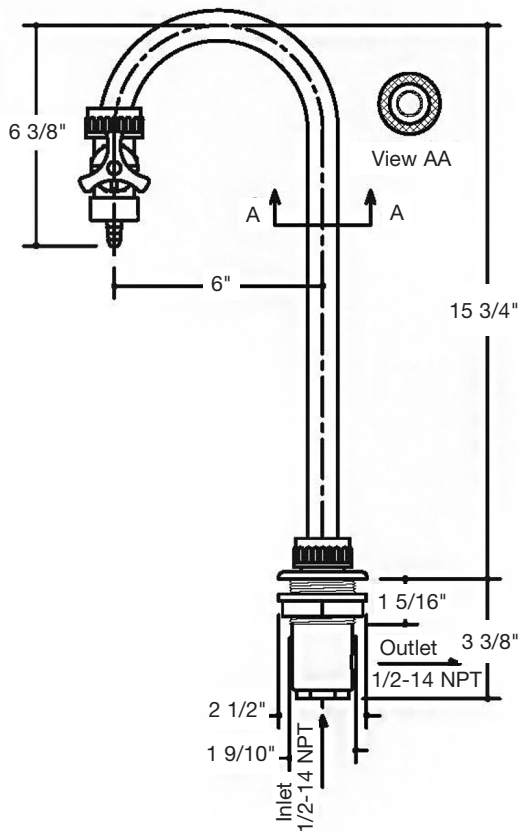

### Recirculating Faucet PVDF

Deck Mounted Recirculating Laboratory Faucet manufactured from virgin unpigmented PVDF resin per ASTM D 3222. Inlet and Outlet to be 1/2" female pipe thread, and molded into base. Unit to be activated by needle valve of same resin, mounted at point of release of fluid.

### Recirculating Faucet PP

Deck Mounted Recirculating Laboratory Faucet manufactured from virgin unpigmented Type I Homopolymer Polypropylene per resin ASTM D 4101. Inlet and Outlet to be 1/2" female pipe thread, and molded into base. Unit to be activated by needle valve of same resin, mounted at point of release of fluid.

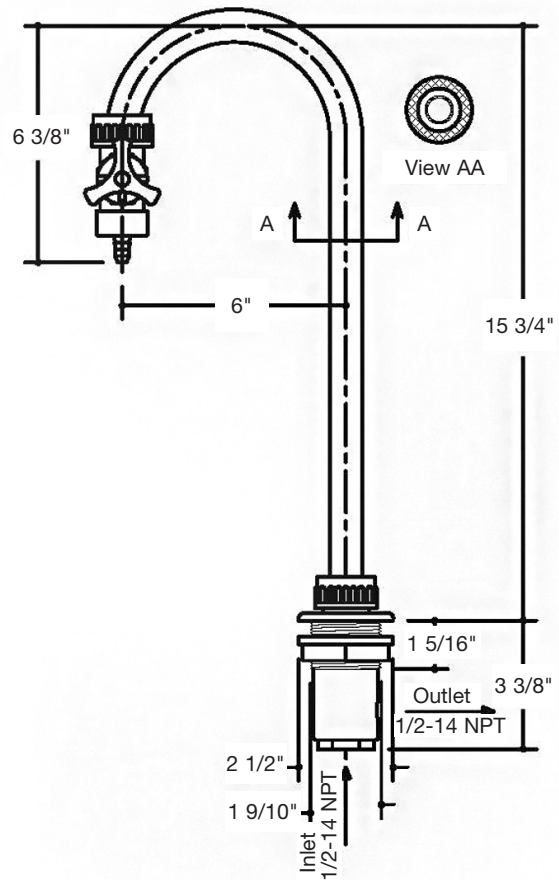

## Flow of Recirculating Faucet

Water runs through inlet pipe, up the inner tube of the faucet and into the needle valve. If water is not diverted through the hose barb and out the faucet, it will run back out the outside of the inner faucet tube and out the outlet pipe on the bottom side of the faucet.

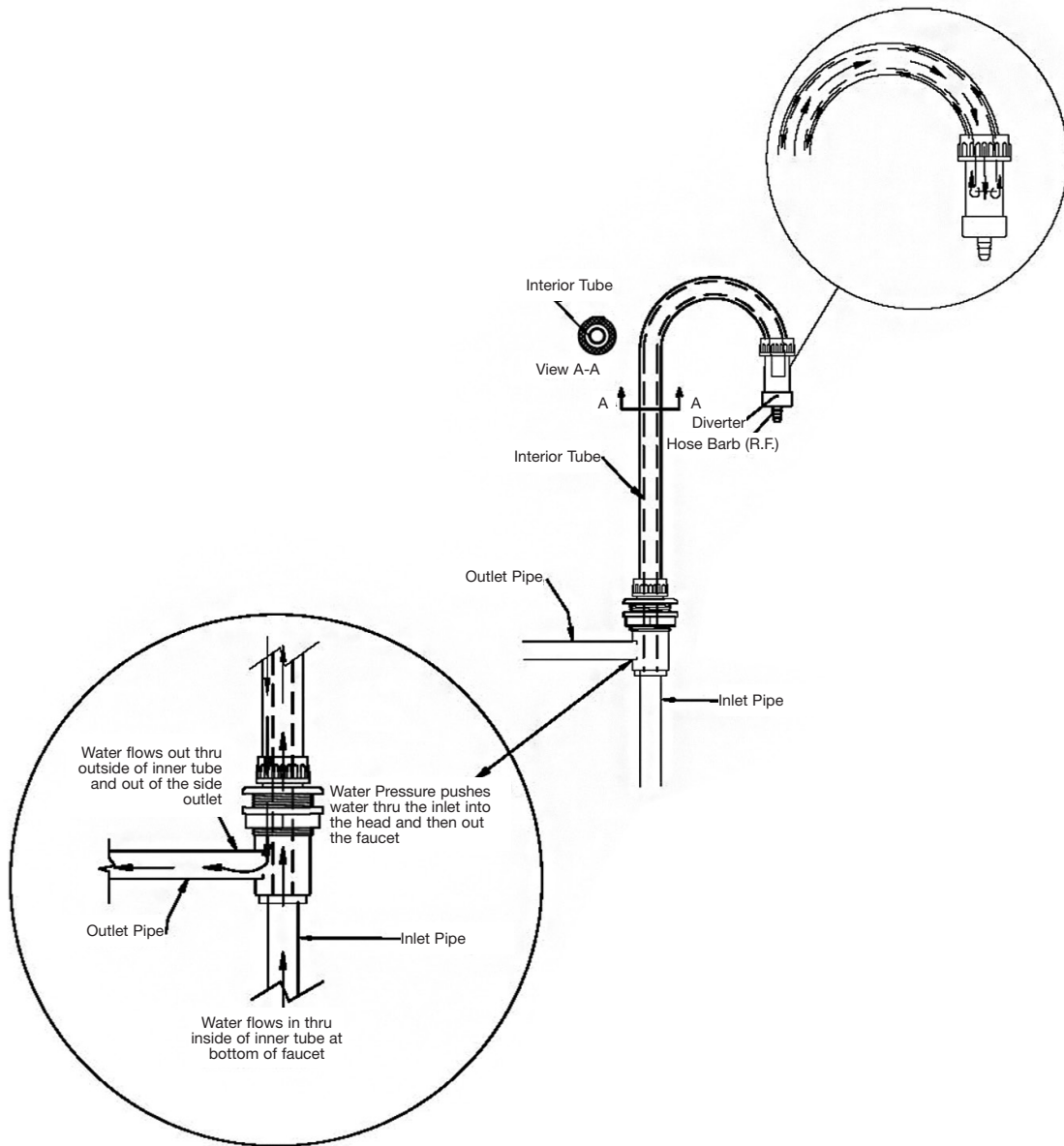

## Leachable Testing of Orion Whiteline High Purity Polypropylene Piping into High Purity Water Conducted by Mead CompuChem Company

Orion's Whiteline polypropylene piping is manufactured from high purity, unpigmented polypropylene homopolymer resin. It is used for transportation of high purity liquids such as distilled water and up to 18 megohm deionized water.

To establish the level of purity of Whiteline piping, testing was performed by Mead CompuChem Company to determine pollutant concentrations. This testing included chromatograms, mass spectra, calibration and quality control data for the organics.

It should be noted that the only significant contaminants include methylene chloride and toluene. The testing facility confirmed through independent control sample testing that the presence of methylene chloride was the result of laboratory contamination and that the presence of toluene was likely the result of contamination from the paint markings on the outside of the piping.

### Results:

With the exception of the two laboratory contaminants listed above, the levels of leachables tested were below the limits of detection for the instruments used. These test results show that Orion Whiteline piping is of very high purity and is the material of choice for almost any high purity liquid application. Detailed test results are shown on the attached pages.

## Orion Whiteline Unpigmented Polypropylene Leachables Testing Report

Sample Identifier: ASTM-2146-SC4-40-1/2

CompuChem Sample Number: 7269

Number	Volatile Organ	Concentration (UG/L)	Detection Limit (UG/L)
1V.	Acrolein	BDL	100
2V.	Acrylonitrile	BDL	100
3V.	Benzene	BDL	10
4V.	BIS (Chloromethyl) Ether	BDL	10
5V.	Bromoform	BDL	10
6V.	Carbon Tetrachloride	BDL	10
7V.	Chlorobenzene	BDL	10
8V.	Chlorodibromomethane	BDL	10
9V.	Chloroethane	BDL	10
10V.	2-Chloroethylvinyl Ether	BDL	13
11V.	Chloroform	BDL	10
12V.	Dichlorobromomethane	BDL	10
13V.	Dichlorodifluoromethane	BDL	10
14V.	1, 1-Dichloroethane	BDL	10
15V.	1, 2-Dichloroethane	BDL	10
16V.	1, 1-Dichloroethylene	BDL	10
17V.	1, 2-Dichloropropylene	BDL	10
18V.	1, 3-Dichloropropylene	BDL	10
19V.	Ethylbenzene	BDL	10
20V.	Methyle Bromide	BDL	10
21V.	Methyle Chloride	BDL	10
22V.	Methylene Chloride	11*	10
23V.	1, 1, 2, 2-Tetrachloroethane	BDL	10
24V.	Tetrachloroethylene	BDL	10
25V.	Toluene	82*	10
26V.	1, 2-Trans-D1Chloroethylene	BDL	10
27V.	1, 1, 1-Trichloroethane	BDL	10
28V.	1, 1, 2-Trichloroethane	BDL	10
29V.	Trichloroethylene	BDL	10
30V.	Trichlorofluoromethane	BDL	10
31V.	Vinyl Chloride	BDL	10
<b>Acid Extractable Organics</b>			
1A.	2-Chlorophenol	BDL	25
2A.	2, 4-Dichlorophenol	BDL	25
3A.	2, 4-Dimethylphenol	BDL	25
4A.	4, 6-Dinitro-O-Cresol	BDL	250
5A.	2, 4-Dinitrophenol	BDL	250
6A.	2-Nitrophenol	BDL	25
7A.	4-Nitrophenol	BDL	25
8A.	P-Chloro-M-Cresol	BDL	25
9A.	Pentachlorophenol	BDL	25
10A.	Phenol	BDL	25
11A.	1, 4, 6-Trichlorophenol	BDL	25

\*BDL = Below Detection Limit

## Leachables

Number	Base-NeutralExtractable Org	Concentration (UG/L)	Detection Limit (UG/L)
1B.	Acenaphthene	BDL	100
2B.	Acenaphthylene	BDL	100
3B.	Anthracene	BDL	10
4B.	Benzidine	BDL	10
5B.	Benzo (A) Anthracene	BDL	10
6B.	Benzo (A) Pyrene	BDL	10
7B.	3, 4-Benzofluoranthene	BDL	10
8B.	Benzo (GHI) Perylene	BDL	25
9B.	Benzo (K) Fluoranthene	BDL	10
10B.	BIS (2-Chloroethoxy) Methane	BDL	13
11B.	BIS (2-Chloroethyl) Ether	BDL	10
12B.	BIS (2-Chloroisopropyl) Ether	BDL	10
13B.	BIS (2-Ethylhexyl) Phthalate	BDL	10
14B.	4-Bromophenyl Phenyl Ether	BDL	10
15B.	Butyl Benzyl Phthalate	BDL	10
16B.	2-Chloronaphthalene	BDL	10
17B.	4-Chlorophenyl Phenyl Ether	BDL	10
18B.	Chrysene	BDL	10
19B.	Dibenzo (A, H) Anthracene	BDL	25
20B.	1, 2-Dichlorobenzene	BDL	10
21B.	1, 3-Dichlorobenzene	BDL	10
22B.	1, 4-Dichlorobenzene	BDL	10
23B.	3, 3-Dichlorobenzidine	BDL	10
24B.	Diethyl Phthalate	BDL	10
25B.	Dimethyl Phthalate	BDL	10
26B.	DI-N-Butyl Phthalate	BDL	10
27B.	2, 4-Dinitrotoluene	BDL	10
28B.	2, 6-Dinitrotoluene	BDL	10
29B.	Di-N-Octyl Phthalate	BDL	10
30B.	1, 2-Diphenylhydrazine	BDL	10
31B.	Fluoranthene	BDL	10
32B.	Fluorene	BDL	10
33B.	Hexachlorobenzene	BDL	10
34B.	Hexachlorobutadiene	BDL	10
35B.	Hexachlorocyclopentadiene	BDL	10
36B.	Hexachloroethane	BDL	10
37B.	Indeno (1, 2, 3-CD) Pyrene	BDL	25
38B.	Isophorone	BDL	10
39B.	Naphthalene	BDL	10
40B.	Nitrobenzene	BDL	10
41B.	N-Nitrosodimethylamine	BDL	10
42B.	N-Nitrosodi-N-Propylamine	BDL	10
43B.	N-Nitrosodiphenylamine	BDL	10
44B.	Phenanthrene	BDL	10
45B.	Pyrene	BDL	10
46B.	1, 2, 4-Trichlorobenzene	BDL	10
Limit			*BDL = Below Detection

## Leachables

Number	Pesticides/PCB-S	Concentration (UG/L)	(UG/L)
1P.	Aldrin	BDL	10
2P.	Alpha-BHC	BDL	10
3P.	Beta-BHC	BDL	10
4P.	Gamma-BHC	BDL	10
5P.	Delta-BHC	BDL	10
6P.	Chlordane	BDL	10
7P.	4, 4-DDT	BDL	10
8P.	4, 4-DDE	BDL	10
9P.	4, 4-DDD	BDL	10
10P.	Dieldrin	BDL	13
11P.	Alpha-Endosulfan	BDL	10
12P.	Beta-Endosulfan	BDL	10
13P.	Endosulfan Sulfate	BDL	10
14P.	Endrin	BDL	10
15P.	Endrin Aldehyde	BDL	10
16P.	Heptachlor	BDL	10
17P.	Heptachlor Epoxide	BDL	10
18P.	PCB-1242	BDL	10
19P.	PCB-1254	BDL	10
20P.	PCB-1221	BDL	10
21P.	PCB-1232	BDL	10
22P.	PCB-1248	BDL	10
23P.	PCB-1260	BDL	10
24P.	PCB-1016	BDL	10
25P.	Toxaphene	BDL	10
Limit			*BDL = Below Detection

### NOTICE

According to the testing laboratory, the presence of methylene chloride is likely the result of laboratory contamination and toluene is likely the result of contamination from the paint markings on the outside of the pipe.

## Non-Flame Retardant PP

Property	Unit	Value	Test Method
Nominal Melt Flow (at 230° C / 2.16 kg)	g/10 Min.	0.75	ASTM D1238
Density (at 73°F (23°C))	g/cm <sup>3</sup>	0.901	ASTM D792
Tensile Strength at Yield	psi	3,400	ASTM D638
Elongation at Yield	%	15	ASTM D638
Modulus of Elasticity	psi	150,000	ASTM D790A
Izod Impact, notched at 73°F (23°C)- 1/8" bar	Ft-Lb/In	13	ASTM D256
Rockwell Hardness	R scale	77	ASTM D785
Melting Point	°F	324	Aristech
	°C	162	Aristech
Specific Gravity		.905	ASTM D792
Water Absorption 24 hrs @ 73°F (23°C))	%	.02	ASTM D570
Polypropylene Material	Cell Class	PP 0348	ASTM D4101

## PVDF (740)

Property	Unit	Value	Test Method
Specific Gravity		1.76	ASTM D-792
Water Absorption 24 Hrs.@ 73°F (23°C)	%	.03	ASTM D-570
Tensile Strength psi @ 73°F (23°C)	psi	6,000	ASTM D-638
Modulus of Elasticity @ 73°F (23°C)	psi	210,000	ASTM D-638
Flexural Modulus psi	psi	9,700	ASTM D-790
Izod Impact Strength @ 73°F (23°C) (Notched)	Ft-Lb/In	3.8	ASTM D-256
Hardness	Shore D	78	ASTM D-2240
Melting Point	°F	330	ASTM D-3418
Coefficient of Thermal Expansion	In/In°F x 10 <sup>-5</sup>	7.4	ASTM D-696
Thermal Conductivity	BTU-In/HR/Sq.Ft/°F	1.18	ASTM D-433
Heat Distortion Temp. @ 66psi	psi	251	ASTM D-648
Heat Distortion Temp. @ 264 psi	psi	221	ASTM D-648
Limiting Oxygen Index (%)	%	44	ASTM D-2836
Underwriter's Lab Rating (sub. 94)		V-0	UL. 94
PVDF Material	Class	Type I, Grade II	ASTM D3222
Corrosive Drainage Waste System		Complies	ASTM F1673

## PVDF (1000 HD)

Property	Unit	Value	Test Method
Specific Gravity		1.76	ASTM D-792
Water Absorption 24 Hrs.@ 73°F (23°C)	%	.03	ASTM D-570
Tensile Strength psi @ 73°F (23°C)	psi	6,000	ASTM D-638
Modulus of Elasticity @ 73°F (23°C)	psi	210,000	ASTM D-638
Flexural Modulus psi	psi	9,700	ASTM D-790
Izod Impact Strength @ 73°F (23° (Notched)	Ft-Lb/In	3.8	ASTM D-256
Hardness	Shore D	78	ASTM D-2240
Melting Point	°F	330	ASTM D-3418
Coefficient of Thermal Expansion	In/In°F x 10 <sup>-5</sup>	7.4	ASTM D-696
Thermal Conductivity	BTU-In/HR/Sq.Ft/°F	1.18	ASTM D-433
Heat Distortion Temp. @ 66psi	psi	251	ASTM D-648
Heat Distortion Temp. @ 264 psi	psi	221	ASTM D-648
Limiting Oxygen Index (%)	%	44	ASTM D-2836
Underwriter's Lab Rating (sub. 94)		V-0	UL. 94
PVDF Material	Class	Type I, Grade II	ASTM D3222
Corrosive Drainage Waste System		Complies	ASTM F1673
Flame Spread		0-5	ASTM E-84
Smoke Developed		35	ASTM E-84

## Recommended Pipe Support Schedule for Above Ground Installations

- Data based on Orion pipe supported on uniform centers; carrying liquids having specific gravities up to 1.30 without major load concentration
- Recommendations are for uninsulated lines. If pipe is insulated, spans should be reduced by 35% to accommodate weight of insulation.
- Never support pipe in tight clamps; lines must be free to move axially.
- Do not use compressed air or other compressed gases for testing of or use in any Orion system. Do not use compressed air or other compressed gases for testing of or use in any Orion system.

### Polypropylene\* High Purity Pipe (Maximum Span, Feet)

Schedule 40 -Temperature, °F (°C)

Pipe Size	70 (21)	120 (49)	150 (65)
1/2"	4	3	continuous
3/4"	4	3	continuous
1"	4.5	3	continuous
1 1/2"	5	3.5	continuous
2"	5	3.5	2
3"	6	3.5	2.5
4"	6	4.5	3

Schedule 80 -Temperature, °F (°C)

Pipe Size	70 (21)	120 (49)	150 (65)
1/2"	5	3.5	continuous
3/4"	5	3.5	continuous
1"	5.5	4	continuous
1 1/2"	5.5	4	2.5
2"	6	4.5	2.5
3"	7	5	3
4"	7.5	5	3.5

\*Whiteline or Standardline

### PVDF High Purity Pipe (Maximum Span, Feet)

Schedule 40 -Temperature, °F (°C)

Pipe Size	70 (21)	120 (49)	150 (65)
1/2"	4	3	continuous
3/4"	4.5	3	continuous
1"	4.5	3.5	continuous
1 1/2"	5.5	4	continuous
2"	5.75	4	2
3"	6.5	4.5	2.5
4"	7.5	5	3

Schedule 80 - Temperature, °F (°C)

Pipe Size	70 (21)	120 (49)	150 (65)
1/2"	5	3.5	continuous
3/4"	5.5	3.5	continuous
1"	5.5	4	continuous
1 1/2"	6	4	2.5
2"	6.5	4.5	2.5
3"	7	5	3
4"	8	5	3.5

## Fittings Specifications

Socket Fusion - Polypropylene fittings are manufactured to schedule 80 wall thickness from virgin unpigmented Type I homopolymer polypropylene meeting ASTM D4101 using no antioxidants or pigments. All socket fusion fittings meet or exceed ASTM D2657 standards. All Type I homopolymer (Whiteline) fittings are bagged. All Type II copolymer (Standardline) fittings are packaged.

PVDF fittings are manufactured from virgin unpigmented PVDF resin meeting ASTM D3222. The fittings meet or exceed ASTM D2657 standards. Each fitting is bagged.

Valves - All Orion valves are manufactured from virgin unpigmented polypropylene or PDVF to be fully compatible with the Orion system. All valves test at 150 psi at 73°F (23°C). Each valve is bagged.

Pressure ratings are based on water service at 73°F (23°C) with fused joints. Threaded connections are not recommended for pressure systems. Depending on actual service conditions, derating factors may apply. See Table.

Polypropylene High Purity systems contain no ultraviolet inhibitor and must be protected from direct sunlight or ultraviolet rays.

## PP Pressure Rating Correction Chart

Temperature °F (°C)	Correction Factor
73 (23)	1.00
80 (27)	.93
90 (32)	.83
100 (38)	.74
110 (43)	.66
120 (49)	.58
130 (54)	.51
140 (60)	.40
150 (66)	.38
160 (71)	.35
180 (82)	.23
200 (93)	.14
210 (99)	.10

## PVDF Pressure Rating Correction Chart

Temperature °F (°C)	Correction Factor
73 (23)	1.00
80 (27)	.93
90 (32)	.83
100 (38)	.74
110 (43)	.66
120 (49)	.58
130 (54)	.51
140 (60)	.40
150 (66)	.38
160 (71)	.35
180 (82)	.23
200 (93)	.14
210 (99)	.10

## Testing Procedures for Orion Socket Fusion / Whiteline

Hydrostatic testing of Orion's Socket Fusion pressure systems can be performed one hour after the final joint has been completed. The testing procedure detailed below should be strictly adhered to.

1. Fully inspect the installed piping for evidence of mechanical abuse and suspect joints.
2. Split the system into convenient test sections, not exceeding 1000 ft. The piping should be capped off at the end of the pipe section to be tested.
3. Slowly fill the pipe section with water, taking care to remove all trapped air in the piping. Use air release valves in any high spots in the system. Do not pressurize at this stage. Do not air test, test hydrostatically only.
4. Leave the pipe for at least one hour, to allow an equilibrium temperature to be achieved.
5. Visually check the system for leaks. If clear, check for and remove any remaining air from the system.
6. Pressurize the system to 1-1/2 times the working pressure - not to exceed a maximum of 150 psi by means of a low pressure hand pump.
7. Leave the line at test pressure for a period of up to 1 hour, during which time the pressure gauge reading should not change.
8. If there is a significant drop in pressure, or extended times are required to achieve the desired pressure, either joint leakage has occurred or air is still trapped in the line. In this event, inspect for joint leaks. If none are found, check for trapped air - this must be removed prior to continuing the test.
9. If joints are found to be leaking, the system must be fully drained and the joints repaired or replaced. To repair a Socket Fusion joint, either backwelding can be performed (see our published backwelding procedures) or the joint can be cut out and a new one installed in accordance with our published installation instructions.
10. Once joints are repaired or replaced, repeat the pressure test following the procedure described above.

### **⚠ WARNING**

Under no circumstances should plastic piping be tested with air or any type of compressed gases. This type of test method could result in system damage and personal injury.

Plastic piping should be hydrostatically tested **ONLY**.

Typical plastic pipe standards state that the pressure rating of piping is based on it's hydrostatic design stress and the following formula:

$$SDR = \frac{\text{Pipe O.D.}}{\text{Min. Wall Thickness}} \quad P = \frac{2 \times S}{SDR-1}$$

**P** = Internal Pipe Pressure Rating

**S** = Hydrostatic Design Stress

S = 800 psi for PP

S-2300 psi for PVDF

**SDR** = Standard Dimension Ration of Pipe

The charts below have been developed based on the above formula. It should be noted that these charts indicate the maximum non-shock pressure ratings and do not take joining methods or poor installation practices into account. Joint strength is limited by flanges, valves, joining techniques, stress and other limiting factors.

## Maximum Operating Pressures (PSI) at 73°F (23°C)

Pipe Size	Polypropylene	PVDF
-	Sch 80	Sch 80
1/2"	340	975
3/4"	275	790
1"	250	725
1 1/2"	190	540
2"	165	465
3"	150	430
4"	130	370

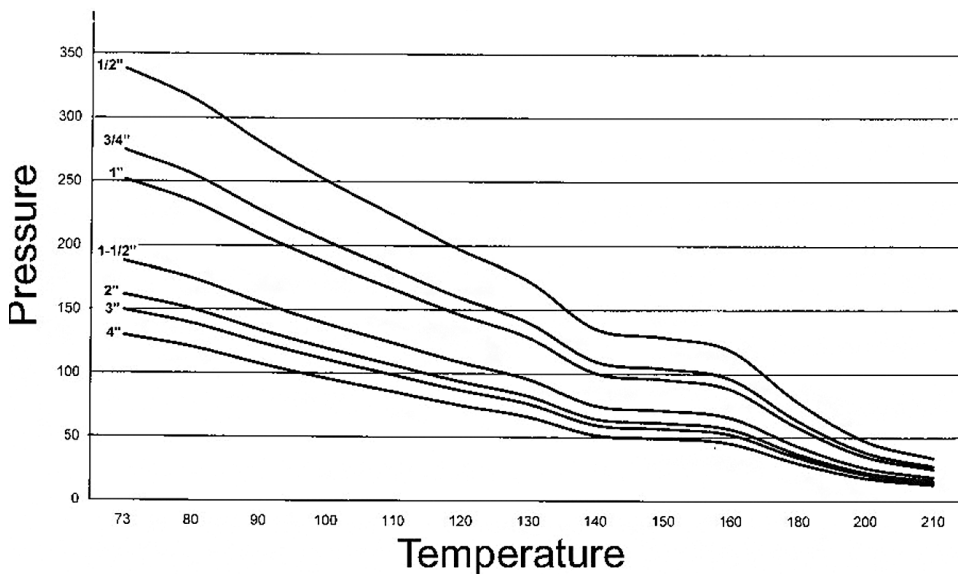

**PVDF Pipe Pressure Tables Sch 80**

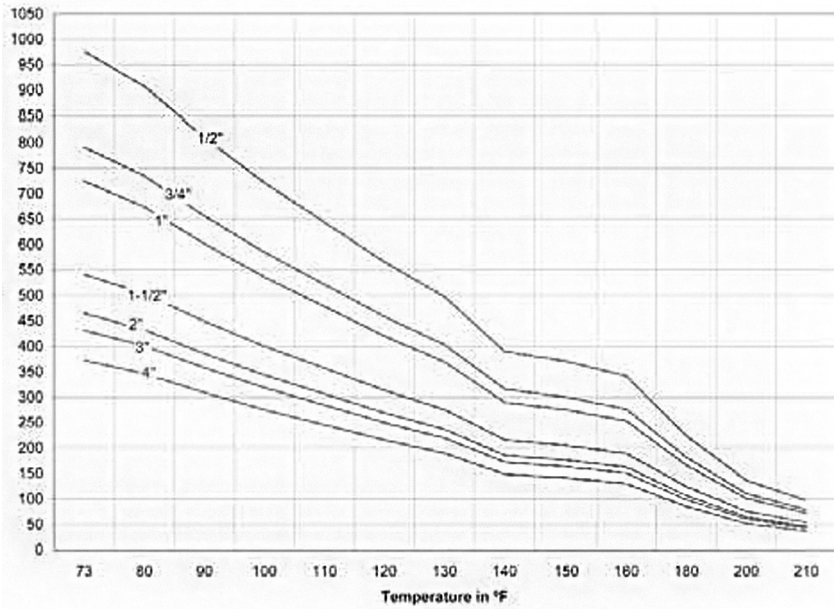

Operating Temperature	PP Max. PSI	PVDF Max. PSI
73°F (23°C)	150	150
80°F (27°C)	140	145
90° (32°C)	125	130
100° (38°C)	110	120
120° (49°C)	87	105
140° (60°C)	60	87
160° (71°C)	53	74
180° (82°C)	35	63
200° (93°C)	21	54
220° (104°C)	N/A	45
240° (116°C)	N/A	38
280° (138°C)	N/A	27

## Friction Loss in Fittings

Equivalent Length of Pipe, Feet											
Size Fittings	1/2"	3/4"	1"	1 1/2"	2"	3"	4"	6"	8"	10"	12"
<b>Type Fittings</b>											
90° Standard Elbow	1.6	2.1	2.6	4.0	5.5	7.7	10.1	15.2	20.0	25.1	29.8
45° Standard Elbow	0.8	1.1	1.4	2.1	2.8	4.1	5.4	8.1	10.6	13.4	15.9
90° Long Radius Elbow	1.0	1.4	1.7	2.7	4.3	6.3	8.3	12.5	16.5	20.7	24.7
90° Street Elbow	2.6	3.4	4.4	6.7	8.6	12.8	16.8	25.3	33.3	41.8	49.7
45° Street Elbow	1.3	1.8	2.3	3.0	4.5	6.6	8.7	13.1	17.3	21.7	25.9
Square Corner Elbow	3.0	3.9	5.0	7.6	9.8	14.6	19.1	28.8	37.9	47.6	56.7
Standard with Flow thru run	1.0	1.4	1.7	2.7	4.3	6.3	8.3	12.5	16.5	20.7	24.7
Tee with flow thru Branch	4.0	5.1	6.0	8.1	12.0	16.3	22.1	32.2	39.9	50.1	59.7

## Friction Loss in Fitting Valves

As an aid, liquid sizing constants Cv values are shown for valves. These values are defined as the flow rate through the valve required to produce a pressure drop of 1 psi. To determine the pressure drop for a given GPM, the following formula may be used:

$$\Delta P = (G^2) (SG) / Cv^2$$

Where:

AP = Pressure Drop

G = Flow in GPM

SG = Specific Gravity of the liquid (water = 1.0)

Cv = Flow Coefficient

Example: Find the pressure drop across a 1/2" Ball valve with a water flow rate of 10 GPM.

$$\Delta P = (G^2) (SG) / Cv^2 \quad P = (10) (10) (1) / (22) (22) \quad P = .206$$

Size	Cv Ball Valve (TU)	Cv Diaphragm Valve
1/2"	22	6.5
3/4"	55	9.5
1"	112	12.3
1 1/2"	285	29.2
2"	540	53.7

**Friction Loss in Fittings**

**Carrying Capacity & Friction Loss for Schedule 80 Thermoplastic Pipe**

GPM	1/2"		3/4"			1"			1 1/2"			2"			3"			
	Velocity Feet per Second	Friction Head Feet	Friction Loss lbs per Sq. In.	Velocity Feet per Second	Friction Head Feet	Friction Loss lbs per Sq. In.	Velocity Feet per Second	Friction Head Feet	Friction Loss lbs per Sq. In.	Velocity Feet per Second	Friction Head Feet	Friction Loss lbs per Sq. In.	Velocity Feet per Second	Friction Head Feet	Friction Loss lbs per Sq. In.	Velocity Feet per Second	Friction Head Feet	Friction Loss lbs per Sq. In.
1	1.48	4.02	1.74	0.74	0.86	0.37												
2	2.95	8.03	3.48	1.57	1.72	0.74	0.94	0.88	0.38	0.38	0.10	0.041						
5	7.39	45.23	19.59	3.92	9.67	4.19	2.34	2.75	1.19	0.94	0.30	0.126	0.56	0.10	0.04	0.25	0.02	0.009
7	10.34	83.07	35.97	5.49	17.76	7.69	3.28	5.04	2.19	1.32	0.55	0.24	0.78	0.15	0.065	0.35	0.028	0.012
10				7.84	33.84	14.65	4.68	9.61	4.16	1.88	1.04	0.45	1.12	0.29	0.13	0.50	0.04	0.017
15		4"		11.76	71.70	31.05	7.01	20.36	8.82	2.81	2.20	0.95	1.68	0.62	0.27	0.75	0.09	0.039
20	0.57	0.04	0.017				9.35	34.68	15.02	3.75	3.75	1.62	2.23	1.06	0.46	1.00	0.15	0.065
25	0.72	0.06	0.026				11.69	52.43	22.70	4.69	5.67	2.46	2.79	1.60	0.69	1.25	0.22	0.095
30	0.86	0.08	0.035				14.03	73.48	31.82	5.63	7.95	3.44	3.35	2.25	0.97	1.49	0.31	0.13
35	1.00	0.11	0.048							6.57	10.58	4.58	3.91	2.99	1.29	1.74	0.42	0.18
40	1.15	0.14	0.061							7.50	13.55	5.87	4.47	3.83	1.66	1.99	0.54	0.23
45	1.29	0.17	0.074		6"					8.44	16.85	7.30	5.03	4.76	2.07	2.24	0.67	0.29
50	1.43	0.21	0.091	0.63	0.03	0.013				9.38	20.48	8.87	5.58	5.79	2.51	2.49	0.81	0.35
60	1.72	0.30	0.13	0.75	0.04	0.017				11.26	28.70	12.43	6.70	8.12	3.52	2.99	1.14	0.49
70	2.01	0.39	0.17	0.88	0.05	0.022							7.82	10.80	4.68	3.49	1.51	0.65
75	2.15	0.45	0.19	0.94	0.06	0.026							8.38	12.27	5.31	3.74	1.72	0.74
80	2.29	0.50	0.22	1.00	0.07	0.030		8"					8.93	13.83	5.99	3.99	1.94	0.84
90	2.58	0.63	0.27	1.13	0.08	0.035							10.05	17.20	7.45	4.48	2.41	1.04
100	2.87	0.76	0.33	1.25	0.10	0.043							11.17	20.90	9.05	4.98	2.93	1.27
125	3.59	1.16	0.50	1.57	0.16	0.068	0.90	0.045	0.019							6.23	4.43	1.92
150	4.30	1.61	0.70	1.88	0.22	0.095	1.07	0.05	0.022		10"					7.47	6.20	2.68
175	5.02	2.15	0.93	2.20	0.29	0.12	1.25	0.75	0.033							8.72	8.26	3.58
200	5.73	2.75	1.19	2.51	0.37	0.016	1.43	0.09	0.039	0.90	0.036	0.015		12"		9.97	10.57	4.58
250	7.16	4.16	1.81	3.14	0.56	0.24	1.79	0.14	0.610	1.14	0.045	0.02				12.46	16.00	6.93
300	8.60	5.83	2.52	3.76	0.78	0.34	2.14	0.20	0.087	1.36	0.07	0.03						
350	10.03	7.76	3.36	4.39	1.04	0.45	2.50	0.27	0.12	1.59	0.085	0.037	1.12	0.037	0.016			
400	11.47	9.93	4.30	5.02	1.33	0.58	2.86	0.34	0.15	1.81	0.11	0.048	1.28	0.05	0.022			
450				5.64	1.65	0.71	3.21	0.42	0.18	2.04	0.14	0.061	1.44	0.06	0.026			
500				6.27	2.00	0.87	3.57	0.51	0.22	2.27	0.17	0.074	1.60	0.07	0.030			
750				9.40	4.25	1.84	5.36	1.08	0.47	3.40	0.36	0.16	2.40	0.15	0.065			

## Friction Loss in Fittings

Carrying Capacity & Friction Loss for Schedule 80 Thermoplastic Pipe

GPM	Velocity Feet per Second	Friction Head Feet	Friction Loss lbs per Sq. In.	3/4"			1"			1 1/2"			2"			3"		
				Velocity Feet per Second	Friction Head Feet	Friction Loss lbs per Sq. In.	Velocity Feet per Second	Friction Head Feet	Friction Loss lbs per Sq. In.	Velocity Feet per Second	Friction Head Feet	Friction Loss lbs per Sq. In.	Velocity Feet per Second	Friction Head Feet	Friction Loss lbs per Sq. In.	Velocity Feet per Second	Friction Head Feet	Friction Loss lbs per Sq. In.
1000				12.54	7.23	3.13	7.14	1.84	0.80	4.54	0.61	0.26	3.20	0.26	0.11			
1250							8.93	2.78	1.20	5.67	0.92	0.40	4.01	0.40	0.17			
1500							10.71	3.89	1.68	6.80	1.29	0.56	4.81	0.55	0.24			
2000										9.07	2.19	0.95	6.41	0.94	0.41			
2500										11.34	3.33	1.44	8.01	1.42	0.62			
3000													9.61	1.99	0.86			
3500													11.21	2.65	1.15			
4000													12.82	3.41	1.48			

## Socket Fusion Assembly

A socket fusion tool kit, including heat tool and various sizes of heads, is available from Orion (Sold Separately).

**Note:**

- Make all field cuts of pipe square and true using a pipe cutter for designed plastic pipe.
- Make certain heads are installed properly on heat tool.
- Heads are marked "M" and "F", indicating male and female.
- Bevel the leading edge of each pipe section with a 1/8"45 degree chamfer. This will minimize the amount of bead on the inside of the fitting when fused.

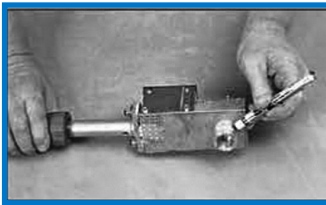

**Step 1.**

Check the heads for proper temperature (482°F - 520°F or (250°C - 270°C). If necessary, adjust the thermostat dial so that the 488°F (253°C) Tempil stick burns, but the 525°F (274°C) does not.

**Note:** The newest Orion fusion tools may have a temperature dial in degrees celsius which has a maximum temperature of 300° C. If this is the case, see temperature conversion chart below. Heat tools are factory set, however settings can vary due to factors such as weather, current variances, cord lengths, generators, etc. These variables should be checked on site. To increase tool temperature, turn dial "in" (clockwise). To decrease, turn screw "out" (counterclockwise).



**Step 2.**

Measure depth of fitting. Subtract 1/16".



**Step 3.**

Transfer measurement to pipe. Mark pipe with measurement obtained in Step 2.



**Step 4.**

Insert fitting on the male side of the heat tool. Then insert pipe on the female side. Do not insert past the mark on the pipe.

**Step 5.**

Keep pipe and fitting absolutely straight on heat tool. Use the chart below to determine how long to leave the pipe and fittings on the heater bushings. It should be noted that pipe and fittings will normally have a slight interference with the fusion tools. However, if the pipe and/or fittings do not fit tightly on the heater bushing, the heating time should be started when the components have swelled to just contact the surface of the bushing.



**Step 6.**

Hold joint under pressure for 15 seconds to allow surfaces to fuse. Do not stress joint until fully cooled. Clean any melted material from heater bushing using a cotton rag. Do not use abrasive materials to clean the heater bushings.

Confirm the heater bushings are the correct temperature before fusing next joint.

The following chart shows the approximate time that the pipe and fitting should be held on the heater bushings. These times are a guideline only. It may be necessary to increase or decrease times to obtain the correct melt conditions.

Material	Fusion Times				
	1/2"	3/4"	1"	1 1/2"	2"
PP	7-10 Sec.	7-10 Sec.	10-15 Sec.	10-15 Sec.	15-20 Sec.
PVDF	10-15 Sec.	13-18 Sec.	14-20 Sec.	15-20 Sec.	20-25 Sec.

°F	°C
122	50
212	100
300	150
392	200
482	250
520	270
572	300

Temperature Conversion Factors
°F = Degrees in Fahrenheit
°C = Degrees in Celsius (Centigrade)

Temperature Conversion Factors
$^{\circ}\text{F} = (^{\circ}\text{C} \times 1.8) + 32$
$^{\circ}\text{C} = (^{\circ}\text{F} - 32) \times .555$

**⚠ WARNING**

Do not test any Orion Piping System with compressed air or gases. Test Hydrostatically only.

## Valve Welding Instructions

Ball Valves must be dis-assembled before the welding process. Remove union nuts and socket ends from the body. Slide the union nut over the pipe and weld the socket ends to the pipe. Re-assemble the valve in line. Care must be taken so that the o-rings are properly seated when re-assembling the union nuts. This procedure will eliminate the possibility of heat from the socket fusion tool distorting the ball and seats.

**⚠ WARNING**

Valve must be in closed position before tightening union nuts.

1. Union Nut
2. Valve Body
3. Locking Ring
4. Carrier
5. Handle
6. Stem
7. Stem O-ring
8. Ball
10. Carrier O-ring
11. Face O-ring
12. Socket end (can be supplied as threaded)

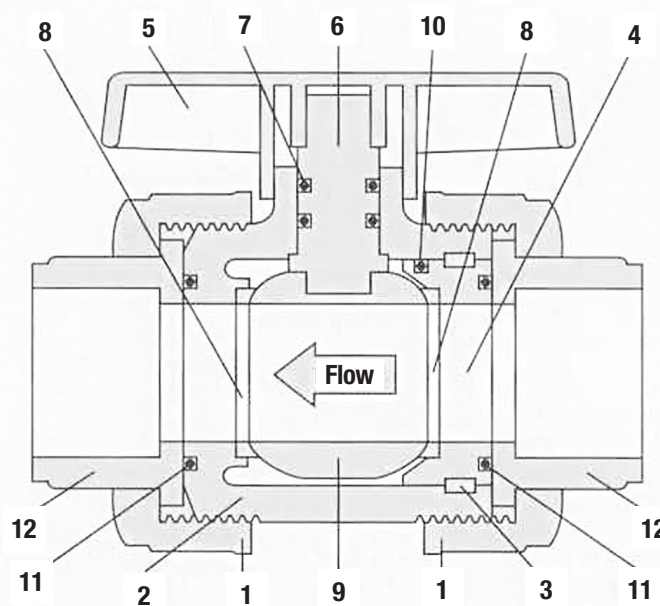

## Installation

- A. Turn valve to closed position.
- B. Install assembled valve body (2) in line, being careful not to dis-lodge face O-rings (11).
- C. Hand tighten Union nuts (1).
- D. Tighten an additional 1/2 turn maximum with wrench. **DO NOT OVER TIGHTEN.**

## Disassembly

**⚠ WARNING**

Do not dismantle under operating pressure.

- A. Loosen union nuts (1) and remove valve body (2) from line.
- B. Support valve body with minimum pressure in clamp or vice. Turn handle (5) to open position.
- C. Using pick or small screwdriver, extract locking strip (3) from recess. Complete removal by gripping end with pliers and pulling in a counter-clockwise motion around valve body.
- D. Turn valve to closed position. Using a wooden dowel, carefully tap ball (9) in direction of locking strip until ball and carrier (4) are removed.
- E. Pull handle (5) from stem (6). **Note:** Some models require removal of small metal screws at base of handle.
- F. Remove stem by pressing into valve body

### Assembly

- A. Inspect body and ball for excessive wear or damage. Replace complete valve if these components are damaged.
- B. Roll stem seal O-rings (7) into grooves on stem and insert in valve body.
- C. Install teflon seal (8) in solid end of valve body. Bevel side of seal must be towards valve ball.
- D. Install valve ball.
- E. Install handle and turn ball to open position.
- F. Roll carrier seal O-rings (10) in groove on carrier.
- G. Install teflon seal in carrier with bevel side toward valve ball.
- H. Install carrier in valve body. Install locking strip with clockwise motion until rectangular end snaps in place in valve body.
- I. Install face O-rings in valve body and carrier grooves.

**FREIGHT CONDITIONS:**

All orders are shipped F.O.B. Once the material leaves our dock, it becomes the property and responsibility of the consignee. If freight is lost or damaged, all freight claims must be filed with the freight company. When shipping to a job site, freight will be third party billed.

**FULL FREIGHT ALLOWANCE:**

To meet the full freight allowance, orders must be for immediate complete shipment to one location within the contiguous United States. Shipments to Alaska, Puerto Rico, Hawaii or for export are not freight allowed. For shipments to Alaska, Puerto Rico, Hawaii or for export, the freight allowances shown below, for qualified items, are good for shipment to East Coast, West Coast, Gulf Coast, or Great Lakes ports only.

1. **Single Wall PP and PVDF Products:** \$10,000 Net on single wall pipe and fitting products, EXCLUDING Sinks, Tanks and related accessories, Chemical Treatment Systems, 8"-12" (inclusive) Pipe and Fittings.

**PAYMENT TERMS:**

The invoices are due and payable 30 days from the date of invoice.

**ORDER ACCEPTANCE AND PURCHASE ORDER FORMS:**

All orders are subject to acceptance by us at our facility. Prices and discounts contained in any of our catalogs, price lists or other literature are subject to change without notice. Your order, when shipped by us, shall be subject to these terms and conditions. Orders submitted on your own purchase order forms will be accepted only with the express understanding that no statements, clauses, or conditions contained in said order form will be binding on us if they are inconsistent with or in any way modify our own terms and conditions of sales.

**MINIMUM ORDER CHARGE:**

A minimum billing charge of \$200.00 Net applies to all shipments F.O.B. factory. Customers are encouraged to order sufficient product to avoid this charge which is necessitated by increased costs of processing small orders.

**SPECIAL PRODUCTS:**

Orders for special or modified products are non-cancelable. In the event that the customer cancels an order for such products, we shall charge the customer an amount equal to our costs and expenses incurred in performing the purchase order prior to receipt of notice of cancellation.

**LIMITED WARRANTY:**

Watts Regulator Co. (the "Company") warrants each product to be free from defects in material and workmanship under normal usage for a period of one year from the date of original shipment. In the event of such defects within the warranty period, the company will, at its option, replace or recondition the product without charge.

THE WARRANTY SET FORTH HEREIN IS GIVEN EXPRESSLY AND IS THE ONLY WARRANTY GIVEN BY THE COMPANY WITH RESPECT TO THE PRODUCT. THE COMPANY MAKES NO OTHER WARRANTIES, EXPRESS OR IMPLIED. THE COMPANY HEREBY SPECIFICALLY DISCLAIMS ALL OTHER WARRANTIES, EXPRESS OR IMPLIED, INCLUDING BUT NOT LIMITED TO THE IMPLIED WARRANTIES OF MERCHANTABILITY AND FITNESS FOR A PARTICULAR PURPOSE.

The remedy described in the first paragraph of this warranty shall constitute the sole and exclusive remedy for breach of warranty, and the Company shall not be responsible for any incidental, special or consequential damages, including without limitation, lost profits or the cost of repairing or replacing other property which is damaged if this product does not work properly, other costs resulting from labor charges, delays, vandalism, negligence, fouling caused by foreign material, damage from adverse water conditions, chemical, or any other circumstances over which the Company has no control. This warranty shall be invalidated by any abuse, misuse, misapplication, improper installation or improper maintenance or alteration of the product.

Some States do not allow limitations on how long an implied warranty lasts, and some States do not allow the exclusion or limitation of incidental or consequential damages. Therefore the above limitations may not apply to you. This Limited Warranty gives you specific legal rights, and you may have other rights that vary from State to State. You should consult applicable state laws to determine your rights.

SO FAR AS IS CONSISTENT WITH APPLICABLE STATE LAW, ANY IMPLIED WARRANTIES THAT MAY NOT BE DISCLAIMED, INCLUDING THE IMPLIED WARRANTIES OF MERCHANTABILITY AND FITNESS FOR A PARTICULAR PURPOSE, ARE LIMITED IN DURATION TO ONE YEAR FROM THE DATE OF ORIGINAL SHIPMENT.

**SHIPPING DATES-DELAYS-SHORTAGE CLAIMS:**

All shipping dates given are best estimate only and, therefore, cannot be guaranteed. We will not be liable for any delay in delivery. Any claims for shipping errors, shortages or defects must be made to us within 24 hours of receipt of the goods. The customer shall be required to make timely payment to us of any amount which is undisputed or not subject to such claims.

**RETURNED GOODS POLICY:**

1. Permission to return goods must be requested in written form to us via email, fax or mail. The request must identify original shipment of material by invoice number and date of invoice and list all goods to be returned by Orion part number / MFG number and description. Total value of requested return must meet minimum \$250 Net value to qualify for return authorization due to increased costs of processing small returns.
2. The following are non-cancelable and non-returnable and no credit will be issued on their return: all pipe; all non-standard, special order, or made to order products; all obsolete products; all sinks, tanks and related accessories, sediment interceptors, monitoring equipment, and related accessories; all Standardline products; all 8", 10", 12" fittings; all tools and accessories.
3. Goods must be returned within one year after purchase in order to receive credit.
4. Only 10% of any invoice total (not including the pricing for pipe) may be returned for credit, subject to minimum \$250 Net value as stated above.
5. All goods must be returned "prepaid". For any goods purchased on an FFA basis, outgoing freight charges will be deducted from total credit amount.
6. All goods returned must be in pristine and resalable condition. All returns are subject to our inspection. Any product that is, in our sole judgement, determined not to be in a resalable condition will be either disposed of by us or returned freight collect to the purchaser. In either event, no credit will be given.
7. A restocking charge of 25% will be charged against all returned goods except Whiteline materials for which the charge will be 35%. If goods are returned in a non-pristine condition and need special cleaning to allow them to be resold, a 40% restocking charge will apply to the entire returned shipment.
8. All goods returned must have Orion's return authorization number clearly indicated on all boxes or cartons and must be freight prepaid. If not, they will be refused at our dock.
9. All credit memos issued may be applied to current account balances or to future purchases. No cash refunds will be issued.

**DISCLAIMER:**

**Prices and terms are subject to change without notice and supersede all previous quotations. The right is reserved to change or modify product design or construction without prior notice and without incurring any obligation to make such changes and modifications on products previously or subsequently sold.**

## Notes

Notes





*A WATTS Brand*