

Installation, Operation and Maintenance Manual

UV-COM

Ultraviolet Water Disinfection System

Models: C196, C196M, C196C, C196CM, C222, C222M, C222C, C222CM, C403, and C403M

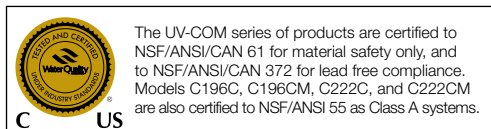
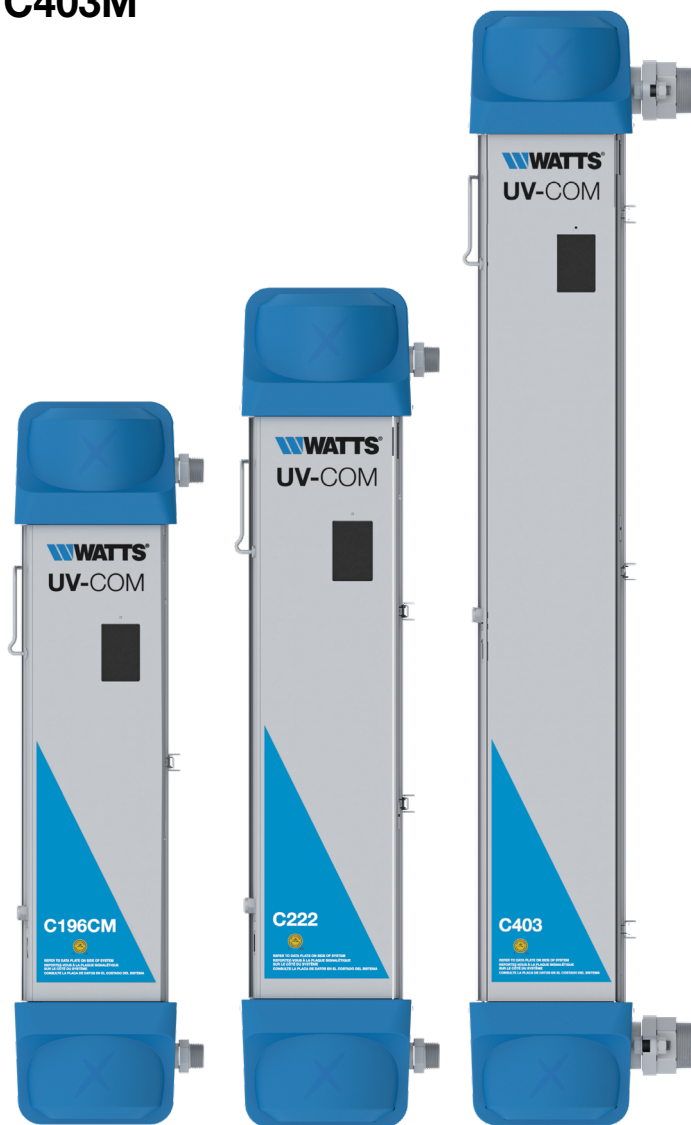

† 120V versions of the product are certified by QPS

Disclaimer:

The information contained in this manual is subject to change without notice from Watts. Watts makes no additional warranty beyond what is set below, including but not limited to, implied warranties of merchantability and fitness for a particular application. Some states do not allow the exclusion or limitation of incidental or consequential damages, so the above limitation may not apply. Watts is not liable for errors appearing in this manual, nor for incidental or consequential damages occurring in connection with the furnishing, performance, or use of these materials.

WARNING



Read this Manual **BEFORE** using this equipment.

Failure to read and follow all safety and use information can result in death, serious personal injury, property damage, or damage to the equipment.

Keep this Manual for future reference.

THANK YOU

By purchasing a UV-COM system with Crossfire® Technology, you can now be certain that your application is receiving world-class treatment.

The Watts UV-COM series of products conform to the applicable provisions of the Code of Federal Regulations (CFR) requirements including, Title 21, Chapter 1, Subchapter J, Radiological Health.

Table of Contents

Section 1: Important Instructions And Safety Information	3
1.1 Grounding Instructions	4
1.2 Ground-Fault Circuit-Interrupter	4
1.3 Safety Symbols	4
Section 2: About the Watts UV-COM	5
Section 3: Product Specifications	6
Section 4: Installation Instruction.....	7
4.1 Before Beginning Installation.....	7
4.2 Assembling the Unit	8
4.3 Connecting the Pipes	9
4.4 Parallel Installation	10
4.5 Control Interfaces	10
4.6 External Contacts	10
4.7 Remote Start/Stop	10
4.8 4-20mA and Modbus Option.....	11
4.9 Data Logging on USB Option	11
4.10 Change Purging and Hot Water Alarm Setups for 131°F Hot Water Operation	12
4.11 Change Wiper Cycle Time For 131°F Hot Water Operation	13
Section 5: Operating Instructions.....	14
5.1. Unit Functions	14
5.2 Navigating the Menu.....	15
5.3 Plugging in the Watts UV-COM for the First Time.....	16
5.4 Flushing Instructions.....	17
5.5 Shutting Down of Unit and Seasonal Use	17
5.6 Disinfecting the Plumbing	17
5.7 Automatic Quartz Sleeve Cleaning Device	17
5.8 Built in Purge Valve.....	17
Section 6: Troubleshooting	18
Section 7: Maintenance	19
7.1 Accessing the UV Chamber.....	19
7.2 Replacing and Cleaning UV Lamps.....	20
7.3 Draining the Unit.....	22
7.4 Cleaning the Unit	22
7.5 Determining the Need for Cleaning	22
7.6 In-place Cleaning.....	22
7.7 Disassembling the Unit	23
7.8 Cleaning/Removing the Quartz Sleeve	24
7.9 Reassembling the Unit.....	24
7.10 Replacement Parts.....	25
7.11 UV-COM Spare Parts List.....	27
Section 8: Service Record Sheet	28
Section 9: Performance Data Sheets	29
Section 10: WQA Statement.....	31
Section 11: Watts UV-COM Limited Warranty	32

Section 1: Important Instructions And Safety Information

CAUTION

When operating the Watts UV-COM unit, basic precautions should always be followed to reduce the risk of fire, electric shock, and injury to persons, including the following:

1. Read all the instructions before installing or operating the system.
2. Pay attention to all warning and caution statements, and also safety symbols throughout these instructions. Failure to do so may result in personal injury and/or damage to equipment.
3. This unit is not intended for use by persons (including children) with reduced physical, sensory or mental capabilities, or lack of experience and knowledge, unless they have been given supervision or instruction concerning use of the unit by a person responsible for their safety.
4. Do not contact moving parts.
5. Only use attachments or spare parts recommended or sold by Watts.
6. The unit must only be used indoors in a dry location.
7. Do not unplug the unit by pulling on cord. To unplug, grasp the plug, not the cord.
8. Unplug the unit from the outlet when not in use and always before any servicing or cleaning.
9. The UV chamber contains an interlock to disable the UV lamps in the event the chamber is accessed when the power is on. Do not defeat its purpose or attempt to service without opening the panel completely.
10. Never operate the unit with a damaged cord or plug, or after a significant malfunction or is dropped or damaged in any manner. Return the unit to Watts for examination, repair, or electrical or mechanical adjustment. If the supply cord is damaged, it must be replaced by a special cord available from Watts.
11. Connect the unit only to a circuit that is protected by a ground-fault circuit-interrupter (GFCI). See Grounding Instructions.
12. If an extension cord is necessary, the cord should contain a ground and be rated for the same amperage as the unit or combined units.
13. Do not plug in the unit if water is present on the unit or if any nearby piping connections are leaking.
14. Service to the unit does not require the removal of the aluminum endplates and they must remain assembled.
15. In the event of an alarm or shut down of the Watts UV-COM, and water continues to flow, either accidentally or for emergency purposes, or if the UV system is bypassed, it is recommended that any water used for drinking be boiled.
16. Do not operate the unit dry.
17. Do not operate this unit at altitudes over 3000m. At very high elevations, the thinner air provides less insulation against electrical arcing, which could increase the risk of electric shock. If any arcing does occur, the grounding will prevent injury and GFCI provides additional protection. It is worth noting that Watts UV-COM products operates at low voltages, and electrical shock risks are typically more significant at voltages of 600V or higher.
18. If the unit is installed in a room storing chemicals or is exposed to unnatural substances such as hydrogen sulfide, the room must be ventilated. Certain chemicals such as hydrogen sulfide, is highly corrosive gas that might attack the stainless steel, quartz sleeves, or electronic components if not ventilated.

Section 1: Important Instructions and Safety Information

1.1 Grounding Instructions

The Watts UV-COM series of products must be grounded. In the event of a malfunction or breakdown, grounding will reduce the risk of electric shock by providing a path of least resistance for electric current. This unit is equipped with a cord having an appliance-grounding conductor and a grounding plug. The plug must be plugged into an appropriate outlet that is installed and grounded in accordance with all local codes and ordinances. The piping connected to the Watts UV-COM must also be properly grounded. Install a grounding lug or strap as required.

⚠ WARNING

For correct operation it is essential to observe the manufacturer's instructions.

⚠ WARNING

Improper connection of the equipment-grounding conductor can result in a risk of electric shock. Check with a qualified electrician or service representative if you are in doubt whether the unit is properly grounded. Do not modify the plug provided with this unit; if it will not fit the outlet, have a proper outlet installed by a qualified technician.

1.2 Ground-Fault Circuit-Interrupter

To comply with National Electrical Code, NFPA 70, the circuit where the Watts UV-COM is connected must be protected by a ground-fault circuit-interrupter (GFCI). Watts recommends the use of Hubbell GFCIs for 120Vac.

1.3 Safety Symbols



WARNING: Potential Shock Hazard – Immediately shutdown and unplug the unit before servicing.



DANGER: Ultraviolet Radiation - Disconnect power before replacing lamps. The lamps in the unit emit ultraviolet (UV) light that can damage the skin and eyes. Never look at the lamp when it is operating. Do not plug the unit in unless it is properly installed and all the panels are closed and secured. Do not open a panel or perform any service unless the unit has been unplugged. Never look into the unit or place any exposed skin into the illuminated areas when it is operating. Do not operate a unit that has been damaged or missing any components or safety devices. If a part is missing from your unit, contact Watts Customer Service at 1-800-659-8400



CAUTION: Safety Alert - Pay attention to the instructions.



CAUTION: UV Lamps Contain Mercury - UV lamps are fragile and must be handled with care. If breakage occurs, avoid inhalation or ingestion of debris and avoid exposure to skin and eyes. Do not use a vacuum cleaner or broom for cleanup. Follow local guidelines and regulations to remove and dispose of old UV lamps or mercury debris.



CAUTION: Wear appropriate safety equipment - Wear safety glasses when performing maintenance on the unit. For non-potable applications, do not handle wetted parts with bare hands - use latex or vinyl gloves or equivalent.



CAUTION: Quartz sleeves are fragile - The quartz sleeve can break or chip if mishandled. Always handle with care and keep it in a safe place if removed from unit. Do not strike the quartz sleeve with any tool, since even the smallest chip can cause it to break under pressure. If the quartz sleeves are chipped, they cannot be used and must be replaced

Section 2: About the Watts UV-COM

The Watts UV-COM series of products are the world's only ultraviolet water disinfection device with patented Crossfire Technology.

Patented in US 6,707,048, Canada 2,463,503, Australia 2,002,333,084, Mexico 248805

Patent Pending in Japan, UK, Europe, and Eurasia.

Revolutionary Crossfire Technology is self-cleaning, self-monitoring, and fail-safe. The Watts UV-COM series of products with Crossfire Technology are designed to eliminate the potential risks associated with conventional single lamp UV systems.

Committed to exceeding UV disinfection standards, Watts UV-COM products have turned conventional technology inside-out by flowing the water inside the quartz sleeve and including two lamps mounted in air, dual or quad smart sensors, software-designed reflectors and an optional fail-safe auto shutoff valve.

Crossfire Technology delivers a high UV dose for disinfection: Crossfire Technology incorporates two proprietary high-output UV lamps with software-designed reflectors that provide radiation from 360°. Amalgam UV lamp technology has been introduced into the largest units to not only provide higher UV output, but also increased stability over a wider range of operating temperatures.

Crossfire Technology is capable of treating low UVT water: The Ultraviolet Transmittance (UVT) of water impacts the amount of treatment since UV light is absorbed rather than being available for disinfection. With a shorter path length for the UV light to travel, Crossfire Technology outperforms conventional UV systems and can treat potable applications as low as 50% UVT and also reuse and waste water in low UVT applications.

Crossfire Technology is engineered to be risk-free and fail-safe: Crossfire Technology uses dual or quad smart UV sensors mounted in air, which are designed to not foul and are more reliable indicators of system performance than ordinary systems. The fan-cooled lamps maintain consistent UV output for maximum delivery. Computerized alarms and optional auto shutoff fail-safe valve are designed so that only treated water will pass through the unit.

Crossfire Technology is self-cleaning: Crossfire Technology uses a stainless steel wiper to clean the inside of the quartz sleeve eliminating fouling and the need for a water softener making abrasive quartz sleeve cleaning a thing of the past – saving money and the environment. The wiper is automated to cycle for 5 minutes every 4 hours. The cycle begins 5 minutes after power is applied.

Crossfire Technology is virtually maintenance-free: Crossfire technology utilizes two lamps mounted in air, outside the quartz sleeve so maintaining a Watts UV-COM unit is as easy as changing a light bulb with no system draining required. The UV lamps require replacement after 12 or 16 months of operation depending on the lamp type and notification of lamp replacement is given via a warning one month in advance.

Crossfire Technology is easy to install: Provided with either 1" or 2" male NPT connections. Optional stainless steel flexible hoses with Female Iron Pipe (FIP) connections are available for purchase for quick and simple installation.

The Watts UV-COM units have a smart display: The operator interface is a color touchscreen designed to allow unprecedented access to information such as lamp lifetime, real-time message history and UV dose display. A real-time clock is now available for improved troubleshooting and fault resolution.

The Watts UV-COM units have a built-in purge valve: The purge valve eliminates the need to shut down the unit in the event of no water flow for hours, or even days (as long as a pressurized water supply is present). It is designed to prevent buildup of metals and minerals on internal components. The purge valve also eliminates nuisance alarms from changing water transmittance conditions.

The Watts UV-COM units have remote status indication: The units come standard with warning and run contacts to remotely signal a control panel. In addition, the units can be started and stopped via external device.

The Watts UV-COM units have a built-in surge protection: The power distribution circuit board contains filters and surge protection devices to increase the reliability of the on-board electronics and ballasts for the UV lamp.

The Watts UV-COM units offer new interfaces: The Watts UV-COM units are available with a pair of 4-20mA outputs for UV Intensity, Net UV Transmittance, or UV Dose through an optional add-on device. The Watts UV-COM units also provide a 4-20mA input for flow measurement. Modbus, a smart electronic communication protocol, will also be available when the 4-20mA option is purchased.

The Watts UV-COM units offer data logging: The Watts UV-COM units are available with an optional USB drive to continuously record performance on a daily basis.

Section 3: Product Specifications

Specifications and Features common to all Watts UV-COM units

Call customer service if you need assistance with technical details
1-800-659-8400.

Operating Pressure ¹	5-100 psig (34-690 kPa)
Water Temperature Range ²	34-131°F (1-55°C) ⁴
Air Temperature Range ²	34-104°F (1-40°C)
Maximum Relative Humidity ³	70%
Voltage Input	120Vac 50/60Hz See power input label on left side of unit near power cord.
Manifold materials	316 Stainless Steel
External Contact	2 available - Standard
Remote Start/Stop	Standard
Data Logging to USB Drive	Optional on all units
Automatic Shutoff Valve	Optional on all units
Wetted Parts	Meets NSF/ANSI/CAN 61 and NSF/ANSI/CAN 372

¹ Purging requires pressure to work properly. The optional shutoff valve requires min. 8psig (55kPa) to operate.

² In extreme conditions, high air temperatures may require lower water temperatures for proper operation and vice versa.

³ For continuous flow potable applications, it is recommended to dehumidify the room where the UV unit is located.

⁴ The default setting for water temperature range is 34-104°F except for model C403, which has a default range of 34-95°F. For hot water applications, refer to sections 4.10 and 4.11 to change the purging, hot water alarm, and wiper cycle time settings.

Flow restrictors limit the water flow through the UV unit despite the demand or the amount of supply pressure. A flow restrictor is mandatory for an NSF/ANSI 55 Class model.

⚠ WARNING



Removal of the flow restrictor device on models C196C, C196CM, C222C or C222CM may allow the water flow to exceed the validated performance of the system which therefore may not provide the necessary UV dose for effective treatment.

Potable Water

WATTS UV-COM MODELS	C403*	C222C*	C222*	C196C*	C196*
Max. Flow Rate ¹	100 gpm	27.4 gpm	40 gpm	16.5 gpm	37 gpm
Performance Certifications	–	NSF/ANSI 55 Class A	–	NSF/ANSI 55 Class A	–
Min. UVT for 40mJ/cm ² Dose	95%	75%	95%	75%	95%
Flow Restrictor	Optional	Yes	Optional	Yes	Optional
Pressure Drop	5 psi	22.7 psi ²	13 psi	22.7 psi ²	10 psi
Lamp Type	Amalgam	LPHO	LPHO	LPHO	LPHO
Lamp Life ³	16 months	12 months	12 months	12 months	12 months
Cycles/day ⁴	6-12	6-12	6-12	6-12	6-12
UV Sensor	Quad	Dual	Dual	Dual	Dual
Built-in Purge Valve	Standard	Standard	Standard	Standard	Standard
Automatic Quartz Sleeve Cleaning Device	Standard	Standard	Standard	Standard	Standard
Wiper Position Switch	Standard	Standard	Standard	Standard	Standard
Lamp Heaters	No	Standard	Standard	Standard	Standard
4-20mA Output	Optional	Optional	Optional	Optional	Optional
Modbus connectivity	Optional	Optional	Optional	Optional	Optional
Power Draw	403W	222W	222W	196W	196W
Inlet and Outlet Port size	2" MNPT	1" MNPT	1" MNPT	1" MNPT	1" MNPT
Nominal Dimensions (H x W x D)	56x11x9" (142x29x 22cm)	40x10x9" (103x24x 22cm)	40x10x9" (103x24x 22cm)	36x10x9" (93x24x 22cm)	36x10x9" (93x24x 22cm)

* The specifications also apply to each model's Modbus version, including C196M, C196CM, C222M, C222CM, and C403M.

¹ Based on UV Dose of 40mJ/cm² at alarm setpoint.

² Values presented are at 75% of maximum flow capacity. The flow restrictor adds significant pressure drop.

³ Amalgam lamp lifetime is 12,000hrs/500 days and LPHO lifetime is 9000hrs/375 days

⁴ Exceeding the recommended daily cycles will accelerate the age of the UV lamps. LPHO lamps perform more reliably when operated 24/7.

Section 4: Installation Instruction

4.1 Before Beginning Installation

4.1.1 Water Conditions - Pre-treatment Parameters

Note this section is designed to ensure the optimal performance of your Watts UV-COM system. Please review the following pre-treatment parameters prior to installation. If any specifications are of concern or unclear please contact Watts Technical Services.

IMPORTANT: Should any of the following water parameters exceed the recommended limits the system will not be serviceable under warranty.

DO NOT INSTALL THE WATTS UV-COM system until you have confirmed the unit's capabilities matches the application – see Product Specifications Tables.

Water Parameters for Treating Potable Water:

- UV Transmittance (UVT) – see Product Specification Tables. It is recommended for the water to be tested for UV transmittance in any applications using cisterns, surface water or ground water under the influence of surface water.
- Total Dissolved solids (TDS) - must be less than or equal to 1000 mg/L (mg/L=ppm)
- Level of turbidity - or cloudiness - of less than or equal to 1 NTU (nephelometric turbidity unit). In a point of entry application, a 5 micron sediment filter is recommended before the unit to reduce turbidity (the presence of a filter will also simplify disinfection of plumbing – see Disinfecting the Plumbing section). For surface waters, a dual gradient pre-filter (75x25 or 50x5) is recommended.

4.1.2 Parts Included

- UV system complete with integral wall brackets (1)
- Ultraviolet lamps (2) – installed within the unit
- Instruction manual (1)
- Power cord (1) (located within packaging)
- 20 feet of flexible hose to connect purge valve to drain (if applicable)
- Flow Restrictor (only for NSF/ANSI 55 Class A units)

Optional:

- Automatic shutoff valve
- Stainless flexible hoses (useful for installation and maintenance)
- Pre-treatment sediment and or carbon filter designed to remove water particles, odor or trace chemicals for improved taste.
- Strain Relief Kit for external wiring

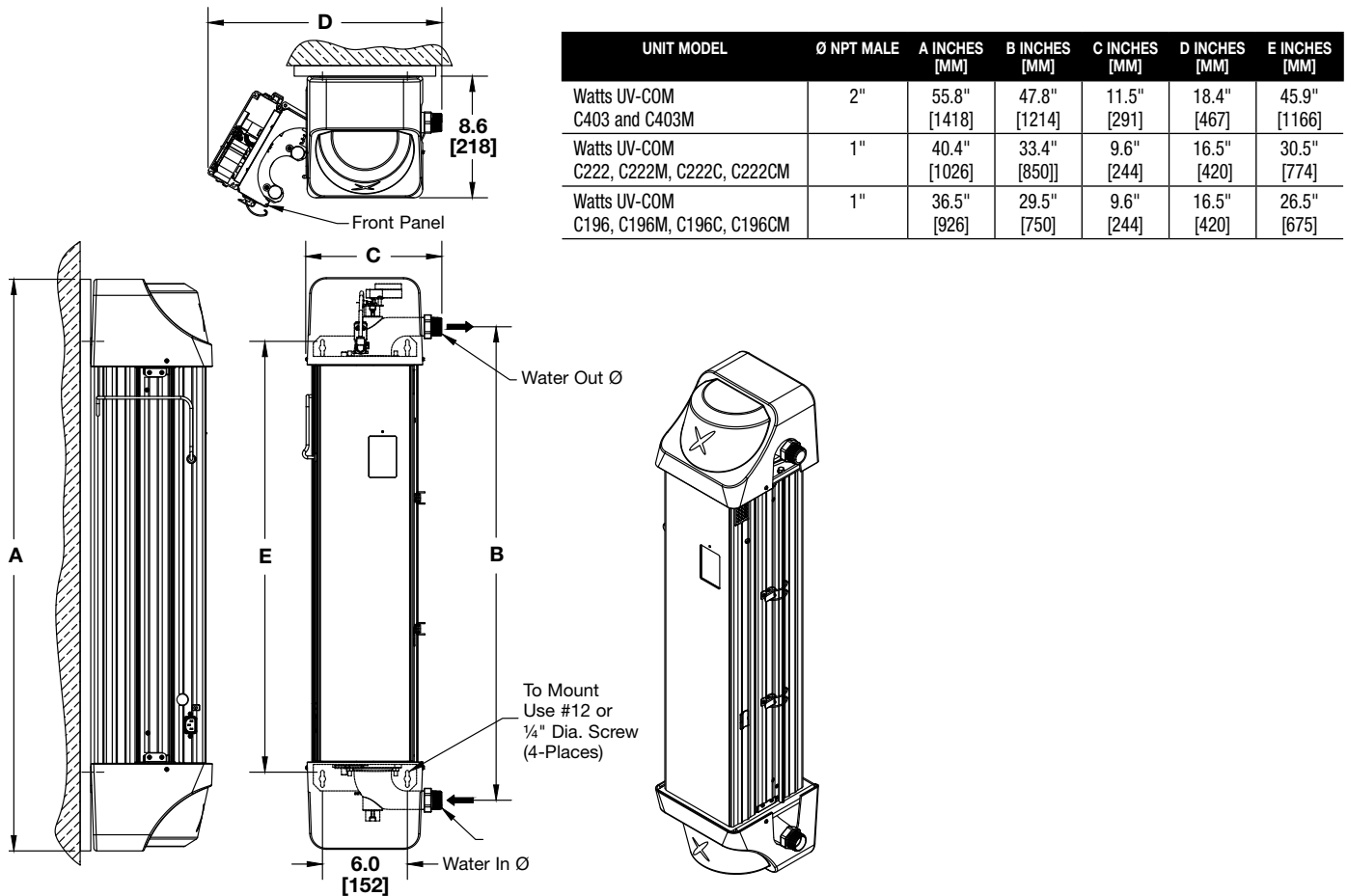

Figure 4-1

Section 4: Installation Instruction

4.1.3 Other Materials Needed

The Watts UV-COM products require four #12 to ¼" diameter fasteners (not provided) to mount to a wall. Pipe insulation is recommended for any overhead piping to prevent condensation from dripping onto unit. The unit also requires a drain for the purge valve discharge line.

⚠ WARNING

Use only copper or stainless steel piping at the UV outlet since water temperatures can reach 176°F (80°C) if the UV unit operates without water flow or the ability to purge. DO NOT USE PVC.

These fittings, pipe insulation, and any piping compatible with the plumbing should be on hand before you begin installation. See Figure 4.2 and make a list of all necessary components including solder, paste and thread sealant. Bypass piping and valves that isolate the unit are optional, (but recommended) as is a drain valve for draining the unit.

4.1.4 Tools Needed

- Pipe cutter, torch and other typical plumbing tools for modifying piping
- Wrench for tightening hose connections
- Phillips screwdriver
- Slotted screwdriver

4.1.5 Location

⚠ WARNING

The unit must be positioned vertically on a solid wall (the performance of the system will be adversely affected if mounted horizontally or is subjected to vibrations). Installation should be done in compliance with all applicable federal, state/provincial, and local regulations. We recommend that the unit be installed by a qualified service technician. Failure to install the system properly may result in property damage (leaks/flooding) or personal injury (electrical shock) and will void warranty.

In a potable water application, the Watts UV-COM products should be installed downstream of (after) any pre-treatment devices such as filters, water softeners etc. and also any pressure tanks. However, it must be installed before any branches in the piping so that all the water is disinfected before splitting and distributing throughout the home or facility. The unit must be before any chlorine injection system or this will void warranty.

4.1.6 Time Required

Please note that full installation of the UV-COM requires shutting off the main water supply for a number of hours. If disinfection is necessary, all pipes and any pre-treatment devices must be treated and flushed. Once the unit is plugged in, the new UV lamps may take from a few moments to several hours to reach full power depending on the type of lamps. Having a Dose Alarm is normal with a new system (or with newly installed lamps) until the lamps have reached full power.

Summary of Installation:

- Unpack and install UV-COM on a wall
- Prepare connections to inlet and outlet ports
- Install purge valve discharge line to a suitable drain line
- Install optional shutoff valve
- Install optional bypass and drain plumbing
- Check for leaks
- Install insulation to overhead piping
- Connect system power cord from unit to GFCI

⚠ WARNING

If connected to a potable water system, the system must be protected against backflow.

4.2 Assembling the Unit

1. Unpack the unit, being careful to remove all packaging material. Inspect the unit for damage particularly the quartz sleeve – See the Accessing UV Chamber section. Check if UV lamps are fully inserted. Write model number, serial number, and installation date on front on the Instruction Manual.
2. The UV unit has keyhole slots for convenient mounting – use all four mounts. Do not mount the unit directly to an outside wall; mount on plywood or shims – See Figure 4.1. Remove the top and bottom covers of the unit to make the mounting holes accessible. Mounting hole templates are provided to simplify installation.
3. The unit can be connected directly to the water mains or using the optional Stainless flexible hoses purchased through Watts. Use only new hoses; old hoses should be discarded. If hoses are being used, connect them now to both the top and bottom of the unit. Make sure that the sealing washer is inside the hose end before making the connection. Hold the stainless manifold with a wrench then tighten the hose securely.

Section 4: Installation Instruction

4.3 Connecting the Pipes

⚠ WARNING

Water must flow into the inlet at the bottom of the unit. The outlet is located at the top of the unit. For 1" systems, hold the stainless manifolds with a wrench when tightening mating connections. For 2" systems, the pump flange should be removed and threaded into mating connection then reconnected to UV unit. Do not damage sealing surfaces.

⚠ CAUTION

Always shut off water supply and relieve water pressure before beginning any plumbing modifications.

1. See Figure 4.2 on how to arrange the piping and optional devices such as the auto shutoff valve, bypass line, sample ports and drain. If the pressure tank is downstream of the unit, a purge valve relocation kit is required.

2. The optional auto shutoff valve ensures that should the system fail, due to power loss, low UVT or low UV lamp output, the system will fail in safe mode and shut down the water flow. It is recommended to install the auto shutoff valve just after the UV unit provided that a flood detection device exists at the site – this allows the unit to purge during alarm situations. If a flood detection device is not present, install the auto shutoff valve ahead of the UV unit. The auto shutoff valves are omni-directional and do not require minimum pressure to open.

The optional auto shutoff valve is normally closed and must be powered to open.

Some of the auto shutoff valves offered have a manual override (white lever) that can be used to force the valve open. In any regulated sites such as municipal applications, the manual override should not be used. For normal operation, always leave valve in automatic position. In the Advanced Settings menu, item 2.7.3, toggle the valve to be "Installed" and a monthly reminder will appear to test valve. Please test valve monthly.

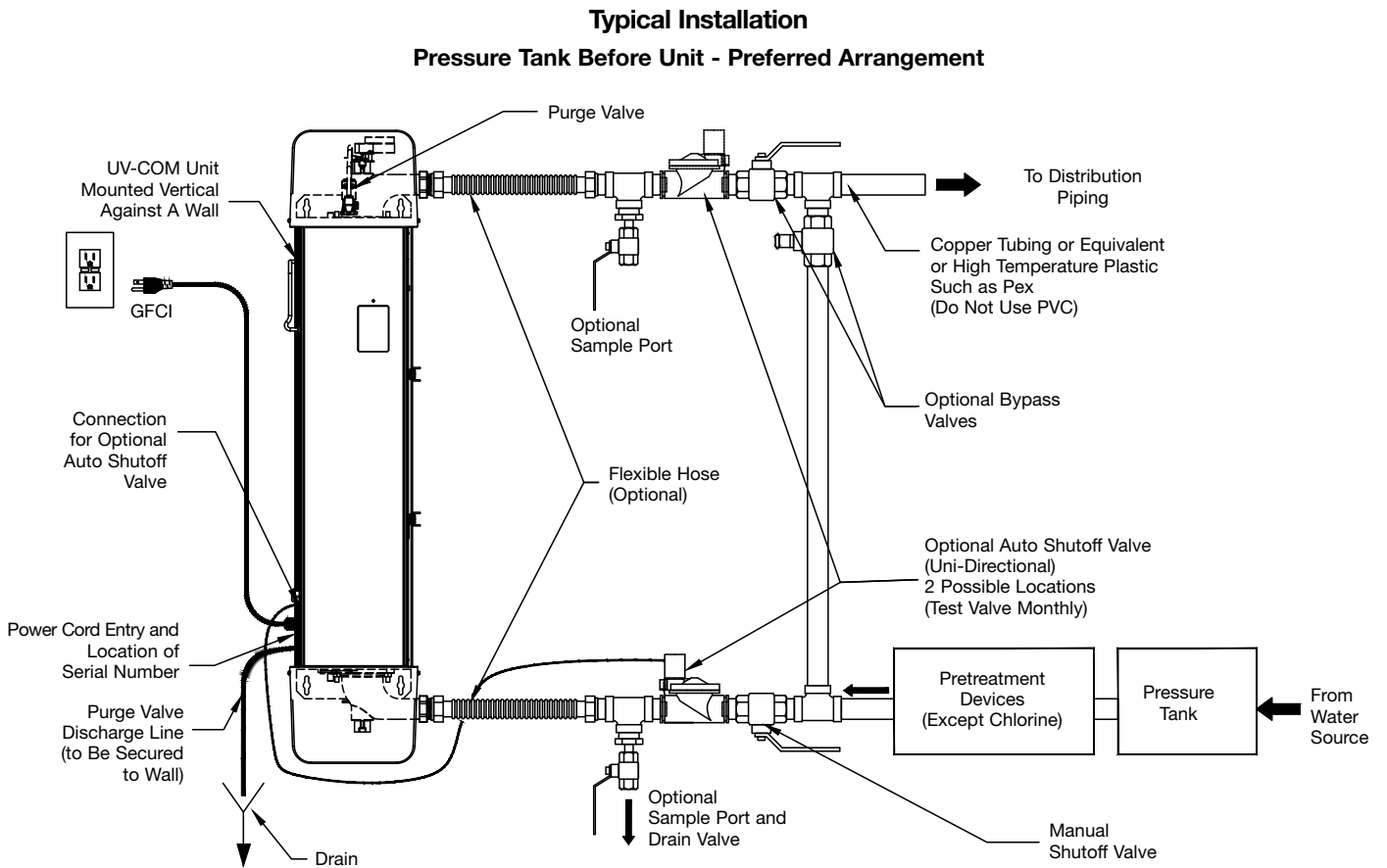

Figure 4-2

Section 4: Installation Instruction

3. Connect the purge valve to a drain using the tubing provided – see Figure 4.3. Note that an air gap of two pipe diameters or 25 mm (1 in), whichever is larger, is required between tubing and drain - follow local plumbing regulations. The tubing can be placed down the back side of the unit. The tubing should be secured to the wall or floor to prevent it from moving during the purging cycle. **During startup of the unit, test the purge valve to confirm connections are free of leaks and the water discharges to drain.**

⚠ CAUTION

Do not allow the inside of the unit to get wet. Before opening the water supply, double check all connections and taps. Slowly turn on the water supply, vent out trapped air and check for leaks. If leaks exist, investigate the cause and repair before plugging in the unit.

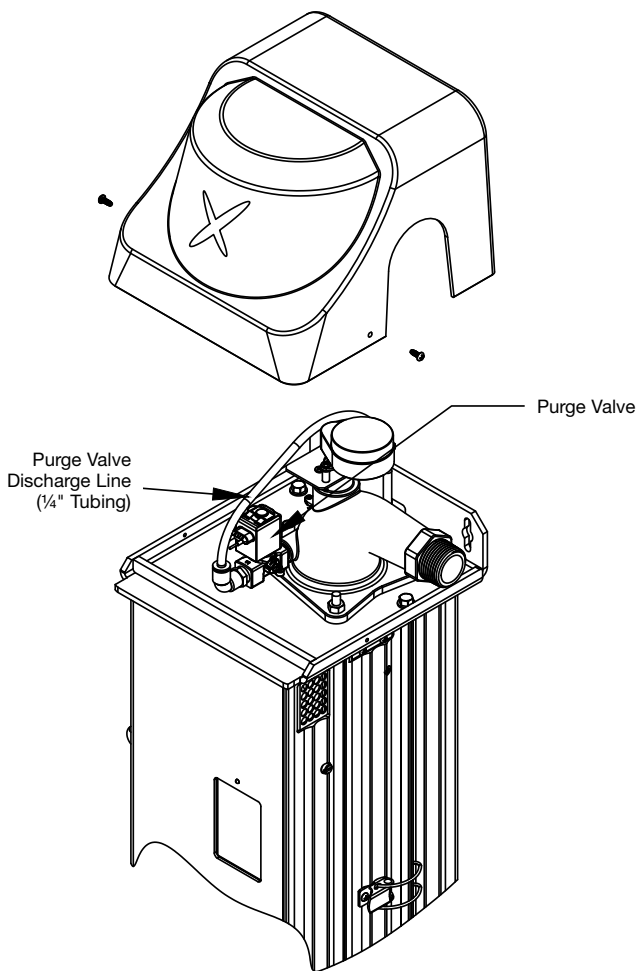

Figure 4-3

4. Once the system is checked for leaks under full pressure, install pipe insulation to any overhead piping to prevent condensation from falling onto or into the unit.

IMPORTANT: After the unit has been operating for a few hours, check all connections for leaks (specifically at flexible hoses if purchased). Repeat this procedure periodically.

4.4 Parallel Installation

When more than one unit is installed in parallel (flow split between units), the units must be installed with manual shutoff valves both upstream and downstream of each unit to allow one unit to be serviced without interrupting the flow to the others. Another requirement is the installation of a check valve downstream of the UV unit (after the UV unit). This will prevent the backflow of water to a unit.

4.5 Control Interfaces

⚠ WARNING

Shutdown and unplug the unit before installing any external wiring.

External wiring can be introduced through a port in the left side of the unit – see Figure 4.4. By default, a plug is installed into this port in a standard unit and a strain relief can be purchased if connection to remote devices is required. For External Contacts and Remote Start/Stop, 20 gauge wire is recommended and if the 4-20mA option is used, 20 gauge wire with foil and drain wire. Install wires onto spring cage terminals provided.

4.6 External Contacts

All UV-COM systems provide two “dry” contacts for remote alarms or auto-dialers – the word “dry” indicates no voltage present at the contact. The first contact labeled RUN is a “System Run” condition – when closed, the unit is treating; if the contact is open, the unit is in alarm, has lost power, or perhaps the wire has been cut. The second contact labeled WARNING is to indicate the existence of an abnormal condition such as high water temperature. When this contact is open, the system is normal; when this contact is closed, a warning condition exists. Both contacts are meant for control purposes only, not to drive devices. The maximum rating of the contact is 24 Vac or Vdc, 2A.

4.7 Remote Start/Stop

All UV-COM systems have remote start/stop capability which allows them to remain idle without operating the UV lamps. When a signal is given (voltage applied), UV lamps are energized. This is convenient for locations requiring periodic disinfection such as pump houses. The voltage rating range of the contact is 5-24 Vdc or Vac, 0.5W max. The remote start/stop is disabled by default and can be enabled in the Advanced Settings menu.

⚠ CAUTION

Avoid continuously starting and stopping the unit within a 24 hr period, as this will accelerate the aging of the UV lamps and will not be covered under warranty. See Product Specification Tables for permissible lamp cycles.

Section 4: Installation Instruction

4.8 4-20mA and Modbus Option

A 4-20mA option is available with two continuous analog output signals and one input signal. The output signals can be UV Dose, or UV Intensity, or UV Transmittance. The input signal is flow (on C403 models only). Modbus capability will also be available when the 4-20mA option is purchased.

4.9 Data Logging on USB Option

Data logging capability is an available option on all UV-COM units. A small USB drive is used to record system performance every 30 seconds. The USB drive can store up to 4 years' worth of daily records.

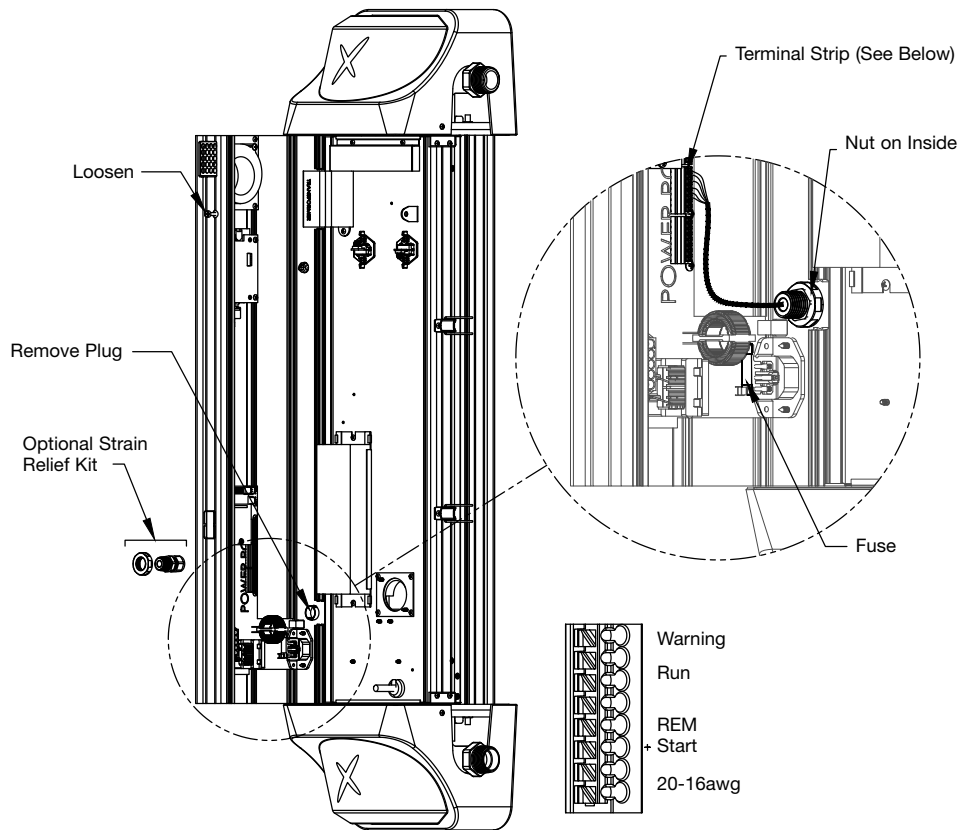

Figure 4-4

Section 4: Installation Instruction

4.10 Change Purging and Hot Water Alarm Setups for 131°F Hot Water Operation

In hot water applications (for up to 131°F/55°C water temperature), the system settings must be adjusted to avoid unnecessary alarms and hot water scale buildup on the quartz sleeve. To operate the unit at the elevated water temperatures of 131°F (55°C) the default settings for the purging and high water temperature alarm must be changed. Note that altering the setpoints may affect the long term cleanliness of the quartz sleeve leading to additional maintenance.

IMPORTANT: Altering the setpoints will also negate the warranty on the quartz sleeve.

Default values:

MODEL	C403	C222 AND C196
Purge Setpoint	95°F (35°C)	104°F (40°C)
H2O On Time	60 seconds	30 seconds
Valve Debounce	30 seconds	30 seconds
Warning Delay	120 seconds	120 seconds
Temperature Alarm SP	113°F (45°C)	122°F (50°C) (Disabled)
Dose On Time	60 seconds	60 seconds

Setpoints for 131°F (55°C) water operation:

MODEL	C403	C222 AND C196
Purge Setpoint	131°F (55°C)	131°F (55°C)
H2O On Time	60 seconds	30 seconds
Valve Debounce	30 seconds	30 seconds
Warning Delay	120 seconds	120 seconds
Temperature Alarm SP	140°F (60°C)	140°F (60°C) (Disabled)
Dose On Time	60 seconds	60 seconds

To change the purge valve temperature setpoints, do the following:

1. Navigate to the Settings menu and go to Unlock System.
2. Enter the password 8324.
3. Go down to the Purge Valve menu.
4. Click on the words purge setpoint.
5. Change the purge temperature in Celsius to 55°C.
6. Hit OK and return to the main page.

Number of seconds the purge valve stays on to regulate water temperature. Range 1-600s

Number of seconds from when the purge valve opens until the warning is issued in the temperature does not drop below setpoint

Number of seconds the purge valve stays on when the UV dose drops below alarm set point. Range 1-600s

Section 4: Installation Instruction

4.11 Change Wiper Cycle Time For 131°F Hot Water Operation

The UV-COM models C403, C222, and C196 have an automatic quartz cleaning device called a wiper. The wiper consists of a series of stainless steel “wipers” that are mounted on a shaft in the center of the quartz. The wiper is driven by a 1 rpm motor located at the top of the unit and a positioner is used to park the wiper in the same spot every time. The positioner also provides confirmation that the wiper is functional. The wiper operates for 5-6 minutes at a time.

The first wiper cycle occurs 3 minutes after UV lamp ignition. The next cycle occurs after 4 hours and so on, thus 6 wiper cycles per day. The cycle time can be adjusted from 1- 24 hours by an operator within a password protected menu.

The second screen in the Info menu provides a countdown timer in minutes for the next wiper cycle. When the wiper is cycling, the green LED will quickly flash.

To change the wiper cycle time, do the following:

1. Navigate to the settings menu and go to unlock system.
2. Enter the password which is 8324.
3. Go down to the wiper button now revealed in the “Settings” menu.
4. Click on the words “Cycle Time.”
5. On the keypad, change to desired cycle time in hours.
6. Hit OK and return to the main page.



Section 5: Operating Instructions

The UV-COM applies advanced Crossfire Technology yet is simple to operate. The automatic quartz sleeve cleaning technology has been designed to reduce, and in most cases, eliminate the periodic shutdowns necessary to inspect the cleanliness of the quartz sleeve. The only required maintenance is the replacement of the two UV lamps.

The unit should be operated with both top and bottom plastic covers installed.

5.1. Unit Functions

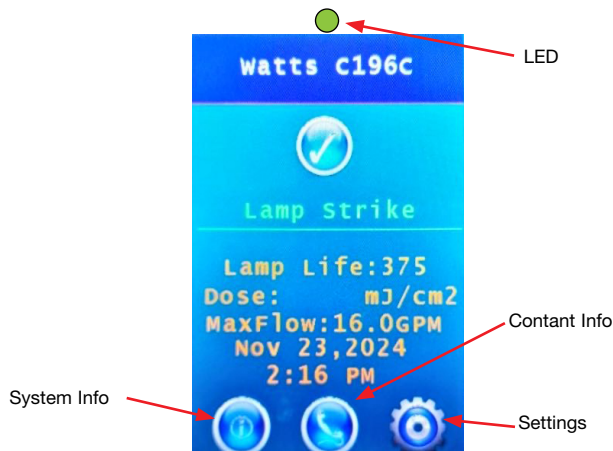

Figure 5-1

The user interface consists of a color touchscreen and a single multi-color LED. See Figure 5.1. The LED will always be illuminated when the UV unit is plugged in and powered up. The touchscreen enters sleep mode after 10 minutes and requires the user to touch it to wake it up. The touchscreen will change colors if any significant event occurs such as warnings or alarms. See the section on Navigating the Menus for a complete layout of the screens.

Indicating LED

Green Light – an illuminated green light indicates the unit is treating normally. A slow flashing green light means the UV lamps are not yet at full power or the unit is in standby mode awaiting a remote start. A fast flashing green light means the wiper is cycling.

Red Light – an illuminated red light indicates either a warning or an alarm has occurred. A warning is a condition that, if not addressed, could impact the unit's performance. Warnings should be addressed as soon as possible. Warnings are accompanied with a flashing red LED, a single beep, a message, and a yellow screen. An alarm is a condition that has significantly impacted the unit's performance and it must be addressed immediately. Alarms are accompanied with a solid red LED, continuous beeping, a message, and a red screen.

Audio Alarm

The audio alarm or beeper, will alert the operator to any conditions out of the ordinary. A single beep will sound if a warning occurs; continuous beeping will sound if an alarm occurs. The audio alarm may be disabled temporarily or permanently in the Settings Menu, item 2.3. The sound level of a unit operating normally is less than 70db(A). However, sound levels can exceed 85 db(A) with the audio alarm on.

Section 5: Operating Instructions

5.2 Navigating the Menus

0	Home		2.7	Advanced Settings
	0.1	Model name	2.7.1	Force Outputs
	0.2	Treatment Status	2.7.1.1	Lamps
	0.3	Lamp Life	2.7.1.2	Wiper
	0.4	UV Dose	2.7.1.3	Purge Valve
	0.5	Max Flow or Flow Signal (Optional)	2.7.1.4	Shutoff Valve
	0.6	Date and Time	2.7.1.5	Fan UV
0A	Contact Info	Text: Company, Phone, Installation date	2.7.1.6	Fan PCB
1	System Info		2.7.1.7	Warning Contact
	1.1	UVT	2.7.1.8	Run Contact
	1.2	UVI	2.7.1.9	Buzzer
	1.3	Left Lamp UV	2.7.1.10	Heaters
	1.4	Left Water UV	2.7.1.11	C1-4-20mA signal
	1.5	Right Lamp UV (If available)	2.7.1.12	C2-4-20mA signal
	1.6	Right Water UV (If available)	2.7.1.13	Interlock for UV door
	1.7	PCB Temp	2.7.1.14	Wiper Positioner switch
	1.8	Sys Temp	2.7.1.15	Remote Start/Stop Signal
	1.9	Water Temp	2.7.1.16	Fault 1
	1.10	Lamp Temp	2.7.1.17	Fault 2
	1.11	Wiper Countdown	2.7.1.18	Lamp Temp
	1.12	Power-ups	2.7.1.19	Water Temp
	1.13	Firmware Version	2.7.1.20	Analog In
	1.14	Total Starts	2.7.1.21	System Temp
	1.15	Daily Starts	2.7.1.22	PCB Temp
	1.16	Life-time counter	2.7.1.23	DC Volts
	1.17	CH1 - Analog Output	2.7.1.24	L Lamp Sensor
	1.18	CH2 - Analog Output	2.7.1.25	L Water Sensor
2	Settings		2.7.1.26	R Lamp Sensor
	2.1	Date and Time	2.7.1.27	R Water Sensor
	2.2	Power Down	2.7.1.28	CAL - L Lamp
	2.3	Audible Alarm	2.7.1.29	CAL - L Water
	2.4	Units (Imperial/Metric)	2.7.1.30	CAL - R Lamp
	2.5	Reset Lamp Counter	2.7.1.31	CAL - R Water
	2.6	Message History (Last 100 messages)	2.7.2	Remote Start
	2.6.1	{Message 1}	2.7.3	Daily Timer
	2.6.1.1	UV Dose	2.7.4	Shutoff Valve
	2.6.1.2	Water Temp	2.7.5	Set Defaults
	2.6.1.3	Estimated UVI	2.7.6	Language
	2.6.1.4	Estimated UVT	2.8	Password for Advanced Menu
	2.6.1.5	Left Lamp UV		
	2.6.1.6	Left Water UV		
	2.6.1.7	Right Lamp UV (If Available)		
	2.6.1.8	Right Water UV (If Available)		
	2.6.1.9	Lamp Temp		
	2.6.2.0	PCB Temp		
	2.6.2.1	System Temp		
	2.6.2	{Message 2}		
	2.6.3	...		

Section 5: Operating Instructions

Typical message screens shown below:

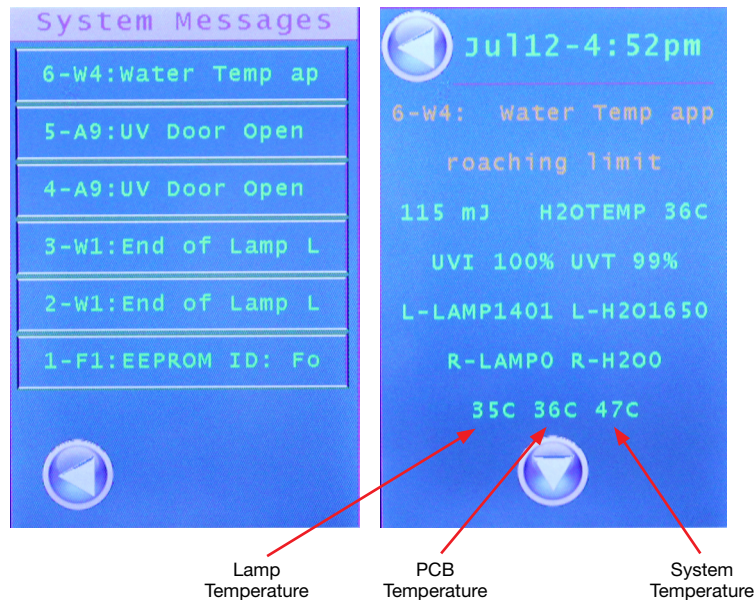

Figure 5-2

5.3 Plugging in the Watts UV-COM for the First Time

1. Ensure that all external wiring is complete (see section 4.5) and all the panels of the unit are closed before connecting the power cord.
2. Plug female end of power cord into power entry module located on left side of the front panel. Plug the male end of the power cord into a ground-fault circuit-interrupter (GFCI).
3. Once the unit is plugged in, the LED illuminates, an audible tone is issued and the display becomes active to confirm all three devices are functional. The unit then performs a self-diagnostic. Enter the date of installation in the Settings Menu and treatment parameters, if required.
4. When the UV Lamps have started, (lamp ignition for amalgam lamps may take up to 30 seconds) the unit will wait at 10 - 15 minutes depending on the model to allow the lamps to stabilize before transitioning into Treating mode. This will occur every time the UV lamps are powered up. During this warm up, the green LED will flash, the unit will display the countdown to startup, and the optional shutoff valve will remain closed. **New LPHO lamps may take from a few moments to several hours to reach full power. Continue to operate the unit until the lamps reach full power – this may last 24 hours. It is recommended for new LPHO lamps to be operated initially 3-4 hours as a burn-in to achieve lamp stability.** When the warm up process is complete, a solid green light appears and the message "Unit Treating" will be displayed. The optional auto shutoff valve will be allowed to open only if treatment levels are adequate, otherwise it will remain closed. This is the normal operating mode of the unit.
5. If a power outage occurs, upon return of the power, the unit will start up automatically and perform a diagnostic check. After a 10-15 minute stabilization period, the unit will begin treating if treatment levels are adequate, otherwise an alarm will be issued if the unit is not treating.
6. Test wiper motor and purge valve - see *Advanced Settings menu, items 2.7.1.2 and 2.7.1.3.*
7. Operator should adjust maximum flow setting if required.

⚠ CAUTION

Avoid continuously starting and stopping the unit within a 24 hr period, as this will accelerate the aging of the UV lamps and void warranty. See Product Specification Table for permissible lamp cycles.

⚠ CAUTION

There must be water in the treatment chamber to prevent damage to internal components.

In the event of a lack of water or water supply being turned off, shutdown the unit until the water supply can be restored. In the event of a power failure, the unit will shut down and the optional auto shutoff valve will close, preventing water from flowing. When the power returns, the unit will automatically restart and perform a self-test. If no faults are detected, the unit will return to normal operation and the optional auto shutoff valve will open. Note: even during a brownout, supply voltage may drop low enough to shut down the unit. If the unit does not automatically restart as described above, shutdown and unplug the unit and plug it in again.

Section 5: Operating Instructions

5.4 Flushing Instructions

Flushing the system is required after installation or after any disassembly and cleaning. Flushing may also be required to remove colored or contaminated water from the unit and any pre-treatment devices. Most filters (if installed) also require flushing prior to use – follow the manufacturer's recommendations.

The system may be flushed manually by disassembling the unit and filling and draining the unit by hand (see In-place Cleaning section). Flushing may also be done while the unit is operating. Plug in the unit and open a tap closest to the unit and have the water flow for at least 15 minutes.

5.5 Shutting Down of Unit and Seasonal Use

To shut the unit down, initiate the Power Down procedure located as the second item in the Settings Menu. When this procedure is complete, simply unplug the unit.

UV-COM products can operate for extended periods of time without water usage as long as pressurized water is present to allow for purging. The unit may be shut down in the case of seasonal residences or during a vacation. If the possibility of freezing exists, the unit and any valves and filters must be drained. (See Draining the Unit section.)

5.6 Disinfecting the Plumbing

Disinfection of the household or facility plumbing should be performed after the UV-COM unit has been installed and is operating. This procedure should also be done if the unit is not functioning normally; if a bypass has been used; or if there has been a high background bacteria count in a water sample. Watts has found that disinfecting the plumbing is the best way to treat any potential bacteria or contaminants in the distribution system prior to system use.



Please note that this procedure is ineffective against protozoa that can be found in surface water or shallow wells under the influence of surface water. Under these circumstances, it is important to perform the disinfecting procedure and then operate the UV-COM unit. Watts has found that this procedure does not work with sediments or heavy biofilm and encrustations, which must be removed mechanically.



Watts recommends sanitizing the household or facility plumbing by adding 50 ppm chlorine from bleach for 12 hours and then flushing. This can be achieved by:

1. Shutdown and unplug the unit.
2. Shut off the water supply and relieve the water pressure by opening a tap.
3. Remove any pre-treatment filters from their housing and fill the housing with bleach.
4. Re-mount the housing (but not the filter) and plug in the UV-COM unit to turn it on.
5. Once unit is operating, turn on the water supply and have the water flow to all taps (hot and cold), toilets, the washing machine and other water-using appliances – the bleach must fill every inch of plumbing. The Dose Alarm may arise due to low UVT after the introduction of bleach. If this occurs, use the manual override on the optional auto shutoff valve to keep valve open during procedure. Return override to auto position afterward.
6. When you detect the odor of chlorine at each spot, turn off the water and let the bleach remain in the lines and pre-treatment device housings for at least 12 hours. Turn off the UV-COM unit during this time.
7. After the waiting period is over, plug in the unit. Once stable, flush every line for at least five minutes or until the odor of chlorine is gone. See local regulations for proper disposal of chlorine residual, especially in the case of discharge into a septic system.
8. Shut off the water supply now that the disinfection procedure is complete. Relieve water pressure by opening a tap, and return the pre-treatment filter to the housing. Allow a few days after a disinfection procedure before getting a sample since residual chlorine may affect the results.
9. Have the water tested by a local recognized testing agency prior to any water consumption. The testing should be performed on a regular basis as required by local regulations.

⚠ CAUTION

Do not allow corrosive chemicals to remain in the unit for more than 12 hours – Do not operate unit during this time period as heating the water will increase corrosive nature of chemicals.

5.7 Automatic Quartz Sleeve Cleaning Device

The self-cleaning feature of the UV-COM system involves a wiper turning inside the quartz sleeve. The wiper operates soon after power up of the lamps and then every 4 hours it will cycle for 5 minutes. The wiper can be enabled anytime in the Advanced Settings menu, item 2.2.1.2. The LED will flash quickly during a wiper cycle.

5.8 Built in Purge Valve

The UV-COM products contain a flushing or purge valve that cycles water through the unit during long periods of no water usage. The unit monitors water usage by measuring the rise in water temperature within the treatment chamber. During periods of no water flow, the purge valve on the small units can expel 1 gallon (4 liters) of water every 60-90 minutes; the largest unit can expel up to 4 gallons (15 liters). If the largest unit fails to purge and the water temperature exceeds 113°F (45°C), the unit will shut down to prevent overheating.

Section 6: Troubleshooting

The UV-COM will operate unattended until a fault arises.

If an alarm occurs, the auto shutoff valve (optional) will close, preventing water from flowing; the LED turns red; the audio alarm will beep continuously; the touchscreen turns red and displays a message; the RUN contact will open to indicate the unit is no longer treating. The fault should be corrected to return the unit to normal operation and have the water flow again.

If a warning occurs, the auto shutoff valve (optional) remains open; the LED flashes red; the audio alarm will beep once; the screen turns yellow and displays a message; the warning contact will close to indicate the unit is still treating but in an abnormal state. The warning should be addressed as soon as possible and if left unattended, could turn into an alarm.

The Message History, available in the Settings menu, item 2.6, is very useful in troubleshooting since it contains up to 100 messages/events with associated recorded data such as times, UVI, UVT, UV sensor values, and temperatures.

In the event of an alarm, in many cases, a physical inspection of the unit with the power off should be done to try to identify a cause. A slow water leak for instance, near the top of the unit could stain lamps or reflectors and may not be uncovered without a full system inspection.

Dose Alarm

The Dose Alarm occurs when there is insufficient UV dose to treat the maximum flow rate prescribed by the unit. The Dose Alarm could be a result of low UV intensity or low UV Transmittance (UVT) or a combination of both. Review both values in the System Info Menu to determine which is causing the alarm and take corrective action. It is highly recommended to have a UVT sample taken to confirm system prediction.

The Advanced Settings menu under Force Outputs conveniently provides the ability to manually turn on and off devices to confirm their operation. Devices return back to their automatic position after 10 minutes.

Cycling the power is also useful to occasionally reset the software.

Troubleshooting Guide

SYSTEM STATUS	POSSIBLE CAUSE	CORRECTIVE ACTION
No Power (LED is off, touchscreen is off)	Ground-fault circuit-interrupter (GFCI) tripped.	Check for water leaks. Reset GFCI.
	Fuse Blown.	Check for water leaks. Replace fuse (see Fig. 4.4 for fuse location)
	Touchscreen pcb not connected to power pcb.	Ensure ribbon cable is connected at both ends.
	Circuit Board is damaged.	Confirm if Power pcb has any illuminated LEDs. If so replace Touchscreen pcb (LCD).
UV Lamps not starting (occurs after 6 unsuccessful attempts)	UV Chamber interlock not engaged.	Check that each latch is correctly positioned and secure UV chamber door.
	# of lamp starts have exceeded specification.	Review Total Lamp starts in System Info Menu. Replace lamps but reduce future lamp cycles.
	UV lamp failure	Replace lamps
	UV Ballast Failure	Replace ballast
	Over temperature condition.	Either the system, pcb or water temperature has occurred. Allow to cool off and investigate cause by reviewing Message History.
UV Lamps on but UVI is low	Lamps are warming up after a power interruption.	Allow lamps up to 15 minutes to reach full power
	New LPHO lamps installed.	First time LPHO lamps are turned on it may take 3 to 4 hours to reach full power. After this initial "burn-in", warm-up time will be a few minutes.
	The UV output of the lamps have diminished.	Lamps have exceeded their lifetime. Replace lamps. # of lamp starts have exceeded specification. Replace lamps but reduce future lamp cycles.
	UV sensor requires recalibration/replacement.	Install reference sensor to confirm status of unit sensor.
	UV Lamps operating outside of recommended temperature conditions.	Check if UV blower is operating correctly.
		For cold water applications, increase room temperature or alter LPHO lamp heater settings.
Water Temperature High Warning and Alarm	Warning issued when water temperature within the UV chamber exceeds 95°F (35°C) for C403 and 104°F (40°C) for C222 and C196. Alarm issued when water temperature within the UV chamber exceeds 113°F (45°C) – UV Lamps are turned off (applies to C403 model)	Check if sufficient water pressure to operate purge valve.
		Check for blockage in purge discharge tubing.
		Check for debris in purge valve.
System Temperature High Warning and Alarm	The system temperature has exceeded a safe operating level causing the UV lamps to be turned off.	Check if water flow has been turned off.
		Check if operating temperatures have exceeded specifications.
		Check if both system blowers are operating correctly.
Circuit Board Temperature High Alarm	The temperature within the electrical chamber has exceeded a safe operating level causing the UV lamps to be turned off.	Check if operating temperatures have exceeded specifications.
		Check if the pcb blower is operating.
Wiper Not Turning Warning	The system has failed to detect wiper motion during the routine wiper cycle.	Check wiper motor operation
		Check wiper position switch and cam.

Section 7: Maintenance

Treatment of water will occur as long as the unit is properly maintained with genuine parts in accordance with these instructions. Operating a malfunctioning unit or defeating any system sensors may jeopardize the safety of the water. Online videos are available to help with typical maintenance tasks. Simple tasks such as quartz inspections and lamp replacements can be done by end-user. If more in-depth activities such as quartz replacement is required, please contact Watts technical service.

Test Shutoff Valve Monthly

The optional auto shutoff valve should be tested monthly. Unplug valve from unit to confirm water stops flowing. Plug the valve in again to confirm water continues to flow.

Clean Air Filter Periodically

The UV-COM product contains a washable air filter and it is located in the air inlet port (See Figure 7.1). Periodically check and clean the filter to ensure blower operation is not impeded.

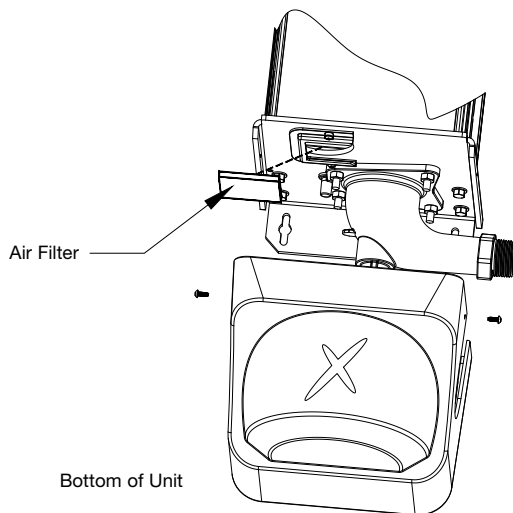

Figure 7-1

UV Sensor Maintenance

In a normal environment, it is recommended to check the UV sensor after 12-16 months of operation for any regulated site - the sensor maintenance can coincide with the UV lamp replacement. Please consult a Watts technician for further maintenance detail.

Optional UVT and Flow Meter Maintenance

Regular maintenance is recommended. Please consult a Watts technician for further maintenance detail.

7.1 Accessing the UV Chamber

CAUTION



The UV chamber can easily be opened for lamp replacement or quartz sleeve inspection without having to drain the unit and without any tools.

Always shut down and unplug the unit before accessing the UV chamber.

1. Shutdown and unplug the unit then wait 5 minutes before opening the UV chamber to allow the lamps to cool. The lamps heat up after use and can burn your skin if touched.
2. See Figure 7-2. Open the UV Chamber by undoing the over-the-center latch. Note where the latch wire engages the extrusion feature – it must be re-latched in same manner.

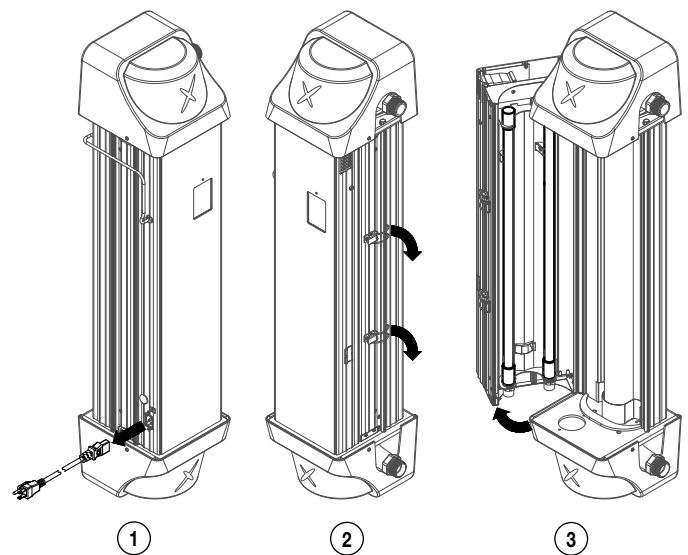

Figure 7-2

3. Slowly swing the door completely to the left to reveal the two UV lamps installed in the front half of the UV chamber. Note that the quartz sleeve can be easily inspected.
4. To close the UV chamber, swing the door back towards the back half of the UV chamber. Close all over-the-center latches ensuring the wire correctly grabs the extrusion feature.

Section 7: Maintenance

7.2 Replacing and Cleaning UV Lamps

The UV-COM contains two ultraviolet (UV) lamps that emit high-intensity UV light in the germicidal range, providing effective disinfection of legionella from the water flowing through the unit. The lamps in the unit will decay over time and they should be replaced every 12 or 16 months for optimum performance – see Product Specification Tables for lamp lifetimes. Note that lamps will only decay while in operation. Shutting down the system for seasonal use will extend lamp life.

The unit has an internal timer to keep track of the lifetime of the lamps. The UV-COM system will issue a warning when the end of lamp lifetime approaches and it will warn again when the lamp lifetime is exceeded. The amount of life remaining on the lamps is measured in days and can be seen in the Home menu.

⚠ CAUTION



Do not allow water to flow until new lamps have been installed and reach full power.

Never touch the bulb (quartz portion) of a lamp. Handle the lamp by its ends only. If the surface of the lamp becomes dusty or dirty, use a clean lint-free cloth and rubbing alcohol. For more difficult stains such as water spots, use a scale remover and rubbing alcohol to remove the stain.

NOTE: Resetting Lamp Lifetime counter will clear Lamp Starts counter and Power Ups counter. If this information is required, review it first before proceeding to Step 1.

1. Open the UV chamber as described above.
2. Use a slotted screwdriver to pry the lamps up between lamp base and ceramic socket, see Figure 7-3.
3. When the bottom pins have disengaged the socket, lift the lamp up, then swing the lamp base away from socket. Lower the lamp to disengage it from the top lamp holder. With the lamp free from the unit, carefully place it aside and remove the other lamp, see Figure 7-4.
4. Old lamps should be disposed of at a household waste management depot or transfer station; contact your local recycling and waste management authority for proper disposal procedures in your area.

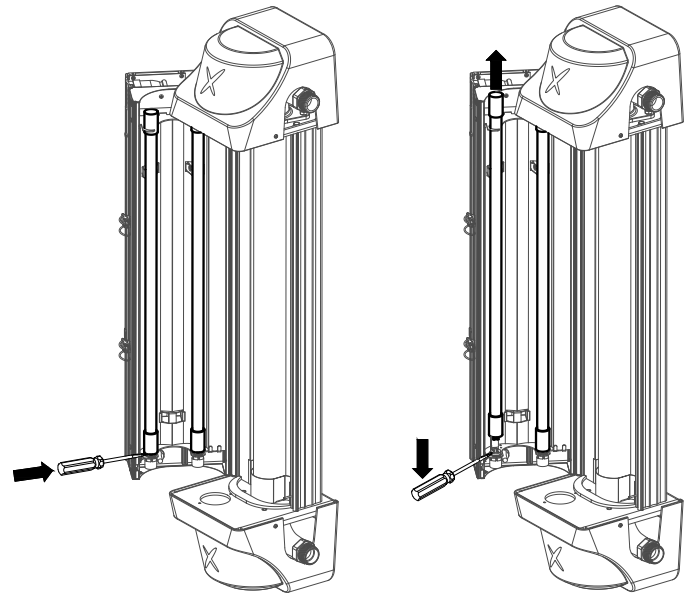

Figure 7-3

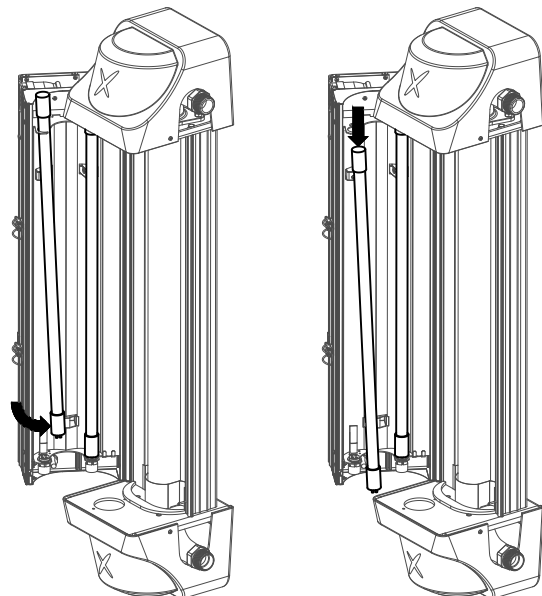

Figure 7-4

Section 7: Maintenance

5. Install the new lamps into the unit one at a time, being careful not to touch the bulb. Insert the top end of the lamp through the top lamp holder then swing lamp base in over the socket. For a LPHO lamp, rotate it until the “Stop Sign” symbol printed on the top ceramic is towards the left. See Figure 7.5. For an amalgam lamp, rotate it until the wires running down the lamp are facing the back of the unit – a check mark has been added to the top ceramic on same side as the wires. The proper orientation of the LPHO and amalgam lamp has the lamp wires opposite the UV sensors.

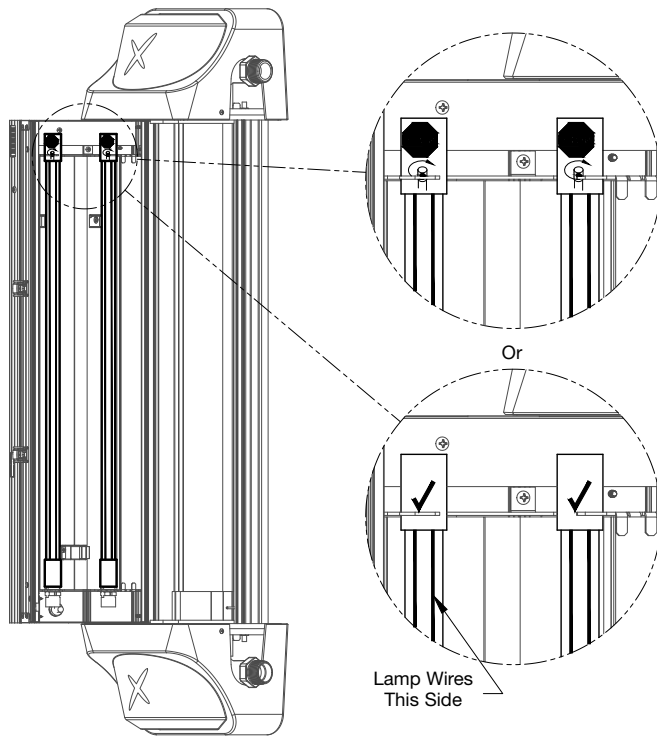

Figure 7-5

6. After the lamp has been rotated correctly, allow the 4 pins of the lamp to engage into the socket, push firmly down on the top of the lamp while holding socket. Do not twist the lamps when they are inserted. Observe the base of the lamp to confirm the pins are fully seated into the socket. Repeat for other lamp.
7. Close the UV Chamber and secure door.
8. Record the date of the lamp replacement in your Service Record Sheet.
9. Plug in the unit. The lamp lifetime counter can be reset in the Settings menu, item 2.5 (375 days for LPHO lamps, 500 days for amalgam lamps). **New LPHO lamps may take from a few moments to several hours to reach full power. Continue to operate the unit until the lamps reach full power.** The UV intensity value can be observed to confirm output levels. It is recommended for new LPHO lamps to be operated initially 3-4 hours as a burn-in to achieve lamp stability.

Section 7: Maintenance

7.3 Draining the Unit

Draining is not normally required for routine operation or lamp replacement, but it is necessary to disassemble the system, to protect against freezing, or to remove poor-quality water.

Tools Needed: Pipe wrench

1. Shut off the water supply and relieve the pressure.
2. Shutdown and unplug the unit.
3. Place a bucket under the unit to collect the water.
4. Open a tap downstream of the unit to vent.
5. Open the optional drain valve, if installed, and disconnect the flexible hose or piping at the bottom port to allow the system to drain for a few minutes. Note that the water may not flow backwards through the optional automatic valve.
6. When draining is complete, close drain valve or reconnect flexible hose or pipe connections.
7. Close any taps that were previously opened.

7.4 Cleaning the Unit

Watts UV-COM products have an automatic quartz sleeve cleaning device within the systems to virtually eliminate the disassembly and cleaning of the quartz sleeve - the quartz sleeve will remain clear and transparent as glass. If a component of the cleaning device fails, such as the wiper motor, or in extreme water cases with unique water chemistry, the quartz sleeve may become fouled and require manual cleaning. In this situation the Dose Alarm will arise and alert you to the unsatisfactory conditions. Follow the steps below to inspect the quartz sleeve and disassemble the unit for cleaning.

7.5 Determining the Need for Cleaning

1. Shutdown and unplug the unit.
2. Open the UV chamber as described in Accessing UV Chamber section.
3. Examine the quartz sleeve both inside and out – See Figure 7.2. If it is clean, no disassembly is required and the unit can be closed. Restart the unit by plugging it in.
4. If the quartz sleeve is dirty on the outside, clean with a clean lint-free cloth and rubbing alcohol.

7.6 In-place Cleaning

This procedure will clean the quartz sleeve without its removal from the unit. This is a quick and easy procedure that works well in most cases.

Tools Needed: slotted screwdriver; Phillips screwdriver; pipe wrench.

1. Fill a bucket or container with 1 gallon (4 liters) of clean water - this will be required later to clean the quartz sleeve. A squeeze bottle is useful for applying water or cleaning solution to the inside of the quartz sleeve.
2. Shutdown and unplug the unit.
3. Shut off the water supply and relieve the pressure.
4. Open the UV Chamber as described in Accessing UV Chamber section.
5. Place another bucket under the unit and drain the unit until there is about 1" (3cm) of water left in the quartz sleeve (see Draining the Unit section).
6. Disconnect the fitting at the top outlet port of the UV unit. If the stainless flexible hose was installed, disconnect the hose opposite from the UV unit then bend the open end upwards – this will make the next step easier.
7. Add about 2 oz. (60cc) of cleaning solution to the top hose/manifold. The cleaning solution can be a citric acid, vinegar or other non-hazardous solutions. Any solution used should be thoroughly rinsed out afterwards. Fill the rest of the quartz sleeve with water.
8. Let the cleaning solution remain in the quartz sleeve for at least 10-20 minutes.
9. Manually turning the wiper may greatly assist the cleaning process. To do this, remove the top plastic cover then remove the motor and turn the wiper shaft with a slotted screwdriver (counterclockwise while looking at the shaft). Leave the trigger cam of the wiper positioner switch in place.
10. Drain the unit and inspect the quartz sleeve. If clean, flush the unit with clean water. If fouling remains, repeat procedure or proceed to disassembling the unit.
11. Once the unit is clean, reassemble the system including the motor, plastic cover, top port connection(s) and UV chamber door.
12. Slowly open the water supply and check for leaks.
13. Restart the unit by plugging it in.

Section 7: Maintenance

7.7 Disassembling the Unit

NOTE: This procedure is not recommended for untrained users - please contact your certified water specialist to assist should disassembly be required.

Tools Needed:

- Slotted screwdriver
 - Philips screwdriver
 - Pipe wrench
 - 7/16" (11mm) wrench or nut driver
 - Bottle clean brush with long handle
1. Fill a bucket with 1 gallon (4L) of clean water, required later to clean the quartz sleeve. A squeeze bottle is useful for applying water or cleaning solution to the inside of the sleeve.
 2. Shutdown and unplug the unit.
 3. Shut off the water supply and relieve the pressure.
 4. Place another bucket under the unit and drain the unit completely (see Draining the Unit section). Note that piping connections to the inlet and outlet ports will have to be removed in order to disassemble the unit's stainless manifolds. Perform these disconnections now.
 5. Open the UV Chamber as described in Accessing UV Chamber section. It may be necessary to have the UV chamber door held open for this procedure.
 6. Remove top plastic cover.
 7. Disconnect wires to wiper motor, purge valve, and water temperature sensor (thermistor).
 8. Remove the wiper motor by removing the two screws holding it to the plate.

9. Remove the motor mounting plate from the top manifold by removing the two screws and nuts. Removing this plate will allow top manifold to come free from the wire bundle.

CAUTION

Do not damage sealing surfaces of manifolds or wiper shaft adapter - handle these parts with care to prevent water leaks. The wiper assembly must also be handled with care to prevent damage to cleaning edges. The wiper blades are sharp, handle them with care.

10. Remove the retaining ring (E-ring) holding the wiper shaft.
11. Use the 7/16" (11mm) wrench or nut driver to remove the four nuts of the top manifold in an alternating pattern (top left, bottom right, bottom left, then top right). The bottom manifold does not require removal to clean the quartz sleeve, so leave it in place. This will support the quartz sleeve during cleaning and simplify the overall process.
12. Press down on the wiper shaft and remove the top manifold (Figure 7.6) by lifting it straight up to disengage the wiper shaft. The shaft adapter should remain on the top of the wiper shaft. Note the orientation of the slot to the wiper blades - the slot is aligned to the wiper blades.
13. Remove the wiper assembly by carefully lifting it up and out of the quartz sleeve. Rotating it counter-clockwise as you lift will help. Prevent the shaft adapter from falling off the wiper assembly. Note that the shaft adapter sits on the top end of the wiper shaft - the top end of the shaft has a hole, the bottom end of the shaft does not.

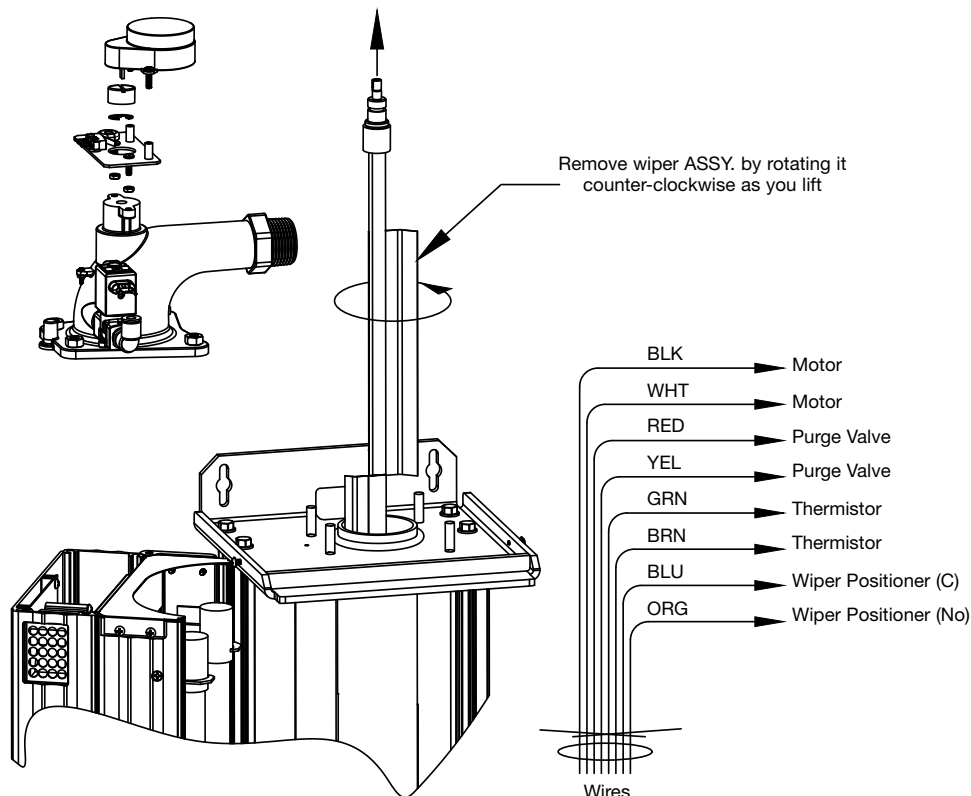

Figure 7-6

Section 7: Maintenance

7.8 Cleaning/Removing the Quartz Sleeve

1. Use a bottle cleaning brush with a long handle to scrub the inside of the quartz sleeve. Scrub and flush it with water repeatedly to clean the quartz sleeve. Use a squeeze bottle to apply water or solution to the quartz sleeve to keep the area tidy. Note: Keep the rest of the unit free from moisture. Examine the quartz sleeve.
2. If the quartz sleeve is still dirty, use a scale remover such as CLR or Lime Away and apply it to the inside of the quartz sleeve. Citric acid, available at a drug store, can also be used. Always flush with clean water afterwards.
3. Once the quartz sleeve is clean, reassemble the unit (see Figure 7.8). Replace any seals that appear to have been damaged.
4. If the quartz sleeve is still not clean, it requires replacement. This is done by removing the bottom manifold (see Figure 7.7). Replacing a quartz sleeve is easier when the unit is placed on a horizontal surface – removing the unit from the wall to work on a bench is recommended, especially for the UV-COM C403 models.

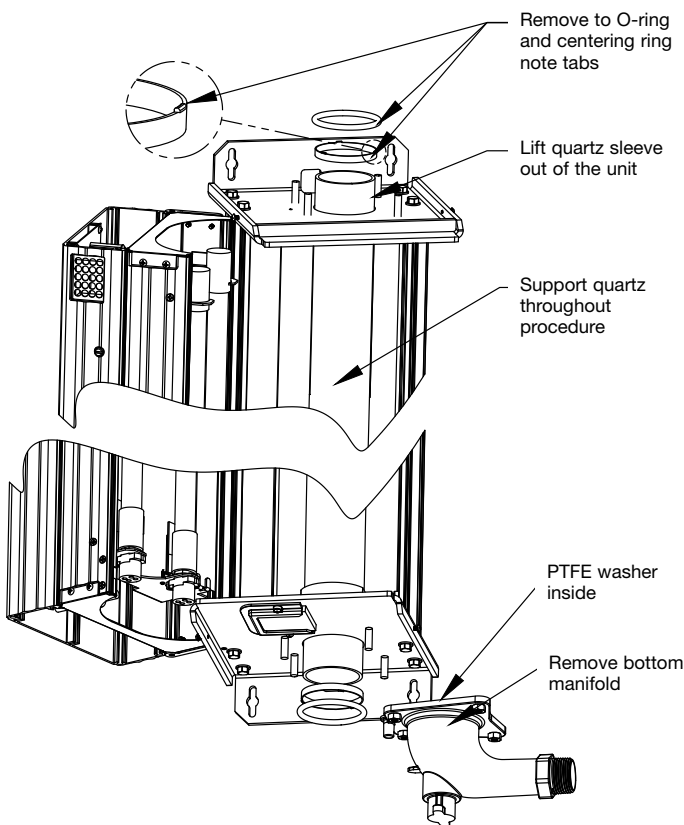

Figure 7-7

5. Remove the bottom plastic cover and then the bottom manifold by undoing the four nuts in an alternating pattern (top left, bottom right, bottom left, then top right). Do not allow the polytetrafluoroethylene (PTFE) washer at the lower cavity of the bottom manifold to fall out – the wiper shaft sits on this washer. Support the quartz sleeve as you remove this item.
6. Remove the quartz sleeve by removing the top and bottom O rings and then the quartz centering rings. Lift the quartz sleeve out of the unit.
7. Install the new quartz sleeve into the unit and center it vertically. Be careful not to chip the ends. Support the quartz sleeve for the next two actions.

8. Install the quartz centering rings (small tabs face outwards) and then the top and bottom O rings, keeping the quartz sleeve centered vertically in the unit.
9. Replace the bottom manifold (see Fig. 7.7) by installing the four nuts in an alternating pattern (top left, bottom right, bottom left, then top right). Check again for polytetrafluoroethylene (PTFE) washer.

7.9 Reassembling the Unit

1. Replace the wiper assembly carefully in the quartz sleeve-wetting the inside of the quartz sleeve with water will also make the task easier. Turn the wiper assembly counter-clockwise (looking from the top) as it is being inserted into the quartz sleeve – this will make the task easier and align the wiper blades properly. Ensure the bottom of the wiper is correctly seated into bottom manifold.

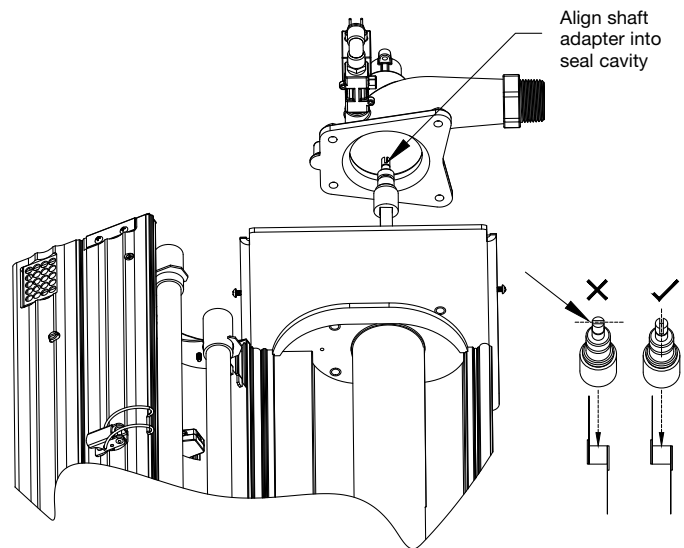

Figure 7-8

2. Ensure quartz O-ring seal is in place around quartz sleeve and then replace the top manifold by aligning the shaft adapter into the seal cavity of the top manifold (see Figure 7.8).
3. Tighten the nuts in an alternating pattern. Once top manifold is secure, replace the retaining ring on the wiper shaft. Rotate the wiper assembly to counter clockwise so the top wiper blade faces the back of the unit.
4. Reconnect both top and bottom piping connections. Close the UV Chamber door.
5. Close any taps and slowly open the water supply. Inspect for leaks. Repair any leaks if necessary before plugging in the unit.
6. Reinstall the motor mounting plate by using the trigger cam to center the plate (center hole to be concentric with wiper shaft). With the wiper blade opposite the UV sensor facing the back, the trigger cam should have the dimple in the 10 o'clock position. Install the wiper motor, then reconnect all the wires.
7. Reinstall the top and bottom plastic covers.
8. Plug in the unit. Check operation of wiper motor, purge valve and water temperature switch.
9. Make an entry in the service record to establish a cleaning schedule.

Section 7: Maintenance

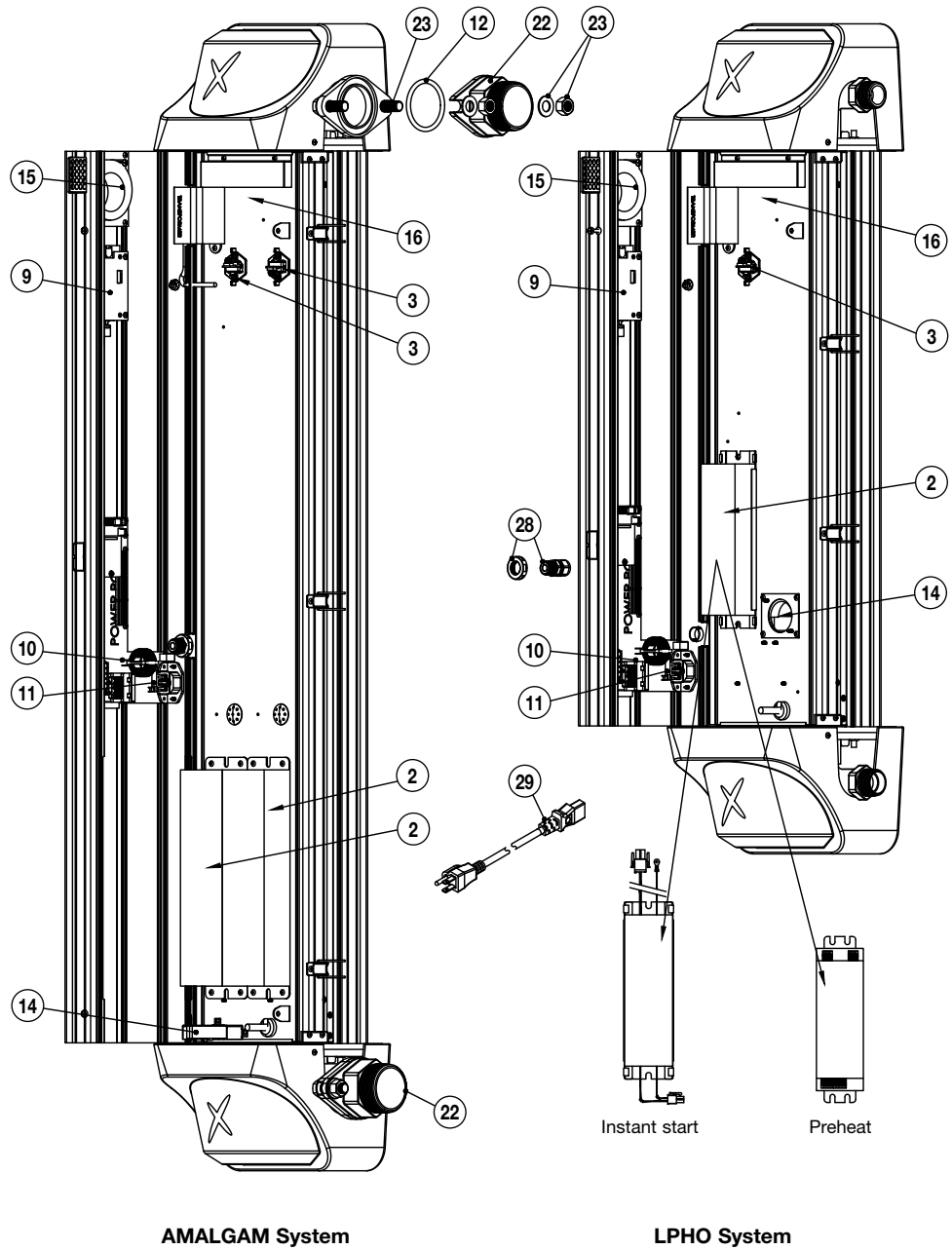

Figure 7-9B

Section 7: Maintenance

7.11 UV-COM Spare Parts List

ITEM NO.	PART NAME	MODEL		
		C403, C403M	C222, C222C, C222M, C222CM	C196, C196C, C196M, C196CM
1	UV Lamps (Shipped in pairs)	68111142 (single lamp p/n is 68111141)	68111140 (single lamp p/n is 68111139)	68111138 (single lamp p/n is 68111137)
2	Electronic Ballast	68111144 (2 per unit)	68111143	
3	UV Sensor Kit	68111145 (some units have 2 - see Product Spec. Table)		
4	Wiper Motor Kit	68111146		
5	Purge Valve Kit	68111147		
6	Quartz Sleeve Replacement Kit (includes 2 O-rings)	68111150	68111149	68111148
7	Wiper Assembly Kit	Contact Watts customer support		
8	Reflector Kit (shipped and sold in pairs)			
9	Circuit Board - LCD			
10	Circuit Board – Power	68111151 (for 120V systems)		
11	Fuse Pack (5 pcs)	Contact Watts customer support		
12	Seal Kit (complete)			
13	Air Filter			
14	UV Chamber Blower Kit			
15	Circuit Board Blower Kit			
16	Temperature Sensor (Thermistor) Kit			
17	Top Plastic Cap			
18	Bottom Plastic Cap			
19	Lamp Socket Wire Harness			
20	Top SS Manifold/ Thermistor/Purge Valve Kit			
21	Bottom SS Manifold	Contact Watts customer support		
22	2" NPT Adapter (1 pc.)			
23	Fastener Kit for 2" Adapter (2 per unit)			
24	Optional Flexible SS Hose	68111153 (2" hose)	68111152 (1" hose)	
25	Optional Auto Shut-off Valve – Nylon	Contact Watts customer support		
	Optional Auto Shut-off Valve – Brass			
26	Heaters for LPHO Lamps	Contact Watts customer support		
27	Wiper Position Switch Kit			
28	Optional Strain Relief Kit			
29	Power Cord			
-	Purge Valve Relocation Kit			
-	10gpm Flow R. Kit			
-	13.2gpm Flow R. Kit			
-	15gpm Flow R. Kit			
-	18.5gpm Flow R. Kit			
-	20gpm Flow R. Kit			
-	25gpm Flow R. Kit			
-	26.4gpm Flow R. Kit			

Section 9: Performance Data Sheets

Model:	UV-COM C196C & C196CM
Class Designation:	NSF/ANSI 55 Class A
Minimum UV Dose:	40mJ/cm ²
Operating Pressure:	34-690kPa (5-100psig)
Max. Flow Rate:	62.5 L/min, 3.7 m ³ /hr (16.5USgpm)
Pressure drop @ 46.9 L/min	156kPa (22.7psi) (12.4 US gpm)
Dimensions:	Height – 92.6cm (36.5") Width – 24cm (9.6") Depth – 21.8cm (8.6")
Inlet/Outlet Connections:	1" NPT male
Operating Temperatures:	Ambient 1-40°C (34-104°F)
Max. Feed Water temperature ¹ :	40°C (104°F)
Min. Feed Water temperature:	1°C (34°F)
Shipping Weight:	14.9kg (32.8lbs)
Input Power:	120Vac/60Hz, 196W
Lamp Lifetime	12 Months, P/N 68111137, Lamp Pair p/n 68111138

¹ Certified by WQA to 73°F or 23°C

Standard features:	Automatic quartz cleaning Built-in flow regulator Purge valve to regulate water temperature Color touchscreen for Operational data such as UV Intensity, Net UV Transmittance, Lamp Lifetime, Online Troubleshooting Dual Sensors for UV and Net UVT monitoring
Optional features:	Auto shutoff valve engineered to be failsafe 4-20mA & Modbus capability (C196CM) Stainless Flexible Hoses

The UV-COM C196C is installed indoors on a wall in a dry location. The unit should be plumbed in downstream of any pretreatment devices but upstream of distribution plumbing. Installation is quick and simple using the optional 1" flexible hoses. The UV-COM C196C plugs into a 120Vac ground-fault circuit-interrupter (GFCI).

The UV-COM C196C incorporates both audible and visual alarms to indicate system status and an optional normally closed auto shutoff valve is available to shut off the water supply in the event of a system fault. There is a color touchscreen for operational data together with a colored LED for quick status checking.

The automatic quartz cleaning feature is engineered to eliminate the periodic maintenance required by conventional UV systems. The UV lamps require replacement after 12 months of operation.

The recommended water quality parameters are:
% Transmission of Ultraviolet Light (% UVT) > 75%
Total Dissolved Solids (TDS) <= 1000 mg/L
Level of Turbidity <= 1 NTU

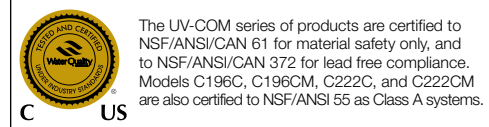

This Class A system conforms to NSF/ANSI 55: Ultraviolet Microbiological Water Treatment Systems for the disinfection of microbiologically contaminated water that meets all other public health standards. The system is not intended to convert wastewater or raw sewage to drinking water. The system is intended to be installed on visually clear water.

NSF/ANSI 55: Ultraviolet Microbiological Water Treatment Systems defines wastewater to include human or animal body waste, toilet paper, and any other material intended to be deposited in a receptacle designed to receive urine and feces (blackwaste); and other waste materials deposited in plumbing fixtures (greywaste).

If this system is used for the treatment of untreated surface waters or ground water under the direct influence of surface water, a device found to be in conformance for cyst reduction under the appropriate NSF/ANSI Standard shall be installed upstream of the system.

Produced for: Watts Regulator Co.,
815 Chestnut Street
N. Andover, MA 01845
800-659-8400

All replacement parts may be purchased through Watts.

Replacement component

PART NAME	MODEL
UV Lamps (Shipped in pairs)	68111138 (single lamp p/n is 68111137)
Electronic Ballast	68111143
UV Sensor Kit	68111145
Wiper Motor Kit	68111146
Purge Valve Kit	68111147
Quartz Sleeve Replacement Kit (includes 2 O-rings)	68111148
Circuit Board – Power	68111151
Optional Flexible SS Hose	68111152
Wiper Position Switch Kit	68111154

Section 9: Performance Data Sheets

Model:	UV-COM C222C & C222CM
Class Designation:	NSF/ANSI 55 Class A
Minimum UV Dose:	40mJ/cm ²
Operating Pressure:	34-690kPa (5-100psig)
Max. Flow Rate:	103.7 L/min, 6.2 m ³ /hr (27.4USgpm)
Pressure drop @ 78 L/min	156kPa (22.7psi) (20.6 US gpm)
Dimensions:	Height – 102.6cm (40.4") Width – 24cm (9.6") Depth – 21.8cm (8.6")
Inlet/Outlet Connections:	1" NPT male
Operating Temperatures:	Ambient 1-40°C (34-104°F)
Max. Feed Water temperature ¹ :	40°C (104°F)
Min. Feed Water temperature:	1°C (34°F)
Shipping Weight:	15.9kg (34.9lbs)
Input Power:	120Vac/60Hz, 222W
Lamp Lifetime	12 Months, P/N 68111139, Lamp Pair p/n 68111140

¹ Certified by WQA to 73°F or 23°C

Standard features: Automatic quartz cleaning
Built-in flow regulator
Purge valve to regulate water temperature
Color touchscreen for Operational data such as UV Intensity, Net UV Transmittance, Lamp Lifetime, Online Troubleshooting
Dual Sensors for UV and Net UVT monitoring

Optional features: Auto shutoff valve engineered to be failsafe
4-20mA & Modbus capability (C222CM)
Stainless Flexible Hoses

The UV-COM C222C is installed indoors on a wall in a dry location. The unit should be plumbed in downstream of any pretreatment devices but upstream of distribution plumbing. Installation is quick and simple using the optional 1" flexible hoses. The UV-COM C222C plugs into a 120Vac ground-fault circuit-interrupter (GFCI).

The UV-COM C222C incorporates both audible and visual alarms to indicate system status and an optional normally closed auto shutoff valve is available to shut off the water supply in the event of a system fault. There is a color touchscreen for operational data together with a colored LED for quick status checking.

The automatic quartz cleaning feature is engineered to eliminate the periodic maintenance required by conventional UV systems. The UV lamps require replacement after 12 months of operation.

The recommended water quality parameters are:
% Transmission of Ultraviolet Light (% UVT) > 75%
Total Dissolved Solids (TDS) <= 1000 mg/L
Level of Turbidity <= 1 NTU



The UV-COM series of products are certified to NSF/ANSI/CAN 61 for material safety only, and to NSF/ANSI/CAN 372 for lead free compliance. Models C196C, C196CM, C222C, and C222CM are also certified to NSF/ANSI 55 as Class A systems.

This Class A system conforms to NSF/ANSI 55: Ultraviolet Microbiological Water Treatment Systems for the disinfection of microbiologically contaminated water that meets all other public health standards. The system is not intended to convert wastewater or raw sewage to drinking water. The system is intended to be installed on visually clear water.

NSF/ANSI 55: Ultraviolet Microbiological Water Treatment Systems defines wastewater to include human or animal body waste, toilet paper, and any other material intended to be deposited in a receptacle designed to receive urine and feces (blackwaste); and other waste materials deposited in plumbing fixtures (greywaste).

If this system is used for the treatment of untreated surface waters or ground water under the direct influence of surface water, a device found to be in conformance for cyst reduction under the appropriate NSF/ANSI Standard shall be installed upstream of the system.

Produced for: Watts Regulator Co.,
815 Chestnut Street
N. Andover, MA 01845
800-659-8400

All replacement parts may be purchased through Watts.

Replacement component

PART NAME	MODEL
UV Lamps (Shipped in pairs)	68111140 (single lamp p/n is 68111139)
Electronic Ballast	68111143
UV Sensor Kit	68111145
Wiper Motor Kit	68111146
Purge Valve Kit	68111147
Quartz Sleeve Replacement Kit (includes 2 O-rings)	68111149
Circuit Board – Power	68111151
Optional Flexible SS Hose	68111152
Wiper Position Switch Kit	68111154

Section 10: WQA Statement



The UV-COM series of products are certified to NSF/ANSI/CAN 61 for material safety only, and to NSF/ANSI/CAN 372 for lead free compliance. Models C196C, C196CM, C222C, and C222CM are also certified to NSF/ANSI 55 as Class A systems.

This Class A system conforms to NSF/ANSI 55: Ultraviolet Microbiological Water Treatment Systems for the disinfection of microbiologically contaminated water that meets all other public health standards. The system is not intended to convert wastewater or raw sewage to drinking water. The system is intended to be installed on visually clear water.

NSF/ANSI 55: Ultraviolet Microbiological Water Treatment Systems defines wastewater to include human or animal body waste, toilet paper, and any other material intended to be deposited in a receptacle designed to receive urine and feces (blackwaste); and other waste materials deposited in plumbing fixtures (greywaste).

If this system is used for the treatment of untreated surface waters or ground water under the direct influence of surface water, a device found to be in conformance for cyst reduction under the appropriate NSF/ANSI Standard must be installed upstream of the system.

Section 11: Watts UV-COM Limited Warranty

Limited Warranty for Watts UV-COM Ultraviolet Water Disinfection Systems purchased in North America.

What this warranty covers:

Defects in materials and workmanship in systems sold by Watts including replacement UV lamps and other original equipment manufacturer components such as manifolds or NEMA cabinets sold or certified by Watts.

What the period of coverage is for System Parts:

Five-year Limited Warranty for structural, hardware, and mechanical components. Specifically, this includes the following system parts: system casing (machined and extruded aluminum parts, stainless steel parts, and plastic molded components), stainless steel manifolds, NEMA cabinets, welded steel skids and structural components, and stainless steel self-cleaning mechanism.

Three-year Limited Warranty for electrical components, reflectors, and quartz sleeve. Specifically, this includes the following system parts: wiper motor, air blowers, circuit boards, ballast and micro-processor with digital display, wiring harnesses, lamp sockets, reflectors, and quartz sleeves.

One-year Limited Warranty sensor probes and purge valves. Specifically this includes the following system parts: UV sensors and the circuit board they are mounted in, temperature probes, and purge valves.

12-month Limited Warranty for all replacement LPHO lamps (coverage applies up to two years from the date of manufacture of the lamps).

16-month Limited Warranty for all replacement amalgam lamps

Ninety-day Limited Warranty or Balance of Original Warranty for replacement Parts. Specifically this includes any system parts replaced or repaired under this Limited Warranty. This warranty period is for the balance of the original warranty or for 90 days from the date the Part is repaired and/or returned to the first end-user whichever is longer. An exception is all replacement lamps that are covered for 12 or 16 months from date of replacement depending on lamp type.

Who is covered:

This Limited Warranty extends to you only if you are the **FIRST END-USER PURCHASER and with respect to the ORIGINAL INSTALLATION; the warranty period shall commence upon the Date of Purchase.**

What we will do to correct problems covered by this Limited Warranty:

During the warranty period, as set out above, Watts will repair or replace Products or Parts, at its sole discretion and cost, with the exception of shipping and handling charges. Watts may require that certain failed part be returned to Watts within 45 days for analysis and to facilitate continuous improvement; for example, circuit boards and sensors that fail must be returned to Watts. Replacement parts or systems may be functionally equivalent reconditioned/refurbished/pre-owned or new products or parts at Watts' sole discretion. Watts may provide software updates, at its discretion, but is under no obligation to do so.

How to get help:

Call a Watts representative 1-800-659-8400.

Section 11: Watts UV-COM Limited Warranty

What this Limited Warranty does NOT cover:

Maintain your original PROOF OF PURCHASE. Watts or its representatives reserve the right to deny warranty coverage if you cannot provide proof of original purchase including date of purchase, who you purchased the Product or Part from, and serial number.

USE OF REPLACEMENT UV LAMPS THAT ARE NOT ORIGINAL EQUIPMENT SOLD BY WATTS WILL VOID THIS WARRANTY.

USE OF REPLACEMENT UV LAMPS THAT ARE NOT ORIGINAL EQUIPMENT SOLD BY WATTS WILL INVALIDATE CERTIFICATION TO OR BY EPA, WQA, MENV, NWRI AND OTHER VALIDATION PROTOCOLS AND CERTIFYING BODIES.

All UV lamps lose power over their usable lifetime; original equipment UV-COM lamps are engineered and tested to ensure that all of our systems achieve the minimum power for disinfection specified, at the end of lamp life. Lamps that are not sold by Watts may not meet those same high standards. NON-ORIGINAL EQUIPMENT UV LAMPS have not been approved by certifying bodies, thereby invalidating those tests and certifications. If you have a question as to whether lamps are original equipment, please call our Toll-Free Customer Service line at: 1-800-659-8400.

Watts may source and supply equipment that is manufactured and warranted by other companies (the Original Equipment Manufacturer) and offered as options in conjunction with Watts Products and Parts. For example: heaters or AC units used in NEMA cabinets, auto shut-off valves, stainless flexible hoses, filter housings and inserts, UPS power supplies, and on-line instrumentation or web-enabling communications equipment. **Warranties for those components are solely the responsibility of the Original Equipment Manufacturer, and NOT Watts.**

Watts is not responsible for Parts or Products that are improperly installed, used and/or not maintained as set out in this IOM or as expressly advised by Watts. This Limited Warranty does not cover damage caused by accidents, acts of God, minor scratches or imperfections and normal wear and tear. This Limited Warranty is void if the Product is improperly installed, used in conditions that exceed by Watts' specifications as set out in this IOM or Product Specifications, or if there is water damage due to improper installation or poorly or improperly tightened plumbing connections. This Limited Warranty is void if the Product or Parts have been altered or modified in any way by anyone other than a Watts representative. Warranty coverage may be void if the Product is operated in combination with ancillary or peripheral equipment not approved by Watts for use with the Products.

This Limited Warranty excludes the cost of labor in removing and/or reinstalling any defective Product or Part. In the event that a Product is returned to Watts for repair or replacement under the terms of this Limited Warranty, the Product must be returned in its original shipping container and packaging. Watts will not be liable for damage to the Product during shipping otherwise.

Watts does not assume any liability for personal injury or property damage caused by the use or misuse of any Product or Part. Watts is not liable for special, incidental, indirect or consequential damages. Watts's liability is limited to repair or replacement of the defective Part or Product and this liability shall terminate upon the expiration of the applicable warranty period as set out above.

This Limited Warranty may be amended or changed at any time, at Watts' sole discretion, without notice.

TO THE EXTENT PERMITTED BY APPLICABLE CONSUMER PROTECTION LAWS, ANY WARRANTIES PROVIDED FOR HEREIN ARE IN LIEU OF ANY OTHER WARRANTY, AND ALL OTHER WARRANTIES ARE HEREBY DISCLAIMED, WHETHER EXPRESS OR IMPLIED.

The information contained in this document is subject to change without notice. Watts shall not be liable for errors contained herein or for consequential damages from improper installation or operation of this unit.

Watts Regulator, Co
815 Chestnut Street
N. Andover MA, 01845



USA: T: (800) 659-8400 • N. Andover, MA 01845 • Watts.com
Canada: T: (888) 208-8927 • Burlington, ON L7L 5H7 • Watts.ca
Latin America: T: (52) 55-4122-0138 • Watts.com

