

Installation, Operation and Maintenance Manual

Smart Heat Pump Control 291



WARNING

 Please read carefully before proceeding with installation. Your failure to follow any attached instructions or operating parameters may lead to the product's failure.

THINK SAFETY FIRST

Keep this Manual for future reference.



Table of Contents

Important Safety Information	3	Sequence of Operation	37
Radio Frequency Statement	4	System Overview	37
Installation	5	Calls	38
Installation Location	5	2-Pipe Operation.	39
Wiring Schematic	6	4-Pipe Operation.	40
Wiring Instructions	7	Diverting Valve Operation	41
Testing the Sensor Wiring	10	Loops	41
User Interface	16	DHW Tank Operation	42
Power On	16	Heat Pump Operation	43
Lock Screen	16	Pump Operation	47
Home Screen	17	Troubleshooting	48
Status Icons	17	Errors and Alerts (1 of 7)	48
Tanks Screen	18	Errors and Alerts (2 of 7)	49
Heat Pump Screen	18	Errors and Alerts (3 of 7)	50
Boiler Screen	19	Errors and Alerts (4 of 7)	51
Mixing Screen	19	Errors and Alerts (5 of 7)	52
Pumps Screen	19	Errors and Alerts (6 of 7)	53
Charts Screen	20	Errors and Alerts (7 of 7)	54
System Inputs Screen.	20	Technical Data	56
Special Conditions	21	Limited Warranty and Product Return Procedure	56
Menu Screen	21		
Navigation.	22		
Menus	22		
Settings (1 of 10).	22		
Settings (2 of 10).	23		
Settings (3 of 10).	24		
Settings (4 of 10).	25		
Settings (5 of 10).	26		
Settings (6 of 10).	27		
Settings (7 of 10).	28		
Settings (8 of 10).	29		
Settings (9 of 10).	30		
Settings (10 of 10).	31		
Schedule Menu.	32		
Notifications Menu	33		
Overrides Menu	34		
About Menu	35		
Help Menu	36		
Registering to Nexa	36		

Important Safety Information

⚠ WARNING

It is your responsibility to ensure that this control is safely installed according to all applicable codes and standards. tekmar® is not responsible for damages resulting from improper installation and/or maintenance.

To avoid serious personal injury and damage to the equipment:



- Read Manual and all product labels BEFORE using the equipment. Do not use unless you know the safe and proper operation of this equipment.



- Keep this Manual available for easy access by all users.
- Replacement Manuals are available at tekmarControls.com



This is a safety-alert symbol. The safety alert symbol is shown alone or used with a signal word (DANGER, WARNING, or CAUTION), a pictorial and/or a safety message to identify hazards.

When you see this symbol alone or with a signal word on your equipment or in this Manual, be alert to the potential for death or serious personal injury.



This pictorial alerts you to electricity, electrocution, and shock hazards.



Double insulated.

⚠ WARNING

This symbol identifies hazards which, if not avoided, could result in death or serious injury.

⚠ CAUTION

This symbol identifies hazards which, if not avoided, could result in minor or moderate injury.

NOTICE

This symbol identifies practices, actions, or failure to act which could result in property damage or damage to the equipment.

⚠ WARNING

- It is the installer's responsibility to ensure that this control is safely installed according to all applicable codes and standards.
- Improper installation and operation of this control could result in damage to the equipment and possibly even personal injury or death.
- This control is not intended for use as a primary limit control. Other controls that are intended and certified as safety limits must be placed into the control circuit.

NOTICE

Do not attempt to service the control. There are no user serviceable parts inside the control. Attempting to do so voids warranty.

Radio Frequency Statement

This equipment has been tested and found to comply with the limits for a Class A digital device, pursuant to part 15 of the FCC Rules. These limits are designed to provide reasonable protection against harmful interference when the equipment is operated in a commercial environment. This equipment generates, uses, and can radiate radio frequency energy and, if not installed and used in accordance with the instruction manual, may cause harmful interference to radio communications. Operation of this equipment in a residential area is likely to cause harmful interference in which case the user will be required to correct the interference at his own expense.

This device complies with part 15 of the FCC Rules and with Industry Canada license-exempt RSS standard(s). Operation is subject to the following two conditions: (1) this device may not cause harmful interference, and (2) this device must accept any interference received, including interference that may cause undesired operation.

The antenna used for this radio must be properly installed and maintained and must provide a separation distance of at least 7.9 inches (20 cm) from all persons.

Changes or modifications not expressly approved by the party responsible for compliance could void the user's authority to operate the equipment.

Le présent appareil est conforme aux CNR d'Industrie Canada applicables aux appareils radio exempts de licence. L'exploitation est autorisée aux deux conditions suivantes:

(1) l'appareil ne doit pas produire de brouillage, et

(2) l'utilisateur de l'appareil doit accepter tout brouillage radioélectrique subi, même si le brouillage est susceptible d'en compromettre le fonctionnement.

Installation

Installation Location

When choosing the location for the control, consider the following:

- Keep dry. Avoid potential leakage onto the control.
RH \leq 90% to 104°F (40°C).
Non-condensing environment.
- Do not expose to operating temperatures beyond 32-104°F (0-40°C)
- Provide adequate ventilation.
- Keep away from equipment, appliances or other sources of electrical interference.
- Provide easy access for wiring, viewing, and adjusting the display screen.
- Mount approximately 5 ft. (1.5 m) off the finished floor.
- Locate the control near pumps and/or zone valves if possible.
- Provide a solid backing to mount the enclosure to. For example: plywood, studs, etc
- Use the conduit knockouts provided on the upper, lower, back and sides of the enclosure.

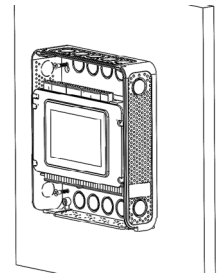
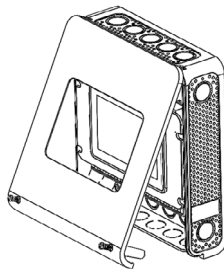
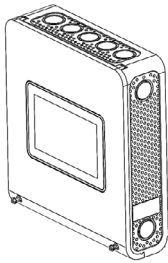

Use a Phillips screwdriver to loosen the two screws on the cover.

Pull the front cover towards you. The top of the cover will pivot on a hinge. Remove the cover by releasing the pivot hooks on the underside of the control.

Mount the enclosure to a wall using #6 wood screws in the four mounting holes. Use screw anchors if drilling into masonry.

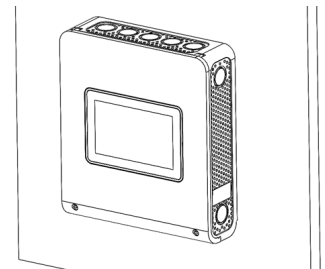
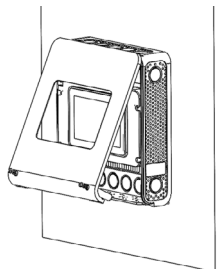
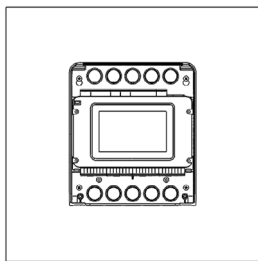

Use the 24 knock-outs to install connecting conduits and cabling to the control.

To install the cover, hook the top of the cover to the enclosure, then pivot the bottom to shut.

Use a Phillips screwdriver to fasten the two bottom screws.

Wiring Schematic

This section provides a wiring schematic for the control.

⚠ WARNING

- Before wiring, ensure all power is turned off and take all necessary precautions.
- Sensor wiring may be extended to a total length of 500 feet (152 m) using 18 AWG solid conductor wire.
- Strip all wiring to a length of 3/8 in. or 10 mm for all terminals.
- A circuit breaker or power disconnect that provides power to the control should be located nearby and clearly labeled.
- Refer to the current and voltage ratings at the back of this brochure before connecting devices to this control.
- Only qualified personnel should install or service the control.

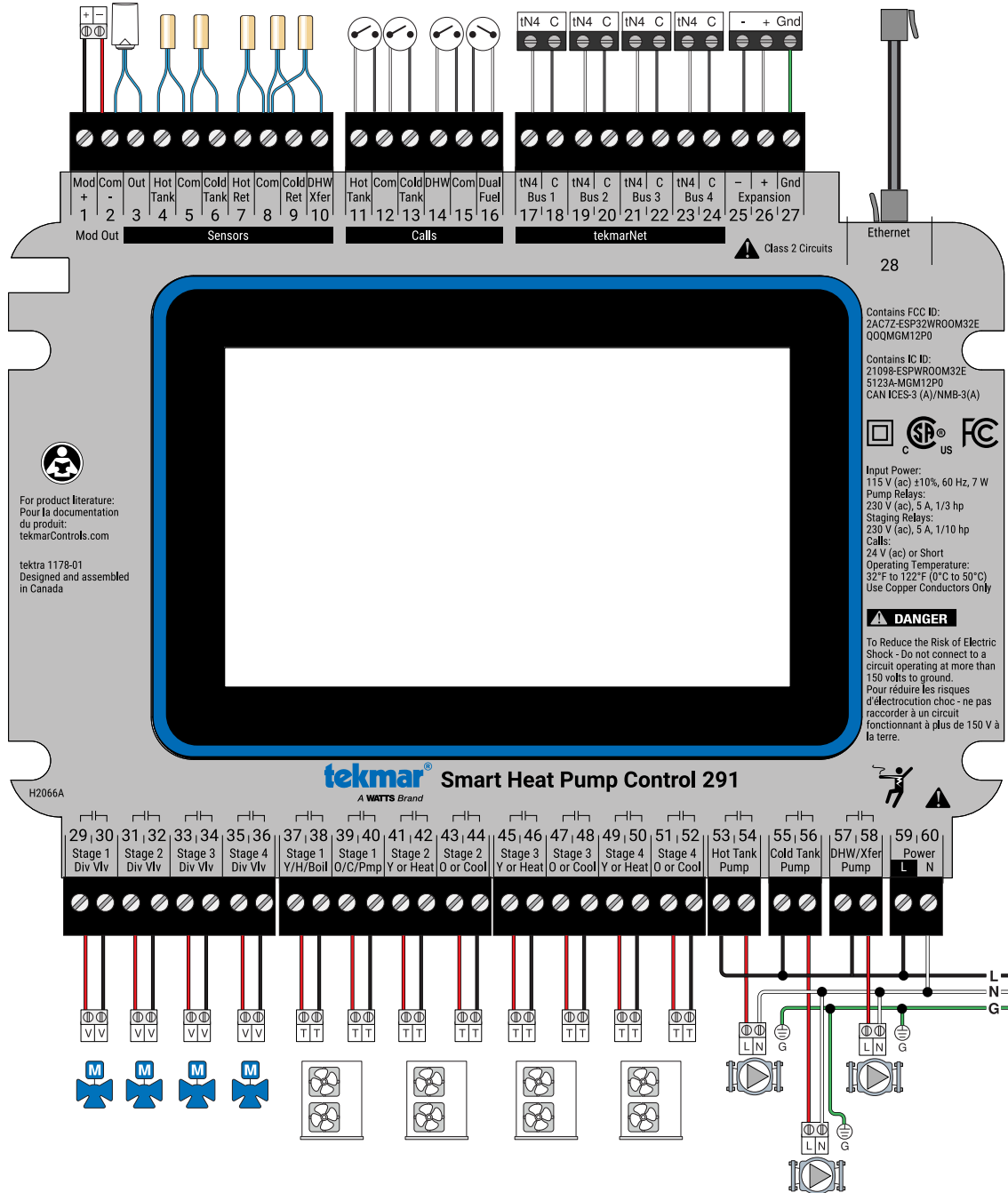

Wiring Instructions

This section explains how to wire individual devices to the Smart Heat Pump Control 291.

Outdoor Sensor 070 (Terminals 2, 3)

- The 070 can be mounted directly onto a wall with the wiring entering through the back or bottom of the enclosure. Do not mount the 070 with the conduit knockout facing upwards as rain could enter the enclosure and damage the sensor.
- In order to prevent heat transmitted through the wall from affecting the sensor reading, it may be necessary to install an insulating barrier behind the enclosure.
- The 070 should be mounted on a wall which best represents the heat load on the building (a northern wall for most buildings and a southern facing wall for buildings with large south facing glass areas). The 070 should not be exposed to heat sources such as ventilation or window openings.
- The 070 should be installed at an elevation above the ground that will prevent accidental damage or tampering.

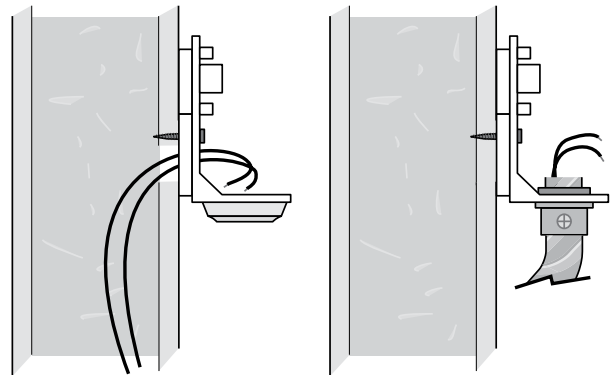
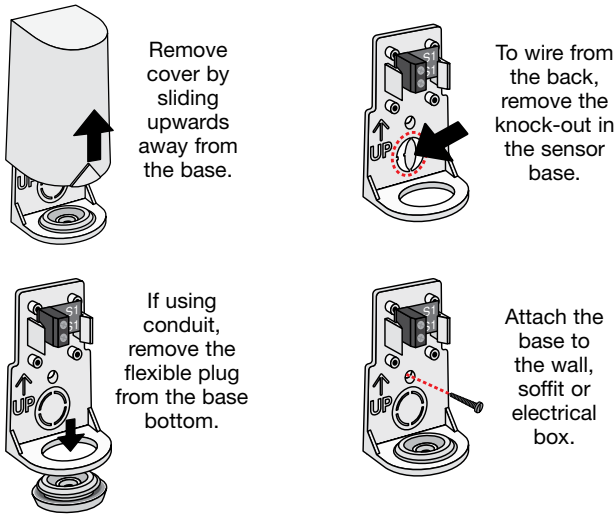

- Connect 18 AWG or similar wire to the two terminals provided in the enclosure and run the wires from the sensor to the control. Do not run the wires parallel to telephone or power cables. If the sensor wires are located in an area with strong sources of electromagnetic interference (EMI), shielded cable or twisted pair should be used or the wires can be run in a grounded metal conduit. If using shielded cable, the shield wire should be connected to the Com terminal on the control and not to earth ground.
- Replace the cover of the sensor enclosure.
- Connect the 2 wires from the outdoor sensor to the Out Sens terminals on the 291 (terminals 2 and 3).

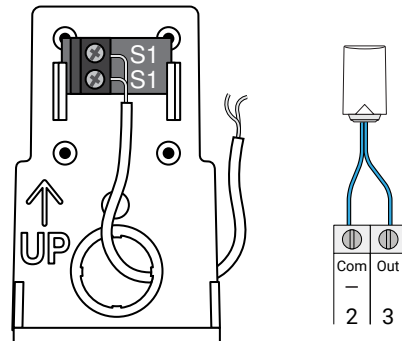

Mounting the Universal Sensors

These sensors are designed to mount on a pipe or in a temperature immersion well.

The Universal Sensor should be placed downstream of a pump or after an elbow or similar fitting. This is especially important if large diameter pipes are used as the thermal stratification within the pipe can result in erroneous sensor readings. Proper sensor location requires that the fluid is thoroughly mixed within the pipe before it reaches the sensor.

Strapped to Pipe

The Universal Sensor can be strapped directly to the pipe using the cable tie provided. Insulation should be placed around the sensor to reduce the effect of air currents on the sensor measurement.

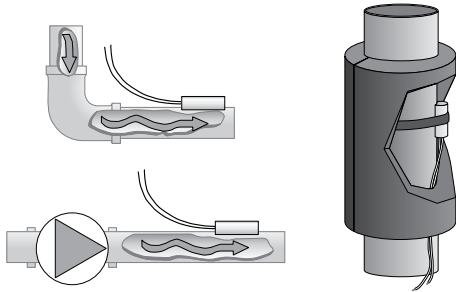

Immersion Well

If a Universal Sensor is mounted onto 1" diameter L type copper pipe, there is approximately an 8 second delay between a sudden change in water temperature and the time the sensor measures the temperature change. This delay increases considerably when mild steel (black iron) pipe is used. In general, it is recommended that a temperature well be used for steel pipe of diameter greater than 1 1/4". Temperature wells are also recommended when large diameter pipes are used and fluid

stratification is present. If the well is not a snug fit on the sensor tube, use the heat transfer paste. Apply paste to the sides of the sensor and place a pea-sized globule on the sensor tip. Push the sensor into the well and when it bottoms out, press firmly. The paste will be forced up the sides of the well.

Conduit Connection

The Universal Sensor and Universal Sensor Enclosure 080 (sold separately) are specifically designed to mount onto a 3/8" ID temperature well that is supplied with an end groove. To install the well, plumb a 'tee' into the pipe and fix the well into the 'tee'. The 080 enclosure has a 7/8" back knockout that must be removed and fitted over the temperature well. The Universal Sensor is then inserted into the well and the retaining clip supplied with the enclosure is snapped onto the well end groove. If the well has a threaded end, the installer must supply a standard threaded conduit retaining ring. The two wires from the sensor are connected to the terminal block provided in the enclosure. The other side of the terminal block is used to connect wires from the control.

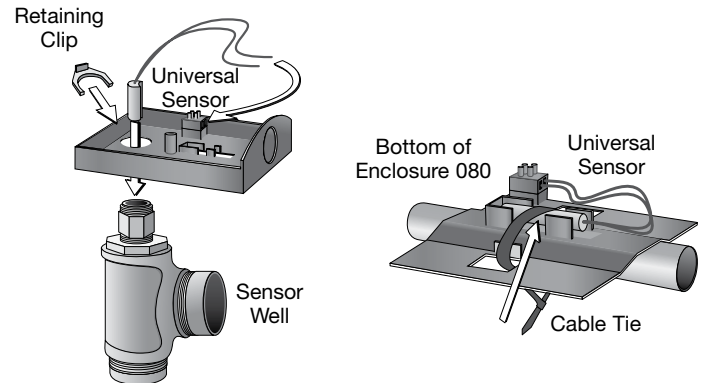

Hot Tank Sensor (Terminals 4,5)

The included Universal Sensor 082 measures the supply temperature of water coming from the hot buffer tank. The sensor can be located in the buffer tank temperature well or strapped to the system supply pipe using a cable tie.

- Connect the wires to the hot tank sensor terminals 4 and 5

In a 2-pipe system use the connections for the Hot Tank Sensor for the Tank Sensor.

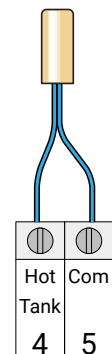

Cold Tank Sensor (Terminals 5,6)

The included Universal Sensor 082 can measure the supply temperature of water coming from the cold buffer tank. The sensor can be located in the buffer tank temperature well or strapped to the system supply pipe using a cable tie.

- Connect the wires to the cold tank sensor terminals 5 and 6

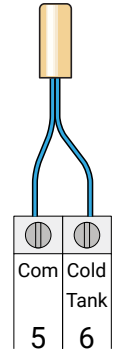

Hot Tank Return Sensor (Terminals 7,8)

The included Universal Sensor 082 measures the supply temperature of water coming from the hot buffer tank. The sensor can be strapped to the system return pipe using a cable tie.

- Connect the wires to the hot ret sensor terminals 7 and 8

In a 2-pipe system use the connections for the Hot Tank Return Sensor for the Tank Return Sensor.

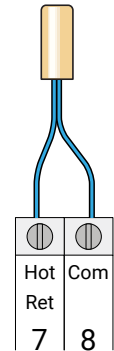

Cold Tank Return Sensor (Terminals 8,9)

The included Universal Sensor 082 can measure the supply temperature of water coming from the cold buffer tank. The sensor can be strapped to the system return pipe using a cable tie.

- Connect the wires to the cold ret sensor terminals 8 and 9

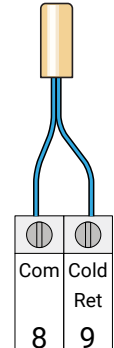

DHW/Transfer Sensor (Terminals 8,10)

A DHW sensor is used to measure the temperature of a DHW tank. For indirect DHW heating, the DHW sensor can be used instead of a DHW aquastat. For direct DHW heating, only the DHW sensor can be used to control the temperature of the DHW tank. The DHW Sensor 078 is sold separately.

If you are using the Smart Boiler Control 294 (sold separately) to control a separate boiler loop you can use a Universal Sensor 082 (sold separately) to monitor the water temperature transferring to the Heat Pump Loop.

The transfer sensor must be used if the transfer from the boiler loop is on the tank loop distribution system.

- Connect the wires to the DHW/Transfer sensor terminals 8 and 10.

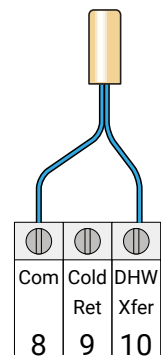

Testing the Sensor Wiring

A good quality test meter capable of measuring up to 5,000 k Ω (1 k Ω = 1000 Ω) is required to measure the sensor resistance. In addition to this, the actual temperature must be measured with either a good quality digital thermometer, or if a thermometer is not available, a second sensor can be placed alongside the one to be tested and the readings compared.

First measure the temperature using the thermometer and then measure the resistance of the sensor at the control. The wires from the sensor must not be connected to the control while the test is performed. Using the chart below, estimate the

temperature measured by the sensor. The sensor and thermometer readings should be close. If the test meter reads a very high resistance, there may be a broken wire, a poor wiring connection or a defective sensor. If the resistance is very low, the wiring may be shorted, there may be moisture in the sensor or the sensor may be defective. To test for a defective sensor, measure the resistance directly at the sensor location.

Do not apply voltage to a sensor at any time as damage to the sensor may result.

Call customer support if you need assistance with technical details.

TEMPERATURE		RESISTANCE	TEMPERATURE		RESISTANCE	TEMPERATURE		RESISTANCE	TEMPERATURE		RESISTANCE
°F	°C	Ω	°F	°C	Ω	°F	°C	Ω	°F	°C	Ω
-50	-46	490,813	20	-7	46,218	90	32	7,334	160	71	1,689
-45	-43	405,710	25	-4	39,913	95	35	6,532	165	74	1,538
-40	-40	336,606	30	-1	34,558	100	38	5,828	170	77	1,403
-35	-37	280,279	35	2	29,996	105	41	5,210	175	79	1,281
-30	-34	234,196	40	4	26,099	110	43	4,665	180	82	1,172
-25	-32	196,358	45	7	22,763	115	46	4,184	185	85	1,073
-20	-29	165,180	50	10	19,900	120	49	3,760	190	88	983
-15	-26	139,403	55	13	17,436	125	52	3,383	195	91	903
-10	-23	118,018	60	16	15,311	130	54	3,050	200	93	829
-5	-21	100,221	65	18	13,474	135	57	2,754	205	96	763
0	-18	85,362	70	21	11,883	140	60	2,490	210	99	703
5	-15	72,918	75	24	10,501	145	63	2,255	215	102	648
10	-12	62,465	80	27	9,299	150	66	2,045	220	104	598
15	-9	53,658	85	29	8,250	155	68	1,857	225	107	553

Hot Tank Call (Terminals 11,12)

A Hot Tank call is required whenever the building requires heating. The heat call can be a dry contact or up to 24 V (ac).

- Connect the Central Heat Call terminals 11 and 12 to a switched heat demand.
- Typical heat calls are from a switching relay, zone valve control or thermostat.

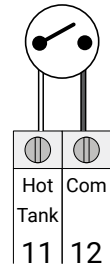

Cold Tank Call (Terminal 12,13)

A Cold Tank call is required whenever the building requires cooling. The cold call can be a dry contact or up to 24 V (ac).

- Connect the Central Cold Call terminals 12 and 13 to a switched cooling demand.
- Typical cooling calls are from a switching relay, zone valve control or thermostat.

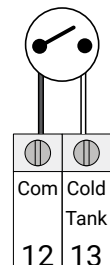

DHW Call (Terminals 14, 15)

If the DHW sensor option is not used, a call for indirect domestic hot water can come from an aquastat connected to terminals 14 and 15. The DHW Call can be a dry contact or up to 24 V (ac).

- Connect the DHW Call terminals 14 and 15 to the DHW tank aquastat.

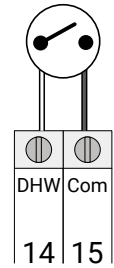

Dual Fuel Call (Terminals 15,16)

The Dual Fuel Call can be used when it is required to use an external relay to trigger shutting off the heat pumps and operating only on the backup boiler(s). The Dual Fuel Call can be a dry contact or up to 24 V (ac).

- Connect the Dual Fuel Call terminals 15 and 16 to an external relay.

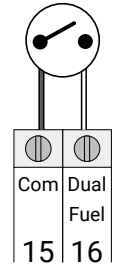

tekmarNet4 Bus (Terminals 17, 18, 19, 20, 21, 22, 23, 24)

tekmarNet4 (tN4) is a wired communication network for tekmar thermostats, setpoint controls, snow melting controls, boiler controls, and gateways. to communicate to the heat pump control. The network provides central heating calls, cooling calls, DHW calls and setpoint calls as a digital message between tekmar devices. This optimizes the heating system to operate more efficiently compared to on/off calls.

Bus 1

Bus 1 on terminals 17 and 18 connect to tekmarNet® devices that operates on the Tank loop. The connection is polarity sensitive.

Bus 2

Bus 2 on terminals 19 and 20 can be configured to be Off, the Tank or Mix 1 loops. The connection is polarity sensitive.

Bus 3

Bus 3 on terminals 21 and 22 can be configured to be Off, the Tank, Mix 1 or Mix 2 loops. The connection is polarity sensitive.

Bus 4

Bus 4 on terminals 23 and 24 can be configured to be Off, the Tank, Mix 1, Mix 2, Mix 3, or Boiler loops. The connection is polarity sensitive. Note: If connected to a Smart Boiler Control 294 it must be wired to Bus 4.

- Connect terminal 17, 19, 21, 23 (tN4) to the tN4 terminal on the device.
- Connect terminal 18, 20, 22, 24 (C) to the C terminal on the device.

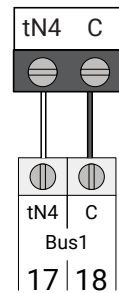

Expansion Modules (Terminals 25, 26, 27)

The control operates 4 on/off Heat Pumps and is expandable in groups of 4 up to a maximum of 16 using the Smart Heat Pump Expansion 291EXP.

Up to 3 mixing temperatures can be utilized by adding up to 3 Smart Mix Expansion 295.

The control connects to the expansion through a wired three-wire connection. The maximum bus cable length is:

100 feet (30 m) using 18 AWG solid conductor cable.

- Connect terminal 25 (-) to the expansion terminal 1 (-).
- Connect terminal 26 (+) to the expansion terminal 2 (+).
- Connect terminal 27 (Gnd) to the expansion terminal 3 (Gnd).

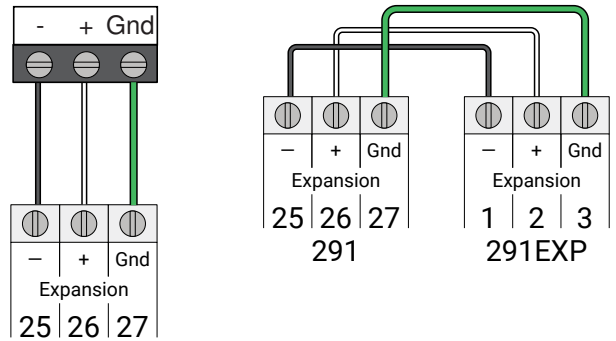

Ethernet (Terminal 28)

The control can connect to the Internet through Ethernet.

- Connect the Ethernet RJ-45 port on terminal 28 to the building Local Area Network (LAN) router or network switch using Category 5 cable.

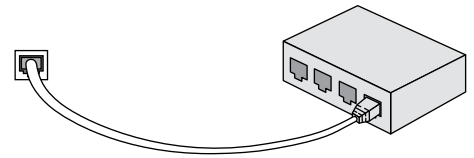

Diverting Valves (Terminals 29 to 36)

A 4-pipe system utilizes diverting valves to direct the flow of water from the Heat Pump to either the Hot or Cold Tanks. There is 1 Diverting Valve output for each Heat Pump. The Diverting Valve can be a dry contact or up to 24 V (ac).

- Connect the Diverting Valve terminals 29 and 30, 31 and 32, 33 and 34, 35 and 36 to the corresponding diverting valve.

If only one diverting valve is utilized for a group of heat pumps use Diverting Valve 1 on terminals 29 and 30.

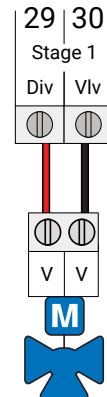

Heat Pumps (Terminals 37 to 52)

The control supports heat pumps with a compressor enable (Y terminal) and reversing valve (O or B terminal), or air source heat pumps with a heat and cool enable. Please consult your heat pump manual to determine its requirements. The contacts are compatible with heat pump inputs that are rated up to 230 V(ac), 5 A.

For 2-stage heat pumps, the second stage must follow the first stage. Example: Stage 1 and Stage 2.

Compressor and Reversing Valve

Stage 1

- Connect heat pump 1 compressor run to the Stage 1 Y terminals 37 and 38.
- Connect heat pump 1 reversing valve to the Stage 1 O terminals 39 and 40.

Stage 2

- Connect heat pump 2 compressor run to the Stage 2 Y terminals 41 and 42.
- Connect heat pump 2 reversing valve to the Stage 2 O terminals 43 and 44.

Stage 3

- Connect heat pump 3 compressor run to the Stage 3 Y terminals 45 and 46.
- Connect heat pump 3 reversing valve to the Stage 3 O terminals 47 and 48.

Stage 4

- Connect heat pump 4 compressor run to the Stage 4 Y terminals 49 and 50.
- Connect heat pump 4 reversing valve to the Stage 4 O terminals 51 and 52.

Heat and Cool

Stage 1

- Connect heat pump 1 heat to the Stage 1 heat terminals 37 and 38.
- Connect heat pump 1 cool to the Stage 1 cool terminals 39 and 40.

Stage 2

- Connect heat pump 2 heat to the Stage 2 heat terminals 41 and 42.
- Connect heat pump 2 cool to the Stage 2 cool terminals 43 and 44.

Stage 3

- Connect heat pump 3 heat to the Stage 3 heat terminals 45 and 46.
- Connect heat pump 3 cool to the Stage 3 cool terminals 47 and 48.

Stage 4

- Connect heat pump 4 heat to the Stage 4 heat terminals 49 and 50.
- Connect heat pump 4 cool to the Stage 4 cool terminals 51 and 52.

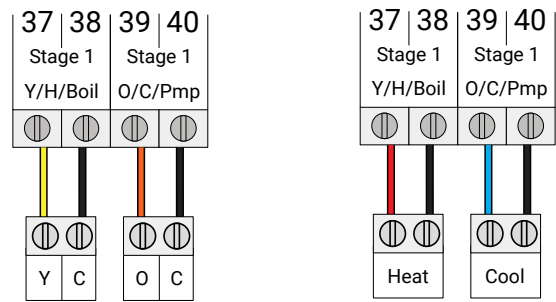

Backup Boiler (Terminals 1, 2)

A single backup boiler can be wired to the 291. For multiple boilers, a Smart Boiler Control 294 is required.

The backup boiler enable is connected to the Stage 1 boiler contact on terminals 37 and 38. The boiler pump is connected to the Stage 1 pump contact on terminals 39 and 40.

If operating a modulating backup boiler, the control provides either a 0-10 V (dc) or a 4-20 mA output to each boiler. Polarity is important.

- Connect the control Mod (+) terminals 1 to the backup boiler's analog signal input (+) respectively.
- Connect the control Mod (-) terminals 2 to the backup boiler's analog signal input (-) respectively.

Some modulating boilers may also require a boiler on/off enable signal in addition to the modulating signal. Please consult the boiler manual.

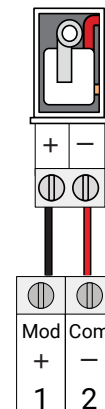

Hot Tank Pump (Terminals 53, 54)

A Hot Tank pump requiring up to 230 V (ac) 5 A, 1/3 hp can be switched through terminals 53 and 54. For simplicity in wiring and troubleshooting, a separate breaker for each pump is recommended.

- Connect the power source line wire (L) to terminal 53.
- Connect a wire from terminal 54 to the pump Line terminal.
- Connect a wire from the pump Neutral (N) back to the power source neutral.
- Ensure the system pump is connected to earth ground.

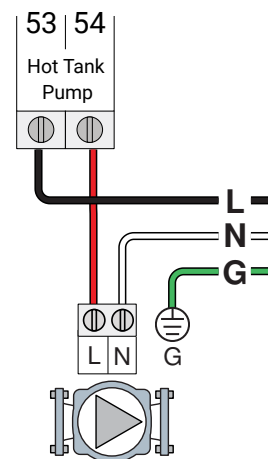

Cold Tank Pump (Terminals 55, 56)

In 2-pipe systems, the cold tank pump output is not used. The tank pump is wired to the hot tank pump output.

In 4-pipe systems, a Cold Tank pump requiring up to 230 V (ac) 5 A, 1/3 hp can be switched through terminals 55 and 56. For simplicity in wiring and troubleshooting, a separate breaker for each pump is recommended.

- Connect the power source line wire (L) to terminal 55.
- Connect a wire from terminal 56 to the pump Line terminal.
- Connect a wire from the pump Neutral (N) back to the power source neutral.
- Ensure the system pump is connected to earth ground.

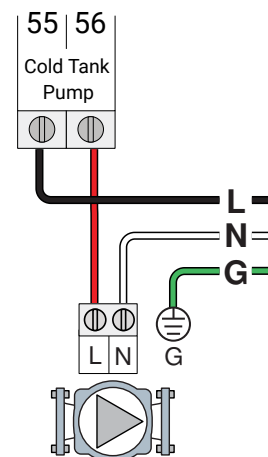

DHW Pump (Terminals 57, 58)

A DHW pump requiring up to 230 V (ac) 5 A, 1/3 hp can be switched through terminals 57 and 58. For simplicity in wiring and troubleshooting, a separate breaker for each pump is recommended.

- Connect the power source line wire (L) to terminal 57.
- Connect a wire from terminal 58 to the pump Line terminal.
- Connect a wire from the pump Neutral (N) back to the power source neutral.
- Ensure the system pump is connected to earth ground.

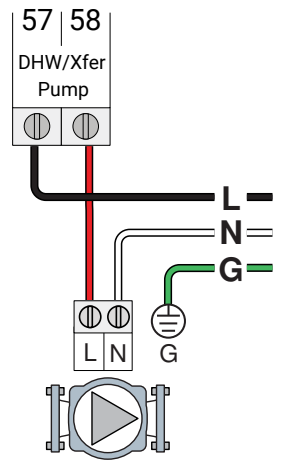

Transfer Pump (Terminals 57, 58)

When the system is using a Smart Boiler Control 294 to control a separate boiler loop a boiler loop transfer pump requiring up to 230 V (ac) 5 A, 1/3 hp can be switched through terminals 57 and 58. For simplicity in wiring and troubleshooting, a separate breaker for each pump is recommended.

- Connect the power source line wire (L) to terminal 57.
- Connect a wire from terminal 58 to the pump Line terminal.
- Connect a wire from the pump Neutral (N) back to the power source neutral.
- Ensure the system pump is connected to earth ground.

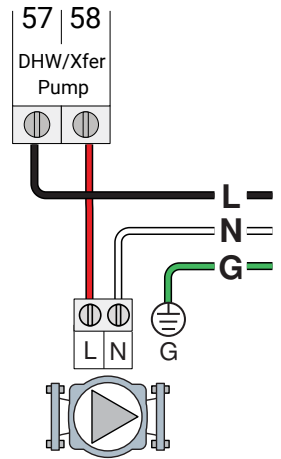

Input Power (Terminals 59, 60)

Provide a 15 Amp circuit for the input power.

- Connect the 115 V (ac) line wire (L) to terminal 59.
- Connect the neutral wire (N) to terminal 60.

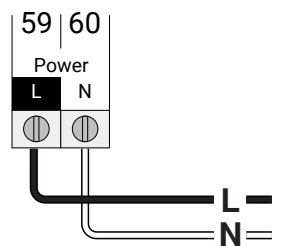

User Interface

Power On

- When first powered on, the tekmar logo appears.
- If the display does not turn on, please check the control's power source. If the issue persists please contact your tekmar sales representative or technical support for assistance.



Lock Screen

- By default, the control is not locked and does not require a passcode.
- Press "Tap to Unlock" and enter your passcode if necessary

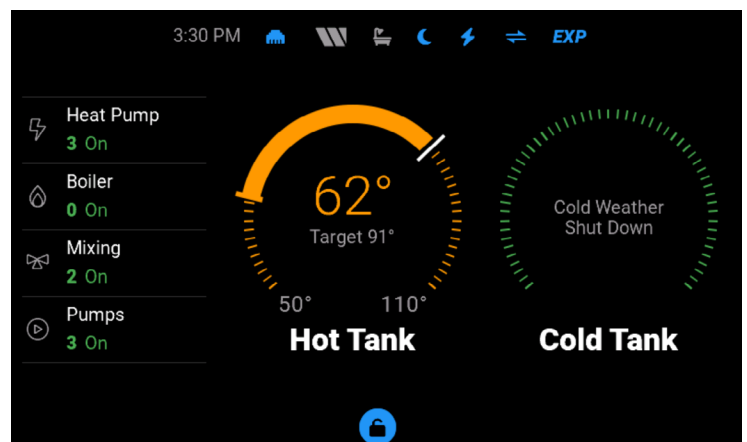





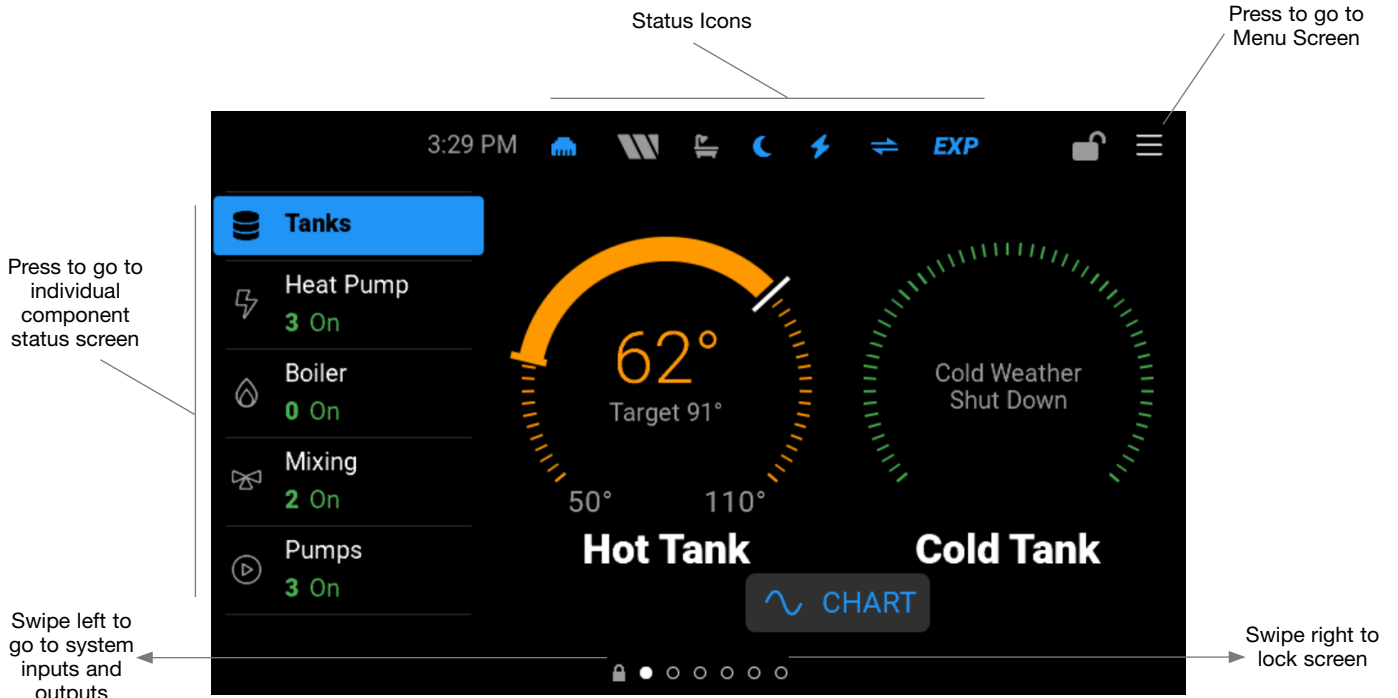



- A custom passcode can be set through the Security menu. This is an optional feature.
- If the custom passcode is lost, the master passcode is 0291.

Home Screen



Status Icons

	ETHERNET Blue indicates connection to Ethernet.		SUN When displayed, it indicates the schedule is in the occupied period.
	WI-FI Blue indicates connection to Wi-Fi.		MOON When displayed, it indicates the schedule is in the unoccupied period.
	NEXA Blue indicates connection to the Nexa cloud service.		DHW Blue indicates that there is a domestic hot water call.
	ON-PEAK When displayed, it indicates the dual fuel schedule is in the on-peak period.		NOTIFICATIONS When displayed, it indicates an error or warning notification is present.
	OFF-PEAK When displayed, it indicates the dual fuel schedule is in the off-peak period.		

Tanks Screen

- The temperature will show up in the center of the gauge.
- If there is a call there will be a target, otherwise target will show “---”.
- The target is shown as a solid white line on the gauge with a visual representation of how far the tank is from the target.
- Any additional information (status, special conditions, etc. will show in the center of the gauge.
- Click on “~Chart” to navigate to the charting screen.

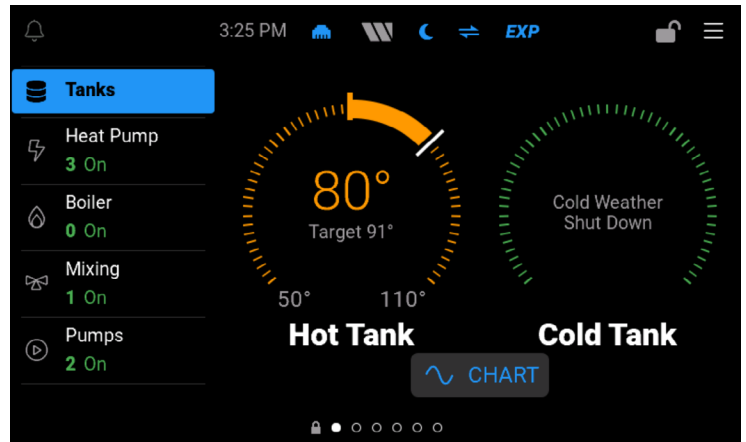

Heat Pump Screen

- The Status column indicates when the heat pump is running with a green dot.
- The Mode column indicates when the heat pump is in Heat Mode, Cool Mode, Off, or in Switchover.
- The Condition column indicates when the heat pump is not able to run due return temperature lockout, balance point or dual fuel operation.
- The Order column indicates the staging order of the heat pumps.
- Toggle to the Usage tab to view the running hours and on/off cycles of each heat pump. Reset the run time or cycle count to zero by pressing the refresh button.

The screenshot shows the 'Heat Pumps' screen with a dark theme. It features a table with columns for HP, Status, Mode, Condition, and Order. The 'Heat Pumps' section shows 3 pumps are on. The 'Usage' tab is selected.

HP	Status	Mode	Condition	Order
1	100% ●	Heat 🌡️	OK	1
2	100% ●	Heat 🌡️	OK	2
3	100% ●	Heat 🌡️	OK	3
4	Off ●	Heat 🌡️	OK	4

Boiler Screen

- The circle in blue indicates the boiler firing rate percent or boiler target temperature.
- The boiler runtime and cycles will be show here if configured to a backup boiler.
- If configured to use the Smart Boiler Control 294 the temperature and target will display.

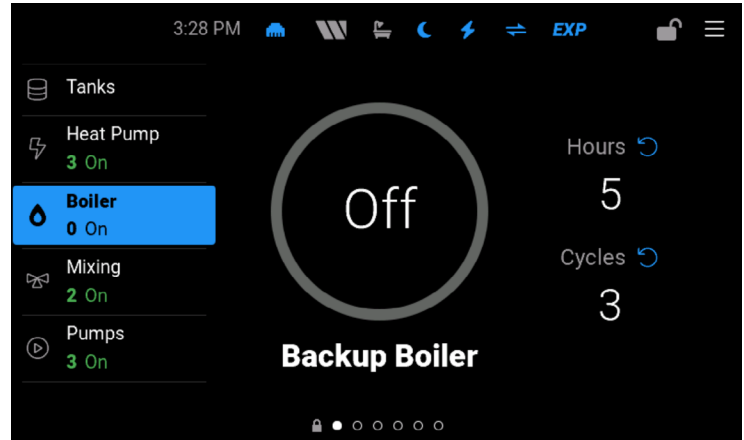

Mixing Screen

- The temperature will show up in the center of the gauge.
- If there is a call there will be a target, otherwise target will show “---”.
- The target is shown as a solid white line on the gauge with a visual representation of how far the mix temperature is from the target.
- Click on “~Chart” to navigate to the charting screen.

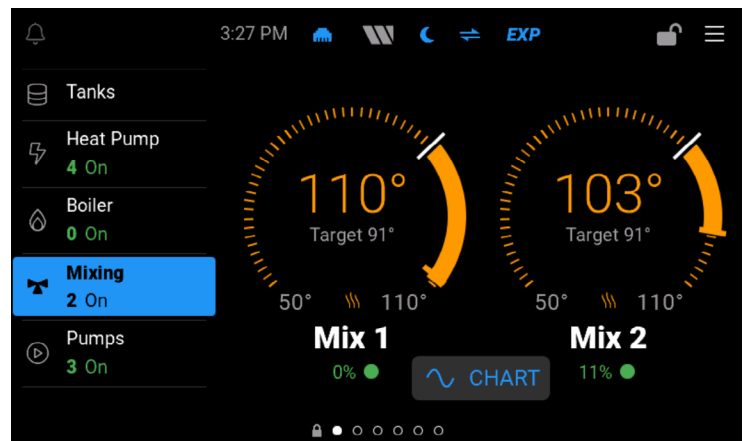

Pumps Screen

- The Status column indicates when the pump is on (green dot) or off (grey dot).
- View the hours and on/off cycles of each pump. Reset the run time or cycle count to zero by pressing the refresh button.

Pump	Status	Hours	Cycles
Hot Tank	On ●	5	4
Cold Tank	Off ●	5	2
Transfer	Off ●	5	4
Mix 1	On ●	1	3
Mix 2	On ●	0	2

Charts Screen

- View the historical charts by pressing the “~Charts” button.
- Select the loop temperature to chart by pressing the Hot Tank, Cold Tank, Mix 1, Mix 2, Mix 3 or Boiler button.
- The chart updates once per second with the newest temperature data on the right.
- The chart time span x-axis is approximately 10 minutes.
- The temperature range y-axis automatically scales based upon the min and max temperatures from the last 10 minutes.
- The target temperature is visible when the supply temperature is between the minimum and maximum temperature.

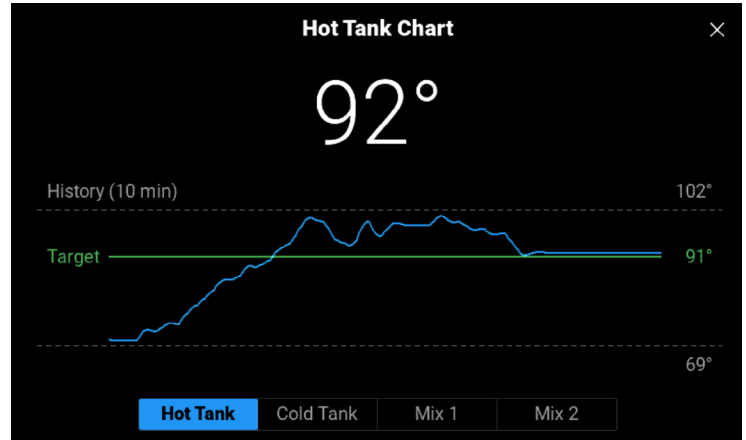

System Inputs Screen

Calls & Targets

- When a call is active the dot is green, and the target appears.
- When a call is not active the dot is grey, and the target shows “---”.
- The Domestic Hot Water target may be for either the DHW tank or the boiler supply location. This is determined by the configuration settings DHW Type and DHW Sensor.

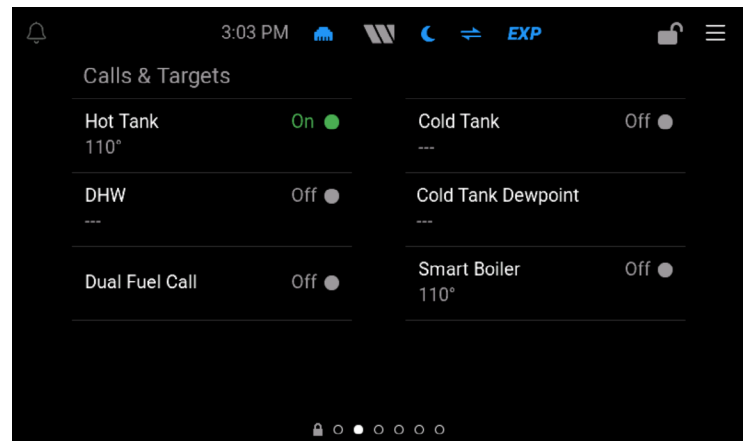

Sensors

- All of the values from the available sensors are displayed.
- The outdoor temperature can be measured by a wired sensor, through a sensor connected to a tekmarNet device or through an Internet weather service.
- The domestic hot water tank sensor is optional and is configured through the Settings > Heating Calls > Domestic Hot Water > DHW Sensor setting when DHW Type is Hot Tank Loop.

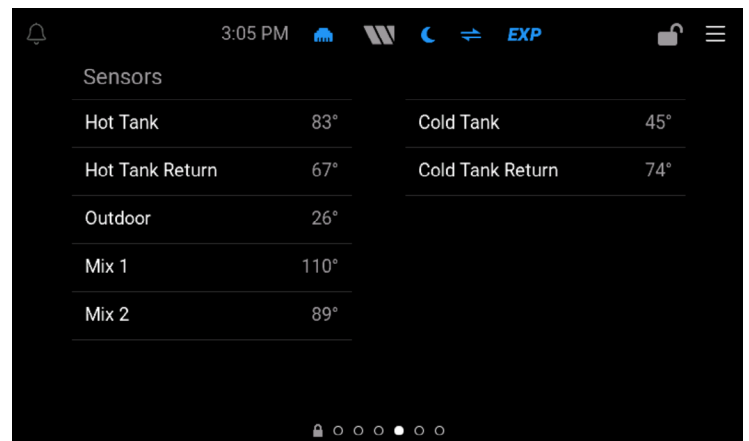

tekmarNet

- Each tekmarNet Bus 1 to 4 is mapped to a loop temperature or off.
- Each tekmarNet Bus 1 to 4 Call is shown with a green dot when active and grey when there is no call.

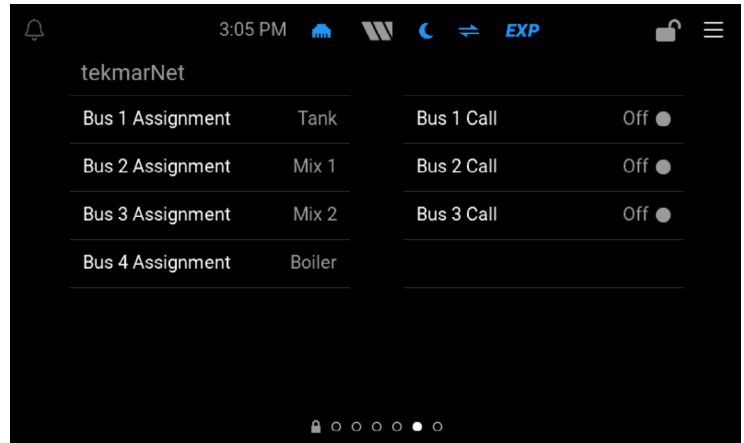

Special Conditions

- When a Special Condition is active the dot is green.
- When a Special Condition is not active the dot is grey.
- Overrides will show if a specific override is active. "Automatic" shows the control is in normal operating state.

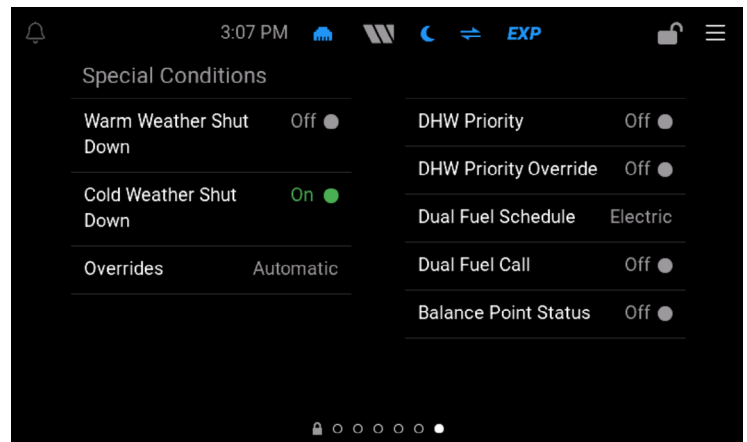

Menu Screen

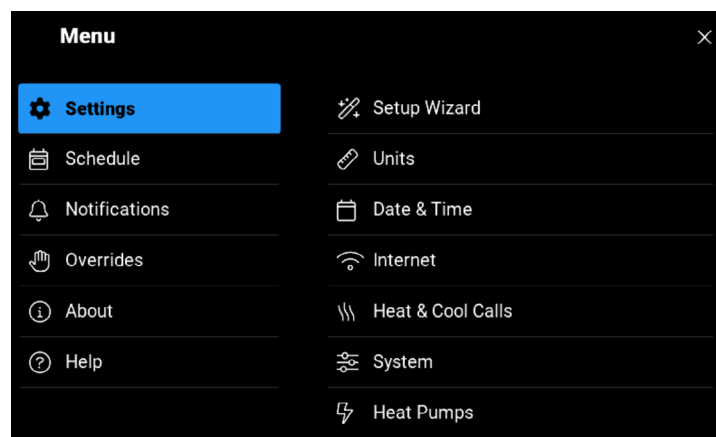

Navigation

←	BACK Go back a level without saving	SKIP	SKIP Skip step in Setup Wizard or Wi-Fi Setup
X	HOME Go to Home screen without saving	BEGIN	BEGIN Begin the Setup Wizard.
SAVE	SAVE Saves the new setting value	NEXT	NEXT Go to the next step
CLEAR	CLEAR Clears the heat pump hours or cycles to 0		

Menus

Settings (1 of 10)

Parameter	Range	Description
TEMPERATURE	°F or °C Default: °F	Units for display of temperature.
DATE AND TIME		
24-HOUR TIME	Off or On Default: Off	Selects a 24 hour time clock.
SET AUTOMATICALLY	Off or On Default: On	Automatic synchronizes the time with the Internet.
TIME ZONE	North American Time Zones Default: Eastern	Select from Newfoundland, Atlantic, Eastern, Central, Mountain, Pacific, Alaska, Hawaii time zones.
DATE	Month, Day, Year	Set the current date. Available when setting time manually.
TIME	Hours, Minutes, AM/PM	Set the current time. Available when setting time manually.
DAYLIGHT SAVINGS	Off or On Default: On	Select if daylight savings time is locally observed.
INTERNET		
CONNECTION TYPE	Off, Ethernet, Wi-Fi Default: Off	Select the Internet connection.
WI-FI NETWORK	Scans for all available networks	Select the desired Wi-Fi network SSID. Then enter the Wi-Fi password.
WI-FI SECURITY TYPE	None, WPA2-Personal, WPA2-Enterprise Default: WPA2-Personal	Select the type of Wi-Fi security. WPA2-Enterprise requires a RADIUS authentication server using PEAPv0/EAP-MSCHAPv2. This is available when setting the Wi-Fi manually. Only available when a WPA2- enterprise network is detected.
WI-FI USER	32 character name	User the WPA2-Enterprise user name. Available when configuring Wi-Fi to use WPA2-Enterprise.
WI-FI PASSWORD	32 character password	Enter the Wi-Fi password. Available when configuring a Wi-Fi network.

Settings (2 of 10)

Parameter	Range	Description
NEXA	Register or Deregister	Register the control with Nexa to use the web or mobile apps.
IP CONFIGURATION	DHCP or Static Default: DHCP	Select if the control should receive an automatic IP address from the router DHCP server or use a static IP address.
IP ADDRESS	0.0.0.0 to 255.255.255.255 Default: 192.168.0.1	Set the static IP address. Available when IP Configuration is Static.
SUBNET MASK	0.0.0.0 to 255.255.255.255 Default: 255.255.255.0	Set the static IP address. Available when IP Configuration is Static.
ROUTER	0.0.0.0 to 255.255.255.255 Default: 192.168.1.1	Set the router or gateway IP address. Available when IP Configuration is Static.
DNS 1	0.0.0.0 to 255.255.255.255 Default: 0.0.0.0	Set the control's primary DNS. 0.0.0.0 uses the factory default DNS servers.
DNS 2	0.0.0.0 to 255.255.255.255 Default: 0.0.0.0	Set the control's secondary DNS. 0.0.0.0 uses the factory default DNS servers.
HEAT & COOL CALLS > GENERAL		
HEATING OUTDOOR DESIGN TEMPERATURE	-60 to 45°F (-51.0 to 7.0°C) Default: 10°F (-12.0°C)	Set the outdoor temperature for the heating curve on the coldest day of the year.
COOLING OUTDOOR DESIGN TEMPERATURE	50 to 122°F (10.0 to 50.0°C) Default: 90°F (32.0°C)	Set the outdoor temperature for the cooling curve on the hottest day of the year.
WARM WEATHER SHUT DOWN	Off or On Default: Off	Select if the control should shut down the central heating based on the outdoor air temperature.
WARM WEATHER SHUT DOWN OCCUPIED	35 to 100°F (1.5 to 38.0°C) Default: 70°F (21.0°C)	Set the outdoor air temperature at which the central heating is shut off during the occupied period.
WARM WEATHER SHUT DOWN UNOCCUPIED	35 to 100°F (1.5 to 38.0°C) Default: 60°F (15.5°C)	Set the outdoor air temperature at which the central heating is shut off during the unoccupied period. This item is only available when Schedule > Device Schedule is On.
COLD WEATHER SHUT DOWN	Off or On Default: Off	Select if the control should shut down the central cooling based on the outdoor air temperature.
COLD WEATHER SHUT DOWN OCCUPIED	35 to 100°F (1.5 to 38.0°C) Default: 70°F (21.0°C)	Set the outdoor air temperature at which the central cooling is shut off during the occupied period.
COLD WEATHER SHUT DOWN UNOCCUPIED	35 to 100°F (1.5 to 38.0°C) Default: 60°F (15.5°C)	Set the outdoor air temperature at which the central cooling is shut off during the unoccupied period. This item is only available when Schedule > Device Schedule is On.

Settings (3 of 10)

Parameter	Range	Description
HEAT & COOL CALLS > HOT TANK LOOP		
HOT TANK TARGET	Outdoor Reset or Setpoint Default: Outdoor Reset	Select the logic in which the hot tank target is calculated. Outdoor Reset adjusts the water temperature based on the outdoor temperature and Setpoint sets a fixed temperature.
ROOM TEMPERATURE OCCUPIED	35 to 100°F (1.5 to 38.0°C) Default: 70°F (21.0°C)	Select the desired indoor air temperature during the Occupied time period. This parallel shifts the outdoor reset heating curve.
ROOM TEMPERATURE UNOCCUPIED	35 to 100°F (1.5 to 38.0°C) Default: 65°F (18.5°C)	Select the desired indoor air temperature during the Unoccupied time period. This parallel shifts the outdoor reset heating curve. Available when an Occupancy Schedule is Enabled.
HOT TANK DESIGN TEMPERATURE	50 to 230°F (10.0 to 110.0°C) Default: 110°F (43.5°C)	Select the hot tank temperature for the outdoor reset heating curve on the coldest day of the year. Determined by the heat loss calculation.
HOT TANK MINIMUM TEMPERATURE	50 to 230°F (10.0 to 110.0°C) Default: 50°F (10.0°C)	Set the minimum target temperature of the hot tank. This is important as the tank can be driven hotter due to differentials.
HOT TANK MAXIMUM TEMPERATURE	50 to 230°F (10.0 to 110.0°C) Default: 110°F (43.5°C)	Set the maximum target temperature of the hot tank.
HOT TANK SETPOINT TEMPERATURE	50 to 230°F (10.0 to 110.0°C) Default: 110°F (43.5°C)	Set the fixed temperature of the hot tank. Applies when Hot Tank Target is set to Setpoint.
HEAT & COOL CALLS > COLD TANK LOOP		
COLD TANK TARGET	Outdoor Reset or Setpoint Default: Outdoor Reset	Select the logic in which the cold tank temperature is calculated. Outdoor Reset adjusts the water temperature based on the outdoor temperature and Setpoint sets a fixed temperature.
ROOM TEMPERATURE OCCUPIED	35 to 100°F (1.5 to 38.0°C) Default: 78°F (25.5°C)	Select the desired indoor air temperature during the Occupied time period. This parallel shifts the outdoor reset cooling curve.
ROOM TEMPERATURE UNOCCUPIED	35 to 100°F (1.5 to 38.0°C) Default: 85°F (29.5°C)	Select the desired indoor air temperature during the Unoccupied time period. This parallel shifts the outdoor reset cooling curve. Available when an Occupancy Schedule is Enabled.
COLD TANK DESIGN TEMPERATURE	35 to 70°F (1.5 to 21.0°C) Default: 45°F (7.0°C)	Select the cold tank temperature for the outdoor reset cooling curve on the hottest day of the year. Determined by the heat gain calculation.
COLD TANK MINIMUM TEMPERATURE	35 to 70°F (1.5 to 21.0°C) Default: 45°F (7.0°C)	Set the minimum target temperature of the cold tank.
COLD TANK MAXIMUM TEMPERATURE	35 to 70°F (1.5 to 21.0°C) Default: 70°F (21.0°C)	Set the maximum target temperature of the cold tank.
COLD TANK SETPOINT TEMPERATURE	35 to 70°F (1.5 to 21.0°C) Default: 45°F (7.0°C)	Set the fixed temperature of the cold tank. Applies when Cold Tank Target is set to Setpoint.

Settings (4 of 10)

Parameter	Range	Description
HEAT & COOL CALLS > DOMESTIC HOT WATER		
DHW	Off or On Default: On	Select if the control responds to domestic hot water heating calls.
DHW TYPE	Heat Pump Loop, Hot Tank Loop, Side Arm Loop Default: Heat Pump Loop	Select the mode in which the DHW operates. Note: Boiler Side Arm is only allowed if Backup Type is Single Boiler
DHW SENSOR	Off or On Default: Off	Select if a sensor measures the DHW tank temperature for configurations where DHW Type is Heat Pump Loop or Hot Tank Loop. The DHW Sensor is mandatory in Boiler Side Arm configuration applications.
DHW TANK OCCUPIED	50 to 230°F (10.0 to 110.0°C) Default: 120°F (49.0°C)	Set the DHW tank temperature during the occupied period. Available when a DHW Sensor is set On.
DHW TANK UNOCCUPIED	50 to 230°F (10.0 to 110.0°C) Default: 120°F (49.0°C)	Set the DHW tank temperature during the Unoccupied period. Available when a DHW Sensor is set On and Occupancy Schedule is enabled.
DHW DIFFERENTIAL	1 to 42°F (0.5 to 23.5°C) Default: 6°F (3.5°C)	Set the DHW tank differential. The DHW call turns on when the temperature reaches the DHW Tank Occupied/Unoccupied setpoint minus the DHW Tank Differential. Available when DHW Sensor is set On.
DHW EXCHANGE OCCUPIED	50 to 230°F (10.0 to 110.0°C) Default: 120°F (49.0°C)	Set the heat pump loop temperature to heat the indirect DHW tank during the occupied period. Available when DHW Sensor is set Off.
DHW EXCHANGE UNOCCUPIED	Off or On Default: Off	Select if the DHW tank is heated during the unoccupied period. Available when DHW Sensor is set Off.
DHW PRIORITY	Off or On Default: Off	Select if the indirect DHW tank has priority over the central heating load.
DHW PRIORITY OVERRIDE	20 to 240 minutes Default: 240 minutes	Set the DHW priority override time after which central heating is resumed. Available when DHW Priority is On.
HEAT & COOL CALLS > MIX LOOP 1 THE MIX LOOP 1 IS AVAILABLE WHEN THE MIX 1 ENABLE IS ON.		
ROOM TEMPERATURE OCCUPIED	35 to 100°F (1.5 to 38.0°C) Default: 70°F (21.0°C)	Select the desired indoor air temperature during the Occupied time period. This parallel shifts the outdoor reset heating curve.
ROOM TEMPERATURE UNOCCUPIED	35 to 100°F (1.5 to 38.0°C) Default: 65°F (18.5°C)	Select the desired indoor air temperature during the Unoccupied time period. This parallel shifts the outdoor reset heating curve. Available when an Occupancy Schedule is Enabled.
MIX 1 DESIGN TEMPERATURE	50 to 230°F (10.0 to 110.0°C) Default: 110°F (43.5°C)	The supply water temperature required for the mix zones to heat the building on the typical coldest day of the year and determined by the heat loss calculation.
MIX 1 MINIMUM TEMPERATURE	50 to 230°F (10.0 to 110.0°C) Default: 50°F (10.0°C)	Set the minimum target temperature of the mix 1 loop.
MIX 1 MAXIMUM TEMPERATURE	50 to 230°F (10.0 to 110.0°C) Default: 110°F (43.5°C)	Set the maximum target temperature of the mix 1 loop.

Settings (5 of 10)

Parameter	Range	Description
HEAT & COOL CALLS > MIX LOOP 2 THE MIX LOOP 2 IS AVAILABLE WHEN THE MIX 2 ENABLE IS ON.		
ROOM TEMPERATURE OCCUPIED	35 to 100°F (1.5 to 38.0°C) Default: 70°F (21.0°C)	Select the desired indoor air temperature during the Occupied time period. This parallel shifts the outdoor reset heating curve.
ROOM TEMPERATURE UNOCCUPIED	35 to 100°F (1.5 to 38.0°C) Default: 65°F (18.5°C)	Select the desired indoor air temperature during the Unoccupied time period. This parallel shifts the outdoor reset heating curve. Available when an Occupancy Schedule is Enabled.
MIX 2 DESIGN TEMPERATURE	50 to 230°F (10.0 to 110.0°C) Default: 110°F (43.5°C)	The supply water temperature required for the mix zones to heat the building on the typical coldest day of the year and determined by the heat loss calculation.
MIX 2 MINIMUM TEMPERATURE	50 to 230°F (10.0 to 110.0°C) Default: 50°F (10.0°C)	Set the minimum target temperature of the mix 2 loop.
MIX 2 MAXIMUM TEMPERATURE	50 to 230°F (10.0 to 110.0°C) Default: 110°F (43.5°C)	Set the maximum target temperature of the mix 2 loop.
HEAT & COOL CALLS > MIX LOOP 3 THE MIX LOOP 3 IS AVAILABLE WHEN THE MIX 3 ENABLE IS ON.		
ROOM TEMPERATURE OCCUPIED	35 to 100°F (1.5 to 38.0°C) Default: 70°F (21.0°C)	Select the desired indoor air temperature during the Occupied time period. This parallel shifts the outdoor reset heating curve.
ROOM TEMPERATURE UNOCCUPIED	35 to 100°F (1.5 to 38.0°C) Default: 65°F (18.5°C)	Select the desired indoor air temperature during the Unoccupied time period. This parallel shifts the outdoor reset heating curve. Available when an Occupancy Schedule is Enabled.
MIX 3 DESIGN TEMPERATURE	50 to 230°F (10.0 to 110.0°C) Default: 110°F (43.5°C)	The supply water temperature required for the mix zones to heat the building on the typical coldest day of the year and determined by the heat loss calculation.
MIX 3 MINIMUM TEMPERATURE	50 to 230°F (10.0 to 110.0°C) Default: 50°F (10.0°C)	Set the minimum target temperature of the mix 3 loop.
MIX 3 MAXIMUM TEMPERATURE	50 to 230°F (10.0 to 110.0°C) Default: 110°F (43.5°C)	Set the maximum target temperature of the mix 3 loop.
SYSTEM SYSTEM > GENERAL		
SYSTEM TYPE	2-pipe or 4-pipe Default: 4-pipe	Select whether your system is a 2-pipe or 4-pipe configuration.
BACKUP TYPE	None, Single Boiler, Boiler Loop Default: None	Select configuration for a backup boiler for the system. Select Boiler Loop if you are connecting a tekmar Smart Boiler Control 294 to operate an independent boiler loop.
MIX 1 ENABLE	Off or On Default: Off	Select if Mix 1 is connected to a tekmar Smart Mix Expansion 295
MIX 2 ENABLE	Off or On Default: Off	Select if Mix 2 is connected to a tekmar Smart Mix Expansion 295. Only available if Mix 1 is enabled.
MIX 3 ENABLE	Off or On Default: Off	Select if Mix 3 is connected to a tekmar Smart Mix Expansion 295. Only available if Mix 1 & 2 are enabled and Backup Type is None or Single Boiler. Note: Mix 3 is forced to Off when Backup Type is set to Boiler Loop.
OUTDOOR SENSOR	Control, tekmarNet, Internet Default: Control	Set the source of the outdoor air sensor reading. tekmarNet is available when connected to a tekmarNet communication system. Internet is available when connected to the Internet through Ethernet or Wi-Fi.
EXERCISING	Off or On Default: Off	Select if the control should exercise the pumps and valves every 72 hours to prevent pump or valve seizure.

Settings (6 of 10)

Parameter	Range	Description
TN4 BUS 2	Off, Tank, Mix 1 Default: Off	Select the tekmarNet Bus 2 configuration. Select Off if the bus is not used. Select Tank to extend the number of devices on the tank bus. Select Mix 1 if a 295 is installed.
TN4 BUS 3	Off, Tank, Mix 1, Mix 2 Default: Off	Select the tekmarNet Bus 3 configuration. Select Off if the bus is not used. Select Tank or Mix 1 to extend the number of devices on the tank or mix 1 buses respectively. Select Mix 2 if two 295 are installed.
TN4 BUS 4	Off, Tank, Mix 1, Mix 2, Mix 3 Default: Off	Select the tekmarNet Bus 4 configuration. Select Off if the bus is not used. Select Tank, Mix 1 or Mix 2 to extend the number of devices on the tank, mix 1, or mix 2 buses respectively. Select Mix 3 if three 295 are installed. Boiler is automatically selected when a 294 is installed.
SYSTEM > HEAT PUMP STAGING		
HEAT PUMP GROUP ROTATION	Off or On Default: On	Select if the heat pumps should rotate their staging order to balance the running hours.
HEAT PUMP DIFFERENTIAL	2 to 20°F (1.0 to 11.0°C) Default: 4°F (2.0°C)	Select the heat pump on-off differential. The first stage heat pump turns on ½ differential below the target and shuts off at ½ differential above the target.
HEAT PUMP AUTO STAGE DELAY	Off or On Default: On	Select if automatic staging is used.
HEAT PUMP MANUAL STAGE DELAY	0.5 to 40.0 minutes Default: 6.0 minutes	Select manual staging delay between heat pump stages. Available when Auto Stage Delay is Off.
HEAT PUMP PRIORITY	Heat or Cool Default: Heat	Select if heating or cooling is the priority in 2-pipe configurations and both hot tank and cold tank calls are present.
HEAT PUMP MINIMUM RUN TIME	0.5 to 30.0 minutes Default: 2.0 minutes	Set the minimum run time required when a heat pump is turned on.
HEAT PUMP MINIMUM TIME OFF	0.5 to 30.0 minutes Default: 5.0 minutes	Set the minimum off time the heat pump must remain off after shutting off.
HEAT PUMP RETURN MINIMUM	40 to 70°F (4.5 to 21.0°C) Default: 40°F (4.5°C)	Select the minimum temperature on the cold tank return pipe at which the heat pumps are shut off.
HEAT PUMP RETURN MAXIMUM	70 to 180°F (21.0 to 82.0°C) Default: 110°F (43.5°C)	Select the maximum temperature on the hot tank return pipe at which the heat pumps are shut off.
HEAT-COOL INTERLOCK	5 to 180 minutes Default: 5 minutes	The heat-cool interlock prevents excessive heat-cool switchovers in 2-pipe systems.
BALANCE POINT ENABLE	Off or On Default: Off	Select if the air source heat pumps should shut off during cold outdoor weather. Available when the Backup Type is set to Single Boiler or Boiler Loop and Heat Pump Source is set to Air Source on all Heat Pumps.
BALANCE POINT	-22 to 70°F (-30.0 to 21.0°C) Default: 32°F (0.0°C)	Select the outdoor air temperature at which the heat pumps are shut off. Available when Balance Point Enable is On.
SYSTEM > BACKUP		
BACKUP DELAY	10 to 180 minutes Default: 60 minutes	After all available heat pumps are on, select the amount of time delay before the backup boiler is turned on to provide heat to the hot tank loop.
TRANSFER PUMP TYPE	On-Off, 0-10V Modulating, 4-10mA Modulating Default: On-Off	Select the type of signal used to operate the transfer pump. Only Available when Backup Type is set to Boiler Loop.
TRANSFER PUMP DIFFERENTIAL	2 to 20°F (1.0 to 11.0°C) Default: 4°F (2.0°C)	Select the transfer pump differential when operating an on-off transfer pump.

Settings (7 of 10)

Parameter	Range	Description
SYSTEM > DIVERTING VALVES		
DIVERTING VALVE PAIRS	Per Heat Pump, Per Group Default: Per Heat Pump	Select if a set diverting valves pairs are available for each heat pump or a single set of diverting valve pairs are for all the heat pumps.
DIVERTING VALVE MOTOR SPEED	10 to 230 seconds Default: 30 seconds	Select the amount of time the diverting valve takes to open or close.
SYSTEM > MIXING		
MIX 1 TYPE	Variable Speed Injection, Floating Action Valve, 0-10 Vdc, 4-20mA Default: Floating Action Valve	Select the type of mixing for the mix 1 loop. Available when Mix 1 Loop is On
MIX 1 MOTOR SPEED	30 to 230 seconds Default: 140 seconds	Select the amount of time for the mixing valve to change from closed to open position. Available when Mix 1 Loop is On and Mix 1 Type is not Variable Speed Injection
MIX 2 TYPE	Variable Speed Injection, Floating Action Valve, 0-10 Vdc, 4-20mA Default: Floating Action Valve	Select the type of mixing for the mix 2 loop. Available when Mix 2 Loop is On
MIX 2 MOTOR SPEED	30 to 230 seconds Default: 140 seconds	Select the amount of time for the mixing valve to change from closed to open position. Available when Mix 2 Loop is On and Mix 2 Type is not Variable Speed Injection
MIX 3 TYPE	Variable Speed Injection, Floating Action Valve, 0-10 Vdc, 4-20mA Default: Floating Action Valve	Select the type of mixing for the mix 3 loop. Available when Mix 3 Loop is On
MIX 3 MOTOR SPEED	30 to 230 seconds Default: 140 seconds	Select the amount of time for the mixing valve to change from closed to open position. Available when Mix 3 Loop is On and Mix 3 Type is not Variable Speed Injection
HEAT PUMPS		
ALL SETTINGS ARE AVAILABLE UNDER HEAT PUMPS 1 TO 4 AND UNDER HEAT PUMPS 5-16 WHEN UP TO 3 TEKMAR SMART HEAT PUMP EXPANSION 291EXP ARE CONNECTED TO THE SYSTEM.		
HEAT PUMP AVAILABLE	Off or On Default: Heat Pump 1 - On Heat Pumps 2-16 - Off	Select if the Heat Pump is available as part of the operating sequence. The Heat Pump should be set to Off if not in use or the Heat Pump is off line for maintenance. Heat Pump 1 is available when backup type is None or Boiler Loop. Heat Pumps 2-4 are always available. Heat Pumps 5 to 16 are visible when up to 3 tekmar Smart Heat Pump Expansion 291EXP are detected.
HEAT PUMP MANUFACTURER	Based on preset files Default: Custom	Select the heat pump manufacturer. Choose Custom if the installed heat pump is not included in the list.
HEAT PUMP SERIES	Based on preset files	Depends on the heat pump manufacturer selection. Select the heat pump series. Available when a heat pump manufacturer name is selected.
HEAT PUMP MODEL	Based on preset files	Select the heat pump model. Available when a heat pump manufacturer name is selected. Depends on heat pump series selection.
HEAT PUMP SOURCE	Air Source or Geo Exchange Default: Air Source	Select between air source or geo exchange heat pumps.
HEAT PUMP RELAY	Y+O, Y+B, Heat-Cool Default: Y+O	Select the relay logic of the heat pump. Select Y+O for normally heating heat pumps. Select Y+B for normally cooling heat pumps. Select Heat-Cool for some types of air source heat pumps. Consult heat pump manufactures manual for wiring instructions.

Settings (8 of 10)

Parameter	Range	Description
HEAT PUMP FUEL	Electric, NG Gas, LP Gas Default: Electric	Select the fuel source of the heat pump.
HEAT PUMP TYPE	1-Stage, 2-Stage Default: 1-Stage	Select the number of stages of the heat pump. The 2-stage option is only available on the first 3 stages of the control and each of the Expansion Modules.
ELECTRICAL INPUT	1 to 100,000 W Default: 6,000 W	Select the electrical consumption of the heat pump.
GAS INPUT	10 to 9,990 MBTU/hr Default: 95 MBTU/hr	Select the gas consumption of the heat pump.
BOILER		
BOILER AVAILABLE	Off or On Default: Off	Select if the boiler is available as part of the firing sequence. The boiler should be set Off if not in use or the boiler is off line for maintenance.
BOILER MANUFACTURER	Based on presets file Default: Custom	Select the boiler manufacturer. Choose Custom if the installed boiler is not included in the list.
BOILER SERIES	Based on presets file	Select the boiler series. Available when a boiler manufacturer name is selected. Available when manufacturer is selected. Depends on boiler series selection.
BOILER MODEL	Based on presets file	Select the boiler model. Available when a boiler manufacturer name is selected. Depends on boiler series selection.
BOILER FUEL	NG Gas, LP Gas, Oil, Electric, Wood Default: NG Gas	Select the fuel source of the boiler.
BOILER TYPE	1-Stage, Modulating Fire Rate, Modulating Target Temperature, Electric Default: 1-stage	Select if the boiler is 1-stage or modulating. Both modulating firing rate and target temperature are supported.
BOILER GROUP	Condensing or Non-Condensing Default: Non-condensing	Select between a condensing or non-condensing boiler.
BOILER MASS	Low, Medium, High, Very High Default: Medium	Set the boiler's mass. This setting changes the PID staging operation. Setting a higher mass makes the time delay between boiler stages longer.
FIRE DELAY	10 to 180 seconds Default: 30 seconds	Set the fire delay time. This is the time duration from when the control provides an enable signal to when the boiler completes ignition.
BOILER HIGH OUTPUT	10 to 9,990 MBTU/h Default: 400 MBTU/h	Set the boiler burner's BTU output at full fire. Units are in thousands of BTUs per hour.
MODULATION TYPE	0-10Vdc, 4-20 mA Default: 0-10 Vdc	Set the type of analog signal received by the boiler to modulate the firing rate or target temperature. Available when boiler type is set to modulating.
BOILER LOW OUTPUT	10 to 9,990 MBTU/h Default: 80 MBTU/h	Set the boiler burner's BTU output at low fire. Units are in thousands of BTUs per hour. Available when boiler type is set to modulating fire rate.
MODULATION DELAY	0 to 180 seconds Default: 0 seconds	Set the modulation delay time. This is the time that the boiler burner modulation is held at low fire. Available when boiler type is set to modulating fire rate.
MODULATION MOTOR SPEED	10 to 230 seconds Default: 30 seconds	Set the modulation motor speed. This is the time required to change from low to high fire. Available when boiler type is set to modulating fire rate.
START MODULATION	0 to 50% Default: 0%	Set the starting modulation rate during boiler ignition. Available when boiler type is set to modulating fire rate.
MINIMUM MODULATION	0 to 50% Default: 0%	Set the low fire modulation rate. Available when boiler type is set to modulating fire rate.
MAXIMUM MODULATION	50 to 100% Default: 100%	Set the high fire modulation rate. Available when boiler type is set to modulating fire rate.

Settings (9 of 10)

Parameter	Range	Description
OUTPUT EMS SIGNAL MINIMUM	0.5 to 10.0 Vdc Default: 1.0 Vdc	Set the EMS output signal minimum DC voltage to the boiler. Available when boiler type is set to modulating target temp.
EMS TEMPERATURE MINIMUM	50 to 210°F (10.0 to 99.0°C) Default: 50°F (10.0°C)	The EMS signal operates on a linear scale. Set the temperature when the EMS signal is at the lowest output. Available when boiler type is set to modulating target temp.
EMS TEMPERATURE MAXIMUM	50 to 210°F (10.0 to 99.0°C) Default: 210°F (99.0°C)	The EMS signal operates on a linear scale. Set the temperature when the EMS signal is at the highest output of 10 Vdc or 20 mA. Available when boiler type is set to modulating target temp.
POST PURGE	0.0 to 20.0 minutes Default: 2.0 minutes	Set the boiler pump post purge time after the burner has shut off.
ALERTS		
HOT TANK HIGH TEMPERATURE ALERT	32 to 230°F (0.0 to 110.0°C) Default: 230°F (110.0°C)	Set the threshold above which the control triggers a high temperature alert notification. Available in 4-pipe configuration.
HOT TANK LOW TEMPERATURE ALERT	32 to 230°F (0.0 to 110.0°C) Default: 32°F (0.0°C)	Set the threshold below which the control triggers a low temperature alert notification. Available in 4-pipe configuration.
COLD TANK HIGH TEMPERATURE ALERT	32 to 230°F (0.0 to 110.0°C) Default: 122°F (50.0°C)	Set the threshold above which the control triggers a high temperature alert notification. Available in 4-pipe configuration.
COLD TANK LOW TEMPERATURE ALERT	32 to 230°F (0.0 to 110.0°C) Default: 32°F (0.0°C)	Set the threshold below which the control triggers a low temperature alert notification. Available in 4-pipe configuration.
TANK HIGH TEMPERATURE ALERT	32 to 230°F (0.0 to 110.0°C) Default: 230°F (110.0°C)	Set the threshold above which the control triggers a high temperature alert notification. Available in 2-pipe configuration.
TANK LOW TEMPERATURE ALERT	32 to 230°F (0.0 to 110.0°C) Default: 32°F (0.0°C)	Set the threshold below which the control triggers a low temperature alert notification. Available in 2-pipe configuration.
MIX 1 HIGH TEMPERATURE ALERT	32 to 230°F (0.0 to 110.0°C) Default: 230°F (110.0°C)	Set the threshold above which the control triggers a high temperature alert notification. Available when Mix 1 is enabled.
MIX 1 LOW TEMPERATURE ALERT	32 to 230°F (0.0 to 110.0°C) Default: 32°F (0.0°C)	Set the threshold below which the control triggers a low temperature alert notification. Available when Mix 1 is enabled.
MIX 2 HIGH TEMPERATURE ALERT	32 to 230°F (0.0 to 110.0°C) Default: 230°F (110.0°C)	Set the threshold above which the control triggers a high temperature alert notification. Available when Mix 2 is enabled.
MIX 2 LOW TEMPERATURE ALERT	32 to 230°F (0.0 to 110.0°C) Default: 32°F (0.0°C)	Set the threshold below which the control triggers a low temperature alert notification. Available when Mix 2 is enabled.
MIX 3 HIGH TEMPERATURE ALERT	32 to 230°F (0.0 to 110.0°C) Default: 230°F (110.0°C)	Set the threshold above which the control triggers a high temperature alert notification. Available when Mix 3 is enabled.
MIX 3 LOW TEMPERATURE ALERT	32 to 230°F (0.0 to 110.0°C) Default: 32°F (0.0°C)	Set the threshold below which the control triggers a low temperature alert notification. Available when Mix 3 is enabled.
HOT TANK NO HEAT ALERT ENABLE	Off or On Default: Off	Select if an alert is triggered if there is no temperature rise when the heat pumps are operating. Available when in 4-pipe configuration.
HOT TANK NO HEAT ALERT	0.5 to 80.0 minutes Default: 60.0 minutes	Set the amount of time that all heat pumps are running at 100% and the hot tank temperature is not reaching the hot tank target, before triggering an alert notification. Available when in 4-pipe configuration.
COLD TANK NO COOL ALERT ENABLE	Off or On Default: Off	Select if an alert is triggered if there is no temperature decrease when the heat pumps are operating. Available when in 4-pipe configuration.

Settings (10 of 10)

Parameter	Range	Description
COLD TANK NO COOL ALERT	0.5 to 80.0 minutes Default: 60.0 minutes	Set the amount of time that all heat pumps are running at 100% and the cold tank temperature is not reaching the cold tank target, before triggering an alert notification. Available when in 4-pipe configuration.
TANK NO HEAT ALERT ENABLE	Off or On Default: Off	Select if an alert is triggered if there is no temperature rise when the heat pumps are operating. Available when in 2-pipe configuration.
TANK NO HEAT ALERT	0.5 to 80.0 minutes Default: 60.0 minutes	Set the amount of time that all heat pumps are running at 100% and the tank temperature is not reaching the tank target, before triggering an alert notification. Available when in 2-pipe configuration.
TANK NO COOL ALERT ENABLE	Off or On Default: Off	Select if an alert is triggered if there is no temperature decrease when the heat pumps are operating. Available when in 2-pipe configuration.
TANK NO COOL ALERT	0.5 to 80.0 minutes Default: 60.0 minutes	Set the amount of time that all heat pumps are running at 100% and the tank temperature is not reaching the tank target, before triggering an alert notification. Available when in 2-pipe configuration.
BOILER SERVICE HOURS ALERT	1,000 to 25,000 hours Default: 5,000 hours	Set the number of boiler running hours above which the control triggers a boiler service alert notification. Available when Backup Type is set to Single Boiler and Boiler Available is On.
BOILER SERVICE CYCLE ALERT	1 to 25,000 cycles Default: 25,000 cycles	Set the number of boiler on/off cycles above which the control triggers a boiler service alert notification. Available when Backup Type is set to Single Boiler and Boiler Available is On.
FOR HEAT PUMPS 1 TO 16		
HEAT PUMP (N) SERVICE HOURS ALERT	1,000 to 25,000 hours Default: 5,000 hours	Set the number of heat pump running hours above which the control triggers a heat pump service alert notification.
HEAT PUMP (N) SERVICE CYCLES ALERT	1 to 25,000 cycles Default: 25,000 cycles	Set the number of heat pump on/off cycles above which the control triggers a heat pump service alert notification.
SECURITY		
REQUIRE PASSCODE	Off or On Default: Off	Select if a passcode is required to enter the Home screen.
PASSCODE		Select to change the personal passcode.

Schedule Menu

The control can follow two types of schedules to provide additional energy savings.

- Occupancy Schedule
- Dual Fuel Schedule

The control can only have one active schedule type.

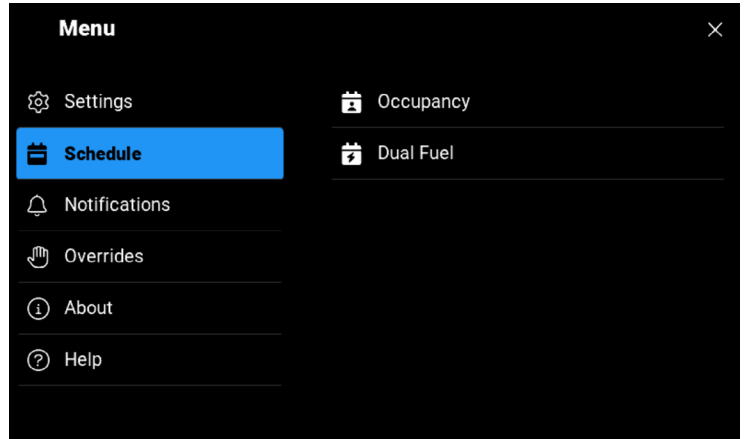

When creating a new schedule, choose the days that share the same scheduled times.

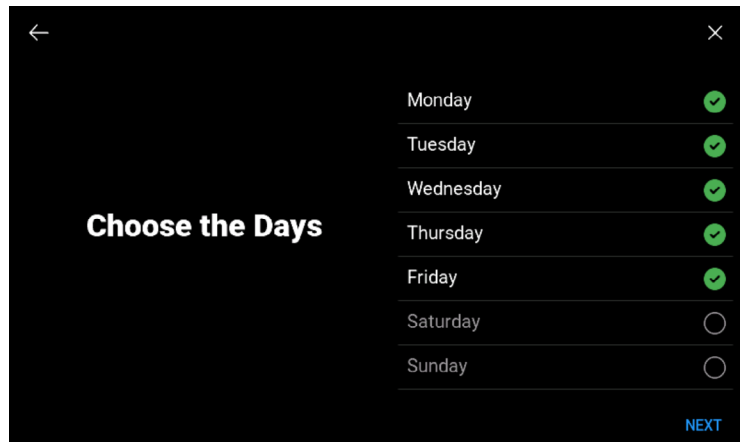

Parameter	Range	Description
OCCUPANCY SCHEDULE		
OCCUPANCY SCHEDULE	Off or On Default: Off	Select to turn on the occupancy schedule.
DAYS	Monday through Sunday	Select the days to create a schedule. You will repeat the process until all days are selected.
OCCUPIED 1 TIME	12:00 am to 11:50 pm (0:00 to 23:50) Default: 6:00 am (6:00)	Set the occupied 1 time. Select "SKIP" to ignore the occupied 1-time event.
UNOCCUPIED 1 TIME	12:00 am to 11:50 pm (0:00 to 23:50) Default: 8:00 am (8:00)	Set the unoccupied 1 time. Select "SKIP" to ignore the unoccupied 1-time event.
OCCUPIED 2 TIME	12:00 am to 11:50 pm (0:00 to 23:50) Default: 6:00 pm (18:00)	Set the occupied 2 time. Select "SKIP" to ignore the occupied 2-time event.
UNOCCUPIED 2 TIME	12:00 am to 11:50 pm (0:00 to 23:50) Default: 10:00 am (22:00)	Set the unoccupied 2 time. Select "SKIP" to ignore the unoccupied 2-time event.
DUAL FUEL SCHEDULE		
DUAL FUEL SCHEDULE	Off or On Default: Off	Select to turn on the dual fuel schedule.
DAYS	Monday through Sunday	Select the days to create a schedule. You will repeat the process until all days are selected.
ON-PEAK ELECTRICITY TIME 1	12:00 am to 11:50 pm (0:00 to 23:50) Default: 7:00 am (7:00)	Set the on-peak electricity 1 time. Select "SKIP" to ignore the On-Peak 1-time event.
OFF-PEAK ELECTRICITY TIME 1	12:00 am to 11:50 pm (0:00 to 23:50) Default: 8:00 pm (20:00)	Set the off-peak electricity 1 time. Select "SKIP" to ignore the Off-Peak 1-time event.
ON-PEAK ELECTRICITY TIME 2	12:00 am to 11:50 pm (0:00 to 23:50) Default: 8:00 pm (20:00)	Set the on-peak electricity 2 time. Select "SKIP" to ignore the On-Peak 2-time event.
OFF-PEAK ELECTRICITY TIME 2	12:00 am to 11:50 pm (0:00 to 23:50) Default: 8:00 pm (20:00)	Set the off-peak electricity 2 time. Select "SKIP" to ignore the Off-Peak 2-time event.

Notifications Menu

The control keeps track of the last 30 errors and alert notifications. Refer to the Troubleshooting section for corrective action.

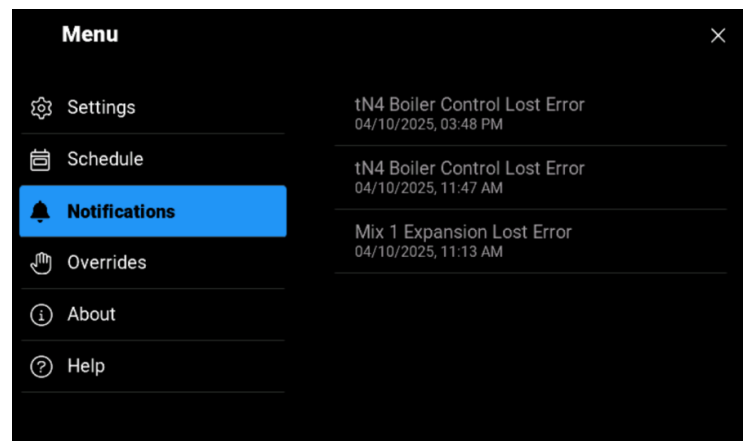

Overrides Menu

Commissioning, testing and troubleshooting features of the 291 are accessed through the Override menu.

The Manual Override has six different modes including:

Automatic

The normal operating mode for the control is automatic.

Purge Override

In this mode, the control overrides the normal operating mode and operates pumps. This mode is useful for purging air out of the system.

- Hot Tank and Cold Tank pumps are turned on.
- DHW pump: operation of the DHW pump is dependent on the settings in the Domestic Hot Water Call menu.
- Mix System pump(s): operation of the Mix system pump is dependent on the settings in the Mixing Call menu.
- Purge will operate for a fixed period of 72 hours. After the purge period expires, the control will revert to Automatic operation. The purge override can also be terminated by selecting automatic.

Max Heat Override

In this mode, the control overrides the normal operating mode and operates the system to maintain the hot tank maximum target.

This function is useful on start-up, commissioning, and when drying sheet rock and paint in the building.

- Operation of the equipment is dependent on the system.
- WWSD, DHW and Setpoint Priority are disabled during Max Heat.
- Max Heat will operate for 24 hours. After the timeout period elapses, the control will revert to Automatic mode.

The max heat override can also be terminated by selecting automatic.

Max Cool Override

In this mode, the control overrides the normal operating mode and operates the system to maintain the cold tank minimum target.

This function is useful on start-up and commissioning.

- Operation of the equipment is dependent on the system.
- CWSD and Setpoint Priority are disabled during Max Cool.
- Max Cool will operate for 24 hours. After the timeout period elapses, the control will revert to Automatic mode. The max cool override can also be terminated by selecting automatic.

Hand Override

In this mode, the control overrides the normal operating mode allows for manual operation of the equipment. This mode is useful for testing and assisting with troubleshooting.

- Operation of the equipment is dependent on the settings in the Settings menu.
- Hand mode will operate for 1 hour. After the timeout period elapses, the control will revert to Automatic mode. The hand override can also be terminated by selecting automatic.

Off Override

In this mode, the control overrides the normal operating mode and forces the entire system into standby. This mode is useful for conducting maintenance or change out of mechanical components in the system.

- The Off override can be terminated at any time by selecting automatic.

Overrides Menu

Parameter	Range	Description
OPERATION	Automatic, Hand, Purge, Max Heat, Max Cool, Off	Set the manual override. Automatic reverts to normal operation. Hand allows each output to be turned on or set manually. Purge turns on the pumps to remove air from the system. No heat pumps are enabled. Max Heat/Cool operates the system with all heat pumps enabled. Off places the control into a standby state and the heat pumps and pumps are not operated.
HOT TANK SYSTEM PUMP	Off or On Default: Off	Select to turn on the hot tank pump. Available in Hand override.
COLD TANK SYSTEM PUMP	Off or On Default: Off	Select to turn on the cold tank pump. Available in Hand override.
DHW PUMP	Off or On Default: Off	Select to turn on the DHW pump. Available in Hand override.
TRANSFER PUMP	Off or On Default: Off	Select to turn on the transfer pump. Available in Hand override when backup type is boiler loop.
DIVERTING VALVE (N)	Heat or Cool Default: Heat	Select the position of the diverting valve. Available in Hand override.
HEAT PUMP (N)	Off, Heat, Cool Default: Off	Select to turn on the heat pump in heat or cool operation. Available in Hand override.
MIX (N) CHILLED WATER RELAY	Off or On Default: Off	Select if the Mix (n) chilled water relay is open. Available in Hand override when a diverting valve is connected to the mixing expansion.
MIX (N) SYSTEM PUMP	Off or On Default: Off	Select to turn on the Mix (n) System pump. Available in Hand override.
MIX (N) OUTPUT	Off or On Default: Off	Select the Mix percentage of Mix (n). Available in Hand override.

About Menu

The About menu lists all details about the control. This information may be required when contacting tekmar for support.

Menu			
Settings	Model Name	Smart Heat Pump	
Schedule	Model Number	291	
Notifications	Software	0.4.0-42-g41df	
Overrides	Hardware	1	
About	Mix Expansion 1	1.0.0	
Help	Mix Expansion 2	1.0.0	
	ID	N/A	

Help Menu

Scan the QR code with your mobile phone to be directed to the product website to find specifications, manuals, and videos.

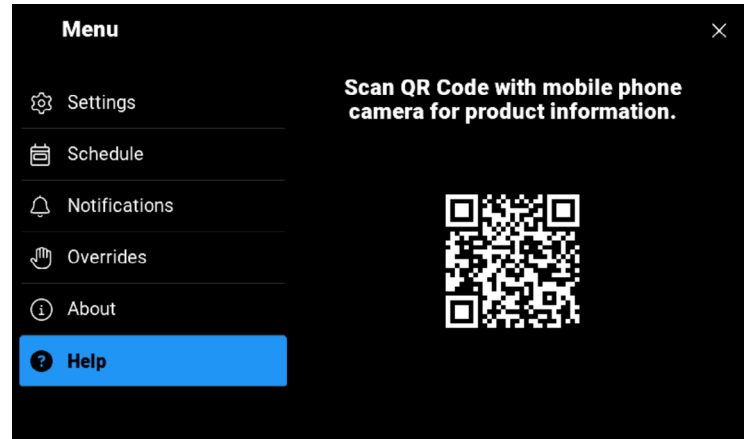

Registering to Nexa

Go to the Settings > Internet menu

Connect the control to the Internet.

Select Nexa.

The control will display an 8-digit registration code. The code is valid for 30 minutes.

Scan the QR Code.

Or go to <https://app.nexaplatform.com/welcome> and follow the instructions on the screen to register your device to Nexa.

Nexa is designed to replicate all usability as on the control. For more specific tutorials, go to the help section on the web/mobile app to access more information.

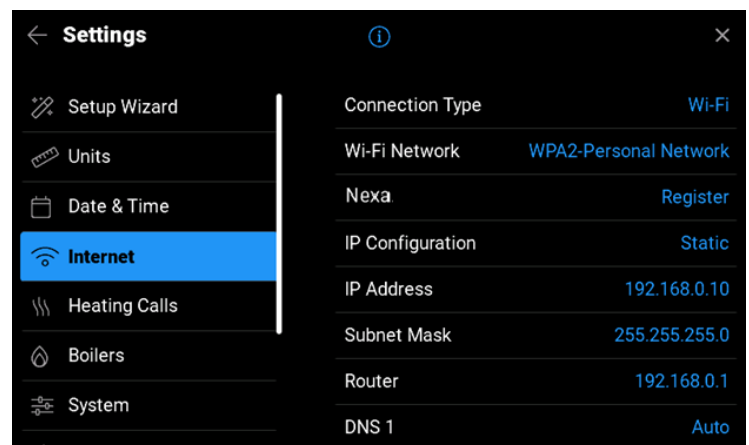

Sequence of Operation

System Overview

The Smart Heat Pump Control 291 is a central hydronic controller that operates up to 4 heat pumps. This can be expanded with the tekmar Smart Heat Pump Expansion 291EXP, the tekmar Smart Mix Expansion 295 and connection to the tekmar Smart Boiler Control 294.

The Heat Pump Expansion 291EXP adds support for an additional 4 heat pumps at a time. A total of three 291EXP can be added to the 291 for a total capacity of 16 heat pumps.

The Smart Mix Expansion 295 adds one mix water temperature. Mix water loops are used when separating higher temperature fan coils, staple-up and in floor radiant floor heating/cooling

loops from each other. A total of three 295 can be added to support up to 3 mix water temperatures. This is limited to two 295 when a Smart Boiler Control 294 is installed in the system.

The Smart Boiler Control 294 adds up to 4 backup boilers when connected to the 291. This can be expanded in groups of 4 boilers at a time using the Boiler Expansion 294EXP for a maximum of 16 boilers. The backup boilers can be used to supplement heat pump heating or provide full backup when the heat pumps are shutoff for economic reasons such as balance point or electrical utility rate programs.

The following table shows the available expansion combinations.

Equipment	Heat Pumps	Boilers	Boiler Loop	Mix Loops
No Backup Boiler				
291	4	0	0	0
291, 291EXP	8	0	0	0
291, 2x291EXP	12	0	0	0
291, 3x291EXP	16	0	0	0
Single Backup Boiler in line with Heat Pumps				
291	3	1	0	0
291, 291EXP	7	1	0	0
291, 2x291EXP	11	1	0	0
291, 3x291EXP	15	1	0	0
When using Multiple Backup Boilers				
291, 294	4	4	1	0
291, 291EXP, 294	8	4	1	0
291, 2x291EXP, 294	12	4	1	0
291, 3x291EXP, 294	16	4	1	0
With Maximum Boiler Expansions				
291, 294, 3x294EXP	4	16	1	0
291, 291EXP, 294	8	16	1	0
291, 2x291EXP, 294	12	16	1	0
3x291EXP, 294	16	16	1	0
Mixing Expansions				
291, 295	4	0	0	1
291, 2x295	4	0	0	2
291, 3x295	4	0	0	3
Largest Supported Systems				
291, 3x291EXP, 3x295	16	0	0	3
291, 3x291EXP, 294, 3x294EXP, 2x295	16	16	1	2

System Type

The 291 supports either 2-pipe or 4-pipe systems.

2-Pipe Systems

A 2-pipe system may include one buffer tank, and the same pipes are used to deliver hot water or chilled water to the hydronic zones. A switchover process is required to change between heating and cooling. The switchover process may be set manually by the user or automatically when the majority of thermostats vote for change from heating to cooling or vice versa.

A 2-pipe system may not include a buffer tank; however, this may cause unwanted heat pump cycling during low load conditions. The cycling rate is determined by the minimum output of one heat pump compared the minimum load of the smallest zone. If the load is smaller than the minimum heat pump output, cycling will occur.

Calls

The 291 supports both local on/off and tekmarNet calls for heating and cooling. Once a call is received, it usually causes a tank target, boiler target or mix target to be calculated. Exceptions include while the control is in Warm Weather Shut Down or Cold Weather Shut Down.

Local Heat and Cool Calls

A local heating or cooling call can be either a contact closure or a 24 V(ac) signal from a thermostat. Local calls include the hot tank call, cold tank call, domestic hot water (DHW) tank call, boiler calls (available on the Smart Boiler Control 294) and mix calls (available on Smart Mix Expansion 295). Local calls can use either outdoor reset or a fixed setpoint to determine the target for each loop. Local heat and cool calls always have priority over tekmarNet calls.

Heating Outdoor Reset

Outdoor reset progressively increases the loop water target with colder outdoor air temperatures. This is often referred to as the heating curve. This allows the heat source to match the heat loss of the building. This results in lower operating temperatures and increases the heat pump's Coefficient of Performance (COP) for higher efficiency. The hot tank, boiler, and mixing loops each have their own heating curves.

The heating curve is defined by:

- Indoor Design Temperature (fixed to 70°F or 21°C)
- Outdoor Start Temperature (fixed to 70°F or 21°C)
- Loop Design Temperature (determined by a heat loss calculation)
- Outdoor Design Temperature (the coldest outdoor air temperature expected in your local region and used in heat loss calculations)

The target temperature is limited by the loop minimum and maximum temperatures. The control includes a Room Temperature setting that allows the calculated target to parallel shift up or down along the heating curve.

Heat Setpoint

The heating setpoint is a fixed temperature. This results in lower efficiency compared to outdoor reset.

4-Pipe Systems

A 4-pipe system includes two buffer tanks: one for hot and another for chilled water. This allows the system to provide both heating and cooling at the same time. A 4-pipe system requires 6-way diverting valves (or pairs of 3-way diverting valves) on the heat pump supply and return pipes to direct hot or chilled water to the appropriate tank. Directing valves are required on both the supply and return pipes to provide isolation of flow between the tanks and prevent unwanted heat transfer between the hot and cold tanks. Each buffer tank requires its own makeup feed glycol line and expansion tank.

Warm Weather Shut Down

Hot tank, boiler and mix heating calls are disabled when the outdoor air temperature exceeds the Warm Weather Shut Down setting by 1°F or 0.5°C. Heating calls resume when the outdoor air temperature falls below the Warm Weather Shut Down setting by 1°F or 0.5°C.

Cooling Outdoor Reset

Outdoor reset progressively decreases the cold tank target with warmer outdoor air temperatures. This is referred to as the cooling curve. This results in higher operating temperatures and increases the heat pump's Coefficient of Performance (COP) for higher efficiency.

The cooling curve is defined by:

- Indoor Design Temperature (fixed to 70°F or 21°C)
- Outdoor Start Temperature (fixed to 70°F or 21°C)
- Loop Design Temperature (determined by a heat loss calculation)
- Outdoor Design Temperature (the coldest outdoor air temperature expected in your local region and used in heat loss calculations)
- The target temperature is limited by the loop minimum and maximum temperatures. The control includes a Room Temperature setting that allows the calculated target to parallel shift up or down along the cooling curve.

Cooling Setpoint

The cooling setpoint is a fixed temperature. Many chilled water systems are designed to operate with a supply water temperature of 45°F (7.5°C).

Cold Weather Shut Down

Cold tank and mix cooling calls are disabled when the outdoor air temperature falls below the Cold Weather Shut Down setting by 1°F or 0.5°C. Cooling calls resume when the outdoor air temperature exceeds the Cold Weather Shut Down setting by 1°F or 0.5°C.

tekmarNet Calls

In a tekmarNet system, each thermostat calculates a desired water temperature based upon factors such as the temperature difference between the heating setpoint and the measured room temperature, along with other factors such as the heating cycle length. The result is that the tekmarNet system automatically determines the highest heat loss zone and this determines the hot tank loop, boiler loop or mix loop temperature. The highest heat loss zone operates 100% of each heating cycle. Lower heat loss zones reduce their percent on time to prevent the zone from overheating. The tekmarNet call for heat target is limited by the heating curve minimum and maximum temperatures.

Cold tank calls work in a similar manner where each cooling thermostat calculates a desired water temperature based upon the temperature difference between the cooling setpoint and the measured room temperature, along with other factors such as the cooling cycle length. When operating a fancoil, the cold tank and mix target is limited by the cooling curve minimum and maximum temperature and is not restricted by the dewpoint temperature.

Radiant Cooling and Dewpoint Reset

Select tekmarNet thermostat models support radiant floor cooling. The thermostat's measure the room temperature and the room relative humidity and calculate a dewpoint temperature. The cold tank target or the mix loop target is operated 2°F or 1°C above the highest dewpoint temperature. This prevents condensation on pipes and radiant manifolds.

tekmarNet Communication Buses

The 291 includes four optional tekmarNet (tN4) communication buses. Each tekmarNet bus regulates one hydronic loop temperature and supports up to 24 thermostats, snow melt or setpoint controls.

The 291 always supports the Tank loop on Bus 1. Bus 2, 3 and 4 can be assigned to Tank, Mix 1, Mix 2, Mix 3 and Boiler loops depending on the connected 291EXP and 295 expansion devices.

Control Combinations	tN4 Bus 1	tN4 Bus 2	tN4 Bus 3	tN4 Bus 4
291	Tank	Off or Tank	Off or Tank	Off or Tank
291 and 294	Tank	Off, Tank or Boiler	Off, Tank or Boiler	Boiler
291, 294, 1 of 295	Tank	Mix 1	Off, Tank, Mix 1 or Boiler	Boiler
291, 294, 2 of 295	Tank	Mix 1	Mix 2	Boiler
291, 3 of 295	Tank	Mix 1	Mix 2	Mix 3

In cases where a tN4 bus is not required for a hydronic loop, two or more tekmarNet buses can be assigned to the same hydronic loop temperature. This allows the configuration of system that have more than 24 thermostats on a hydronic loop temperature.

2-Pipe Operation

2-Pipe Switchover

In a 2-pipe system, the same buffer tank is used for both heating or cooling and includes a Mode setting that supports the following:

Mode	Operation
Off	System does not provide space heating or cooling but continues to heat the DHW tank.
Heat	Space heating and DHW tank heating.
Cool	Space cooling only. See DHW section for DHW operation.
Auto	The system automatically switches between heating and cooling.
Emergency	Space heating using backup boilers only. The heat pumps are not operated.

Mode Synchronization

In tekmarNet systems, the 291 synchronizes its mode setting with the mode setting on all thermostats. This allows the mode to be selected from any heat-cool thermostat without the need to go to the mechanical room.

Auto Mode

In auto mode, the 291 automatically switches between heating and cooling. When the outdoor air temperature is above the Warm Weather Shut Down the system provides cooling. When the outdoor air temperature is below the Cold Weather Shut Down, the system provides heating. When the outdoor air temperature is in between the Warm and Cold Weather Shut Down settings, the auto mode operation is dependent on the use of local or tekmarNet calls.

Auto Mode with Local Calls

If there is both a hot tank and a cold tank call, the control uses the Heat Pump Priority setting to select the higher priority call.

Auto Mode with tekmarNet

In a tekmarNet system, each heat-cool thermostat sends a vote to the 291 on the preferred heat or cool operation based upon the thermostat's heat and cool setpoints and the ambient room temperature. The 291 chooses the operation that has 51% or greater votes. A 50% tie will result in no change to the current operation.

Heat-Cool Interlock

In auto mode, the control must wait for the heat-cool interlock time to elapse before switching between heating and cooling.

If the tank is heating it will not switch to cooling until the heat-cool interlock time has elapsed and there has been zero heating calls during that time.

If the tank is cooling it will not switch to heating until the heat-cool interlock time has elapsed and there has been zero cooling calls during that time.

Post Purge Operation

In a tekmarNet system, the control completes a post purge to any zones that require heating or cooling. The post purge is limited to 5 minutes, after which the heat-cool switchover starts.

Pre-Heat Operation

After switching to heating, the control prevents the hot tank pump from operating until the tank is 10°F (4.5°C) below the tank target. This prevents sending cold water to the heating zones.

Pre-Cool Operation

After switching to cooling, the control prevents the hot tank pump from operating until the tank is 10°F (4.5°C) above the tank target. This prevents sending hot water to the cooling zones.

4-Pipe Operation

In a 4-pipe system, the hot tank is heated, and the cold tank is cooled to reach their targets. The hot tank is not heated during Warm Weather Shut Down and the cold tank is not cooled during Cold Weather Shut Down.

Heat Pump Groups and Staging

In a 4-pipe operation, the control automatically assigns all available heat pumps into heating and cooling groups based upon their accumulated running hours. When first started, odd number heat pumps are assigned to the heating group and even number heat pumps are assigned to the cold group. Heat pumps in the heating group provide heat to the hot tank and heat pumps in the cooling group provide cooling to the cold tank. This reduces heat pump reversing valve switchover to improve temperature control and reduce mechanical wear on the reversing valve.

When there is both a hot tank and cold tank call, once all heat pumps in the heating group have turned on and the cold tank target is within ½ differential, heat pumps from the cold tank group that are not running are re-assigned to the hot tank group based upon the highest running hours.

Conversely, when there is both a hot tank and cold tank call, once all heat pumps in the cold tank group have turned on and the hot tank target is within ½ differential, then heat pumps from the hot tank group that are not running can be re-assigned to the cold tank group based upon the highest running hours.

This allows all heat pumps to be dynamically assigned to the highest heating or cooling load and optimize comfort within the building.

Diverting Valve Operation

In a 4-pipe system, when a heat pump is operating, the hot or cold water must be directed to the appropriate buffer tank using a 6-way or pairs of 3-way diverting valves. The control supports two options:

Diverting Valves Per Heat Pump

Each heat pump has its own set of diverting valves. The diverting valves are synchronized with the heat pump's O/B relay.

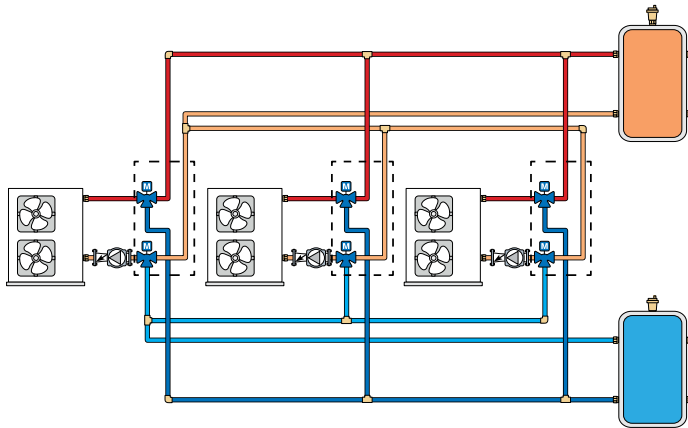

Diverting Valves Per Group

There is a single set of diverting valves for all heat pumps. This forces all the heat pumps to operate in the heating or cooling mode.

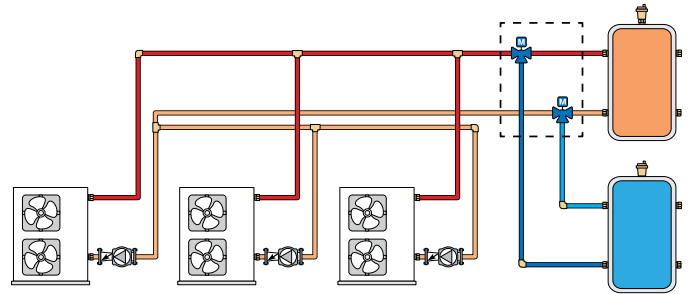

Loops

The control operates the following hydronic loops:

Heat Pump Loop

The heat pump loop provides hot or chilled water to the buffer tanks. A single condensing boiler can be added to this loop to provide backup heat. The Hot Heat Pump Return sensor protects the heat pump pumps from refrigerant high-pressure lockouts by shutting off the heat pumps if the heat pump loop is too hot during heating mode (Heat Pump Return Maximum) and shuts off heat pumps when too cold during cooling mode (Heat Pump Return Minimum).

Hot Tank Loop

The hot tank loop distributes hot water to the hydronic heating zones.

Boiler Loop

In cases where the boiler has dedicated loads such as domestic hot water tank heating or snow melting or there are multiple backup boilers, a tekmar Smart Boiler Control 294 is required in tandem with the Smart Heat Pump Control 291. The 294 operates the boilers based upon the heating calls.

Transfer Pump

A transfer pump is used to move heat from a boiler loop to either the heat pump loop or to tank loop.

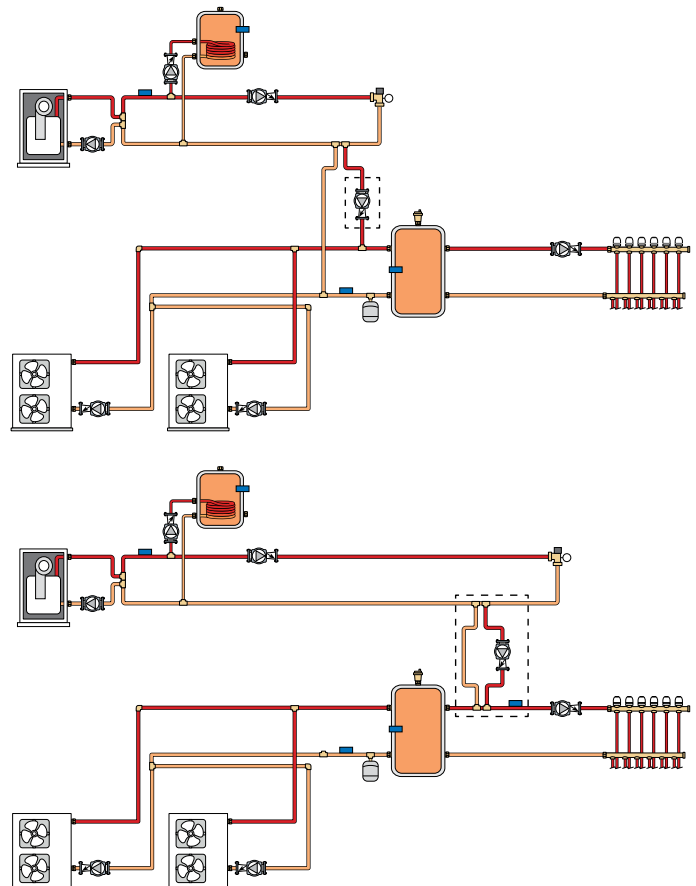

Mix Loops

The 291 operates up to three mix loops to lower the temperature for heating and to raise the temperature in cooling. Mixing allows the use of different heating/cooling curves that are suited to the type of heat emitter such as fan coils, baseboard, radiators, staple-up and in-floor radiant heating.

Each mix loop is regulated by a Smart Mix Expansion 295 that provide an analog 0-10 V(dc), analog 4-20 mA or 24 V(ac)

floating action signal to an actuator that adjusts the position of a 3-way or 4-way mixing valve. The mix expansion controls also support variable speed injection mixing signals to compatible wet rotor circulators. Please refer to Essay E021 for more information on variable speed injection pump mixing.

DHW Tank Operation

DHW Call

A domestic hot water (DHW) call operates the heat pumps or boilers at a fixed temperature to heat a DHW storage tank. The DHW call status is displayed in the System Inputs on the display. A DHW call can be created in one of three ways:

DHW Tank Aquastat

If a DHW tank aquastat (mechanical switch) is used to apply a DHW Call, the tank is heated to the aquastat temperature setting. A dry contact or 24 V (ac) signal is applied across the DHW Call Terminals.

DHW Sensor

A DHW Tank Sensor 078 (not included) is installed in a temperature well to measure the tank temperature. A DHW call is created when the tank temperature falls to the DHW Tank Occupied minus the DHW Differential. The DHW call is removed when the tank reaches the DHW Tank Occupied setpoint.

tekmarNet Setpoint Control

A DHW call can be provided through the tekmarNet system by using a tekmarNet Setpoint Control.

DHW Tank Position

The DHW tank can be in four different positions within the system. The position of the DHW tank will determine when it's heated by the heat pumps and when backup and/or supplementary heating is required.

DHW Tank on the Heat Pump Loop

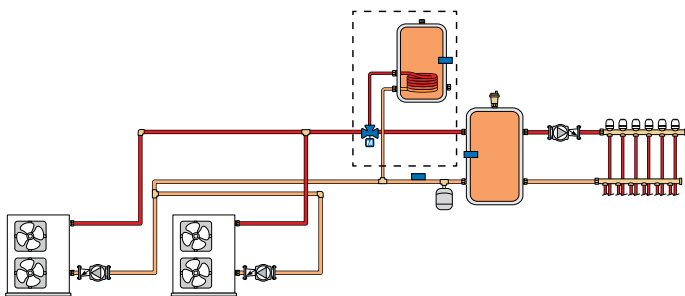

In this configuration, a 3-way valve is required to divert hot water to the DHW tank. This allows DHW tank heating while the space heating system is in cooling mode.

DHW Tank on Backup Boiler Side Arm

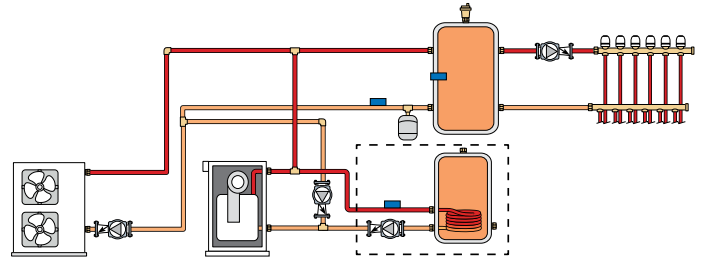

In this configuration, the indirect DHW tank is piped in parallel within the near boiler piping of the single backup boiler. A DHW tank aquastat is used to create the DHW call, and a DHW sensor is used to regulate the boiler heat exchange water temperature, to prevent the boiler from tripping on its internal maximum temperature limit. When a DHW call is present, the DHW pump turns on and the boiler pump turns off. This piping configuration provides simultaneous central heating and DHW tank heating with the DHW tank having the full capacity of boiler heating output.

Once the DHW tank call is satisfied, the boiler is shut off and there is a 2-minute DHW pump post purge, after which the single backup boiler is available to resume heating the hot tank if required.

DHW Tank on the Hot Tank Loop

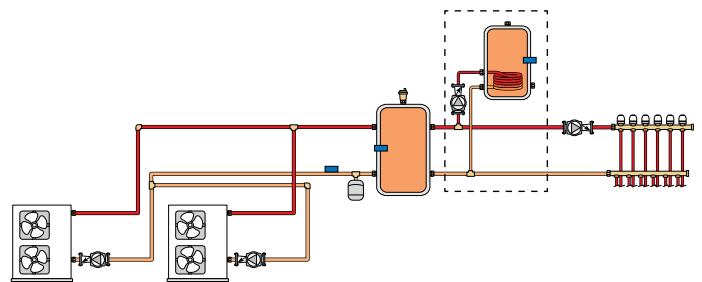

The indirect DHW tank is piped in the hot tank loop. When a DHW call is present, the DHW Pump turns on.

DHW With Hot Tank Pump

Off

The hot tank pump does not turn on during indirect DHW operation. Select Off when an indirect DHW tank is piped in parallel to the central heating system and located on the hot tank loop.

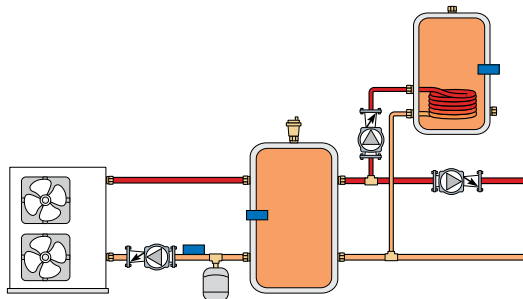

On

The hot tank pump turns on during indirect DHW operation. Select On when the indirect DHW tank piped is piped in primary/secondary to the hot tank loop.

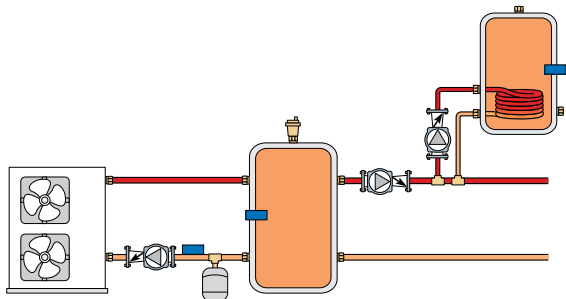

DHW Priority

The DHW Priority setting selects priority over the hot tank loop space heating. This allows for quick recovery of the indirect DHW tank.

Off

DHW priority is not provided. The hot tank pump operates when a Hot Tank call is present.

On

When there are simultaneous DHW and hot tank calls, the hot tank pump shuts off to provide priority to the DHW tank.

When there are simultaneous DHW and tekmarNet calls, the hot tank pump can continue to operate. If the heat pumps or boiler are unable to maintain the hot tank target temperature, the tekmarNet zones are sequentially shut off using tekmarNet communication to provide priority. The sequence order shuts off the thermostat with address 24 first and address 1 last.

Priority Override

The control includes an Indirect DHW Priority Override to prevent the building from cooling off too much or a potential freezing condition in the event of a faulty DHW aquastat or sensor. The time is adjustable from 20 to 240 minutes. Once the allowed time for priority has elapsed, the control overrides the DHW priority and resumes central heating. DHW Priority does not resume until the central heating or DHW call is removed and then reapplied.

DHW Tank on Boiler Loop

In this configuration, the DHW tank is heated by the boilers that are operated by the Smart Boiler Control 294. See the IOM-T-294 for details.

Heat Pump Operation

The control can operate 4 onboard heat pumps and up to 16 heat pumps when used together with three Smart Heat Pumps 291EXP. Each heat pump is configured individually to provide maximum flexibility.

Heat Pump Availability

Select the heat pump available to On to allow the heat pump to be part of the staging sequence. Select Off if the heat pump is being serviced or that heat pump output is not used.

Heat Pump Manufacturer, Series and Model

The control includes presets for many heat pump models, both geo exchange and air source. Select the manufacturer, series, and then the model and the control will load the recommended presets for that specific heat pump. The heat pump settings can be changed if desired.

If the manufacturer, series or model of your boiler is not available, then set the Heat Pump Manufacturer to Custom. tekmar is

continually updating the supported heat pump presets which is automatically updated when the control is connected to the Internet. It is recommended to connect the control to the Internet first if your heat pump model is not available when first powered on.

Source

Select between air source or geo exchange heat pumps. Air source heat pumps experience a decline in efficiency and heat output during cold outdoor weather. When air source heat pumps are selected, an optional balance point setting is available to disable the heat pump during cold outdoor air temperature.

Heat Pump Fuel

The control allows the selection of the heat pump's energy. While most heat pumps are electric, gas absorption heat pumps that use natural gas or propane as fuel are available.

Heat Pump Type

The control supports 1-stage and 2-stage heat pumps. When 1-stage is selected, each heat pump stage is mapped to the corresponding stage output wiring terminals. Example: Heat Pump 1 is mapped to Stage 1 terminals.

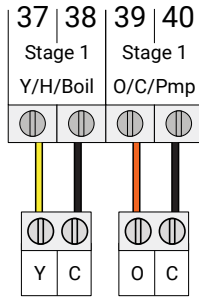

When 2-stage is selected, the stage operates the corresponding stage and the following stage. Example: Heat Pump 2 is selected to be 2-stage. The first stage is mapped to the Stage 2 terminals and the second stage is mapped to the Stage 3 terminals.

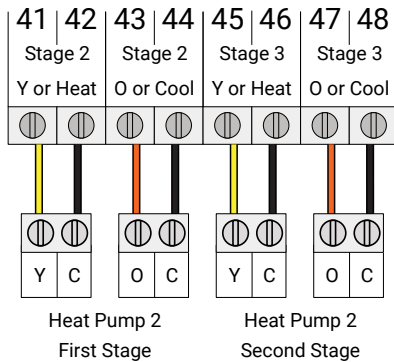

Please note that 2-stage heat pumps are not allowed to span across the Smart Heat Pump Control 291 and the Smart Heat Pump Expansion 291EXP or between two 291EXP.

Heat Pump Electrical Input

The electrical power used by the heat pump can be entered in the units of Watts and is used for electrical utility load shedding programs. This setting is automatically entered when using the heat pump preset feature.

To manually calculate the approximate power used for single phase electrical heat pumps, multiply the heat pump voltage by the compressor Rated Load Amps (RLA). This calculation assumes a power factor of 1.

Example: If the heat pump is rated at 230 V(ac), single phase, and compressor RLA 33.3 amps, then the approximate power is $230V \times 30A = 6900W$.

For three phase heat pumps, multiply the voltage and the Rated Load Amps (RLA) by $\sqrt{3}$. This calculation assumes a power factor of 1.

Example: $230V \times 30A \times \sqrt{3} = 11951W$.

Gas Input

When an absorption heat pump is installed, the power rating of the heat pump is entered using the MBU/hr of the gas burner.

2-Pipe Heat Pump Staging

In this configuration, the control stages the heat pumps on and off to meet the tank target.

4-Pipe Heat Pump Staging

Diverting Valve per Heat Pump

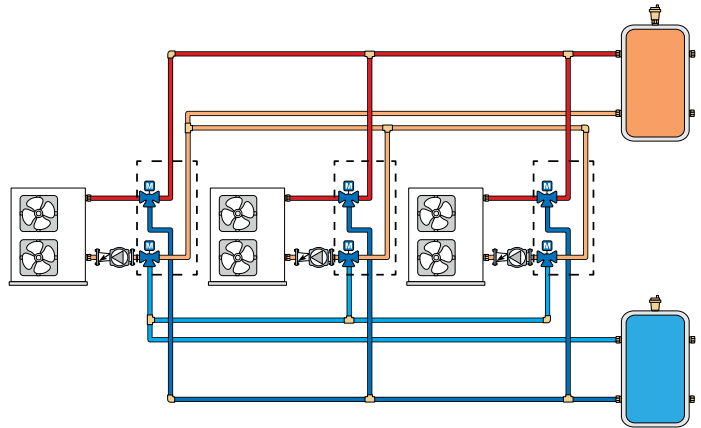

In this configuration, the control uses a patent-pending algorithm to simultaneously provide heating and cooling to the HVAC system. The control assigns the available heat pumps between heating and cooling groups based upon run time.

The control stages the heat pumps in the heating group to reach the hot tank setpoint and stages the heat pumps in the cooling group to reach the cold tank setpoint. Once the hot or cold tank reaches the target, then heat pumps can automatically be assigned to the other group. If the tank temperature drops $\frac{1}{2}$ differential below the target, it may switch back to its original assigned group. This allows the heat pumps to dynamically shift between the heating and cooling groups to meet the storage tank setpoints.

Once one heat pump accumulates 48 hours more running hours than the heat pump with the least running hours, the heat pumps are reassigned to the heating and cooling groups based upon their accumulated run time. This rebalances the run time to ensure equal wear on heat pumps in the plant. If heat pumps are operating, the control will wait up to an additional 12 hours before forcing all heat pumps off to complete the rotation sequence.

Diverting Valves per Group

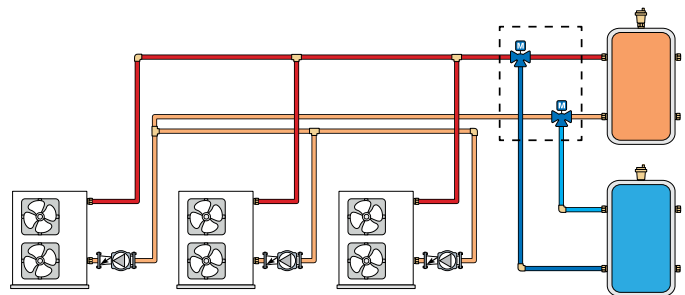

In this configuration, all the heat pumps are assigned to the heating group, or the cooling group and the heat pumps are staged on and off to maintain the tank target. When there is both heating and cooling calls at the same time, the control responds to the first call received. When the tank reaches the target, all the heat pumps shut off and are assigned to the opposite tank target.

Heat Pump Staging

The first stage heat pump is turned on ½ differential below the target and shuts off ½ differential above the target. Additional heat pump stages are turned on based upon PID staging. This includes the amount of temperature differential below the target (Proportional) and the amount of time the temperature is below the target (Integral).

The control also includes a stage delay time that must elapse before the next heat pump stage is allowed to turn on, a minimum run time for the heat pump compressor, and a minimum off time to allow the heat pump refrigerant to cool down. Combined, these features reduce short cycling that results in compressor damage and improve heat pump efficiency.

Heat Pump Return Minimum and Maximum

The heat pump must be protected from excessively high or low temperature that can lead to a refrigerant high-pressure lock-out on the compressor. In 2-pipe configurations, the hot tank return sensor provides a heat pump return minimum and maximum temperature limit that shuts off the heat pump compressor. In 4-pipe configurations, the heat pump return maximum applies to the hot tank and the heat pump return minimum applies to the cold tank. The heat pump compressor is allowed to turn back on when the temperature is 1°F (0.5°C) above the return minimum temperature or 1°F (0.5°C) below the return maximum temperature.

Heat Pump Relays

The control includes relay logic to operate the heat pump reversing valve and compressor. The relays are isolated and designed for 230 V(ac), 5 A. In most cases these can be wired directly to the heat pump without the use of isolation relays. The heat pump presets automatically configure the Heat Pump Relay to the correct setting.

Heat Pump Relay Setting	Operation
Y+O	Reversing valve O is open in heating mode and closed in cooling mode. Y relay turns on the heat pump compressor.
Y+B	Reversing valve B is closed in heating mode and open in cooling mode. Y relay turns on the heat pump compressor.
Heat-Cool	Heat relay is closed during heating, Cool relay is closed during cooling.

Equal Run Time Rotation

In a 4-pipe system the control maintains separate rotation groups for heating and cooling groups. In 2-pipe systems, there is only one rotation group.

The Rotate feature changes the staging order of the heat pumps whenever one heat pump accumulates 48 hours more run time than any other heat pump in a group. Rotation will be forced if any heat pump accumulates 60 hours more run time. After each rotation, the heat pump with the least running hours is the first to run and the heat pump with the most running hours is the last to stage on. This function ensures that all the heat pumps receive equal amounts of use. When Rotation is Off, the staging sequence always begins with lowest heat pump stage to the highest heat pump stage.

Backup Boiler Operation

Backup boilers can be optionally installed to provide supplementary heat or full substitution of the heat pump capacity for balance point or electrical utility dual fuel programs. A single backup boiler may be installed in parallel with the heat pumps to the hot tank. In cases where there are two or more boilers, or if there are heating loads on the boiler loop, such as high temperature fan coils or snow melt systems, this requires a boiler loop and the addition of a Smart Boiler Control 294.

Single Backup Boiler

The control can operate a single boiler in parallel with the heat pump to heat the hot storage tank. The backup boiler is wired to the Stage 1 output. The control will automatically adjust the backup boiler to be at the end of the staging sequence unless the heat pumps are forced off due to the heat pump return minimum or maximum temperature, balance point or dual fuel operation.

Single Boiler

The control provides signals for a boiler on-off enable; an analog 0 to 10 V(dc) or 4 to 20 mA signal to adjust the firing rate or boiler operating temperature; and a 120 V(ac) signal to the boiler pump.

Due to the boiler being in parallel with the heat pumps, it is recommending installing a condensing boiler that operates at low temperature.

Boiler Available

Select the boiler available to On to allow the boiler to be part of the staging sequence. Select Off if the boiler is being serviced or that boiler output is not used.

Boiler Manufacturer, Series and Model

The 291 includes presets for over 1600 boiler models. Select the manufacturer, series and then the model and the control loads the recommended presets for that specific boiler. The boiler settings can be changed if desired.

If the manufacturer, series or model of your boiler is not available, then set the Boiler Manufacturer to Custom.

tekmar is continually updating the supported boilers presets which is automatically updated when the control is connected to the Internet. It is recommended to connect the control to the Internet first if your boiler model is not available when first powered on.

Boiler Fuel

Select the type of fuel used by the boiler.

Boiler Type

When configuring a Custom boiler, the Boiler Type offers four different options to choose from:

1) 1-Stage

This setting operates a one-stage boiler and is available in all configurations. The Boiler Status displays 100% when the boiler is on and 0% when the boiler is off.

2) Electric Water Heater

The control stages the water heater on and off based upon the differential.

3) Modulating Target Temp

The modulating output operates a boiler that interprets an analog input signal as a target temperature. The Output EMS Signal Minimum sets the starting voltage. The EMS Temperature Minimum sets the starting target temperature. The EMS Temperature Maximum sets the maximum target temperature.

The home screen Boiler tab displays the boiler target temperature when the boiler is on and displays “- -” when the boiler is off.

4) Modulating Firing Rate

The modulating output operates a modulating boiler by controlling the burner firing rate. The Boiler Enable relay is also used to give a boiler enable to allow the modulating boiler to go through the ignition sequence. The boiler enable relay may not be necessary. Please consult the boiler manual to wiring information.

The home screen Boiler tab displays the boiler firing rate when modulating the boiler from 0 to 100% output.

Modulation Type

Select the modulating output to be either 0-10 V (dc) or 4-20 mA. A 4-20 mA output can be converted to a 0 - 135 Ω output using a tekmar 0 - 135 Ω Converter 005.

Fire Delay

The Fire Delay is the ignition delay time of the boiler, from when the boiler enable contact is closed until when a flame is established. The Fire Delay can be found in the boiler manual or can be timed with a watch.

Modulation Delay

After the flame is established, some boilers require the firing rate to hold at low fire before the firing rate can change. Set this time as the Modulation Delay.

Boiler Mass

The Boiler Mass setting selects the thermal mass characteristics of each boiler. Operation of the boiler can become unstable if the incorrect Boiler Mass setting is chosen. A key sign of unstable boiler operation is that the flame will continue to increase and then decrease in short periods of time.

Low

Select Low mass for smaller sized boilers. This provides short pre purge times for the pumps, modulates the boiler firing rate at a slow rate, and operates the boiler staging with shorter inter-stage delays.

Medium

Select Medium mass for medium sized boilers. This provides moderate pre purge times for the pumps, modulates the boiler firing rate at a moderate rate, and operates the boiler staging with moderate inter-stage delays.

High

Select High mass for large commercial boilers. This provides long pre and post purge times for the pumps, modulates the boiler quickly, and operates the boiler staging with long inter-stage delays.

Very High

Select ‘Very High’ mass for large commercial boilers that are overshooting with the High mass setting.

Boiler Low and High Output

To accommodate different boiler capacities in the same system, a low fire and high fire boiler output for each boiler is available. This allows the control to properly operate the boilers using either sequential or parallel modulation. Each boiler typically has a rating plate that specifies the minimum and maximum output. This information is also available in the boiler manual.

The minimum and maximum boiler output is entered in units of MBTU/hr. 1 MBTU / hr = 1,000 Btu per hour. The range is from 10 to 9990 MBTU/hr.

Modulation Motor Speed

The Modulation Motor Speed is the amount of time the analog modulating output signal to the boiler requires to go from 0% to 100% modulation.

Boilers with an electronic blower fan are recommended to use the factory default of 30 seconds.

Boilers with a modulating motor gas valve and linkage arms should set the Modulating Motor Speed to the time required to fully open the gas valve.

Start Modulation

The Start Modulation setting is the lowest modulation output required to obtain proper ignition.

Minimum Modulation

The Minimum Modulation is the lowest signal the control can send to modulate the boiler and operates the boiler at low fire. Refer to the boiler manufacturer’s literature to determine the minimum output voltage V (dc) or current (mA) that the boiler will successfully operate at.

Boiler Post Purge

The boiler pump operates for a period of time after the boiler is turned off to purge heat out of the boiler, reducing stand-by losses, and also reduces “kettling” on low mass boilers. The amount of time for the boiler pump post purge is adjustable between 0 to 40 minutes.

Boiler Loop

When there are multiple backup boilers, or the backup boiler provides heating to loads other than the hot storage tank, then a Boiler Loop operated by a tekmar Smart Boiler Control 294. In this configuration, the 291 tekmarNet Bus 4 is connected to the 294 tekmarNet boiler bus.

Backup Delay

The control includes a backup delay. After all available heat pumps are staged on, the backup delay must elapse before the backup boiler is staged on.

Transfer Pump Operation

The control operates a transfer pump to move heat from the boiler loop to the either the heat pump loop or the hot tank loop. The transfer pump shares the DHW/Xfer pump relay with the DHW operation. DHW operation must be disabled in order to use the transfer pump.

The transfer pump can be on-off or variable speed using an analog 0 to 10 V(dc) or 4 to 20 mA signal. When set to on-off, the transfer pump is cycled using an adjustable differential to maintain the hot tank loop target. When the transfer pump is on it creates a tekmarNet boiler call to the 294.

Pump Operation

Hot Tank Pump

In 2-pipe configuration, the hot tank pump is used to provide flow in both heating and cooling modes.

In 4-pipe configuration, the hot tank pump operates when there is a local or tekmarNet call and the system is not in a special condition such as warm weather shut down.

Cold Tank Pump

In 2-pipe configuration, the cold tank pump output is closed to provide an interlock to disable heating calls while the system is in cooling. This can be used to disable non-tekmarNet heating calls. In tekmarNet systems, the heat-cool interlock is done automatically through communication.

In 4-pipe configuration, the cold tank pump operates when there is a local or tekmarNet call and the system is not in a special condition such as cold weather shut down.

Mix 1, 2, 3 System Pump

The mix system pump operates when there is a local or tekmarNet call for heat and the system is not in warm weather shut down. The mix system pump also operates when tekmarNet thermostat's call for radiant floor cooling.

Exercising

The control has the option to exercise all pumps and tekmarNet zones (zone valves and zone pumps) for 10 seconds every three days of inactivity to prevent seizure. This is selected by setting Exercising to On.

Occupancy Schedule

The control includes a 4-event, 7-day programmable schedule to provide additional energy savings for systems that do not use programmable thermostats such as Thermostatic Radiator Valves (TRV) or constant circulation hydronic systems. The schedule is stored in memory and is not affected by loss of power to the control.

The 4-events available per day are: Occupied 1, Unoccupied 1, Occupied 2 and Unoccupied 2. Each outdoor reset heating and cooling curve includes a Room Occupied and Room Unoccupied settings that shifts the target up or down based upon the occupancy schedule. In addition, the Warm Weather Shut Down and Cold Weather Shut Down features include Occupied and Unoccupied settings to prevent different shut down temperatures based upon the programmable schedule.

Dual Fuel

A dual fuel system is a hybrid system with both an electric heat pump and a fossil fuel boiler. In normal operation, the control stages the heat pumps to meet the heating load, and the fossil fuel boilers are staged on only when all available heat pumps are on and unable to meet the heating load. For economic reasons, it may be beneficial to shut off the electric heat pumps and switch to fossil fuel backup boilers.

The control displays an electric symbol on the home screen when prioritizing electric heat pumps and a slash through the electric symbol when in fossil fuel operation.

Balance Point

Air-to-water heat pumps have lower efficiency and lower heating capacity when the outdoor air temperature falls. The balance point sets the outdoor air temperature at which the heat pumps are no longer used, and all heating is done using fossil fuel boilers. The control locks out the heat pumps when the outdoor air temperature is below the balance point setpoint and allows the heat pumps to operate when the outdoor air temperature is 1°F (0.5°C) above the balance point setpoint.

Dual Fuel Schedule

Some electrical utilities offer lower rates based upon a time-of-day schedule. The control supports a dual fuel schedule that allows the configuration of an on-peak (high electrical rate) and off-peak (low electrical rate) schedule, with up to 4-events per day, 7-day schedule. During on-peak time periods the heat pumps are shut off and the backup fossil fuel boilers provide heating. During off-peak time periods the heat pumps are the first to stage on.

Dual Fuel Call

Some electrical utilities offer lower rates based upon a signal that operates an electrical relay. The control accepts a dual fuel call from an electrical relay contact closure or a 24 V(ac) signal. When a dual fuel call is present, the control shuts off the electric heat pumps and the backup fossil fuel boilers provide heating. When the dual fuel call is removed, the heat pumps are the first to stage on.

Time Clock

When connected to the Internet, the control automatically sets its time to the Eastern time zone by default. This can be changed to one of the applicable North American time zones. By default, Daylight Savings Time is On. Select Daylight Savings Time to Off for regions that do not observe daylight savings time.

If the Internet is not available, the control includes a built-in time clock to allow the control to operate on a schedule. A battery-less backup allows the control to keep time for up to 4 hours without power. The time clock supports automatic adjustment for Daylight Saving Time (DST) once the day, month, and year are entered.

Troubleshooting

It is recommended to complete all wiring to ensure trouble-free operation. Should an error occur, simply follow these steps:

1. **Find:** If a banner is on the screen, it indicates a problem on the system.
2. **Identify:** Press the ☰ icon on the top right corner to enter the menus and press notifications. The latest error notification will appear at the top of the list.
3. **Solve:** The notification description provides the instructions on the corrective action required to clear the error.

Errors and Alerts (1 of 7)

Error Title	Description
Control Memory Error	A memory error has been detected. The control will not operate the boilers until all settings have been reviewed. You may also reload factory defaults and use the Setup Wizard to configure the control. If the memory error keeps recurring after a power outage, the control may require replacement. Consult technical support for assistance.
Hardware Fault	The main MCU detected a problem with a peripheral such as memory, Wi-Fi radio or Thread radio.
Hot Tank Short Error	A short circuit is detected on the hot tank temperature sensor input. The control uses the hot heat pump return sensor to operate the heat pumps until this fault is corrected. To correct, remove the wires from the hot tank sensor terminals, then use an electrical multimeter to measure the resistance. The resistance should be proportional to the temperature lookup table in the Installation and Operation Manual. Check the wires for damage. If the wires are OK, then replace.
Hot Tank Open Error	An open circuit is detected on the hot tank temperature sensor input. The control uses the hot heat pump return sensor to operate the heat pumps until this fault is corrected. To correct, remove the wires from the hot tank sensor terminals, then use an electrical multimeter to measure the resistance. The resistance should be proportional to the temperature lookup table in the Installation and Operation Manual. If the resistance is open circuit, check the wires for loose wiring connections. If the wires are OK, then replace the Universal Sensor 082. Once the fault is corrected, the error clears automatically.
Cold Tank Short Error	A short circuit is detected on the cold tank temperature sensor input. The control uses the cold heat pump return sensor to operate the heat pumps until this fault is corrected. To correct, remove the wires from the cold tank sensor terminals, then use an electrical multimeter to measure the resistance. The resistance should be proportional to the temperature lookup table in the Installation and Operation Manual. Check the wires for damage. If the wires are OK, then replace the Universal Sensor 082. Once the fault is corrected, the error clears automatically.
Cold Tank Open Error	An open circuit is detected on the cold tank temperature sensor input. The control uses the cold heat pump return sensor to operate the heat pumps until this fault is corrected. To correct, remove the wires from the cold tank sensor terminals, then use an electrical multimeter.
Hot Heat Pump Return Short Error	A short circuit is detected on the hot heat pump return temperature sensor input. The control uses the hot tank sensor to operate the heat pumps until this fault is corrected. To correct, remove the wires from the hot tank return sensor terminals, then use an electrical multimeter to measure the resistance. The resistance should be proportional to the temperature lookup table in the Installation and Operation Manual. Check the wires for damage. If the wires are OK, then replace the Universal Sensor 082. Once the fault is corrected, the error clears automatically.
Hot Heat Pump Return Open Error	An open circuit is detected on the hot tank return temperature sensor input. The control uses the hot heat pump sensor to operate the heat pumps until this fault is corrected. To correct, remove the wires from the hot heat pump return sensor terminals, then use an electrical multimeter to measure the resistance. The resistance should be proportional to the temperature lookup table in the Installation and Operation Manual. If the resistance is open circuit, check the wires for loose wiring connections. If the wires are OK, then replace the Universal Sensor 082. Once the fault is corrected, the error clears automatically.

Errors and Alerts (2 of 7)

Error Title	Description
Cold Heat Pump Return Short Error	<p>A short circuit is detected on the cold heat pump return temperature sensor input. The control uses the cold tank sensor to operate the heat pumps until this fault is corrected.</p> <p>To correct, remove the wires from the cold tank return sensor terminals, then use an electrical multimeter to measure the resistance. The resistance should be proportional to the temperature lookup table in the Installation and Operation Manual. Check the wires for damage. If the wires are OK, then replace the Universal Sensor 082. Once the fault is corrected, the error clears automatically.</p>
Cold Heat Pump Return Open Error	<p>An open circuit is detected on the cold tank return temperature sensor input. The control uses the cold heat pump sensor to operate the heat pumps until this fault is corrected.</p> <p>To correct, remove the wires from the cold heat pump return sensor terminals, then use an electrical multimeter to measure the resistance. The resistance should be proportional to the temperature lookup table in the Installation and Operation Manual. If the resistance is open circuit, check the wires for loose wiring connections. If the wires are OK, then replace the Universal Sensor 082. Once the fault is corrected, the error clears automatically.</p>
Mix 1 Sensor Short Error	<p>A short circuit is detected on the mix temperature sensor input located on the Mix 1 Expansion. The control will not operate the mixing system until this fault is corrected.</p> <p>To correct, remove the wires from the mix sensor terminals, then use an electrical multimeter to measure the resistance. The resistance should be proportional to the temperature lookup table in the Installation and Operation Manual. Check the wires for damage. If the wires are OK, then replace the Universal Sensor 082. Once the fault is corrected, the error clears automatically.</p>
Mix 1 Sensor Open Error	<p>An open circuit is detected on the mix temperature sensor input located on the Mix 1 Expansion. The control will not operate the mixing system until this fault is corrected.</p> <p>To correct, remove the wires from the mix sensor terminals, then use an electrical multimeter to measure the resistance. The resistance should be proportional to the temperature lookup table in the Installation and Operation Manual. If the resistance is open circuit, check the wires for loose wiring connections. If the wires are OK, then replace the Universal Sensor 082. Once the fault is corrected, the error clears automatically.</p>
Mix 2 Sensor Short Error	<p>A short circuit is detected on the mix temperature sensor input located on the Mix 2 Expansion. The control will not operate the mixing system until this fault is corrected.</p> <p>To correct, remove the wires from the mix sensor terminals, then use an electrical multimeter to measure the resistance. The resistance should be proportional to the temperature lookup table in the Installation and Operation Manual. Check the wires for damage. If the wires are OK, then replace the Universal Sensor 082. Once the fault is corrected, the error clears automatically.</p>
Mix 2 Sensor Open Error	<p>An open circuit is detected on the mix temperature sensor input located on the Mix 2 Expansion. The control will not operate the mixing system until this fault is corrected.</p> <p>To correct, remove the wires from the mix sensor terminals, then use an electrical multimeter to measure the resistance. The resistance should be proportional to the temperature lookup table in the Installation and Operation Manual. If the resistance is open circuit, check the wires for loose wiring connections. If the wires are OK, then replace the Universal Sensor 082. Once the fault is corrected, the error clears automatically.</p>
Mix 3 Sensor Short Error	<p>An open circuit is detected on the mix temperature sensor input located on the Mix 3 Expansion. The control will not operate the mixing system until this fault is corrected.</p> <p>To correct, remove the wires from the mix sensor terminals, then use an electrical multimeter to measure the resistance. The resistance should be proportional to the temperature lookup table in the Installation and Operation Manual. If the resistance is open circuit, check the wires for loose wiring connections. If the wires are OK, then replace the Universal Sensor 082. Once the fault is corrected, the error clears automatically.</p>
Mix 3 Sensor Open Error	<p>An open circuit is detected on the mix temperature sensor input located on the Mix 3 Expansion. The control will not operate the mixing system until this fault is corrected.</p> <p>To correct, remove the wires from the mix sensor terminals, then use an electrical multimeter to measure the resistance. The resistance should be proportional to the temperature lookup table in the Installation and Operation Manual. If the resistance is open circuit, check the wires for loose wiring connections. If the wires are OK, then replace the Universal Sensor 082. Once the fault is corrected, the error clears automatically.</p>
Domestic Hot Water Sensor Short Error	<p>A short circuit is detected on the domestic hot water temperature sensor input. The control will not heat the domestic hot water tank until this fault is corrected.</p> <p>To correct, remove the wires from the DHW sensor terminals, then use an electrical multimeter to measure the resistance. The resistance should be proportional to the temperature lookup table in the Installation and Operation Manual. If the resistance is short circuit, check the wires for damage. If the wires are OK, then replace the Universal Sensor 078. Once the fault is corrected, the error clears automatically.</p>

Errors and Alerts (3 of 7)

Error Title	Description
Domestic Hot Water Sensor Open Error	<p>An open circuit is detected on the domestic hot water temperature sensor input. The control will not heat the domestic hot water tank until this fault is corrected.</p> <p>The DHW sensor is optional, and the setting incorrectly turned on. Check if a sensor is installed. If not installed, set DHW Sensor to off. If installed, remove the wires from the DHW sensor terminals, then use an electrical multimeter to measure the resistance. The resistance should be proportional to the temperature lookup table in the Installation and Operation Manual. If the resistance is open circuit, check the wires for loose wiring connections. If the wires are OK, then replace the Universal Sensor 078. Once the fault is corrected, the error clears automatically.</p>
Transfer Sensor Short Error	<p>A short circuit is detected on the transfer temperature sensor input. The control will not operate the boiler loop until this fault is corrected.</p> <p>To correct, remove the wires from the Transfer sensor terminals, then use an electrical multimeter to measure the resistance. The resistance should be proportional to the temperature lookup table in the Installation and Operation Manual. If the resistance is short circuit, check the wires for damage. If the wires are OK, then replace the Universal Sensor 082. Once the fault is corrected, the error clears automatically.</p>
Transfer Sensor Open Error	<p>An open circuit is detected on the transfer temperature sensor input. The control will not operate the boiler loop until this fault is corrected.</p> <p>To correct, remove the wires from the Transfer sensor terminals, then use an electrical multimeter to measure the resistance. The resistance should be proportional to the temperature lookup table in the Installation and Operation Manual. If the resistance is open circuit, check the wires for damage. If the wires are OK, then replace the Universal Sensor 082. Once the fault is corrected, the error clears automatically.</p>
Outdoor Sensor Short Error	<p>A short circuit is detected on the outdoor air temperature sensor input. The control will attempt to use the outdoor temperature from a tekmarNet system or from the Internet. If this is not available, the control operates the heating and cooling system at the heating and cooling design temperatures until this fault is corrected.</p> <p>To correct, remove the wires from the outdoor air sensor terminals, then use an electrical multimeter to measure the resistance. The resistance should be proportional to the temperature lookup table in the Installation and Operation Manual. If the resistance is short circuit, check the wires for damage. If the wires are OK, then replace the Outdoor Sensor 070. Once the fault is corrected, the error clears automatically.</p>
Outdoor Sensor Open Error	<p>An open circuit is detected on the outdoor air temperature sensor input. The control will attempt to use the outdoor temperature from a tekmarNet system or from the Internet. If this is not available, the control operates the heating and cooling system at the heating and cooling design temperatures until this fault is corrected.</p> <p>To correct, remove the wires from the outdoor air sensor terminals, then use an electrical multimeter to measure the resistance. The resistance should be proportional to the temperature lookup table in the Installation and Operation Manual. If the resistance is open circuit, check the wires for loose wiring connections. If the wires are OK, then replace the Outdoor Sensor 070. Once the fault is corrected, the error clears automatically.</p>
tekmarNet Outdoor Sensor Error	<p>The control has not received an outdoor temperature report from the tekmarNet network. The control will attempt to use the outdoor temperature from the Internet. If this is not available, the control operates the heating and cooling system at the heating and cooling design temperatures until this fault is corrected.</p> <p>Check the tekmarNet network for the location of the outdoor sensor measurement. Check the sensor for open or short circuits and replace the Outdoor Sensor 070 if necessary. Once the fault is corrected, the error clears automatically.</p>
Internet Outdoor Sensor Error	<p>The control has not received an outdoor temperature report from the Internet. Please check that your Router is not blocking Port 443. Please contact an IT professional if assistance is required.</p>
Expansion Communication Error	<p>The control has lost communication to all Heat Pump Expansion and/or Mix Expansion. All expansion controls will not operate until this error is corrected.</p> <p>To correct, check the expansion communication wires +, -, and Gnd on both the control and expansion to ensure the wire polarity is correct, the wire insulation is stripped, and the wire terminals are tight.</p>

Errors and Alerts (4 of 7)

Error Title	Description
Heat Pump Expansion 5 to 8 Lost Error	<p>The control has lost communication to the Heat Pump Expansion operating heat pumps 5 to 8. Heat pumps 5 through 8 will not operate until this error is corrected.</p> <p>To correct, check that the expansion power light is on. If the power light is off, use an electrical multimeter to check the power line and neutral terminals for 115 V(ac). If the expansion power light is on, then check the expansion communication wires +, -, and Gnd on both the control and expansion to ensure the wire polarity is correct, the wire insulation is stripped, and the wire terminals are tight.</p>
Heat Pump Expansion 9 to 12 Lost Error	<p>The control has lost communication to the Heat Pump Expansion operating heat pumps 9 to 12. Heat pumps 9 through 12 will not operate until this error is corrected.</p> <p>To correct, check that the expansion power light is on. If the power light is off, use an electrical multimeter to check the power line and neutral terminals for 115 V(ac). If the expansion power light is on, then check the expansion communication wires +, -, and Gnd on both the control and expansion to ensure the wire polarity is correct, the wire insulation is stripped, and the wire terminals are tight.</p>
Heat Pump Expansion 13 to 16 Lost Error	<p>The control has lost communication to the Heat Pump Expansion operating heat pumps 13 to 16. Heat pumps 13 through 16 will not operate until this error is corrected.</p> <p>To correct, check that the expansion power light is on. If the power light is off, use an electrical multimeter to check the power line and neutral terminals for 115 V(ac). If the expansion power light is on, then check the expansion communication wires +, -, and Gnd on both the control and expansion to ensure the wire polarity is correct, the wire insulation is stripped, and the wire terminals are tight.</p>
Mix 1 Expansion Lost Error	<p>The control has lost communication to the Mix 1 Expansion. The Mix 1 Expansion outputs will not operate until this error is corrected.</p> <p>To correct, check that the expansion power light is on. If the power light is off, use an electrical multimeter to check the power line and neutral terminals for 115 V(ac). If the expansion power light is on, then check the expansion communication wires +, -, and Gnd on both the control and expansion to ensure the wire polarity is correct, the wire insulation is stripped, and the wire terminals are tight.</p>
Mix Expansion 2 Lost Error	<p>The control has lost communication to the Mix 2 Expansion. The Mix 2 Expansion outputs will not operate until this error is corrected.</p> <p>To correct, check that the expansion power light is on. If the power light is off, use an electrical multimeter to check the power line and neutral terminals for 115 V(ac). If the expansion power light is on, then check the expansion communication wires +, -, and Gnd on both the control and expansion to ensure the wire polarity is correct, the wire insulation is stripped, and the wire terminals are tight.</p>
Mix Expansion 3 Lost Error	<p>The control has lost communication to the Mix 3 Expansion. The Mix 3 Expansion outputs will not operate until this error is corrected.</p> <p>To correct, check that the expansion power light is on. If the power light is off, use an electrical multimeter to check the power line and neutral terminals for 115 V(ac). If the expansion power light is on, then check the expansion communication wires +, -, and Gnd on both the control and expansion to ensure the wire polarity is correct, the wire insulation is stripped, and the wire terminals are tight.</p>
Mix 1 Configuration Error	<p>There is a configuration error with Mix 1. The alert is cleared when Mix 1 Expansion is detected, Mix 1 is enabled and one of tN4 Bus is assigned to Mix 1.</p>
Mix 2 Configuration Error	<p>There is a configuration error with Mix 2. The alert is cleared when Mix 2 Expansion is detected, Mix 2 is enabled and one of tN4 Bus is assigned to Mix 2.</p>
Mix 3 Configuration Error	<p>An error occurs when the Backup Type is set to Boiler Loop and a Mix 3 Expansion is detected on the expansion bus. This configuration is not permitted.</p>
tN4 Bus 1 Error	<p>Communication has been lost on tN4 Bus 1. Check the tN4, C and R wires for each tN4 device. Check the polarity of the C and R wires. Check for loose or broken wires. The error message self clears once the error condition is corrected.</p>
tN4 Bus 2 Error	<p>Communication has been lost on tN4 Bus 2. Check the tN4, C and R wires for each tN4 device. Check the polarity of the C and R wires. Check for loose or broken wires. The error message self clears once the error condition is corrected.</p>

Errors and Alerts (5 of 7)

Error Title	Description
tN4 Bus 3 Error	Communication has been lost on tN4 Bus 3. Check the tN4, C and R wires for each tN4 device. Check the polarity of the C and R wires. Check for loose or broken wires. The error message self clears once the error condition is corrected.
tN4 Bus 4 Error	Communication has been lost on tN4 Bus 4. Check the tN4, C and R wires for each tN4 device. Check the polarity of the C and R wires. Check for loose or broken wires. The error message self clears once the error condition is corrected.
tN4 Duplicate Master Error	Two tekmarNet buses are connected together which causes a communication failure. To correct, remove all tekmarNet wiring and reconnect one device at a time.
tN4 Boiler Control Lost Error	The tekmarNet communication to the boiler control is lost. To correct, ensure that there is power to the lost boiler control. Trace the wires from the control to the lost boiler control looking for loose or damaged wires. The error message self clears when the error condition is corrected. If the tN4 device is deliberately removed, go to the Reset menu and press tekmarNet Device Reset.
tN4 Device [bus number: device number] Lost Error	Communication is lost to tekmarNet device with this address. To correct, ensure that there is power to the lost device. Trace the wires from the control to the lost device looking for loose or damaged wires. The error message self clears when the error condition is corrected. If the tN4 device is deliberately removed, go to the Reset menu and press tekmarNet Device Reset.
tN4 Device [bus number: device number] Error	A tN4 thermostat or device with this address has an error that requires corrective action. Locate the tN4 device and troubleshoot using the device's Installation and Operating Manual.
Unsupported tN4 Device	An unsupported tN4 device is connected to tekmarNet communication network. This may include the Mixing Expansion Modules 440, 441, and 444. The error will clear automatically one this device is removed.
Ethernet Disconnected Error	The Ethernet is not connected to a network. Check the Ethernet cable connection to the control and the Router or Switch. Check that the Router or Switch is powered on and operating correctly.
Wi-Fi Invalid Password Error	The Wi-Fi Password was not accepted. Please check that the password was entered correctly. If necessary, please reconfigure your Wi-Fi network.
Wi-Fi Disconnected Error	The Wi-Fi network could not be found. Please check that the Wi-Fi network name was entered correctly, and that the Router signal is medium to high strength. If necessary, please reconfigure your Wi-Fi network.
DHCP Address Error	The router has not assigned the control an IP address. Please check the router's configuration settings and ensure that the DHCP server is enabled, and enough IP addresses are available. Please contact an IT professional for assistance.
Internet Unavailable Error	The control is unable to communicate to the Watts cloud through the Internet. The error will automatically clear once Internet communications are established. You may also set the Internet Connection Type to Off to clear the error. To correct: 1. Check the control's Internet DNS 1 and DNS 2 settings 2. Check that the router firewall is not blocking or filtering MAC addresses 3. Check that the router firewall is not blocking outbound port 23
Nexa Error	The control is unable to connect to the Nexa app. Please check that your router is not blocking outbound ports 443 or 8883. Please contact an IT professional for assistance.
Hot Tank No Heat Alert	The hot tank temperature did not achieve target within the hot tank alert time. There is likely a mechanical failure with either a heat pump or circulator that requires immediate attention. The control operates normally while this alert is present. To reset the alert, press the 'X' button to dismiss the error message on the home screen.

Errors and Alerts (6 of 7)

Error Title	Description
Cold Tank No Cool Alert	<p>The cold tank temperature did not achieve target within the cold tank alert time. There is likely a mechanical failure with either a heat pump or circulator that requires immediate attention. The control operates normally while this alert is present.</p> <p>To reset the alert, press the 'X' button to dismiss the error message on the home screen.</p>
Tank No Heat Alert	<p>The tank temperature did not achieve target within the heat pump alert time. There is likely a mechanical failure with either a heat pump or circulator that requires immediate attention. The control operates normally while this alert is present.</p> <p>To reset the alert, press the 'X' button to dismiss the error message on the home screen.</p>
Tank No Cool Alert	<p>The tank temperature did not achieve target within the heat pump alert time. There is likely a mechanical failure with either a heat pump or circulator that requires immediate attention. The control operates normally while this alert is present.</p> <p>To reset the alert, press the 'X' button to dismiss the error message on the home screen.</p>
Hot Tank High Temperature Alert	<p>The hot tank temperature exceeded the hot tank high temperature alert threshold. There is likely a mechanical failure with either a heat pump or circulator that requires immediate attention. The control operates normally while this alert is present.</p> <p>The alert clears when the hot tank temperature falls 2°F (1°C) below the hot tank high temperature alert threshold.</p>
Hot Tank Low Temperature Alert	<p>The hot tank temperature fell below the hot tank low temperature alert threshold. There is likely a mechanical failure with either a heat pump or circulator that requires immediate attention. The control operates normally while this alert is present.</p> <p>The alert clears when the hot tank temperature rises 2°F (1°C) above the hot tank low temperature alert threshold.</p>
Cold Tank High Temperature Alert	<p>The cold tank temperature exceeded the cold tank high temperature alert threshold. There is likely a mechanical failure with either a heat pump or circulator that requires immediate attention. The control operates normally while this alert is present.</p> <p>The alert clears when the cold tank temperature falls 2°F (1°C) below the cold tank high temperature alert threshold.</p>
Cold Tank Low Temperature Alert	<p>The cold tank temperature fell below the cold tank low temperature alert threshold. There is likely a mechanical failure with either a heat pump or circulator that requires immediate attention. The control operates normally while this alert is present.</p> <p>The alert clears when the cold tank temperature rises 2°F (1°C) above the cold tank low temperature alert threshold.</p>
Tank High Temperature Alert	<p>The tank temperature exceeded the tank high temperature alert threshold. There is likely a mechanical failure with either a heat pump or circulator that requires immediate attention. The control operates normally while this alert is present.</p> <p>The alert clears when the tank temperature falls 2°F (1°C) below the tank high temperature alert threshold.</p>
Tank Low Temperature Alert	<p>The tank temperature fell below the tank low temperature alert threshold. There is likely a mechanical failure with either a heat pump or circulator that requires immediate attention. The control operates normally while this alert is present.</p> <p>The alert clears when the tank temperature rises 2°F (1°C) above the tank low temperature alert threshold.</p>
Mix 1 High Temperature Alert	<p>The mix 1 temperature exceeded the mix 1 high temperature alert threshold. There is likely a mechanical failure with either a heat pump, boiler, valve or circulator that requires immediate attention. The control operates normally while this alert is present.</p> <p>The alert clears when the mix 1 temperature falls 2°F (1°C) below the mix 1 high temperature alert threshold.</p>
Mix 1 Low Temperature Alert	<p>The mix 1 temperature fell below the mix 1 low temperature alert threshold. There is likely a mechanical failure with either a heat pump, boiler, valve or circulator that requires immediate attention. The control operates normally while this alert is present.</p> <p>The alert clears when the mix 1 temperature rises 2°F (1°C) above the mix 1 low temperature alert threshold.</p>
Mix 2 High Temperature Alert	<p>The mix 2 temperature exceeded the mix 2 high temperature alert threshold. There is likely a mechanical failure with either a heat pump, boiler, valve or circulator that requires immediate attention. The control operates normally while this alert is present.</p> <p>The alert clears when the mix 2 temperature falls 2°F (1°C) below the mix 2 high temperature alert threshold.</p>

Errors and Alerts (7 of 7)

Error Title	Description
Mix 2 Low Temperature Alert	<p>The mix 2 temperature fell below the mix 2 low temperature alert threshold. There is likely a mechanical failure with either a heat pump, boiler, valve or circulator that requires immediate attention. The control operates normally while this alert is present.</p> <p>The alert clears when the mix 2 temperature rises 2°F (1°C) above the mix 2 low temperature alert threshold.</p>
Mix 3 High Temperature Alert	<p>The mix 3 temperature exceeded the mix 3 high temperature alert threshold. There is likely a mechanical failure with either a heat pump, boiler, valve or circulator that requires immediate attention. The control operates normally while this alert is present.</p> <p>The alert clears when the mix 3 temperature falls 2°F (1°C) below the mix 3 high temperature alert threshold.</p>
Mix 3 Low Temperature Alert	<p>The mix 3 temperature fell below the mix 3 low temperature alert threshold. There is likely a mechanical failure with either a heat pump, boiler, valve or circulator that requires immediate attention. The control operates normally while this alert is present.</p> <p>The alert clears when the mix 3 temperature rises 2°F (1°C) above the mix 3 low temperature alert threshold.</p>
Heat Pump [X] Service Hours Alert	<p>The heat pump run time has exceeded the recommended heat pump service hours alert interval. Once maintenance has been completed, the service interval can be reset in the heat pump status screen.</p>
Boiler 1 Service Hours Alert	<p>The boiler run time has exceeded the recommended boiler service hours alert interval. Once maintenance has been completed, the service interval can be reset in the boiler status screen.</p>
Heat Pump [X] Service Cycles Alert	<p>The heat pump has exceeded the recommended heat pump service cycles. Once maintenance has been completed, the service interval can be reset in the heat pump status screen.</p>
Boiler 1 Service Cycles Alert	<p>The boiler has exceeded the recommended boiler service cycles. Once maintenance has been completed, the service interval can be reset in the boiler status screen.</p>

Technical Data

SMART HEAT PUMP CONTROL 291

Literature	IOM-T-291, ES-T-291, A-T-291 Job Record 291
Packaged weight	4.1 lbs (1.87 kg)
Dimensions	9" H x 8" W x 211/16" D (229 x 203 x 60 mm)
Display	5" color touchscreen
Enclosure	Blue ABS plastic, NEMA type 1
Approvals	CSA C US, FCC Part 15B, CAN ICES-3 (B)/NMB-3(B)
Ambient conditions	Indoor use only, 32 to 122°F (0 to 50°C), < 90% RH non-condensing, Installation Category II, Pollution Degree 2
Power supply	115 V (ac) ±10%, 60 Hz, 7 W
Pump Relays	230 V (ac), 5 A, 1/3 hp
Staging Relays	230 V (ac), 5 A, 1/10 hp
Modulating Outputs	0-10 V (dc) 500 Ω minimum load impedance or 4-20 mA 1 kΩ max load impedance
Calls	24 V (ac) or Short
Sensors Included	1x Outdoor Sensor 070, 4x Universal Sensor 082
Communications	10/100 Ethernet, WiFi 802.11b/g/n, 2.4 GHz, WPA2 encryption
Mobile App	Apple* iOS 14 or higher, Android** 10 or higher
Warranty	Limited 3 Year

* Apple and App Store are trademarks of Apple Inc.

** Google, Android and Google Play are trademarks of Google LLC.

Limited Warranty and Product Return Procedure

Limited Warranty *The liability of tekmar under this warranty is limited. The Purchaser, by taking receipt of any tekmar product ("Product"), acknowledges the terms of the Limited Warranty in effect at the time of such Product sale and acknowledges that it has read and understands same. The online warranty for this product is located on Watts website (<https://www.watts.com/resources/warranty-information>) and in the event that the terms or conditions of this manual conflict with the online warranty, the terms and conditions of the online warranty shall control.*

The tekmar Limited Warranty to the Purchaser on the Products sold hereunder is a manufacturer's pass-through warranty which the Purchaser is authorized to pass through to its customers. Under the Limited Warranty, each tekmar Product is warranted against defects in workmanship and materials if the Product is installed and used in compliance with tekmar's instructions, ordinary wear and tear excepted. The pass-through warranty period is for a period of twenty-four (24) months from the production date if the Product is not installed during that period, or twelve (12) months from the documented date of installation if installed within twenty-four (24) months from the production date.

The liability of tekmar under the Limited Warranty shall be limited to, at tekmar's sole discretion either (a) the cost of parts and labor provided by tekmar to repair defects in materials and workmanship of the defective product; or (b) to the exchange of the defective product for a warranty replacement product; or (c) to the granting of credit limited to the original cost of the defective product. Such repair, exchange, or credit shall be the sole remedy available from tekmar, and, without limiting the foregoing in any way, tekmar is not responsible, in contract, tort, or strict product liability, for any other losses, costs, expenses, inconveniences, or damages, whether direct, indirect, special, secondary, incidental, punitive, or consequential, arising from ownership or use of the product, or from defects in workmanship or materials, including any liability for fundamental breach of contract.

The pass-through Limited Warranty applies only to those defective Products returned to tekmar during the warranty period. This Limited Warranty does not cover the cost of the parts or labor to remove or transport the defective Product, or to reinstall the repaired or replacement Product, all such costs and expenses being subject to Purchaser's agreement and warranty with its customers.

Any representations or warranties about the Products made by Purchaser to its customers which are different from or in excess of the tekmar Limited Warranty are the Purchaser's sole responsibility and obligation. Purchaser shall indemnify and hold tekmar harmless from and against any and all claims, liabilities and damages of any kind or nature which arise out of or are related to any such representations or warranties by Purchaser to its customers.

The pass-through Limited Warranty does not apply if the returned Product has been damaged by negligence by persons other than tekmar, accident, fire, Act of God, abuse or misuse; or has been damaged by modifications, alterations or attachments made subsequent to purchase which have not been authorized by tekmar; or if the Product was not installed in compliance with tekmar's instructions and/or the local codes and ordinances; or if due to defective installation of the Product; or if the Product was not used in compliance with tekmar's instructions.

THIS WARRANTY IS IN LIEU OF ALL OTHER WARRANTIES, EXPRESS OR IMPLIED, WHICH THE GOVERNING LAW ALLOWS PARTIES TO CONTRACTUALLY EXCLUDE, INCLUDING, WITHOUT LIMITATION, IMPLIED WARRANTIES OF MERCHANTABILITY and FITNESS FOR A PARTICULAR PURPOSE, DURABILITY OR DESCRIPTION OF THE PRODUCT, ITS NON-INFRINGEMENT OF ANY RELEVANT PATENTS OR TRADEMARKS, and ITS COMPLIANCE WITH OR NON-VIOLATION OF ANY APPLICABLE ENVIRONMENTAL, HEALTH OR SAFETY LEGISLATION; THE TERM OF ANY OTHER WARRANTY NOT HEREBY CONTRACTUALLY EXCLUDED IS LIMITED SUCH THAT IT SHALL NOT EXTEND BEYOND TWENTY-FOUR (24) MONTHS FROM THE PRODUCTION DATE, TO THE EXTENT THAT SUCH LIMITATION IS ALLOWED BY THE GOVERNING LAW.

Product Warranty Return Procedure All Products that are believed to have defects in workmanship or materials must be returned, together with a written description of the defect, to the tekmar Representative assigned to the territory in which such Product is located. If tekmar receives an inquiry from someone other than a tekmar Representative, including an inquiry from Purchaser (if not a tekmar Representative) or Purchaser's customers, regarding a potential warranty claim, tekmar's sole obligation shall be to provide the address and other contact information regarding the appropriate Representative.



A WATTS Brand

All specifications are subject to change without notice

Tel: 1-800-438-3903 • Fax: (250) 984-0815

tekmarControls.com

