

# Installation, Operation and Maintenance Manual

## Light Commercial Reverse Osmosis Systems

Models: RX-4040-01-1, RX-4040-02-1 & RX-4040-03-1



## **THANK YOU**

Congratulations on your purchase of this Watts® RX-40 light commercial reverse osmosis system. You've made an excellent choice for delivering high-quality water while reducing contaminants that can impact your equipment and water quality. This system has been designed for reliable performance and built using premium components to ensure efficiency and durability. With user-friendly operation, corrosion-resistant materials, and a service-friendly design, your system is engineered for long-term, hassle-free maintenance.

Thank You!

The Watts Team

Reverse osmosis filtration offers a wide range of benefits, including reducing dissolved solids, reducing scale buildup in critical equipment, and providing clean, quality water. By protecting your plumbing and appliances from mineral deposits and other impurities, this system helps minimize maintenance costs and downtime while ensuring consistent water quality for your commercial applications.

## ⚠ WARNING



**Please read carefully before proceeding with installation. Your failure to follow any attached instructions or operating parameters may lead to the product's failure.**

**Keep this Manual for future reference.**



## ⚠ WARNING

If you are unsure about installing your Watts reverse osmosis system contact a Watts representative or consult a professional water treatment dealer or plumber.

You are required to thoroughly read all installation instructions and product safety information before beginning the installation of this product. **FAILURE TO COMPLY WITH PROPER INSTALLATION AND MAINTENANCE INSTRUCTIONS COULD RESULT IN PRODUCT FAILURE WHICH CAN CAUSE PROPERTY DAMAGE, PERSONAL INJURY AND/OR DEATH.** Watts is not responsible for damages resulting from improper installation and/or maintenance. Local building or plumbing codes may require modifications to the information provided. You are required to consult the local building and plumbing codes prior to installation. If this information is not consistent with local building or plumbing codes, the local codes should be followed.

Save manual for future reference.

Refer to the enclosed for operating parameters to ensure proper use with your water supply.

- As with all plumbing projects, it is recommended that a trained professional water treatment dealer or contractor install the water treatment system. Please follow all local plumbing codes for installing this water treatment system.
- Inspect the water treatment system for carrier shortage or shipping damage before beginning installation. Replace any damaged component immediately, before beginning installation.
- Use caution when installing soldered metal piping near the water treatment system. Heat can adversely affect the system's components.
- Use only lead-free solder and flux for sweat-solder connections, as required by state, province and federal codes.
- Handle all components of the system with care. Do not drop, drag or turn components upside down.
- Be sure the floor under the system is clean, level and strong enough to support the system while in operation.
- Install the system in a protected area.
- Do not attempt to treat water over 100°F (38°C) or under 34°F (1°C) with the system.
- Do not install in direct sunlight as overheating of electronics may occur and ultraviolet rays from the sun may cause damage. Exterior protection equipment is required for outdoor operation. Failure to follow outdoor installation requirements will void the warranty. Please consult Watts technicians before installing the system outside.
- Operating ambient temperature: 34° to 120°F (1° to 49°C).
- Operating water pressure range : 10 to 200psi (69 kPa to 13.8 bar).

- All plumbing connections to the system should be made using industry accepted best practices. Plumbing tape or paste may be used on metal inlet and outlet plumbing connections. Do not use paste type pipe thread sealants on the system's plastic plumbing connections.
- All electrical connections must be completed according to local codes.
- The power outlet must be grounded.
- For installations where plastic plumbing is used, install an appropriate grounding strap across the inlet and outlet piping of the building's metal plumbing to ensure that a proper ground is maintained.
- Always turn off the unit, shut off the feed water, and disconnect the electrical power when working on the unit.
- Observe drain line requirements.
- Support the full weight of the plumbing system with pipe hangers or other means.
- Do not allow this water treatment system to freeze. Damage from freezing will void this water treatment system's warranty.
- Periodic cleaning and maintenance is required for system to function properly.
- Observe all warnings that appear in this manual.

## How To Use This Manual

This installation manual is designed to guide the installer through the process of installing and starting up this commercial reverse osmosis system.

This manual is a reference and will not include every system installation situation. The person installing this equipment should have:

- Training on the control panel with all control parameters.
- Knowledge of reverse osmosis systems and how to determine proper control settings.
- Adequate plumbing skills.

## ⚠ WARNING

**Do not use with water that is microbiologically unsafe or of unknown quality without adequate disinfection before or after the system.**

# Contents

How To Use This Manual .....	3
I. Introduction .....	4
A. Reverse Osmosis Overview .....	4
B. Specifications .....	5
C. Operating Limits .....	5
D. Pretreatment .....	5
II. Controls, Indicators, and Components .....	6
III. Operation .....	6
A. Installation .....	6
B. Plumbing Connections .....	6
C. Electrical .....	7
D. Startup .....	7
E. Flushing the System .....	7
F. Preparing Unit for Storage .....	7
IV. Controller Specifications and Instructions .....	8
A. Controller Specifications .....	8
B. Simplified Schematics .....	9
C. Controller Overview .....	10
D. RX-40 Flow Diagram .....	11
E. Operation and Maintenance Log .....	12
F. Troubleshooting .....	13
V. Replacement Parts List .....	14
VI. Membrane Element Specifications .....	15
VI. Membrane Installation and Replacement .....	16
VII. Appendix .....	17
Temperature Correction Factors .....	17

# I. Introduction

The separation of dissolved solids and water using RO membranes is a pressure driven temperature dependent process. The membrane material is designed to be as permeable to water as possible, while maintaining the ability to reduce dissolved solids.

The main system design parameters require the following:

- Internal flows across the membrane surface must be high enough to prevent the accumulation of fine suspended solids, fouling, and scaling, which could reduce membrane efficiency and damage the membrane.
- The concentration of each dissolved ionic species must not exceed the limits of solubility anywhere in the system.
- Pre-treatment must be sufficient to eliminate chemicals that would attack the membrane materials, particulates, organics, and chemicals that could attack or degrade the membrane material.

## A. Reverse Osmosis Overview

Reverse osmosis systems utilize semipermeable membrane elements to separate the feed water into two streams. The pressurized feed water is separated into permeate (product) water and concentrate (reject) water. The impurities contained in the feed water are carried to the drain by the reject water. It is critical to maintain adequate reject flow in order to prevent membrane scaling and/or fouling.

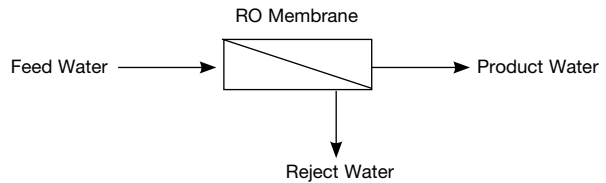

### NOTICE

Changes in operating variables are beyond the control of Watts. The end user is responsible for the safe operation of this equipment. The suitability of the product water for any specific application is the responsibility of the end user.

Successful long-term performance of an RO system depends on proper operation and maintenance of the system. This includes the initial system startup and operational startups and shutdowns. Prevention of fouling or scaling of the membranes is not only a matter of system design, but also a matter of proper operation. Record keeping and data normalization are required in order to know the actual system performance and to enable corrective measures when necessary. Complete and accurate records are also required in case of a system performance warranty claim.

Changes in the operating parameters of an RO system can be caused by changes in the feed water or can be a sign of trouble. Maintaining an operation and maintenance log is crucial in diagnosing and preventing system problems. For your reference, a typical log sheet is included in this manual

## B. Specifications

Call customer service if you need assistance with technical details.

	RX-4040-01-1	RX-4040-02-1	RX-4040-03-1
Order code	68111204	68111205	68111206
Maximum Productivity (gallons per day)	2500	5000	7500
Quality (average membrane rejection)	98% (min. 96%)		
Recovery (user adjustable)	up to 75%		
Membrane Size	4" x 40"		
Number Of Membranes	1	2	3
Prefilter (system ships with one 5 micron cartridge)	20"		
Feed Water Connection	¾" NPTF		
Product Water Connection (tubing ID)	⅝"		
Reject Water Connection (tubing ID)	⅝"		
Permeate Water (maximum)	1.74 gpm	3.47 gpm	5.21 gpm
Minimum Concentrate Flow	3 gpm		
Feed Water Pressure (minimum)	10 psi		
Electrical Requirement	230V 12 amps		230V 15 amps
Motor Horse Power	1		1½
Dimensions W x D x H (approximate inches)	20 x 22 x 56		20 X 26 X 56
Shipping Weight (estimated pounds)	120	150	180

### NOTICE

- Maximum production based on a feed water of 77°F, SDI < 1, 1000 ppm TDS, and pH 7. Individual membrane productivity may vary (± 15%). May be operated on other feed waters with reduced capacity.
- Percent rejection is based on membrane manufacturer's specifications; overall system percent rejection may be less.

## C. Operating Limits

PARAMETER	MAX	MIN
Design Temperature	77°F	
Feed Water Temperature†	85°F	40°F
Ambient Temperature	120°F	40°F†
Feed Pressure	85 psi	10 psi
Operating Pressure††	200 psi	150 psi
Turbidity	1 NTU	
SDI Rating	<3	
Free Chlorine	0 ppm	
TDS†	2,000 ppm	
Hardness	0 gpg	
pH (continuous)	10	4
pH (cleaning 30 minutes)	12	2

† Low temperatures and feedwater quality, such as high TDS levels will significantly affect the systems production capabilities and performance. Computer projections must be run for individual applications which do not meet or exceed minimum and maximum operating limits for such conditions.

†† System Operating Pressure is based on 60 psi feed pressure, minimum concentrate flow as stated and an average of 2000 gpd flow per membrane at 77°F.

\*If any of the feed water parameters are not within the limits given, consult your local dealer or distributor for assistance.

### ⚠ CAUTION

**Higher TDS and/or lower temperatures will reduce the system's production.**

### ⚠ WARNING

**Do not exceed the maximum operating pressure.**

## D. Pretreatment

The RO feed water must be pretreated in order to prevent membrane damage and/or fouling. Proper pretreatment is essential for reliable operation of any RO system.

Pretreatment requirements vary depending on the nature of the feed water. Pretreatment equipment is sold separately. The most common forms of pretreatment are described below.

**Media Filter** - Used to reduce large suspended solids (sediment) from the feed water. Backwashing the media removes the trapped particles. Backwash can be initiated by time or differential pressure. A backwash interlock is necessary to ensure proper system operation and prevent disruptions.

**Water Softener** - Used to remove calcium and magnesium from the feed water in order to prevent hardness scaling. The potential for hardness scaling is predicted by the Langelier Saturation Index (LSI). The LSI should be zero or negative throughout the unit unless approved antiscalants are used. Softening is the preferred method of controlling hardness scale. Under certain condition, softener can be eliminated with proper antiscalant dosing. Consult a Watts technician for accurate sizing and dosage projection.

**Carbon Filter** - Used to reduce chlorine and organics from the feed water. Free chlorine will cause rapid irreversible damage to the membranes. Organics (TOC) can lead to fouling, reducing system efficiency and membrane lifespan.

**The residual free chlorine present in most municipal water supplies will damage the thin film composite structure of the membranes used in this unit. Carbon filtration or sodium bisulfite injection should be used to completely remove the free chlorine residual.**

**Chemical Injection** - Typically used to feed antiscalant, coagulant, or bisulfite into the feed water or to adjust the feed water pH.

**Prefilter Cartridge** - Used to trap smaller suspended solids and any particles that may be generated by the other pretreatment. The cartridge(s) should be replaced when the pressure drop across the housing increases 5 - 10 psig over the clean cartridge pressure drop. The effect of suspended solids is measured by the silt density index (SDI) test. An SDI of five (5) or less is specified by most membrane manufacturers and three (3) or less is recommended.

**Iron & Manganese** - These foulants should be removed. Special media filters and/or chemical treatment is commonly used.

**pH** - The pH is often lowered to reduce the scaling potential. If the feed water has zero hardness, the pH can be raised to eliminate CO<sub>2</sub>.

**Silica:** Reported on the analysis as SiO<sub>2</sub>. Silica forms a coating on membrane surfaces when the concentration exceeds its solubility. Additionally, the solubility is highly pH and temperature dependent. Silica fouling can be prevented with chemical injection and/or reduction in recovery.

## II. Controls, Indicators, and Components

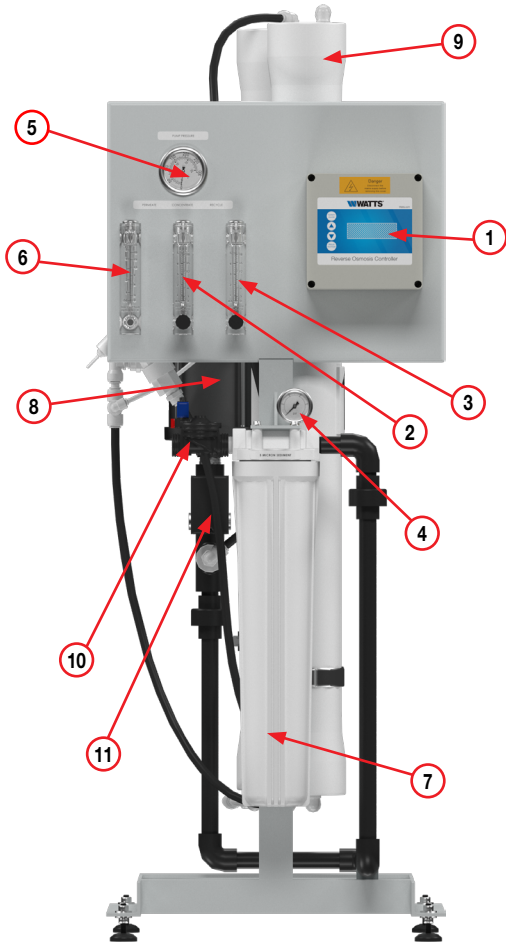

Figure 1

## III. Operation

### A. Installation

1. Proper pretreatment must be determined and installed prior to the RO system.
2. The water supply and pretreatment equipment should be sufficient to provide a minimum of 10-psig at the maximum feed flow.
3. An electrical disconnect switch located within 10 feet of the unit is recommended.
4. Responsibility for meeting local electrical and plumbing codes lies with the owner / operator.
5. Install indoors in an area protected from freezing and direct sunlight. Space allowances for the removal of the membranes from the pressure vessels should be provided.
6. Verify that a prefilter cartridge is installed in the housing. (See Figure #1, Item 7).

### B. Plumbing Connections

**Note: It is the responsibility of the end user to ensure that the installation is done according to local codes and regulations.**

1. Connect the pretreated feed water line to the prefilter inlet (Figure # 1 Item 10).
2. Temporarily connect the product water outlet to a drain. The product outlet is located behind the panel at the top of the product flow meter. The product water line should never be restricted. Membrane and/or system damage may occur if the product line is blocked. An inline check valve is located at the product line to prevent the backflow.
3. Connect the reject water outlet to a drain. The reject outlet is located behind the panel at the top of the reject flow meter. The reject drain line should never be restricted. Membrane and/or system damage may occur if the reject drain line is blocked. An air gap must be located between the end of the drain line and the drain. The use of a standpipe or other open drain satisfies most state and local codes and allows for visual inspection and sampling.

ITEM NO.	PART NAME	DESCRIPTION
1	RO controller	RO on/off control with backlit display. Standard features include pressure switch control, monitor contactor, TDS/Conductivity monitor with programmable setpoints, pre-treatment lockout, tank level switch control etc.
2	Reject Control Valve with Flow Indicator	Controls the amount of reject flow
3	Reject Recycle Control Valve with Flow Indicator	Controls the amount of recycle flow
4	Prefilter Outlet Pressure Gauge	Indicate the outlet pressures of the prefilter
5	Pump Discharge Pressure Gauge	Indicates the membrane feed pressure
6	Product Flow Meter	Indicates the product flow rate in gallons per minute (gpm)
7	Prefilter Housing	Contains the RO prefilter
8	RO Feed Pump	Pressurizes the RO feed water
9	RO Membrane Housing(s)	Contains the RO membrane(s)
10	Feed Water Inlet Isolation Valve	Connect to the water source, allow pre-treatment interlock control
11	Low Pressure Switch	Protect the feed pump from low pressure condition

## C. Electrical

Watts RX-40 series systems come pre-wired, ready to plug and play. RX-40 Series systems are available in 110/220V/60HZ/1PH. (Only RX-4040-03-1 unit is 220V) Each unit is equipped with an 8 foot electrical cord.

It is best that the RX-40 Series system be wired to a dedicated electrical circuit. Ensure that the electrical circuit supplying the system is compatible with the requirements of the specific RX-40 Series model you are installing.

For systems equipped with a chemical feed system, a chemical injection electrical plug is provided. The outlet allows the equipment to be plugged in for coordinated control. Please do not use the plug for anything other than its intended purpose.

A float switch can be installed for additional control. The liquid level switch turns the system on when the water level in the tank drops, and off when the tank is full. Liquid level switches can be obtained by your local dealer or distributor. If a liquid level switch is to be used, install it at this time. To install a normally closed float switch, locate the high pressure switch and remove the red wire from terminal 2 and relocate it to terminal 4. Cut the float switch pigtails and strip back ½" of each of the wire insulations. Install the float switch leads to terminals 2 and 3. See electrical diagram below.

### ⚠ WARNING

**To reduce the risk of electrical shock, the incoming power supply must include a protective earth ground.**

**It is recommended that a licensed electrician wire your system in accordance with local and national electrical codes (NEC).**

Remove red wire from terminal 2 and connect to terminal 4

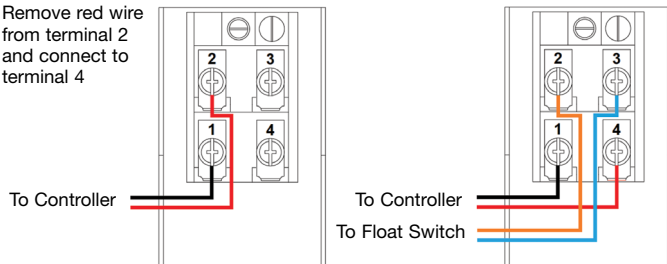

## D. Startup

1. Verify that the pretreatment equipment is installed and working properly. Verify that no free chlorine is present in the feed water.
2. Verify that the on / off switch is in the off position.
3. Verify that a filter cartridge is installed in the prefilter housing
4. Direct the permeate water to drain during startup.
5. Open the reject control valve completely (Figure # 1 item 2).
6. Close the reject recycle control valve (Figure # 1 item 3) completely.
7. Open the feed water shutoff valve (Figure # 1 item 10).
8. Turn the system on by pressing the on/off button from the controller.
9. Allow the unit to run for 15 – 30 minutes to flush the preservative from the membrane(s).
10. Adjust the reject control valves (Figure # 1 items 2 and 3) until the desired flows are achieved. Closing the reject valve increases the product flow and decreases the reject flow. Opening the reject recycle valve decreases both the reject and product flow. See the flow rate guidelines and temperature correction table in the appendix to determine the flow rates for different operating temperatures.
11. Allow the product water to flow to drain for 30 minutes.
12. Turn off the system and connect the product water line to the point of use. The product water line should never be restricted. Membrane and/or system damage may occur if the product water line is blocked.
13. Restart the system and record the initial operating data using the log sheet.

## E. Flushing the System

As time progresses, the efficiency of the membrane will be reduced. In general, the salt rejection does not change significantly until two or three years after installation when operated on properly pretreated feed water. The permeate flow rate will begin to decline slightly after one year of operation, but can be extended with diligent flushing and cleaning of the membranes. The system should be flushed regularly to remove sediment from the surface of the membranes. RX-40 series systems are preprogrammed to flush for 60 seconds on shut down, 2 minutes for permeate flush and 5 minutes for manual flush.

## F. Preparing Unit for Storage

If the system is to be shut down for an extended period, a membrane preservative should be used to preserve the membranes.

### NOTICE

Prior to storing your system, the system should be cleaned with membrane cleaners, flushed with permeate water and preservative solution for membranes to protect it from biological attack.

### NOTICE

The pressure vessels and plumbing lines of the system must be completely drained or filled with 20-40% polyglycol mix (to prevent freezing). Any water remaining in the plumbing of a system may freeze, causing serious damage.

1. Completely immerse the elements in the membrane housings using 2% preservative solution. For cold weather/winter storage add 20 - 40% by weight Polyglycol to the 2% preservative solution. Add Polyglycol AFTER the 2% preservative solution has been mixed.
2. Separate the preservative solution from the air outside by closing all valves. Any contact with oxygen will oxidize the preservative solution.
3. Check the pH once a week. When the pH becomes 3 or lower, change the preservation solution.
4. Repeat this process at least once a month.

## IV. Controller Specifications and Instructions

### A. Controller Specifications

INPUTS	
Tank Level Switches	(2) Normally-Closed. Preprogrammed with a single level switch prewired to a High Pressure switch. The Tank, Low Pressure and Pretreat inputs are 50% duty cycle square wave, 10VDC peak @ 10mA max. The switch inputs are dry contacts only. Applying voltage to these terminals will damage the controller.
Inlet Pressure Switch	Normally-Open.
Pretreat Lockout Switch	Normally-Closed.
Controller Power	110-120/208-240 VAC, 60/50Hz (Range: 110-240 VAC)
Permeate Conductivity	0-3000 PPM, 0-6000 $\mu$ s (standard sensor, CP-1, K=.75)
OUTPUT CIRCUIT RATINGS	
Feed Solenoid	1A. Voltage is the same as motor/supply voltage.
Flush Solenoid	1A. Voltage is the same as motor/supply voltage.
Motor	1.0 HP/110-120V, 2.0 HP/208-240V.
CIRCUIT PROTECTION	
Relay Fuse	F1, 5x20mm, 2 Amp, Belfuse 5ST 2-R Note: The fuse shown above is for supplemental protection only. Branch circuit protection and disconnect means must be provided externally. See Field Wiring Diagram for Branch Circuit protection requirements.
OTHER	
Dimensions	7" tall, 7" wide, 4" deep. Nema 4X* Polycarbonate Hinged Enclosure.
Weight	2.6 lb. (Basic Configuration).
Environment	0-50°C, 10-90%RH (non-condensing). *Note: After our modification the enclosure rating is Nema 1.

## B. Simplified Schematics

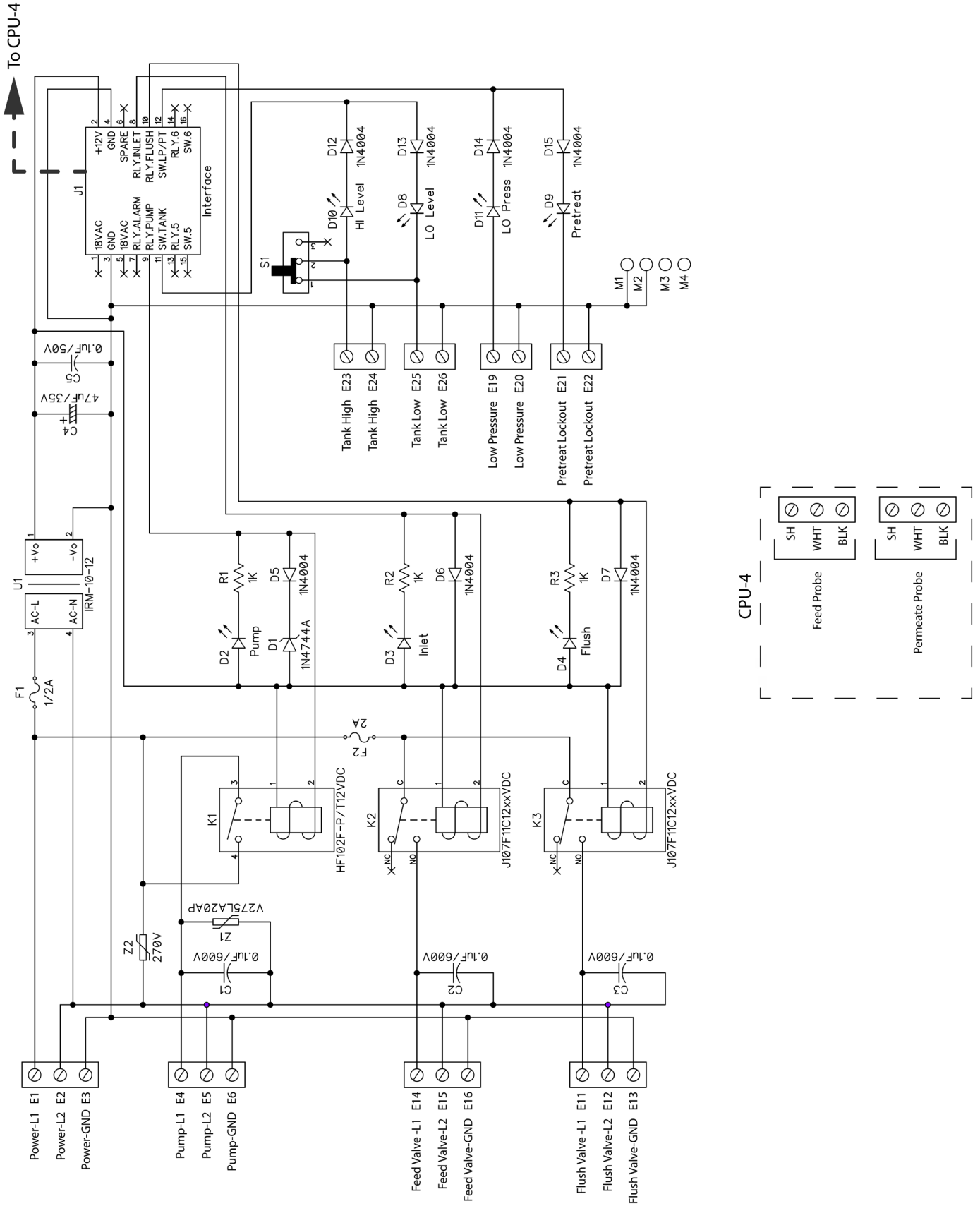

# C. Controller Overview

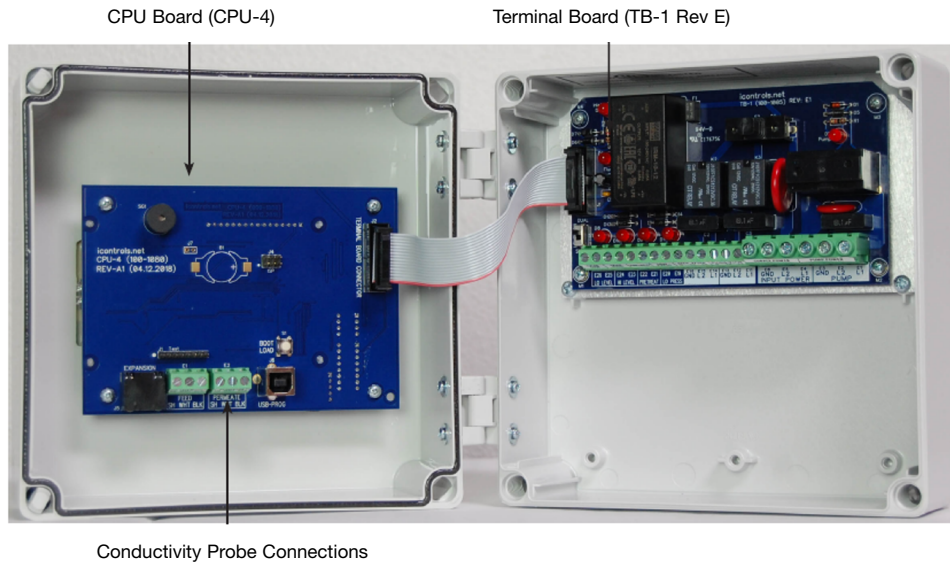
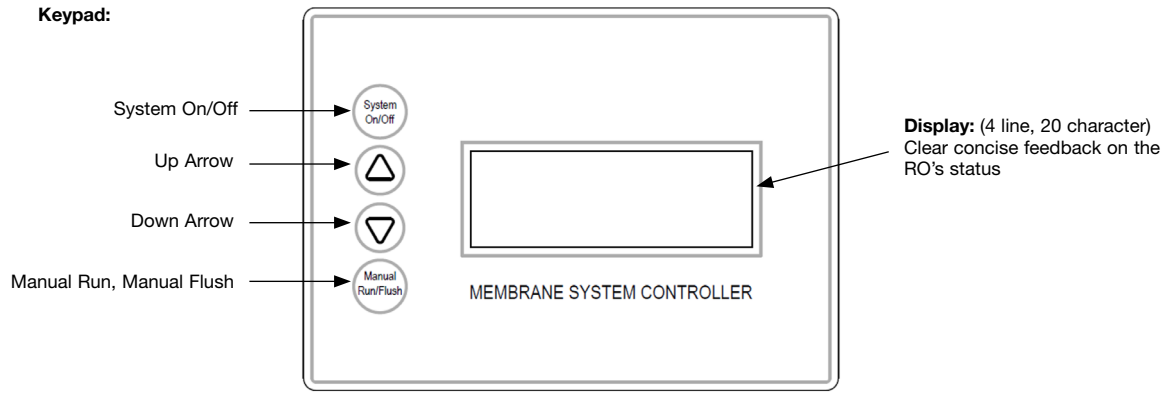

# D. RX-40 Flow Diagram

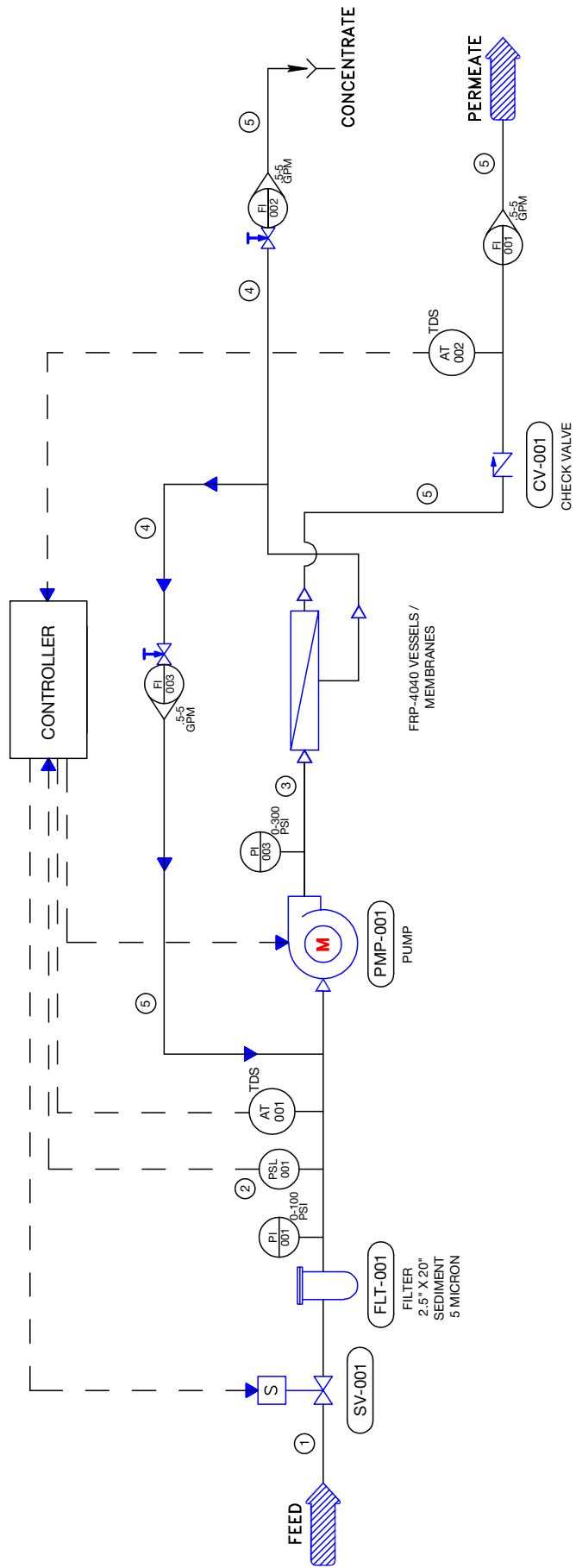



## F. Troubleshooting

### RO Membrane Troubleshooting Guide

SYMPTOMS			LOCATION	POSSIBLE CAUSES	VERIFICATION	CORRECTIVE ACTION
SALT PASSAGE	PERMEATE FLOW	PRESSURE DROP				
Normal to increased	Decreased	Normal to increased	Predominantly first stage	Metal oxide	Analysis of metal ions in cleaning solution.	Improved pretreatment to remove metals. Cleaning with acid cleaners.
Normal to increased	Decreased	Normal to increased	Predominantly first stage	Colloidal fouling	SDI measurement of feed/ X-ray diffraction analysis of cleaning sol. residue.	Optimize pretreatment system for colloid removal. Clean with high pH, anionic detergent formulation.
Increased	Decreased	Increased	Predominantly last stage	Scaling (CaSO <sub>4</sub> , CaSO <sub>3</sub> , BaSO <sub>4</sub> , SiO <sub>2</sub> )	Analysis of metal ions in cleaning sol. Check LSI of reject. Calculate maximum solubility for CaSO <sub>4</sub> , BaSO <sub>4</sub> , SiO <sub>2</sub> in reject analysis.	Increase acid addition and scale inhibitor for CaSO <sub>3</sub> and CaSO <sub>4</sub> . Reduce recovery. Clean with an acid formulation for CaCO <sub>3</sub> , CaSO <sub>4</sub> and BaSO <sub>4</sub> .
Normal to moderate increase	Decreased	Normal to moderate increase	Can occur in any stage	Biological fouling	Bacteria count in permeate and reject. Slime in pipes and vessels.	Shock dosage of sodium bisulfite. Continuous feed of low conc. bisulfite at reduced pH. Peracetic acid cleaning. Clean with alkaline anionic surfactant. Chlorine dosage upstream with dechlorination. Replace cartridge filters.
Decreased or moderately increased	Decreased	Normal	All stages	Organic fouling	Destructive testing, e.g. IR reflection analysis.	Optimization of pretreatment system (e.g. coagulation process.) Resin/ activated carbon treatment. Clean with high pH detergent.
Increased	Increased	Decreased	Most severe in the first stage	Chlorine oxidant attack	Chlorine analysis of feed. Destructive element test.	Check chlorine feed equipment and dechlorination equipment.
Increased	Increased	Decreased	Most severe in the first stage	Abrasion of membrane by crystalline material	Microscopic solids analysis of feed. Destructive element test.	Improved pretreatment. Check all filters for media leakage.
Increased	Normal to increased	Decreased	At random	O-ring leaks, End or side seal glue leaks.	Probe test. Vacuum test. Colloidal material passage.	Replace O-rings. Repair or replace elements.
Increased	Normal to low	Decreased	All stages	Conversion too high.	Check flows and pressures against design guidelines	Reduce conversion rate. Calibrate sensors. Increase analysis and data collection.

## RO System Troubleshooting

SYMPTOMS	POSSIBLE CAUSES	CORRECTIVE ACTION
Low Inlet Pressure	Low supply pressure	Increase inlet pressure
	Cartridge filters plugged	Change filters
	Solenoid valve malfunction	Replace solenoid valve and/or coil
	Leaks	Fix any visible leaks
Low Permeate Flow	Low inlet flow	Adjust concentrate valve
	Cold feedwater	See temperature correction sheet
	Low operating pressure	See low inlet pressure
	Defective membrane brine seal	Inspect and/or replace brine seal
	Fouled or scaled membrane	Clean membranes
High Permeate Flow	Damaged product tube o-rings	Inspect and/or replace
	Damaged or oxidized membrane	Replace membrane
	Exceeding maximum feedwater temperature	See temperature correction sheet
Poor Permeate Quality	Low operating pressure	See low inlet pressure
	Damage product tube o-rings	Inspect and/or replace
	Damaged or oxidized membrane	Replace membrane
Membrane Fouling	Metal oxide fouling	Improve pretreatment to remove metals. Clean with acid cleaners
	Colloidal fouling	Optimize pretreatment for colloid removal. Clean with high pH anionic cleaners
	Scaling (CaSO <sub>4</sub> , CaSO <sub>3</sub> , BaSO <sub>4</sub> , SiO <sub>2</sub> )	Increase acid addition and antiscalant dosage for CaCO <sub>3</sub> and CaCO <sub>4</sub> . Reduce recovery. Clean with acid cleaners
	Biological fouling	Shock dosage of sodium bi-sulfate. Continuous feed of sodium bi-sulfate at reduced pH. Chlorination and de-chlorination. Replace cartridge filters.
	Organic fouling	Activated carbon or another pretreatment. Clean with high pH cleaner
	Abrasion of membrane by crystalline material	Improve pretreatment. Check all filters for media leakage

## V. Replacement Parts List

A list of common replacement parts is provided below. Contact your Watts representative for replacement parts assistance.

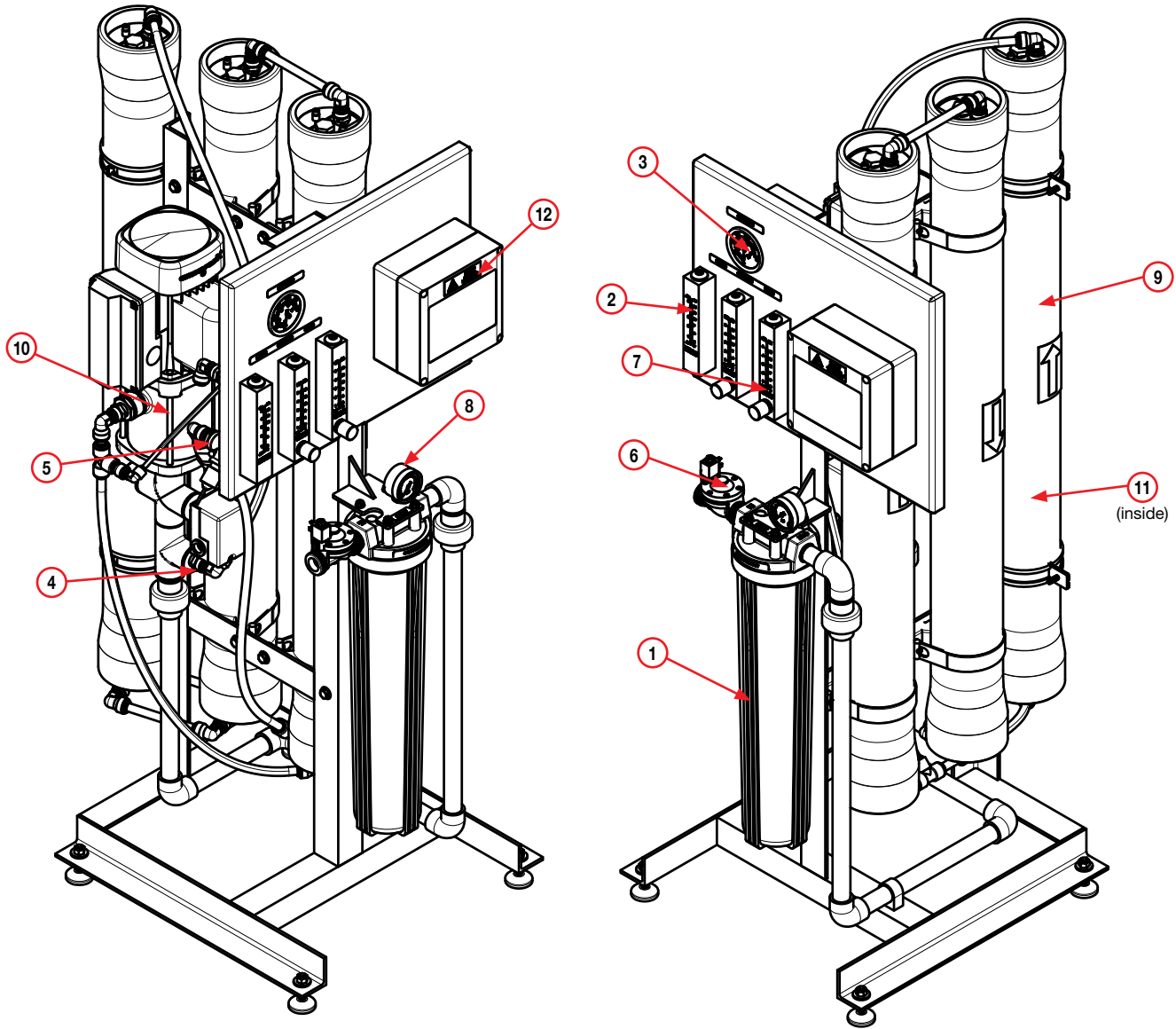

ITEM NO.	ORDER CODE	DESCRIPTION
1	5000000094	CARTRIDGE, SEDIMENT, POLYPRO, 2.5" X 20", 5 MIC
2	5000000095	METER, FLOW, PM, 1-5 GPM, 1/2" MNPT x 1/4" FNPT
3	5000000096	GAUGE, BKM, FILL, 0-300 PSI/BAR, 2.5" DIA, 1/4" MNPT
4	5000000097	SWITCH, PRESSURE, LOW, 1/4" FNPT
5	5000000098	VALVE, CHECK, PVC, 1/2" FNPT X 1/2" FNPT
6	5000000099	VALVE, SOLENOID, N/C, UL, 220V, 3/4" FNPT, 3 METER CORD, GC
6	5000000140	VALVE, SOLENOID, NC, UL, 110V, 3/4" FNPT, NO DIN, GC
7	5000000100	METER, FLOW, PM, 0.5-5 GPM, SS VALVE, 1/2" MNPT X 1/2" MNPT
8	5000000101	GAUGE, BTM, NO FILL, 0-100 PSI/BAR, 2" DIA, 1/4" MNPT
9	5000000102	HOUSING, MEMBRANE, FRP-300E, 4040, 1/2" P X 1/2" C FNPT
10	5000000103	PUMP, CM1-6, 1HP, 115/230V 60HZ 1PH, 304SS, 98125766, GRUNDFOS
10	5000000104	PUMP, CM1-7, 1.5HP, 115/230V 60HZ 1PH, 304SS, 99041161, GRUNDFOS
11	68112306	MEMBRANE, WMS, 4040, DRY, WATTS
12	5000000105	CONTROLLER, COMPUTER, 110/220V, 1PH, WATTS OVERLAY

## VI. Membrane Element Specifications

RX-40 Series reverse osmosis systems come standard with WM5--4040-ULE Low Energy membranes. General membrane element performance characteristics are listed on the following membrane specification chart.

### WM5-4040-ULE Ultra Low Energy Membranes (Standard)

**Membrane Type:** Polyamide Thin – Film Composite

Maximum Operating Temperature: 113°F (45°C)

Maximum Operating Pressure: 600 psi (4.14 MPa)

pH Range, Continuous Operation\*: 2 – 11

pH Range, Short Term Cleaning (30 Min.): 2 – 11

Maximum Feed Silt Density Index (SDI): 5

Chlorine Tolerance: 0 ppm

Maximum Feed Flow Rate (gpm): 15

\*Maximum temperature for continuous operations above pH 10 is 95 °F (35 °C).

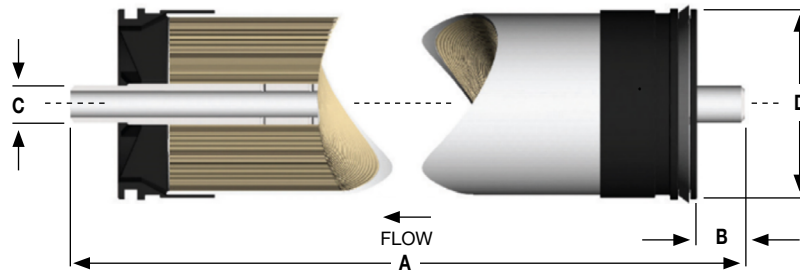

PRODUCT SPECIFICATIONS				DIMENSION INCH / MM			
PART NUMBER	DESCRIPTION	APPLIED PRESSURE PSI / BAR	PERMEATE FLOW RATE GPD / LPD	A	B	C	D
68112306	WM5-4040-ULE	100 / 6.9	3500 / 13249	40 / 1016.00	1.04 / 26.50	0.75 / 19.05	3.90 / 99.20

Warranty Evaluation Test Conditions: Permeate flow and salt rejection based on the following test conditions – 550 ppm, filtered and dechlorinated municipal tap water, 77°F / 25°C, 15% recovery and the specified operating pressure. Minimum salt rejection is 96%. Permeate flows for warranty evaluation may vary +/-20%. Maximum pressure drop at 15 psig / 0.9 bar.

All 4040 elements fit nominal 4.00" I.D. membrane housings.

Proper start-up of reverse osmosis water treatment systems is essential to prepare the membranes for operating service and to prevent membrane damage due to overfeeding or hydraulic shock. Before initiating system start-up procedures, membrane pretreatment, loading of the membrane elements, instrument calibration and other system checks should be completed.

Avoid any abrupt pressure or crossflow variations on the spiral elements during start-up, shutdown, cleaning or other sequences to prevent possible membrane damage. During start-up, a gradual change from a standstill to operating state is recommended as follows:

- Feed pressure should be increased gradually over a 30 – 60 second time frame.
- Cross – flow velocity at set operating point should be achieved gradually over 15 – 20 seconds.
- Permeate obtained from first hour of operation should be discarded.
- Maximum pressure drop across an entire single membrane pressure vessel (housing) can be up to 15 psi / 1.03 bar.
- Avoid static permeate – side backpressure at all times.

Under certain conditions, the presence of free chlorine, chloramines and other oxidizing agents will cause premature membrane failure. Since oxidation damage is not covered under warranty, the manufacturer recommends removing all oxidizing agents by pretreatment prior to membrane exposure. Please contact the manufacturer or your supplier for more information.

Do not use this initial permeate for drinking water or food preparation. Keep elements moist at all times after initial wetting. To prevent fouling during prolonged system shutdowns, it is recommended that membrane elements be immersed in a preservative solution. Rinse out the preservative before use. For membrane warranty details, please contact the manufacturer or your supplier for more information.

If operating limits and guidelines given in this product specification sheet are not strictly followed, the warranty will be null and void. The customer is fully responsible for the effects of incompatible chemicals and lubricants on elements. Use of any such chemicals or lubricants will void the warranty. These membranes may be subject to drinking water application restrictions in some countries; please check the application status before use and sale. The use of this product in and of itself does not necessarily guarantee the removal of cysts and pathogens from water.

No freedom from infringement of any patent owned by the manufacturer or others is to be inferred. Because use conditions and applicable laws may differ from one location to another and may change with time, customer is responsible for determining whether products and the information in this document are appropriate for customer's use and for ensuring that customer's workplace and disposal practices are in compliance with applicable laws and other governmental enactments. The claims made may not have been approved for use in all countries. The manufacturer assumes no obligation or liability for the information in this document. **NO WARRANTIES ARE GIVEN; ALL IMPLIED WARRANTIES OF MERCHANTABILITY OR FITNESS FOR A PARTICULAR PURPOSE ARE EXPRESSLY EXCLUDED.**

# VI. Membrane Installation and Replacement

1. Turn off the system and close the feed water shutoff valve.
2. Unplug the unit.
3. Disconnect the tubing from the top of the membrane housing(s).



**All pressure gauges must read zero before beginning this procedure. Turn the system off, disconnect the power, and bleed all water pressure from the system.**

## CAUTION

**The brine seal must be in the correct position for each membrane housing in order for the membrane to function correctly.**

Pay close attention to the flow direction arrows on the membrane housings when installing new membranes. Refer to the following chart:

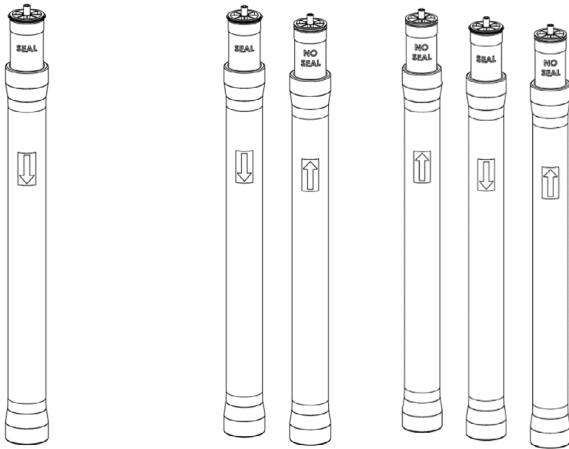

RX-4040-01-1

RX-4040-02-1

RX-4040-03-1

## NOTICE

Wear gloves for the following steps in order not to contaminate the membrane.

4. Unscrew and remove the two locking crescents using a #5 Hex wrench. Use a 1/2" x 6" PVC nipple (or similar material) and thread it into the end plug permeate port to hand tightness. Pull the pipe outward to remove the end plug. If the pressure vessel has been in operation for an extended time, a slight rocking motion or forceful tug may be required. Set the end plug aside in a clean area where the O-ring will not pick up dirt or debris.



5. Remove the membrane bag containing the membrane element from the shipping box.
6. Cut the bag open as close as possible to the seal at the end of the bag, so the bag may be re-used if necessary.
7. Make sure that all parts are clean and free from dirt. Examine the brine seal and permeate tube for nicks or cuts. Replace the O-rings or brine seal if damaged.
8. Remove the old membranes from the pressure vessels. Use long nose pliers to pull the old membrane out of the pressure vessel.
9. Lubricate the brine seal and O-rings on the new membranes with a non-petroleum based lubricant. Do not use a petroleum-based lubricant.
10. Apply the same lubricant to the inside of the pressure vessel below the groove for the locking crescents, where the membrane brine seal will make contact when inserted.
11. Install membranes with brine seal location depicted in the membrane flow chart on the previous page.
12. When loading a membrane brine seal first, insert the membrane at a slight angle while gently rotating, being careful not to tear or flip the brine seal. With a smooth and constant motion, carefully push the membrane into the pressure vessel. A slow twisting motion should be used while inserting the membrane to ensure the brine seal stays in place. If there is considerable resistance when attempting to insert the membrane remove it and re-lube the brine seal and pressure vessel entrance as necessary. Pushing the membrane into the pressure vessel forcefully will cause the brine seal to flip at which point the membrane will no longer operate properly.
13. The membrane should stop when fully seated on the bottom end plug.
14. Reassemble the top end plugs.

## NOTICE

Make sure the O-rings and end plugs are free from dirt and debris before re-installing. Dirt and other foreign materials left on the end plugs can cause leaks and/or damage the membranes and cause contamination.

15. Re-install the end plugs by gently and evenly pushing them onto the pressure vessel. Ensure that you do not pinch or fatigue any O-rings while re-installing the end plug. Push the end plug in until it is seated just below the groove for the locking crescents.
16. Reinstall the locking crescents and securely tighten the screws.
17. Reconnect any fittings that may have been disconnected when the pressure vessels were disassembled.
18. To start-up the system, please refer to the Start-Up section of this User's Manual.

## NOTICE

The membranes must be flushed for at least 1 hour to remove the preservative from the membrane. Discard all of the permeate produced during the flush period.

# VII. Appendix

## Temperature Correction Factors

TEMPERATURE °F (°C)	TEMPERATURE CORRECTION FACTOR	TEMPERATURE °F (°C)	TEMPERATURE CORRECTION FACTOR	TEMPERATURE °F (°C)	TEMPERATURE CORRECTION FACTOR	TEMPERATURE °F (°C)	TEMPERATURE CORRECTION FACTOR	TEMPERATURE °F (°C)	TEMPERATURE CORRECTION FACTOR
50.0 (10.0)	1.711	57.2 (14.0)	1.475	64.4 (18.0)	1.276	71.6 (22.0)	1.109	78.8 (26.0)	0.971
50.2 (10.1)	1.705	57.4 (14.1)	1.469	64.6 (18.1)	1.272	71.8 (22.1)	1.105	79.0 (26.1)	0.968
50.4 (10.2)	1.698	57.6 (14.2)	1.464	64.8 (18.2)	1.267	72.0 (22.2)	1.101	79.2 (26.2)	0.965
50.5 (10.3)	1.692	57.7 (14.3)	1.459	64.9 (18.3)	1.262	72.1 (22.3)	1.097	79.3 (26.3)	0.962
50.7 (10.4)	1.686	57.9 (14.4)	1.453	65.1 (18.4)	1.258	72.3 (22.4)	1.093	79.5 (26.4)	0.959
50.9 (10.5)	1.679	58.1 (14.5)	1.448	65.3 (18.5)	1.254	72.5 (22.5)	1.090	79.7 (26.5)	0.957
51.1 (10.6)	1.673	58.3 (14.6)	1.443	65.5 (18.6)	1.249	72.7 (22.6)	1.086	79.9 (26.6)	0.954
51.3 (10.7)	1.667	58.5 (14.7)	1.437	65.7 (18.7)	1.245	72.9 (22.7)	1.082	80.1 (26.7)	0.951
51.4 (10.8)	1.660	58.6 (14.8)	1.432	65.8 (18.8)	1.240	73.0 (22.8)	1.078	80.2 (26.8)	0.948
51.6 (10.9)	1.654	58.8 (14.9)	1.427	66.0 (18.9)	1.236	73.2 (22.9)	1.075	80.4 (26.9)	0.945
51.8 (11.0)	1.648	59.0 (15.0)	1.422	66.2 (19.0)	1.232	73.4 (23.0)	1.071	80.6 (27.0)	0.943
52.0 (11.1)	1.642	59.2 (15.1)	1.417	66.4 (19.1)	1.227	73.6 (23.1)	1.067	80.8 (27.1)	0.940
52.2 (11.2)	1.636	59.4 (15.2)	1.411	66.6 (19.2)	1.223	73.8 (23.2)	1.064	81.0 (27.2)	0.937
52.3 (11.3)	1.630	59.5 (15.3)	1.406	66.7 (19.3)	1.219	73.9 (23.3)	1.060	81.1 (27.3)	0.934
52.5 (11.4)	1.624	59.7 (15.4)	1.401	66.9 (19.4)	1.214	74.1 (23.4)	1.056	81.3 (27.4)	0.932
52.7 (11.5)	1.618	59.9 (15.5)	1.396	67.1 (19.5)	1.210	74.3 (23.5)	1.053	81.5 (27.5)	0.929
52.9 (11.6)	1.611	60.1 (15.6)	1.391	67.3 (19.6)	1.206	74.5 (23.6)	1.049	81.7 (27.6)	0.926
53.1 (11.7)	1.605	60.3 (15.7)	1.386	67.5 (19.7)	1.201	74.7 (23.7)	1.045	81.9 (27.7)	0.924
53.2 (11.8)	1.600	60.4 (15.8)	1.381	67.6 (19.8)	1.197	74.8 (23.8)	1.042	82.0 (27.8)	0.921
53.4 (11.9)	1.594	60.6 (15.9)	1.376	67.8 (19.9)	1.193	75.0 (23.9)	1.038	82.2 (27.9)	0.918
53.6 (12.0)	1.588	60.8 (16.0)	1.371	68.0 (20.0)	1.189	75.2 (24.0)	1.035	82.4 (28.0)	0.915
53.8 (12.1)	1.582	61.0 (16.1)	1.366	68.2 (20.1)	1.185	75.4 (24.1)	1.031	82.6 (28.1)	0.913
54.0 (12.2)	1.576	61.2 (16.2)	1.361	68.4 (20.2)	1.180	75.6 (24.2)	1.028	82.8 (28.2)	0.910
54.1 (12.3)	1.570	61.3 (16.3)	1.356	68.5 (20.3)	1.176	75.7 (24.3)	1.024	82.9 (28.3)	0.908
54.3 (12.4)	1.564	61.5 (16.4)	1.351	68.7 (20.4)	1.172	75.9 (24.4)	1.021	83.1 (28.4)	0.905
54.5 (12.5)	1.558	61.7 (16.5)	1.347	68.9 (20.5)	1.168	76.1 (24.5)	1.017	83.3 (28.5)	0.902
54.7 (12.6)	1.553	61.9 (16.6)	1.342	69.1 (20.6)	1.164	76.3 (24.6)	1.014	83.5 (28.6)	0.900
54.9 (12.7)	1.547	62.1 (16.7)	1.337	69.3 (20.7)	1.160	76.5 (24.7)	1.010	83.7 (28.7)	0.897
55.0 (12.8)	1.541	62.2 (16.8)	1.332	69.4 (20.8)	1.156	76.6 (24.8)	1.007	83.8 (28.8)	0.894
55.2 (12.9)	1.536	62.4 (16.9)	1.327	69.6 (20.9)	1.152	76.8 (24.9)	1.003	84.0 (28.9)	0.892
55.4 (13.0)	1.530	62.6 (17.0)	1.323	69.8 (21.0)	1.148	77.0 (25.0)	1.000	84.2 (29.0)	0.889
55.6 (13.1)	1.524	62.8 (17.1)	1.318	70.0 (21.1)	1.144	77.2 (25.1)	0.997	84.4 (29.1)	0.887
55.8 (13.2)	1.519	63.0 (17.2)	1.313	70.2 (21.2)	1.140	77.4 (25.2)	0.994	84.6 (29.2)	0.884
55.9 (13.3)	1.513	63.1 (17.3)	1.308	70.3 (21.3)	1.136	77.5 (25.3)	0.991	84.7 (29.3)	0.882
56.1 (13.4)	1.508	63.3 (17.4)	1.304	70.5 (21.4)	1.132	77.7 (25.4)	0.988	84.9 (29.4)	0.879
56.3 (13.5)	1.502	63.5 (17.5)	1.299	70.7 (21.5)	1.128	77.9 (25.5)	0.985	85.1 (29.5)	0.877
56.5 (13.6)	1.496	63.7 (17.6)	1.294	70.9 (21.6)	1.124	78.1 (25.6)	0.982	85.3 (29.6)	0.874
56.7 (13.7)	1.491	63.9 (17.7)	1.290	71.1 (21.7)	1.120	78.3 (25.7)	0.979	85.5 (29.7)	0.871
56.8 (13.8)	1.486	64.0 (17.8)	1.285	71.2 (21.8)	1.116	78.4 (25.8)	0.977	85.6 (29.8)	0.869
57.0 (13.9)	1.480	64.2 (17.9)	1.281	71.4 (21.9)	1.112	78.6 (25.9)	0.974	85.8 (29.9)	0.866

$^{\circ}\text{F}=(^{\circ}\text{C} \times 9/5) + 32$

Corrected Flow Rate= (Measured Flow Rate) \* (TCF @ Feed Water Temp.)





## Watts Commercial RO System

### Limited Warranty

Watts Regulator Co. (the "Company") warrants each product to be free from defects in material and workmanship under normal usage for a period of one year from the date of original shipment. In the event of such defects within the warranty period, the Company will, at its option, replace or recondition the product without charge.

**THE WARRANTY SET FORTH HEREIN IS GIVEN EXPRESSLY AND IS THE ONLY WARRANTY GIVEN BY THE COMPANY WITH RESPECT TO THE PRODUCT. THE COMPANY MAKES NO OTHER WARRANTIES, EXPRESS OR IMPLIED. THE COMPANY HEREBY SPECIFICALLY DISCLAIMS ALL OTHER WARRANTIES, EXPRESS OR IMPLIED, INCLUDING BUT NOT LIMITED TO THE IMPLIED WARRANTIES OF MERCHANTABILITY AND FITNESS FOR A PARTICULAR PURPOSE.**

The remedy described in the first paragraph of this warranty shall constitute the sole and exclusive remedy for breach of warranty, and the Company shall not be responsible for any incidental, special or consequential damages, including without limitation, lost profits or the cost of repairing or replacing other property which is damaged if this product does not work properly, other costs resulting from labor charges, delays, vandalism, negligence, fouling caused by foreign material, damage from adverse water conditions, chemical, or any other circumstances over which the Company has no control, including without limitation the use of incompatible chemicals and lubricants. This warranty shall be invalidated by any abuse, misuse, misapplication, improper installation or improper maintenance or alteration of the product, as well as any failure to install, operate or maintain the product in strict accordance and adherence with the product's operating documentation and manuals.

Some States do not allow limitations on how long an implied warranty lasts, and some States do not allow the exclusion or limitation of incidental or consequential damages. Therefore the above limitations may not apply to you. This Limited Warranty gives you specific legal rights, and you may have other rights that vary from State to State. You should consult applicable state laws to determine your rights. **SO FAR AS IS CONSISTENT WITH APPLICABLE STATE LAW, ANY IMPLIED WARRANTIES THAT MAY NOT BE DISCLAIMED, INCLUDING THE IMPLIED WARRANTIES OF MERCHANTABILITY AND FITNESS FOR A PARTICULAR PURPOSE, ARE LIMITED IN DURATION TO ONE YEAR FROM THE DATE OF ORIGINAL SHIPMENT.**



USA: T: (800) 659-8400 • [www.watts.com](http://www.watts.com)

Canada: T: (905) 332-4090 • [www.watts.ca](http://www.watts.ca)

Latin America: T: (52) 55-4122-0138 • [Watts.com](http://Watts.com)

