

Installation, Operation and Maintenance

LOCKSMITH™

1 1/4" Residential Filox® AIO Iron Filtration Systems

Model: FLLAIO-125

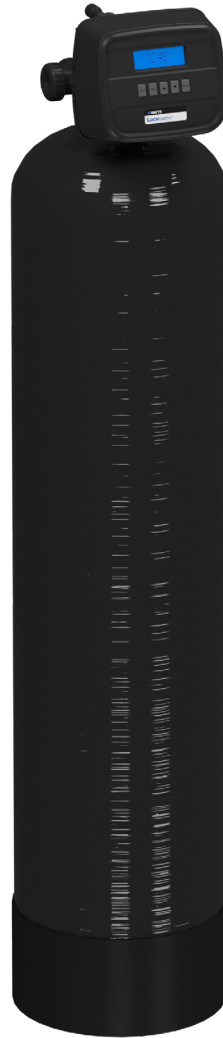

FLLAIO Iron Filtration Systems

Congratulations on your purchase of this Watts® Locksmith™ residential water filtration solution.

You have made a great choice to protect your plumbing system against the damaging effects of hard water. This system has been engineered for trouble free operation and produced using top quality components. Simple programming, corrosion resistant mineral tank and an easy to service design ensures this system will be durable and easy to maintain. Thank You!

The Watts Team

Backwashing filtration systems offer a range of benefits by removing sediment, chlorine, organic contaminants, and dissolved iron and manganese from the water supply. These systems help protect plumbing, water-using appliances, and fixtures from the buildup of particles, unpleasant tastes, and stains. By improving water quality, they also enhance the safety of drinking water, reducing exposure to harmful contaminants that can affect human health. Cleaner water supports overall wellness and reduces maintenance costs, while extending the lifespan of water heaters, fixtures, and other equipment, ensuring smooth operation with reduced downtime.

⚠ WARNING



Please read carefully before proceeding with installation. Your failure to follow any attached instructions or operating parameters may lead to the product's failure.



Keep this Manual for future reference.

⚠ WARNING

If you are unsure about installing your Watts backwash filtration system contact a Watts representative or consult a professional water treatment dealer or plumber.

You are required to thoroughly read all installation instructions and product safety information before beginning the installation of this product. FAILURE TO COMPLY WITH PROPER INSTALLATION AND MAINTENANCE INSTRUCTIONS COULD RESULT IN PRODUCT FAILURE WHICH CAN CAUSE PROPERTY DAMAGE, PERSONAL INJURY AND/OR DEATH. Watts is not responsible for damages resulting from improper installation and/or maintenance. Local building or plumbing codes may require modifications to the information provided. You are required to consult the local building and plumbing codes prior to installation. If this information is not consistent with local building or plumbing codes, the local codes should be followed.

Save manual for future reference.

Refer to the enclosed for operating parameters to ensure proper use with your water supply.

- As with all plumbing projects, it is recommended that a trained professional water treatment dealer or contractor install the water filtration system. Please follow all local plumbing codes for installing this water filtration system.
- Inspect the water filtration system for carrier shortage or shipping damage before beginning installation. Replace any damaged component immediately, before beginning installation.
- Use caution when installing soldered metal piping near the water filtration system. Heat can adversely affect the system's components.
- Use only lead-free solder and flux for sweat-solder connections, as required by state, province and federal codes.
- Handle all components of the system with care. Do not drop, drag or turn components upside down.
- Be sure the floor under the system is clean, level and strong enough to support the system while in operation.
- Install the system in a protected area.
- Do not attempt to treat water over 110°F (43°C) or under 34°F (1°C) with the system.
- Always connect the system to the main water supply pipe before the water heater.
 - The valve will withstand transportation and storage temperatures of -13°F (-25°C) to 131°F (55°C) and for short periods up to 158°F (70°C). If valve has been exposed to freezing conditions let valve warm up to room temperature before running water through it. The valve has been packaged to prevent damage from the effects of normal humidity, vibration and shock.
- Do not install in direct sunlight as overheating of electronics may occur and ultraviolet rays from the sun may cause damage. Exterior protection equipment is required for outdoor operation. Failure to follow outdoor installation requirements will void the warranty. Please consult Watts technicians before installing the system outside.
- Operating ambient temperature: 34° to 120°F (1° to 52°C).
- Operating water pressure range: 25 to 125psi (171 kPa to 8.6 bar).

- All plumbing connections to the system should be made using industry accepted best practices. Plumbing tape or paste may be used on metal inlet and outlet plumbing connections. Do not use paste type pipe thread sealants on the system's plastic plumbing connections.
- Do not use petroleum-based lubricants, oils or hydrocarbon-based lubricants on O-rings or valve seals. Use only 100% silicone lubricants.

NOTICE

Hydrocarbons such as kerosene, benzene, gasoline, etc may damage products that contain O-rings or plastic components. Exposure to such hydrocarbons may cause the products to leak. Do not use the product contained in this document on water supplies that contain hydrocarbons such as kerosene, benzene, gasoline, etc.

- Use only the power transformer supplied with this water filtration system.
- All electrical connections must be completed according to local codes.
- The power outlet must be grounded.
- For installations where plastic plumbing is used, install an appropriate grounding strap across the inlet and outlet piping of the building's metal plumbing to ensure that a proper ground is maintained.
- To disconnect power, unplug the AC adapter from its power source.
- Observe drain line requirements.
- Support the full weight of the plumbing system with pipe hangers or other means.
- Do not allow this water filtration system to freeze. Damage from freezing will void this water filtration system's warranty.
- It is established that when daytime water pressure exceeds 80psi (5.5 bar), the maximum pressure rating of 125psi (8.6 bar) can be exceeded. A pressure regulator **must be installed on this system or warranty is voided.**
- Periodic cleaning and maintenance is required for system to function properly.
- Observe all warnings that appear in this manual.
- Keep the media tank in the upright position. Do not turn upside down or drop. Turning the tank upside down or laying the tank on its side can cause media to enter the valve.
- Use only regenerants designed for water conditioning. Do not use ice melting salt, block salt or rock salt.

How To Use This Manual

This installation manual is designed to guide the installer through the process of installing and starting up this residential water filtration system.

This manual is a reference and will not include every system installation situation. The person installing this equipment should have:

- Training on the control valve.
- Knowledge of water filtration and how to determine proper control settings.
- Adequate plumbing skills.

⚠ WARNING

Do not use with water that is microbiologically unsafe or of unknown quality without adequate disinfection before or after the system.

Contents

How To Use This Manual	3
Introduction	4
Project Data Sheet	5
System Specifications	6
Control Valve Functions	7
Operating Parameters	7
System Installation.	8
Installation Instructions	12
Control Programing	14
OEM Filter System Setup.	15
Setting Options Table	18
Installer Display Settings	19
User Display Settings.	20
Installer Display Settings	21
Replacing the Media	22
System Components Described	23
Service Instructions	26
Drawings and Part Numbers	29
Flow Diagrams.	35
Troubleshooting.	37
Warranty	40

Introduction

Principals of Filtration- Backwash Systems

Water filtration is the removal of contaminants or particles from water through a filtering medium. This process, in which water passes through a filter media (such as activated carbon, or other media types), then traps and removes particles, debris, and/or other contaminants. Over time, the filter media will become clogged with these trapped particles, reducing filtration efficiency.

Locksmith FLLAIO systems are selected for use when the concentration of iron, manganese, and hydrogen sulfide in water need to be reduced. They use the Locksmith FLLAIO Control Valve to reduce the contaminants in the water without the use of chemicals. The FLLAIO valve is specially designed to capture a volume of air inside the system's mineral tank. Water passes through the control valve then passes through the air head in the top of the mineral tank. Oxygen from the captured air transfers into the water. The oxygen oxidizes the contaminants in the water to oxides or solid precipitants. Then they are mechanically filtered out of the water by the Filox media filter bed. The Filox media removes any residual iron, manganese, and hydrogen sulfide that has not formed into a solid by catalyzing it quickly into an oxide. After a preprogrammed number of days have passed, the system will perform a regeneration cycle to clean the Filox media of the solids it has accumulated, draw in more air, rinse, then return to service.

Backwashing is a cleaning method used to restore the filter media by reversing the flow of water through the filter media. This reverse of flow forces the trapped particles to loosen and move out of the filter media, allowing the filtration system to function properly again. During this backwashing process, water is sent in the opposite direction of normal filtration flow. In filters that use granular media, the backwash causes the media to expand. With the increased velocity of the backwash and expansion of the filter bed, the accumulated dirt and debris is released and carried away through a drainage system. This process creates space for new contaminants to be captured during the next filtration cycle.

Backwashing is typically performed at regular intervals, depending on factors such as the volume of water processed, the number of contaminants, and the type of filter. The backwash cycle duration is automated, ensuring effective cleaning without wasting too much water or time. The backwash process is highly effective in maintaining filtration efficiency, especially in systems dealing with large amounts of particulates. It extends the life of the filter media and ensures the continued quality of the filtered water. It is a critical maintenance process that helps restore filter media, ensuring that filtration systems continue to operate efficiently by removing the particles that accumulate during normal filtration.

Regeneration occurs automatically and consists of 3 steps:

Step 1- Backwash

Approximate Duration 14 Minutes- Fresh water flow is directed reversed through the media bed to remove solid particles the media bed has captured, sending them to drain.

Step 2- Air Draw

Approximate Duration 40 Minutes- Air Draw empties water from the tank and replenishes the oxygen within the mineral tank.

Step 3- Rapid Rinse

Approximate Duration 1 Minute- After the conclusion of the Air Draw, Rapid Rinse purges excess atmosphere from the mineral tank and distributor before it returns to service.

Project Data Sheet

Installation Summary

Installation Date: _____

Installation Location: _____

Installer(s): _____

Phone Number: _____

Application Type: (Softener) _____ Other: _____

Water Source: _____

Water Test Results: _____

Hardness: _____ Iron: _____ pH: _____

Other: _____

Misc:

Service Flow Rates: min. _____ max. _____

Tank Size: Diameter _____ Height: _____

Resin or Media Volume: _____

Resin or Media Type: _____

Capacity: _____

Salt or Fill Setting per Regeneration: _____

Brine Tank Size: _____

Control Valve Configuration:

Valve Type: _____

Valve Part Number: _____

Valve Serial Number: _____

Regenerant Refill Control: _____ gpm/lpm

Injector Size: _____

Drain Line Flow Control: _____ gpm/lpm

System Specifications

Dimensions - Weights

Series FLLAIO-125

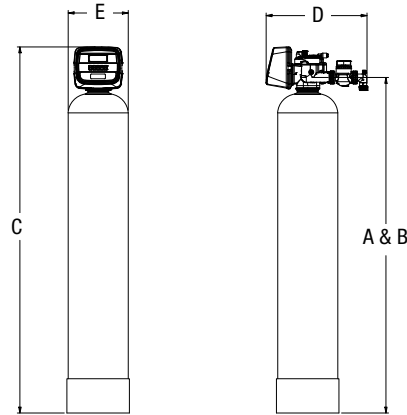

Series FLLAIO-125

Call customer service if you need assistance with technical details.

Model No.	Dimensions										Weight	
	A		B		C		D		E		lb	kg
	<i>in.</i>	<i>mm</i>	<i>in.</i>	<i>mm</i>	<i>in.</i>	<i>mm</i>	<i>in.</i>	<i>mm</i>	<i>in.</i>	<i>mm</i>		
N2349-FAIO	50 1/2	1283	50 1/2	1283	55 1/2	1410	11 3/4	298	9 1/2	241	167	76
N2350-FAIO	56 1/2	1435	56 1/2	1435	61 3/4	1568	12 1/4	311	10 1/2	267	235	107
N2351-FAIO	55	1397	55	1397	60	1524	13 1/4	337	12 1/2	318	318	144

Specification and Ordering Information

MODEL NO.	ORDERING CODE	TANK SIZE	MEDIA (CU FT)	PEAK SERVICE FLOW (GPM)	BACKWASH (GPM)	FLOOR SPACE (DXWXH)	SHIP WT. (LBS.)
N2349-FAIO	68112352	9x48	1	6	7.5	12" x 10" x 56"	167
N2350-FAIO	68112353	10x54	1.5	9	10	12" x 11" x 62"	235
N2351-FAIO	68112354	12x52	2	12	15	13" x 13" x 60"	318

Control Valve Functions

Control Valve Function and Cycles of Operation

This glass filled Noryl fully automatic control valve is designed as the primary control center to direct and regulate all cycles of a backwashing filter system. The control valve can be set to regenerate on demand (consumption of a predetermined amount of water) and/or as a time clock (passage of a particular number of days).

The control valve is compatible with a variety of regenerants and resin cleaners. The control valve is capable of routing the flow, of water in the necessary paths to regenerate or backwash water treatment systems. The injector regulates the flow of brine or other regenerants. The control valve regulates the flow rates for backwashing, rinsing and the replenishing of treated water into a regenerant tank.

The control valve is designed to deliver high service (27 gpm @ 15psid) and backwash (27 gpm @ 25psid) flow rates when the bypass has straight fittings. The control valve uses no traditional fasteners (e.g. screws), instead clips, threaded nuts and snap type latches are used, do not use pliers to tighten the nuts. Nuts only need to be firmly hand tightened because radial seals are used. Tools required to service the valve include one small blade screwdriver, one large blade screwdriver, pliers and a pair of hands. A plastic wrench is available which eliminates the need for screw-drivers and pliers. Disassembly for servicing takes much less time than comparable products currently on the market.

The transformer power pack comes with a 15-foot power cord and is designed for use with the control valve. The transformer power pack is for dry location use only. The control valve remembers all settings for two hours if the power goes out. After two hours the only item that needs to be reset is the time of day, all other values are permanently stored in the nonvolatile memory. The control valve does not need batteries.

Backwashes can be set to be NORMAL or LONGER. The option selected will apply to all backwashes.

Operating Parameters

Water Pressure.	30 psi to 80 psi (205 kPa to 5.5 bar)
Temperature	34 - 110°F (1 - 43°C)
pH	6.56 to 9
H2S	Up to 3 ppm
Iron.	Up to 10 ppm
Manganese	Up to 5 ppm

Water known to have heavy loads of dirt and debris may require pre-filtration prior to the water filtration system.

For all other guideline information please contact your Watts representative.

NOTICE

Due to the presence of air in the media tank the maximum operating pressure of the system is 80 psi.

System Installation

Installation Guidelines

Control Valve:

- This glass filled Noryl (or equivalent) fully automatic control valve is designed as the primary control center to direct and regulate all cycles of a water softener or filter.
- The control valve, fittings and/or bypass are designed to accommodate minor plumbing misalignments but are not designed to support the weight of a system or the plumbing.
- The nuts and caps are designed to be unscrewed or tightened by hand or with the special plastic wrench. If necessary pliers can be used to unscrew the nut or cap. Do not use a pipe wrench to tighten or loosen nuts or caps. Do not place a screwdriver in the slots on caps and/or tap with a hammer.
- After completing any valve maintenance involving the drive assembly or the drive cap assembly and pistons unplug power source jack from the printed circuit board (black wire) and plug back in or press and hold NEXT and REGEN buttons for 3 seconds. This resets the electronics and establishes the service piston position. The display should flash all wording, then flash the software version and then reset the valve to the service position.
- The control valve is compatible with a variety of regenerants and resin cleaners. The control valve is capable of routing the flow of water in the necessary paths to regenerate or backwash water treatment systems. The injector regulates the flow of brine or other regenerants. The control valve regulates the flow rates for backwashing, rinsing, and the replenishing of treated water into a regenerant tank, when applicable.
- Control valve installation is made easy because the distributor tube can be cut 1/2" above to 1/2" below the top of tank thread. The distributor tube is held in place by an O-ring seal and the control valve also has a bayonet lock feature for upper distributor baskets.

Pre-Installation Considerations

A. Water Pressure

A minimum of 25 pounds of water pressure is required for regeneration valve to operate effectively. Do not exceed maximum water pressure of 125 pounds of water pressure.

B. Electrical Facilities

A continuous 120 volt, 60 Hertz current supply is required. Make certain the current supply is always hot and cannot be turned off with another switch.

⚠ WARNING

As with any electrical product, care should be taken to guard against the potential risk of fire, electric shock, and injury to persons.

C. Existing Plumbing

Condition of existing plumbing should be free from lime and iron buildup. Piping that is built up heavily with lime and/or iron should be replaced. If piping is clogged with iron, a separate iron filter unit should be installed ahead of the filtration system.

D. Where to Install the Filtration System

Consider the following points when determining where to install the filtration system:

- Place the system as close as possible to a sewer drain.
- Do not install the filtration system where it would block access to the waterheater, or access to the main water shutoff, water meter, or electrical panels.
- Keep outside faucets on hard water to save soft water and salt.
- Install the filtration system in a place where water damage is least likely to occur if a leak and that caution should be used in determining the placement of the system in a home to reduce water damages in the event a leak occurs..
- A 120VAC electrical outlet is needed to plug in the transformer. If the outlet is remote (up to 100 feet), use 18 gauge wire to connect.
- Always connect the system to the main water supply pipe before the water heater.
- Install the system where it will not be subject to temperatures outside of the limits stated in the Specification section or to direct sunlight.

E. Bypass Valves

Always provide for the installation of a bypass valve.

F. Valve to Tank Installation Instructions

1. Spin the valve onto the tank, ensuring the threads are free of media and are not cross-threaded.

NOTICE

The control valve has right-hand threads, or clockwise, to install.

2. Rotate the valve freely without using force until it comes to a stop (this position is considered zero).
3. Rotate the valve clockwise from zero, between ¼ turn and ½ turn to fully tighten. No tools are needed. Hand tight is enough. Overtightening may cause valve or tank damage.

NOTICE

If lubricant is required, a silicone compound is strongly recommended. Silicone compound available from Watts (Ordering code 68102757), is recommended for best possible results. Dow Corning® 7 Release Compound is used in the manufacture of this control valve. The use of other types of lubricants may attack the control's plastic or rubber components. Petroleum-based lubricants can cause swelling in rubber parts, including O-rings and seals and may compromise product performance.

Pre-Installation Considerations (continued)

G. Pre-Installation and Loading of Media

Systems that are 13" in diameter and larger are not loaded with media. These systems must be loaded with media before placing into service. To load a system follow the below steps.

1. Cap the top open end of the distributor tube with tape and plastic sheeting to keep foreign debris from entering the distributor tube. This cap must be secure and not come off during media loading.
2. Place the distributor tube, screen end down, into the mineral tank and center it in the bottom. The top of the distributor tube should be flush with the top of the tank.
3. Make sure the plastic and tape cap is secure to the top of the distributor tube, place a funnel on the top of the tank and load first the gravel (if different sizes of gravel are used load the largest gravel first, then the smaller gravel) then the resin media into the tank. The cap must not come off of the distributor tube during the loading of the media.
4. Remove the plastic cap from the distributor tube. **DO NOT PULL UP ON THE DISTRIBUTOR TUBE** when removing the cap. The distributor tube top must remain flush with the top of the tank.
5. Clean any media from the threads and top of the mineral tank.
6. Lubricate the O-rings on the bottom of the control valve (distributor pilot O-ring and top of tank O-ring). Use non-petroleum based silicone lubricant only.
7. Place the control valve on top of the tank. When doing this step, seat the top of the distributor tube inside the centered O-ring sealed port on the bottom of the valve first then press the valve down until the tank threads come in contact with the valve threads. This ensures that the distributor tube is properly seated into the bottom of the control valve. Thread the valve on to the tank clockwise. Be careful not to cross thread the valve or over tighten it. A hand tight snug fit is appropriate for the control valve torque. A wrench is not necessary. Do not use thread sealant or PTFE tape on the valve base threads.
8. The system is now ready for installation. Follow the Installation Section in the Installation, Operation and Maintenance Manual.

Installation Preview

Conduct a visual check of all equipment for any damage that may have occurred during shipment.

NOTICE

If there is obvious damage to any equipment, it should be noted on the carrier's Bill Of Lading. Open and inspect the contents of all closed crates, cartons, etc. and inspect for concealed damage. The manufacturer is not liable for any damage during transit.

Position the equipment in its proper location, setting on a flat surface. Level equipment as required. Equipment out of plumb can exhibit poor flow characteristics, which will affect the performance of the system.

NOTICE

Units are shipped with media (resin & gravel), distributions tube, and control valve installed. Double-check the valve installation on the tank. Tighten if necessary.

Unit should be positioned with the valve control facing forward.

Check the main line water pressure. The filtration system is designed for a minimum of 25 psi and a maximum of 125 psi working pressure. If the line pressure exceeds this limit, a pressure-reducing valve should be installed.

Water temperature operating range is 40°F (4°C) – 110°F (43°C). A 120vac 60 cycle electrical source must be available for operation of the controller.

Connect raw water supply line to the inlet valve connection. Connect treated water outlet to service line. It is suggested that the pipe size be equal or one size larger than the valve connection.

NOTICE

Filtration system to be located at least 10 feet away from hot water heater to protect against hot water back-up.

⚠ WARNING

When piping with copper, solder all piping as sub-assemblies before installing. Internal damage can result from the high heat of the torch.

It is recommended that manual isolating valves be installed on the inlet and outlet piping along with a system bypass valve. This will isolate the unit when service is required. Run drain line to a sump, drain trench, or other open drain. Open drains are required for taking samples and allowing a visual check. Avoid overhead pipe runs to drain facility, as undue backpressure will affect the operation of injectors.

NOTICE

All piping is to meet your local and state code. **AVOID CROSS CONNECTIONS!**

Be sure inlet/outlet isolating valves are closed and bypass valve is open.

⚠ WARNING

Do not exceed water pressure of 125 psi (8.5 bar). Do not exceed 110°F (43.3°C). Do not subject unit to freezing conditions.

Installation Instructions

1. Turn off water heater(s).
2. Turn off the main water supply to the home and open an inside faucet (cold and hot) to relieve any pressure within the plumbing system.

Select Location

3. Place the system in the desired installation location. Make sure that the location is level and sturdy enough to support the weight of the system once it is in operation.
4. You will need to locate the filtration system at least 10 feet away from the hot water heater so that hot water does not backup and damage the system.
5. You will need a drain close by for disposal of regenerated wastewater.
6. If installing the filtration system in an outside locations, make sure to protect the system from the elements, such as freezing temperatures, rain, sunlight and contamination

Install a Bypass

NOTICE

Always install a bypass, either a 3 valve bypass or the standard bypass for the system you have. This will allow you to shut off the water supply to the filtration system, but still have water in the house if the system is in need of repair.

After a location has been determine install bypass onto the control valve. (On page 11, Figures 1 and 3 show standard bypass on valve.) (Figures 2 and 4 show 3 valve bypass plumbing.)

NOTICE

If installing a 3 valve bypass valve, do so now.

Close main water supply valve, at the well or at the water meter.

Shut off electrical or fuel supply to the water heater before beginning the installation of this product.

Open all faucets to drain pipes.

NOTICE

The bypass (provided) easily connects to the valve body using nuts that only require hand tightening. The split ring retainer design holds the nut on and allows load to be spread over the entire nut surface area reducing the chance for leakage.

Make certain the nut is placed on first, then the split retainer ring, followed by the O-ring to make the seal. A silicon lubricant may be used on the black O-ring seals. This design allows for an approximate 2-degree misalignment of the plumbing. **This design will allow for minor plumbing misalignments, but should never handle the weight of the plumbing system.**

System Components Described

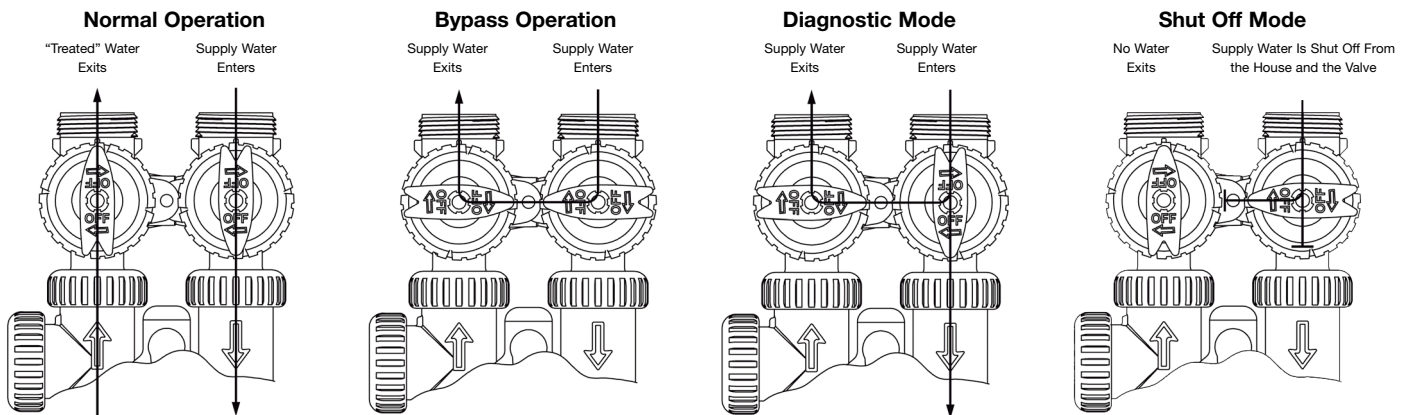

Bypass Valve Installation

NOTICE

Backwashing Filtration system connections follow the same method as shown in the images below, with the exception of the brine tank and brine connections.

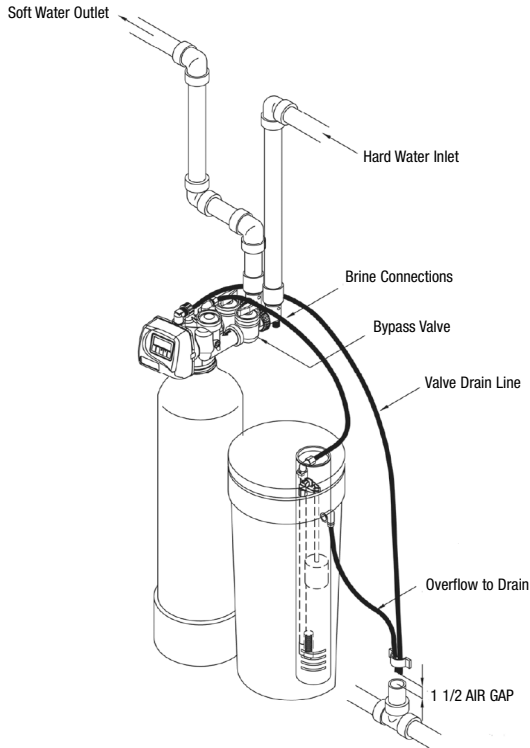

Figure 1: Plumbing with bypass (Standard).

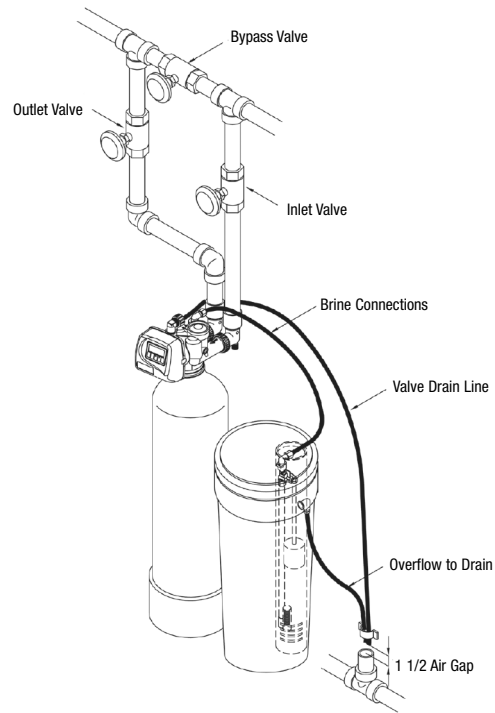

Figure 2: Plumbing with 3 valve bypass.

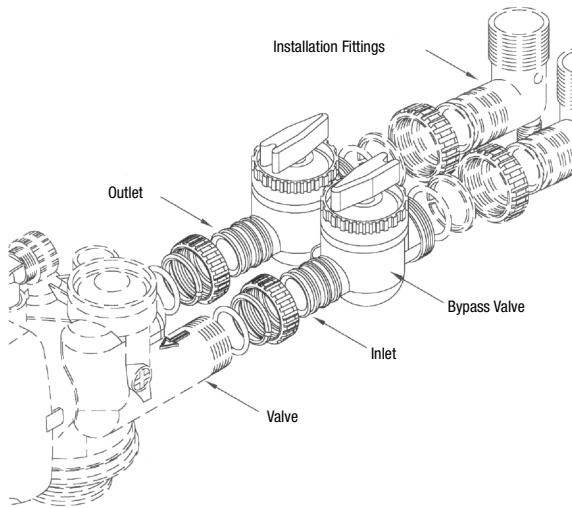

Figure 3: Bypass (standard).

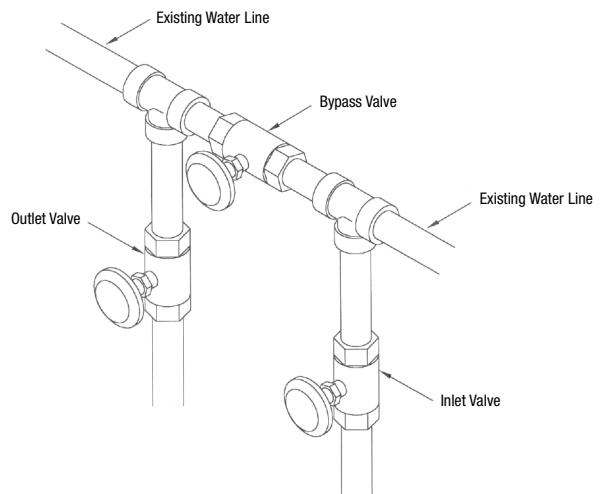

Figure 4: 3 Valve bypass plumbing.

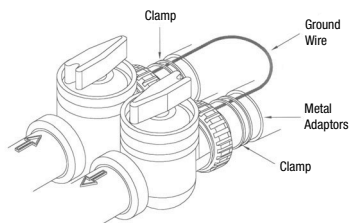

Figure 5:

When installing sweat copper follow state and federal codes by using a lead free solder and flux. Use a joint compound to seal threaded pipe. Some homes use the cold water pipes for an electrical ground (metal only). When finished with plumbing, a ground/bonding wire should be connected to the copper pipes to complete the ground circuit. Use two clamps and #4 copper for this.

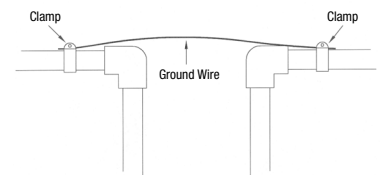

Figure 6:

Installation Instructions

Move Filter System Into Place

1. Make sure floor is level.

NOTICE

When assembling the plumbing adapter fittings, connect the fitting to the plumbing system first and then attach the nut, split ring and O-ring. Heat from soldering or solvent cements may damage the nut, split ring, and O-ring. Make sure solder joints are cool before assemble is started.

Split ring retainer design holds the nut on and allows load to be spread over the entire nut surface area reducing the chance for leakage. The split ring design, incorporated into the plumbing adapters allows approximately 2 degrees off axis alignment to the plumbing system. The plumbing adapters are designed to accommodate minor plumbing misalignments but are not designed to support the weight of a system or the plumbing.

When assembling the plumbing adapters package, connect the fitting to the plumbing system first and then attach the nut, split ring and O-ring. Heat from soldering or solvent cements may damage the nut, split ring, or O-ring. Solder joints should be cool and solvent cements should be set before installing the nut, split ring, and O-ring. Avoid getting primer and solvent cement on any part of the O-rings, split rings, and bypass valve or control valve. Solvent cements and primers should be used in accordance with the manufacturer's instructions.

Measure, cut, and install pipe and fittings to the bypass valve (dry fit only to make sure you have a proper fit) inlet and outlet side. Be sure hard water is supplied to the inlet side. Trace pipe to be sure.

The plumbing adapters connect to the control valve or the bypass valve using nuts that only require hand tightening. Hand tighten nut connections between control valve and plumbing adapters, control valve and bypass valve, and bypass valve and plumbing adapters allow for easy serviceability.

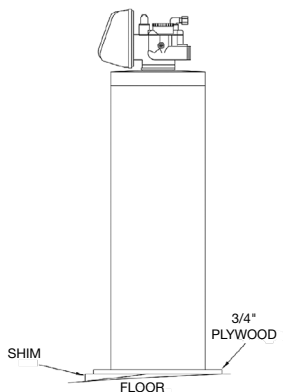

⚠ WARNING

Do not use a pipe wrench to tighten nuts on plumbing adapters. Hand tighten only.

2. Connect the cold water supply to the inlet of the water conditioning system. While constructing the supply line, install a master supply valve (user supplied) in the supply line and close it.
3. Connect the feed water line to the home to the outlet of the system.

- 1 1/4" - 1 1/2" PVC Solvent
(Included)
- 1" PVC Male NPT Elbow
(Optional)
- 3/4" - 1" PVC Solvent Elbow
(Optional)

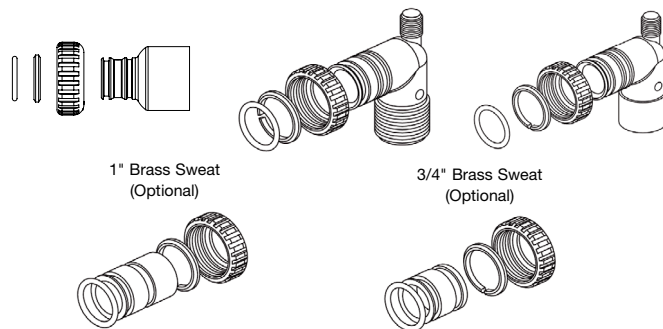

Five types of Inlet/Outlet Plumbing Adapters.

Assembling the Inlet/Outlet Plumbing Adapters

Slip the nut onto the fitting first, then the split ring second and the O-ring last. Hand tighten the nut. If the fitting is leaking tightening the nut will not stop the leak. Remove the nut, remove the fitting, and check for damage or misalignment of the O-ring.

Do not use pipe dope or other sealant on threads of the bypass to plumbing adapters connection or the bypass to control valve connection. PTFE tape must be used on the threads of the 1" NPT elbow and the 1/4" NPT connection of the plumbing adapters and on the threads for the drain line connection. PTFE tape is not necessary on the nut connection because of O-ring seals.

Connect the Drain Line

NOTICE

Due to the release of air during regeneration, the drain line should be anchored throughout the run, secured at the end of the drain line, and properly vented.

1. Plumb the drain line to an appropriate drain abiding by all local, city, and state codes. Use a 3/4" drain line for backwash flow rates of 7 gpm or for drain lines of 7 gpm and less that exceed 20' in length. Use a 1" drain line for backwash flow rates of 10 gpm and 12 gpm.
2. If the drain line is a 5/8" outside diameter X 1/2" inside diameter flexible poly tube, slide the nut onto the poly tube, then place the poly tube insert into the end of the poly tube and tighten the nut on to the 3/4" drain line fitting. The nut is only designed for use with flexible poly tube. Use other nuts if attaching different materials. Run line to a drain. Making sure you have a 1 1/2" airgap. You may use a floor drain, standpipe or any open type drain (see Fig. 7 on page 13). Do not use petroleum-based, oils, or other unacceptable lubricants on O-rings. A silicon lubricant may be used on the black O-ring.

Use pliers to tighten or unscrew the nut. Do not use a pipe wrench to tighten or loosen nut. Do not use pipe dope or other sealant on threads. Use PTFE tape on the threads of the drain line control fitting when installing 3/4" NPT onto the 3/4" male threads of the drain fitting. When connecting to the drain fitting using the compression nut and insert, do not use PTFE tape on the threads of the drain elbow.

A 3/4" Female NPT X 1/2" Male hose barb fitting is also provided to connect 1/2" inside diameter hose to the drain fitting. Be sure to secure the hose to the hose barb with a clamp.

Be certain to anchor the discharge end of the drain line so it can not move. Water damage may result if the drain hose is not properly secured and anchored.

Installation

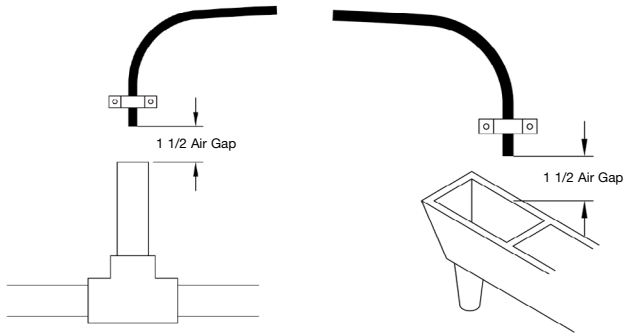

Figure 7: Also be sure drain line has an air gap.

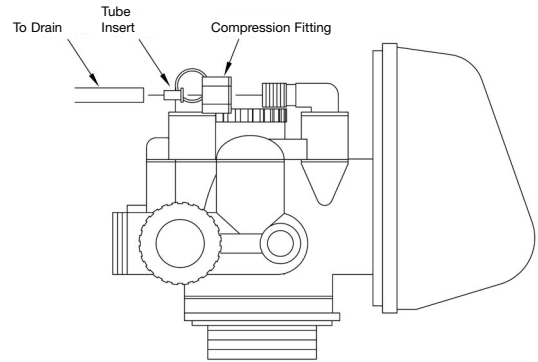

Figure 8: Drain Line Connection using Compressions Nut

Start Up

1. Confirm that the bypass valve is in the bypass position (see images 10 & 11 below)
2. Place the bypass valve in the "bypass" position or mode (see figures 10 & 11 below.)
3. Open the master water supply to the home. Check for leaks and repair as needed.
4. Initiate an Immediate Manual Regeneration by pressing and holding the "REGEN" button for 3 seconds. This will place the system into "Backwash" mode, unplug the system from its electrical outlet once it has cycled into the backwash position. This will stall the unit in the "Backwash" mode so all air can be purged from the tank.
5. Open the outlet valve of the bypass.
6. Adjust the user supplied feed water valve to the slightly open position until water can barely be heard flowing through the valve. Then place the bypass valve into the "Service/ Operating Mode" position.
7. Open a couple inside hot and cold faucets until all air has been purged from the plumbing system. Then close the faucets.
8. Allow system to fill with water until water flow is observed at the drain line discharge end. Air will come out of the drain line until the backwashing tank is completely purged of air. Then water will flow to drain. Allow water to flow to drain for 30 minutes or until the water to drain is clear of carbon fines. After water has been flowing to drain for 30 minutes slowly, fully open the user supplied valve and allow to flush until the water at the drain discharge is clear.
9. Plug the system back into the electrical outlet and manually cycle the control valve through the remaining regeneration steps by pressing the "Next" button until it arrives in the Service position.
10. Check for system for leaks and repair as needed.
11. Open cold side faucets in the home and flush water to purge any air that is captured in the plumbing system. Then restore power/gas to water heaters and turn water heaters on.
12. Installation is now complete and the system is ready for programming.

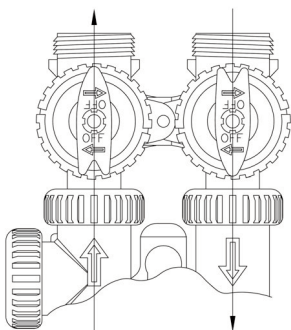

Figure 9: Operating Mode

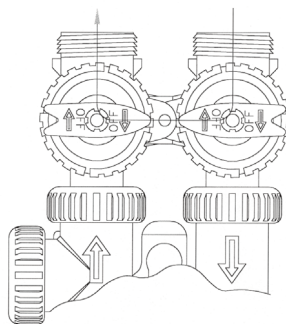

Figure 10: Bypass Mode

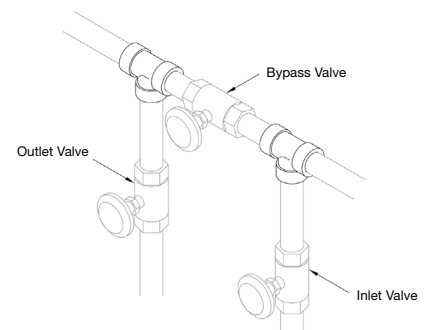

Figure 11: Bypass Mode

Control Programing

DIR	TIME CLOCK	RESERVE CAPACITY	FILTER			SETTINGS	
			SOFTNER	REGENERANT	BACKWASH ONLY	DAY OVERRIDE	VOLUME CAPACITY
YES		Automatically Calculated Yes Off Auto	YES			OFF	AUTO
YES		If desired enter a value less than estimated capacity	YES	YES	YES	OFF	ANY NUMBER
YES	YES	Automatically Calculated	YES			ANY NUMBER	AUTO
YES	YES	If desired enter a value less than estimated capacity	YES	YES	YES	ANY NUMBER	ANY NUMBER
	YES	None	YES	YES	YES	ANY NUMBER	OFF

* Day override AND Gallon Capacity cannot be set to "off" at the same time

Quick Programming Overview

Initial Setup: Press NEXT & ▼

1. Configuration Filtering DN Post
2. Cycle Durations*
3. Volume Capacity OFF

Installer Setup: Press NEXT & ▲

1. Hardness "grains"
2. Day Override
3. Time of Regeneration 12:00AM
4. Energy Saver
5. Installer Contact Info

Diagnostics: Press ▼ & ▲

1. Number of days since last regeneration
2. Number of gallons since last regeneration
3. Reserve capacity gallons used in last 7 days
4. Daily gallon usage for last 63 days
5. Maximum flow rate in the last seven days

Valve History: Press ▼ & ▲ then ▼ & ▲

1. Software version
2. Total number of days since start-up
3. Total Number of regeneration since start-up
4. Total number of gallons since start-up
5. Last 10 error occurrences

* Refer to Control Valve Functions on page 7

Figure 12: Key Pad

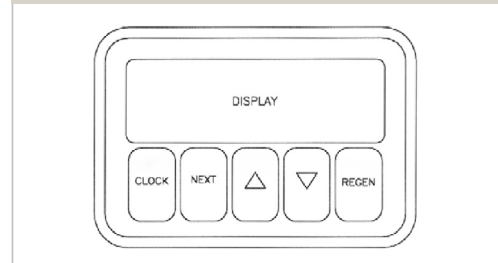

There are three choices for settings:

1. **DELAYED REGENERATION:** Regeneration will occur at the preset time.
2. **IMMEDIATE REGENERATION:** Regeneration will occur immediately when the volume capacity reaches zero. Once the valve has completed the immediate regeneration, the valve will regenerate one more time at the preset regeneration time.
3. **DELAY + IMMEDIATE REGENERATION:** Regeneration will occur at the preset time when the volume capacity falls below the reserve or the specified number of days between regenerations is reached, whichever comes first; or immediately after 10 minutes of no water usage when the volume capacity reaches zero.

The user can initiate manual regeneration. Sometimes, it is desirable to have the valve initiate and complete 2 regenerations within 24 hours and then return to the preset regeneration procedure. It is possible to do a double regeneration if Regeneration Time Option is set to DELAYED REGEN or DELAY + IMMEDIATE. To do a double regeneration:

1. Press REGEN once. REGEN TODAY will flash on the display and the regeneration will occur at the delayed regeneration time. The user can cancel the request by pressing and releasing the REGEN button. This method of manually initiating regeneration is not allowed when the system is set to immediately regenerate when the capacity reaches zero.
2. Press and hold the REGEN button for approximately 3 seconds to will immediately start the regeneration. The user cannot cancel this request, except by resetting the control by pressing NEXT and REGEN buttons simultaneously for 3 seconds.

OEM Filter System Setup

STEP 1F

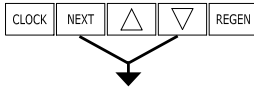

Step 1F – Press NEXT and ▼ simultaneously for 3 seconds and release. If screen in Step 2F does not appear in 5 seconds, the lock on the valve is activated. To unlock, press ▼, NEXT, ▲, and CLOCK in sequence, and try again.

STEP 2F

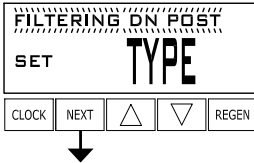

Step 2F – Use ▼ or ▲ to select *FILTERING DN POST*. Press NEXT to go to Step 3F. Press REGEN to exit OEM Filter System Setup.

STEP 3F

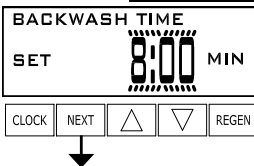

Step 3F – Use ▼ or ▲ to select the time for the first cycle. Value ranges and units will vary depending on the cycle, see Table below for more detail. Press NEXT to set the value for the next cycle. Repeat for all cycles. Once a value is set for all cycles, press NEXT to go to Step 4F. Press REGEN to return to previous step.

Filtering Cycle Sequence Ranges

CYCLE	UNITS	RANGE	DEFAULT
Backwash	Minutes	1 – 120 or OFF	8
Rinse	Minutes	1 – 120 or OFF	4
Draw (Up or Down)	Minutes	1 – 160 or OFF	60
Fill (all but 2" valve)	Gallons	0.05 – 20 or OFF	0.95
Fill (2" valve)	Minutes	0.1 – 99 or OFF	6

STEP 4F

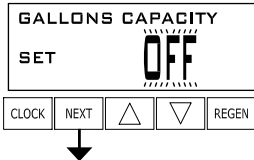

Step 4F – Volume Capacity: Use ▼ or ▲ to select one of the following options:

- *OFF*: Regeneration will be based solely on the Day Override set in Step 3I.
- A number: Regeneration initiation will be based off the value specified.

See Setting Options Table for more detail.

Press NEXT to go to Step 5F. Press REGEN to return to previous step.

STEP 5F

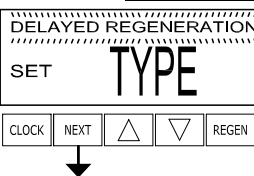

Step 5F – Regeneration Time Option: Use ▼ or ▲ to select one of the following options:

- *DELAYED REGENERATION*: Regeneration will occur at the preset time.
- *IMMEDIATE REGENERATION*: Regeneration will occur immediately when the volume capacity reaches 0 (zero).
- *DELAY + IMMEDIATE REGENERATION*: Regeneration will occur at one of the following:
 - The preset time when the volume capacity falls below the reserve or the specified number of days between regenerations is reached, whichever comes first; or
 - Immediately after 10 minutes of no water usage when the volume capacity reaches 0 (zero).

This display will not appear if Step 4F is set to *OFF*.

See Setting Options Table for more detail.

Press NEXT to go to Step 6F. Press REGEN to return to previous step.

OEM Filter System Setup

STEP 6F

REGEN TIME				
SET RELAY 1				
CLOCK	NEXT	▲	▼	REGEN



Step 6F – Relay 1 Output: Use ▼ or ▲ to select one of the following options:

- **REGEN TIME:** Relay activates a set time after the start of regeneration and deactivates after a set period of time. The start of regeneration is defined as the first regeneration cycle that is NOT Fill, Softening, or Filtering.
- **VOLUME:** Relay activates after a set volume has been used while in service and deactivates after the meter stops registering flow and the set time period has expired.
- **REGEN VOLUME:** Relay activates after a set volume of water has been used while in service or during regeneration and deactivates after the meter stops registering flow and the set time period has expired.
- **LOW SALT LEVEL:** Relay activates when the Salt Level Alarm set in Step 10S is triggered and will deactivate until the salt level is reset. This relay will continue operation during a power outage or during error mode. Step 6F(A) and Step 6F(B) will not appear if this option is selected.
- **OFF:** Feature not used. Step 6F(A) and Step 6F(B) will not appear if this option is selected.

Press NEXT to go to Step 6F(A) or Step 7F. Press REGEN to return to previous step.

STEP 6F(A)

RELAY 1 SETPOINT				
SET 10 MIN				
CLOCK	NEXT	▲	▼	REGEN



Step 6F(A) – Relay 1 Actuation: Use ▼ or ▲ to set the actuation value. The unit and range will vary depending on the selection in Step 6F.

- **Regen Time:** Set the length of time after the start of regeneration prior to relay activation (Range: 0 – 500 minutes). The start of regeneration is defined as the first regeneration cycle that is NOT Fill, Softening, or Filtering.
- **Volume or Regen Volume:** Set the volume of water that will be treated prior to relay activation (Range: 0.1 – 20,000 gallons).

Press NEXT to go to Step 6F(B). Press REGEN to return to previous step.

STEP 6F(B)

RELAY 1 DURATION				
SET 5:00 MIN				
CLOCK	NEXT	▲	▼	REGEN



Step 6F(B) – Relay 1 Duration Time: Use ▼ or ▲ to set the length of time the relay will stay active prior to deactivation (Range: 1 second – 500 minutes). If Step 6F is set to **VOLUME** or **REGEN VOLUME**, the relay will deactivate after the time set has expired or after the meter stops registering flow, whichever comes first.

Press NEXT to go to Step 7F. Press REGEN to return to previous step.

STEP 7F

VOLUME				
SET RELAY 2				
CLOCK	NEXT	▲	▼	REGEN



Step 7F – Relay 2 Output: Use ▼ or ▲ to select one of the following options:

- **REGEN TIME:** Relay activates a set time after the start of regeneration and deactivates after a set period of time. The start of regeneration is defined as the first regeneration cycle that is NOT Fill, Softening, or Filtering.
- **VOLUME:** Relay activates after a set volume has been used while in service and deactivates after the meter stops registering flow and the set time period has expired.
- **REGEN VOLUME:** Relay activates after a set volume of water has been used while in service or during regeneration and deactivates after the meter stops registering flow and the set time period has expired.
- **ERROR MONITOR:** Relay activates when the control enters an error state and immediately deactivates when the control exits the error state. Step 7F(A) and Step 7F(B) will not appear if this option is selected.
- **OFF:** Feature not used. Step 7F(A) and Step 7F(B) will not appear if this option is selected.

Press NEXT to go to Step 7F(A) or Step 8F. Press REGEN to return to previous step.

OEM Filter System Setup

STEP 7F(A)

RELAY 2 SETPOINT	
SET	20.0 GAL
CLOCK	NEXT <input type="button" value="▲"/> <input type="button" value="▼"/> REGEN

Step 7F(A) – Relay 2 Actuation: Use ▼ or ▲ to set the actuation value. The unit and range will vary depending on the selection in Step 7F.

- Regen Time: Set the length of time after the start of regeneration prior to relay activation (Range: 0 – 500 minutes). The start of regeneration is defined as the first regeneration cycle that is NOT Fill, Softening, or Filtering.
- Volume or Regen Volume: Set the volume of water that will be treated prior to relay activation (Range: 0.1 – 20,000 gallons).

Press NEXT to go to Step 7F(B). Press REGEN to return to previous step.

STEP 7F(B)

RELAY 2 DURATION	
SET	5:00 MIN
CLOCK	NEXT <input type="button" value="▲"/> <input type="button" value="▼"/> REGEN

Step 7F(B) – Relay 2 Duration Time: Use ▼ or ▲ to set the length of time the relay will stay active prior to deactivation (Range: 1 second – 500 minutes). If Step 7F is set to *VOLUME* or *REGEN VOLUME*, the relay will deactivate after the time set has expired or after the meter stops registering flow, whichever comes first.

Press NEXT to go to Step 8F. Press REGEN to return to previous step.

STEP 8F

SERVICE ALARM	
SET	BOTH
CLOCK	NEXT <input type="button" value="▲"/> <input type="button" value="▼"/> REGEN

Step 8F – Scheduled Service Alarm: Use ▼ or ▲ to select one of the following options:

- *TIME*: Activates the service alarm after a set duration of time.
- *GALLONS*: Activates the service alarm after a set volume of water is treated.
- *BOTH*: Activates the service alarm after a set duration of time and after a set volume of water is treated, whichever comes first.
- *OFF*: Disables this feature. Step 8F(A) – Step 8F(D) will not appear if this option is selected.

Press NEXT to go to Step 8F(A) or to exit OEM Filter System Setup. Press REGEN to return to previous step.

STEP 8F(A)

SCHEDULED SERVICE	
SET	1.25 YR
CLOCK	NEXT <input type="button" value="▲"/> <input type="button" value="▼"/> REGEN

Step 8F(A) – Service Alarm Time: Use ▼ or ▲ to set the length of time between service alarms (Range: 0.25 – 9.75 years). This display will only appear if Step 8F is set to *TIME* or *BOTH*.

Press NEXT to go to Step 8F(B) or Step 8F(C). Press REGEN to return to the previous step.

STEP 8F(B)

SCHEDULED SERVICE	
SET	80000 GAL
CLOCK	NEXT <input type="button" value="▲"/> <input type="button" value="▼"/> REGEN

Step 8F(B) – Service Alarm Volume: Use ▼ or ▲ to set the volume of water treated between service alarms. This display will only appear if Step 8F is set to *GALLONS* or *BOTH*.

Press NEXT to go to Step 8F(C) or Step 8F(D). Press REGEN to return to the previous step.

STEP 8F(C)

SCHEDULE SERVICE	
IN	1.25 YR
CLOCK	NEXT <input type="button" value="▲"/> <input type="button" value="▼"/> REGEN

Step 8F(C) – Status Display (Time): Time remaining until service alarm generation. This display will only appear if Step 8F is set to *TIME* or *BOTH*. To reset this value to the value set in Step 8F(A), press ▼ and ▲ simultaneously for 3 seconds.

Press NEXT to go to Step 8F(D) or to exit OEM Filter System Setup. Press REGEN to return to previous step.

STEP 8F(D)

SCHEDULE SERVICE	
IN	80000 GAL
CLOCK	NEXT <input type="button" value="▲"/> <input type="button" value="▼"/> REGEN

Step 8F(D) – Status Display Volume: Capacity remaining until service alarm generation. This display will only appear if Step 8F is set to *GALLONS* or *BOTH*. To reset this value to the value set in Step 8F(B), press ▼ and ▲ simultaneously for 3 seconds.

Press NEXT to exit OEM Filter System Setup. Press REGEN to return to previous step.

Setting Options Table

SYSTEM TYPE	REGENERATION OPTION	REGENERATION TYPE	DAY OVERRIDE	OPERATION DESCRIPTION
Filtering	20 – 1,500,000 Gallons	Normal	1 – 28 days	Regeneration occurs at the next regeneration time when volume capacity reaches 0, or the specified number of days is reached, whichever comes first.
Filtering	20 – 1,500,000 Gallons	Normal	OFF	Regeneration occurs at the next regeneration time when volume capacity reaches 0.
Filtering	OFF	Normal	1 – 28 days	Time Clock operation. Regeneration occurs at the next regeneration time the specified number of days is reached.
Filtering	20 – 1,500,000 Gallons	On 0	OFF	Regeneration occurs immediately when volume capacity reaches 0.
Filtering	20 – 1,500,000 Gallons	Normal + On 0	1 – 28 days	Regeneration occurs at the next regeneration time the specified number of days is reached or regeneration occurs after 10 minutes of no water usage when volume capacity reaches 0.

Installer Display Settings

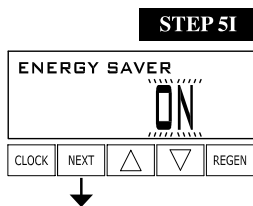
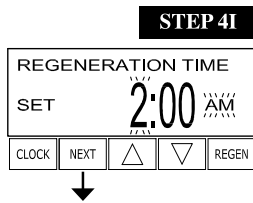
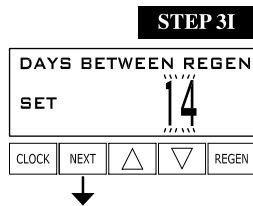
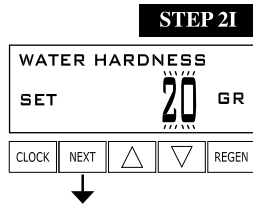
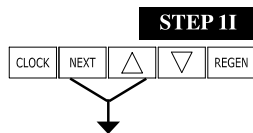

RETURN TO NORMAL MODE

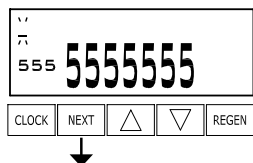

Step 1I – Press NEXT and ▲ simultaneously for 3 seconds.

Step 2I – Hardness: Use ▼ or ▲ to set the amount of hardness in grains of hardness as calcium carbonate per gallon (Range: 1 – 150 grains). The grains per gallon can be increased if soluble iron needs to be reduced. This display will not appear if Volume Capacity is set to anything other than AUTO.

Press NEXT to go to Step 3I. Press REGEN to return to the previous step.

Step 3I – Day Override: When Volume Capacity is set to OFF, sets the number of days between regenerations. When Volume Capacity is set to AUTO or to a number, sets the maximum number of days between regenerations. Use ▼ or ▲ to select one of the following options:

- A number (1 – 28): Regeneration initiation will be called for every set number of days even if sufficient volume of water was not used to call for a regeneration. BOTH: Activates the service alarm after a set duration of time and after a set volume of water is treated, whichever comes first.
- OFF: Regeneration initiation is based solely on volume used. Press NEXT to go to Step 9S(A) or Step 10S. Press REGEN to return to previous step.

Press NEXT to go to Step 4I. Press REGEN to return to previous step.

Step 4I – Next Regeneration Time: Use ▼ or ▲ to set the hour of day for regeneration. a.m./p.m. toggles after 12. The default time is 2:00 a.m. This display will not appear if Regeneration Time Option is set to IMMEDIATE REGENERATION. Press NEXT to set the minutes.

Once the minutes are set, press NEXT to go to Step 5I. Press REGEN to return to previous step.

Step 5I – Energy Saver: Use ▼ or ▲ to select one of the following options:

- ON: Display backlight will turn off after 5 minutes of inactivity and turn on when a button is pushed.
- OFF: Display backlight is always on.

Press NEXT to exit Installer Display Settings or press and hold CLOCK and ▲ to go to Step 6I. Press REGEN to return to previous step

CONTACT SCREENS

Step 6I – Service Alarm Phone Number: Use ▼ or ▲ to set first digit of phone number. Press NEXT to advance to the next digit. Press REGEN to return to the previous digit.

Once all digits are set, press NEXT to go to Step 7I.

Step 7I – Service Alarm Banner Text: Cursor will appear above the first number in upper left corner on the display. Use ▼ or ▲ to set the first character of the banner text. Press NEXT to advance to the next character. Press REGEN to return to the previous character. There is a maximum of 55 characters in the banner text.

Once all characters are set, press NEXT until system exits the Installer Display Settings.

User Display Settings

General Operation

When the system is operating, one of several displays may be shown. The displays normally rotate; however, pressing NEXT will pause on the selected display for 5 minutes. Press NEXT to alternate between the displays. One of the displays is always the current time of day. Days Remaining is the number of days left before the system goes through a regeneration cycle. Gallons Remaining is the capacity that will be treated before the system goes through a regeneration cycle. Press ▼ while on the Gallons Remaining display to decrease the capacity remaining in 10 gallon increments and also increase the volume used in Diagnostics Steps 3D, 4D, and 5D and Valve History Step 4VH.

Flow Rate shows the current rate treated water is flowing through the system. If the dP switch is closed, the display will show REGENERATION DP or REGENERATION HOLD.

To clear the Service Call reminder, press ▼ and ▲ simultaneously while the number and banner text screen is displayed.

If the system has called for a regeneration that will occur at the preset time of regeneration, the words REGEN TODAY will alternate with the header on the display.

If a water meter is installed, the flow indicator flashes on the display when water is being treated (i.e., water is flowing through the system).

DELAYED RINSE+FILL PENDING is displayed whenever a zero-capacity tank has transferred to an off-line state and is currently waiting to initiate the second portion of a regeneration cycle. Viewed only when Delayed Rinse and Fill is set to ON.

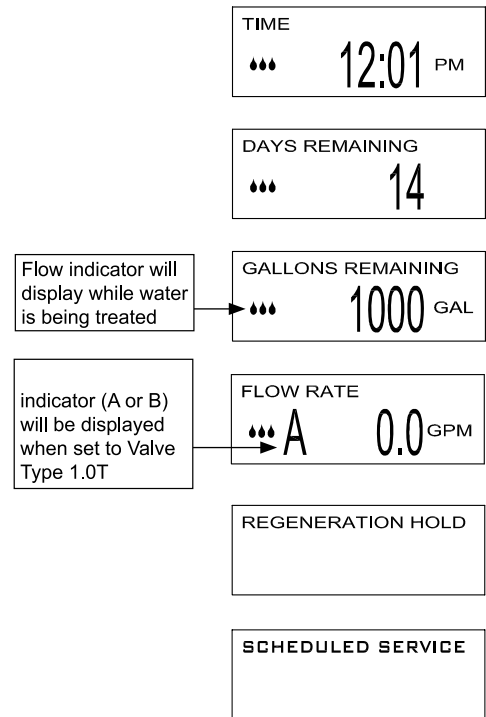

Additional Displays

REGEN PENDING is displayed in alternator systems whenever a unit is waiting to initiate the first cycle step of regeneration. The name of an active MAV will also be indicated in this display.

STAND BY is displayed in alternator systems when a valve is in standby mode. The name of an active MAV will also be indicated in this display.

DELAYED RINSE+FILL PENDING is displayed whenever a zero-capacity tank has transferred to an off-line state and is currently waiting to initiate the second portion of a regeneration cycle. Viewed only when Delayed Rinse and Fill is set to ON.



Regeneration Mode

Typically, a system is set to regenerate at a time of low water usage. An example of a time with low water usage is when a household is asleep. If there is a demand for water when the system is regenerating, untreated water will be used.

When the system begins to regenerate, the display will change to include information about the step of the regeneration process and the time remaining for that step to be completed. The system runs through the steps automatically and will reset itself to provide treated water when the regeneration has been completed.

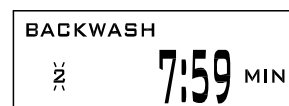

Installer Display Settings

Manual Regeneration

Sometimes, there is a need to regenerate the system sooner than when the system calls for it, usually referred to as manual regeneration. There may be a period of heavy water usage because of guests or a heavy laundry day.

To initiate a manual regeneration at the preset delayed regeneration time when the Regeneration Time Option is set to DELAYED REGENERATION or DELAY + IMMEDIATE REGENERATION, **press and release** REGEN. The words REGEN TODAY will flash on the display to indicate that the system will regenerate at the preset delayed regeneration time. Press REGEN again to cancel the request.

Note: If the Regeneration Time Option is set to IMMEDIATE REGENERATION, there is no set delayed regeneration time, so REGEN TODAY will not activate if REGEN is pressed.

To initiate a manual regeneration immediately, press and hold the REGEN button for 3 seconds. The system will begin to regenerate immediately. The request cannot be canceled.

Note: For softeners, if brine tank does not contain salt, fill with salt and wait at least 2 hours before regenerating.

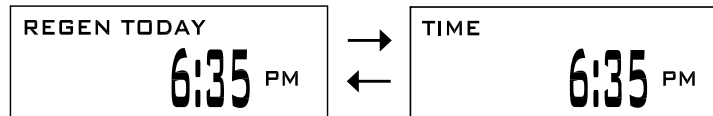

Set Time of Day

The user can also set the time of day. Time of day should only need to be set if the battery has been depleted because of extended power outages or when daylight saving time begins or ends. If an extended power outage occurs, the time of day will flash, which indicates the time of day should be reset and the non-rechargeable battery replaced.

Step 1U – Press CLOCK.

Step 2U – Current Time (hour): Use ▼ or ▲ to set the hour of the day. a.m./p.m. toggles after 12. Press NEXT to go to Step 3U.

Step 3U – Current Time (minutes): Use ▼ or ▲ to set the minutes of the day.

Press NEXT to exit Set Time of Day. Press REGEN to return to previous step.

Power Loss:

If the power goes out the system will keep time until the battery is depleted. If an extended power outage occurs, the time of day will flash on and off which indicates the time of day should be reset and the non rechargeable battery replaced. The system will remember the rest.

Error Message:

If the word ERROR and a number are displayed, contact the OEM for help. This indicates that the valve was not able to function properly. If the number and banner text in the Contact Screens has been edited, the 2 displays below will alternate.

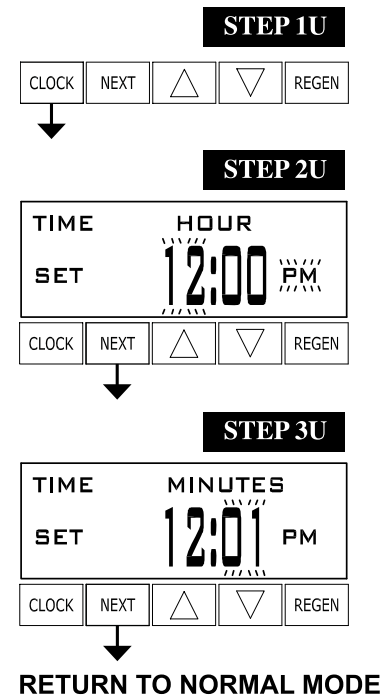

Replacing the Media

1. Mark the location of the mineral tanks on the floor incase they need to be moved once all water, media and gravel has been removed. This will help with realignment of the plumbing after media replacement. DO NOT attempt to move a mineral tank that contains media and or water.
2. Open the bypass valve.
3. Close the inlet and outlet isolation valves for the mineral tank needing media replacement
4. Locate "Manual Regeneration" on page 21 for the controller.
5. Follow the steps to place the system in the backwash position. This relieves any pressure inside the mineral tank. Once the system cycles into the backwash position, unplug the control valve from the power outlet to keep the system in the backwash position.
6. Disconnect the inlet, outlet, and drain union plumbing fittings. Then, if necessary for the removal of the control valve from the mineral tank, remove the remaining plumbing from the inlet, outlet and drain ports of the control valve.
7. Unplug the power cord.
8. Remove the control valve from the mineral tank by turning the control valve counter-clockwise when viewed from above. Keeping a firm grip on the control valve, continue to rotate until it can be lifted off of the top of the mineral tank. Store the control valve in a safe location.
9. Note the top of the distributor tube. It must be flush with the top of the tank. If it is above the top of the tank by more than 1/2" the distributor tube may have become disconnected from the distributor screen in the bottom of the mineral and must be reconnected.
10. Obtain a length of 3/4" sch. 40 PVC that is the same height as the mineral tank and a length of 1" clear braided poly-vinyl hose. The hose must be long enough to reach the nearest floor drain. (Both of these can be acquired at a local hardware store).
11. Insert one end of the pipe inside the hose and the other end of the pipe into the top of the mineral tank and down into the media. Put the other end of the hose inside a water permeable bag and locate the bag over the floor drain.
12. Insert a garden hose into the bag side of the poly-vinyl hose to fill the hose and PVC pipe with water. Air will bubble out of the tank. Once all the air is out of the hose and pipe, remove the garden hose from the polyvinyl hose to establish a siphon. The media can then be siphoned into the bag. Use the garden hose to maintain a full water level in the mineral tank to. The bag end of the poly-vinyl hose must remain lower in elevation then the end of the PVC pipe in the mineral tank to maintain the siphon. The bag will retain the media while the water flows down the drain. Use caution not to allow media to enter the floor drain.
13. Continue to siphon media until it is completely evacuated from the mineral tank. Gravel will clogged the siphon hose and, if it must be removed due to fouling, or to repair or replace a damaged distributor tube and screen, must be evacuated by other means.
14. If replacing gravel, inspect lower distributor screens for damage and replace if necessary.
15. To add new media and reconnect control valve to mineral tank follow General Installation step G located on page 9 of this manual.
16. Reconnect inlet, outlet, and drain plumbing to the control valve and tighten the plumbing union fittings on each of these plumbing lines.
17. Open the inlet isolation valve slightly until water can be heard flowing through the isolation valve and allow the mineral tank to fill with water. Air will come out of the drain line until the mineral tank is full of water. Once full, close the inlet isolation valve and let the tank sit for 24 hours to allow the media to thoroughly soak.
18. After 24 hours of pre-soaking, open the inlet valve fully and allow water to flow to the drain, initiating the initial backwash to flush the media bed of any color or fines. Continue flushing the media bed until the water at the drain runs clear.
19. Plug the system back in to the power outlet so that it will return to the service position.
20. Fully open inlet and outlet isolation valves and close bypass valve.
21. Check for leaks and repair as required.
22. Open hot and cold side of a treated water faucet to flush any air from the plumbing system.

If this is a multi-tank system replace media in each mineral tank according to this media replacement procedure.

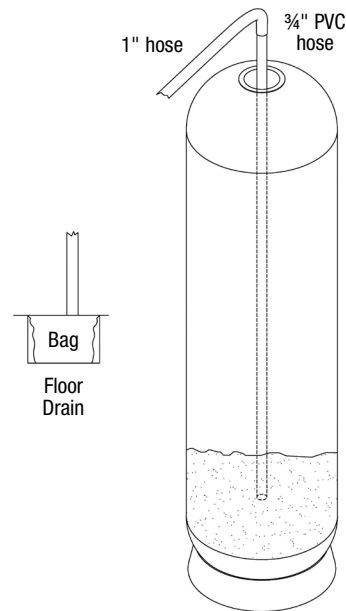

System Components Described

Components:

The control valve consists of the following components:

1. Drive Assembly
2. Drive Cap Assembly, Main Piston and Regenerant Piston
3. Spacer Stack Assembly
4. Injector Cap, Screen, Injector Plug and Injector
5. Refill Flow Control Assembly or Refill Port Plug
6. Drain Line Flow Control and Fitting Assembly
7. Water Meter or Meter Plug
8. Installation Fitting Assemblies
9. Bypass Valve (optional)

Drive Assembly

The drive assembly consists of the following parts:

- Drive Bracket
- Printed Circuit (PC) Board
- Motor
- Drive Gears
- Drive Gear Cover

The drive bracket holds the PC board, the motor, the drive gears and the drive gear cover in place.

The PC board receives and retains information, displays the information, determines when to regenerate and initiates regeneration. The display shows different types of information in the initial system set up (for softeners or filters), installer displays/settings, diagnostics, and valve history or user displays/settings.

The PC board's two-prong jack connects wires to the direct current (DC) motor. The motor is held in place on the drive bracket by a spring-loaded clip and a small bulge in the plastic, which fits in one of the slots on the motor housing. The motor turns drive gears that drive the piston to cycle positions for backwashing, regeneration, rinsing, refill or service. The motor is fully reversible (turns both ways) and changes direction of rotation to change the direction of piston motion. The motor is easily replaced if necessary.

There are three drive gears held in place by the drive gear cover. All three drive gears are the same size. A reflective coating is applied to the gears. As the center drive gear turns a light shines on the coating and a light sensing diode determines if a light pulse was returned. The PC board counts the pulses and determines when to stop driving the motor.

Drive Cap Assembly

Main Piston and Regenerant Piston

The drive gears turn the main gear of the drive cap assembly, which moves the piston. The screw-driven, horizontally moving piston stops at specific positions to direct the flow of water to backwash, regenerate, rinse or refill. The PC board determines the position of the piston by counting pulses produced when the piston is moved. An optical sensor looking at one of the reduction drive gears generates these pulses. Each cycle position is defined by a number of pulses. The counter is zeroed each time the valve goes to the service position. The PC board finds the service position by noting the increase in current delivered to the motor when the mechanical stop at the service position is reached. This method of controlling piston position allows for greater flexibility and requires no switches or cams.

One of two main pistons is always used:

1. The down flow piston which is used when the control valve is used as a down flow softener, regenerating filter or non regenerating filter:
2. The up flow piston, which is used when the control valve is used as an up flow softener.

If the control valve is used as a softener or a regenerating filter, a regenerant piston must be attached to the main piston. If the control valve is to be used on system that does not require a regenerant to be added the regenerant piston must be removed.

Spacer Stack Assembly

The spacer stack assembly provides the necessary flow passage for water during the different cycles. The all-plastic spacer stack assembly (patent pending) is a one-piece design, which allows the stack to be removed using your fingers.

The exterior of the stack is sealed against the body bore with self-lubricating EPDM O-rings while the interior surface is sealed against the piston using slippery self cleaning directional (one way) silicone lip seals. The lip seals are red or clear in color and have a special slippery coating so that the piston does not need to be coated or lubricated.

Injector

The screen, injector and/or injector plug(s) are installed under the injector cap in an easy to access location on top of the valve. The injector cap contains four slots so no water accumulates in the cap. The injector cap is designed to be hand tightened.

Under the injector cap there is an easy to clean removable screen to prevent fouling of the injector. There are two holes under the injector cap labeled "DN" and "UP". The holes will be filled with a plug or an injector.

The plug (68104901) prevents water from traveling a certain pathway. The injector lets water pass through the pathway. The self-priming injector increases the velocity of the water, creating a zone of negative pressure that draws in the concentrated liquid regenerant, such as sodium chloride (brine), potassium permanganate, sodium hydroxide, hydrochloric acid, etc. The regenerant blends with the stream of water, which passes through the media to regenerate the bed.

The injector provides a consistent regenerant/water mixture ratio over the entire operating pressure range of the control valve. The injector provides good performance in a variety of applications, which may involve elevated drain lines and long regenerant draw lengths. Injectors are chosen by knowing the type, amount, and regenerant flow rate for a particular type of media. The color coded injectors give different regenerant draw, slow rinse and total flow rates over the pressure range. See Table below for color codes.

Injector Order Information

PART #	COLOR	TANK DIA.
68104893	RED	9"
68104894	WHITE	10"
68104895	BLUE	12"

System Components Described

Refill Flow Control Assembly

The refill flow control assembly consists of a refill flow elbow, refill flow control retainer assembly, refill flow control, poly tube insert and nut assembly. The refill flow control retainer fits in the refill elbow. The refill flow control retainer houses the refill flow control, which controls the flow rate when the regenerant tank is being refilled. The refill flow control is a flexible washer-like part with a small orifice and a precision molded contour that delivers a steady 0.5 gpm regenerant tank refill rate at varying inlet pressures. Refill is accomplished with treated water.

The refill flow control assembly is installed in an easy to access refill elbow located on top of the control valve. The refill flow control assembly is attached to the control valve with a locking clip. The locking clip allows the elbow to rotate 270 degrees so the outlet can be orientated towards the regenerant tank.

Drain Line Flow Control/Fitting

The drain line flow control assembly includes a drain line flow control and a fitting. The drain line flow control allows proper media bed expansion by regulating the flow rate to the drain. The drain line flow control is a flexible washer-like part with an orifice and a precision molded contour. The flow rates are within $\pm 10\%$ over the pressure range of 10 psi to 125 psi. The flexible washer-like parts are identified with three numbers, which correspond to the flow rate in gallons per minute. See Table below.

The drain line flow control and fitting are located on top of the control valve and replaceable without the use of special tools.

Drain Line Flow Control (3/4" Fitting)

PART #	NUMBER ON BACKWASH FLOW RATE	
	Fitting	GPM
68104946	75	7.5
68104948	100	10
68104963	150	15

The drain line flow control can be installed in the standard 1/4" drain line elbow, which accommodates 5/8" poly tube or 3/4" NPT drain line connections. The optional nut and poly tube insert for the 3/4" drain line elbow is designed for use with flexible poly tube only. The 3/4" drain line elbow can be rotated 180 degrees so the outlet can be orientated to the nearest drain. The same retainer is used for all drain line flow controls for the 3/4" fitting.

Water Meter Or Meter Plug

The water meter is installed on the outlet side of the control valve. The water meter uses a turbine to total gallons of treated water. The turbine rotates with the flow of water and reports its rate of rotation through Hall-effect 8 circuitry to the printed circuit (PC) board. This rotation permits the PC board to record the total volume of treated water and the flow rate. The small centrally located magnet is shielded from water, which reduces substantially iron-fouling problems with the turbine. The turbine is accurate to within $\pm 5\%$ over a wide operating flow rate range (0.25 gpm up to control valve maximums) and has a very low pressure drop. Water used for regeneration is not metered. If the control valve is set to prefill the regenerant, the water used between the prefill cycle up to the start of the regeneration cycle is metered. If the control valve is in regeneration mode (e.g. a backwash cycle) and there is a water demand, that water usage is not metered.

When facing the front of the control valve, the water meter is positioned on the left-hand side of the control valve. Allow sufficient clearance to clean and repair the water meter with out disconnecting the plumbing or disassembling any other parts of the control valve.

A unique feature of this control valve is the ability to display actual water usage for the last 63 days. The values are initially stored as “_” because it is unknown. As days pass values are stored as “O” for no flow or the actual number of gallons. The counting of the gallons starts at the regeneration time. If no regeneration time can be set (i.e. when the valve is set for immediate regeneration) the counting of gallons starts at 12 a.m. Day 1 is yesterday, day 2 the day before yesterday, etc. As new values are added the oldest history disappears.

Another unique feature is that the valve automatically calculates a reserve capacity when set up as a softener with “Gallons Capacity” set to “AUTO”. The reserve capacity for a given day of the week is the middle value stored for the last three non-trivial water usages (i.e. less than 20 gallons day) in seven-day intervals which is then adjusted either upward or downward depending upon the difference between today's water usage and the estimated reserve capacity.

System Components Described

Installation Fitting Assemblies

The installation fittings are used to connect the optional bypass or the control to the plumbing system. There are five installation-fitting assemblies available:

1. 1 1/4" & 1 1/2" PVC Solvent (Included)
2. 1" NPT elbow
3. 3/4" & 1" PVC solvent weld elbow fitting
4. 1" straight brass sweat fitting
5. 3/4" straight brass fitting

Both elbow fittings have a unique drill out feature to allow a 1/4" NPT connection to the inlet and/or outlet which can be used for a RO feed, test ports, pressure tap ports, etc.

The installation fitting assemblies are sold in pairs and consist of two fittings, two nuts, two split rings and two O-rings. The installation fitting assemblies and the bypass valve are sold separately from the control valve.

Figure 13:

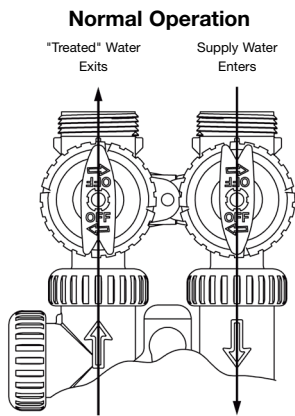

Figure 14:

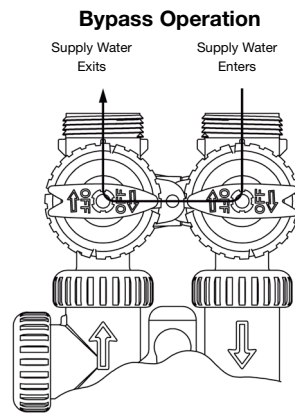

Figure 15:

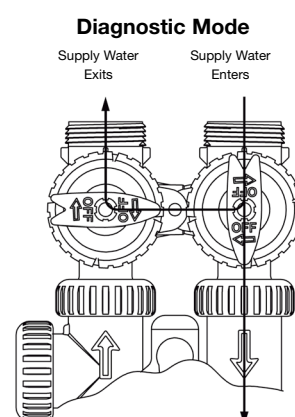
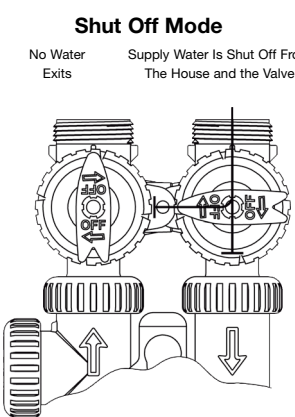

Figure 16:



Bypass Valve

The bypass valve is typically used to isolate the control valve from the plumbing system's water pressure in order to perform control valve repairs or maintenance. The W100SM bypass valve is particularly unique in the water treatment industry due to its versatility and state of the art design features. The 1" full flow bypass valve incorporates four positions including a diagnostic position that allows service personal to work on a pressurized system while still providing untreated bypass water to the facility or residence. Its completely non-metallic, all plastic design allows for easy access and serviceability without the need for tools.

The bypass body and rotors are glass filled Noryl and the nuts and caps are glass filled polypropylene. All seals are self-lubricating EPDM to help prevent valve seizing after long periods of non-use. Internal O-rings can easily be replaced if service is required.

The bypass consists of two interchangeable plug valves that are operated independently by red arrow shaped handles. The handles identify the flow direction of the water. The plug valves enable the bypass valve to operate in four positions.

1. Normal Operation Position: The inlet and outlet handles point in the direction of flow indicated by the engraved arrows on the control valve. Water flows through the control valve during normal operation and this position also allows the control valve to isolate the media bed during the regeneration cycle. (See Figure 13)
2. Bypass Position: The inlet and outlet handles point to the center of the bypass, the control valve is isolated from the water pressure contained in the plumbing system. Untreated water is supplied to the plumbing system. (See Figure 14)
3. Diagnostic Position: The inlet handle points in the direction of flow and the outlet handle points to the center of bypass valve, system water pressure is allowed to the control valve and the plumbing system while not allowing water to exit from the control valve to the plumbing. (See Figure 15)
4. Shut Off Position: The inlet handle points to the center of the bypass valve and the outlet handle points in the direction of flow, the water is shut off to the plumbing systems. If water is available on the outlet side of the softener it is an indication of water bypass around the system (i.e. a plumbing connection somewhere in the building bypasses the system). (See Figure 16)

* Some semiconductor materials exhibit a phenomenon in the presence of a magnetic field that is adaptable to sensing devices. When a current is passed through one pair of wires attached to a semiconductor, another pair of wires properly attached and oriented with respect to the semiconductor will develop a voltage proportional to the magnetic field present and the current in the other pair of wires. Holding the exiting current constant and moving a permanent magnet near the semiconductor produces a voltage output proportional to the movement of the magnet. Hall-effect devices provide a high-speed response, excellent temperature stability and no physical contact.

Drive Assembly

Remove the valve cover to access the drive assembly.

Disconnect the power source plug (black wire) from the PC board prior to disconnecting the motor or water meter plugs from the PC board. The motor plug connects to the two-pin jack on the left-hand side of the PC board. The power source plug connects to the four-pin jack. The four-pin jack is between the two-pin and three-pin jacks. The water meter plug (gray wire) connects to the three-pin jack.

The PC board can be removed separately from the drive bracket but it is not recommended. Do not attempt to remove the display panel from the PC board. Handle the board by the edges. To remove the PC board from the drive bracket, unplug the power, water meter and motor plugs from the PC board. Lift the middle latch along the top of the drive bracket while pulling outward on the top of the PC board. The drive bracket has two plastic pins that fit into the holes on the lower edge of the PC board. Once the PC board is tilted about 45° from the drive bracket it can be lifted off of these pins. To reinstall the PC board, position the lower edge of the PC board so that the holes in the PC board line up with the plastic pins. Push the top of the PC board towards the valve until it snaps under the middle latch, weave the power and water meter wires into the holders and reconnect the motor water meter and power plugs.

The drive bracket must be removed to access the drive cap assembly and pistons or the drive gear cover. It is not necessary to remove the PC board from the drive bracket to remove the drive bracket. To remove the drive bracket, start by removing the plugs for the power source and the water meter. Unweave the wires from the side holders. Two tabs on the top of the drive back plate hold the drive bracket in place. Simultaneously lift the two tabs and gently ease the top of the drive bracket towards your body. The lower edge of the drive bracket has two notches that rest on the drive back plate. Lift up and outward on the drive bracket to disengage the notches.

To reassemble seat the bottom of the drive bracket so the notches are engaged at the bottom of the drive back plate. Push the top of the drive bracket towards the two latches. The drive bracket may have to be lifted slightly to let the threaded piston rod pass through the hole in the drive bracket. Maintain a slight engaging force on top of the drive bracket while deflecting the bracket slightly to the left by pressing on the side of the upper right corner. This helps the drive gears mesh with the drive cap assembly. The drive bracket is properly seated when it snaps under the latches on the drive back plate.

If resistance is felt before latching, then notches are not fully engaged, the piston rod is not in hole, the wires are jammed between the drive bracket and drive back plate, or the gear is not engaging the drive cap assembly.

To inspect drive gears, the drive gear cover needs to be removed. The drive gear cover is held in place on the drive bracket by three clips. The largest of the three clips is always orientated to the bottom of the drive bracket. Before trying to remove the drive gear cover, the drive bracket must be removed from the drive back plate. The drive gear cover can be removed from the drive bracket without removing the motor or the PC board. Simultaneously, push in and down on the large clip at the bottom and the clip on the left-hand side of the drive bracket behind the PC board. Keep your other fingers behind the drive gear cover so the drive gears do not drop on the ground. Replace broken or damaged drive gears. Do not lubricate any of the gears. Avoid getting any foreign matter on the reflective coating because dirt or oils may interfere with pulse counting.

The drive gear cover only fits on one way, with the large clip orientated towards the bottom. If all three clips are outside of the gear shroud on the drive bracket the drive gear cover slips easily into place.

The drive bracket does not need to be removed from the drive plate if the motor needs to be removed. To remove the motor, disconnect the power and motor plugs from the jacks on the PC board. Move the spring clip loop to the right and hold. Rotate the motor at least a 1/4 turn in either direction before gently pulling on the wire connectors to remove the motor. Pulling directly on the wires without rotating the motor may break the wires off the motor.

Replace the motor if necessary. Do not lubricate the motor or the gears. When reinstalling the motor gently turn the motor while inserting so that the gear on the motor meshes with the gears under the drive gear cover and the small plastic bulge engages one of the slots on the motor housing. Reconnect the motor plug to the two-pronged jack on the lower left-hand side of the PC board. If motor will not easily engage with drive gear when reinstalling, lift and slightly rotate motor before reinserting.

Replace the valve cover. After completing any valve maintenance, press and hold NEXT and REGEN buttons for 3 seconds or unplug power source jack (black wire) and plug back in. This resets the electronics and establishes the service piston position. The display should flash all wording, then flash the software version (e.g. 154) and then reset the valve to the service position.

Service Instructions

Drive Cap Assembly, Main Piston and Regenerant Piston

The drive assembly must be removed to access the drive cap assembly. The drive cap assembly must be removed to access the piston(s). The drive cap assembly is threaded into the control valve body and seals with an O-ring. To remove the drive cap assembly, use the special plastic wrench or insert a 1/4" to 1" flat bladed screwdriver into one of the slots around the top 2" of the drive cap assembly so it engages the notches molded into the drive back plate around the top 2" of the piston cavity. See Figure 17. The notches are visible through the holes. Lever the screwdriver so the drive cap assembly turns counter clockwise. Once loosened unscrew the drive cap assembly by hand and pull straight out.

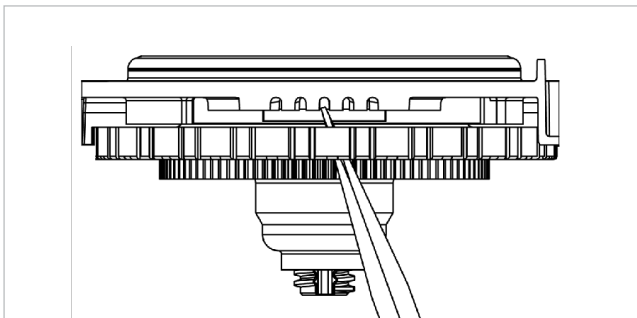

Figure 17: To remove drive cap

The drive cap assembly contains the drive cap, the main drive gear, drive cap spline, piston rod and various other parts that should not be disassembled in the field. The only replaceable part on the drive cap assembly is the O-ring. Attached to the drive cap assembly is the main piston (downflow or upflow) and if a regenerant is used, a regenerant piston.

The regenerant piston (the small diameter one behind the main piston) is removed from the main piston by unsnapping it from its latch. Chemically clean in dilute sodium bisulfite or vinegar or replace the regenerant piston if needed. To remove the main downflow or upflow piston fully extend the piston rod and then unsnap the main piston from its latch by pressing on the side with the number. Chemically clean in dilute sodium bisulfite or vinegar or replace the main piston.

Reattach the main piston to the drive cap assembly. Reattach the regenerant piston (if needed) to the main piston. Do not lubricate the piston rod, main piston or regenerant piston. Lubricant will adversely affect the red or clear lip seals. Reinsert the drive cap assembly and piston into the spacer stack assembly and hand tighten the drive cap assembly. Continue to tighten the drive cap assembly using a screwdriver as a ratchet until the black O-ring on the spacer stack assembly is no longer visible through the drain port. Excessive force can break the notches molded into the drive back plate. Make certain that the main drive gear still turns freely. The exact position of the piston is not important as long as the main drive gear turns freely.

Reattach the drive assembly to the control valve and connect all plugs. After completing any valve maintenance, press and hold NEXT and REGEN buttons for 3 seconds or unplug power source jack (black wire) and plug back in. This resets the electronics and establishes the service piston position. The display should flash all wording, then flash the software version (e.g. 154) and then reset the valve to the service position.

Spacer Stack Assembly

To access the spacer stack assembly remove the drive assembly, drive cap assembly and piston. The spacer stack assembly can be removed easily without tools by using thumb and forefinger. Inspect the black O-rings and red or clear lip seals for wear or damage. Replace the entire stack if necessary. The spacer stack assembly has been 100% tested at the factory to insure proper orientation of one-way seals. Do not disassemble the stack.

The spacer stack assembly may be chemically cleaned (dilute sodium bisulfite or vinegar) or wiped with a soft cloth.

The spacer stack assembly can be pushed in to the control valve body bore by hand. Since the spacer stack assembly can be compressed it is easier to use a blunt object (5/8" to 1-1/8" in diameter) to push the center of the assembly into the control valve body. The assembly is properly seated when at least four threads are exposed (approximately 5/8"). Do not force the spacer stack assembly in. The control valve body bore interior can be lubricated with silicone to allow for easy insertion of the entire stack. Do not use silicone or any other type of lubricant on the red or clear lip seals or the piston.

Reattach the drive cap assembly, and piston(s) and the drive assembly.

After completing any valve maintenance, press and hold NEXT and REGEN buttons for 3 seconds or unplug power source jack (black wire) and plug back in. This resets the electronics and establishes the service piston position. The display should flash all wording, then flash the software version (e.g. 154) and then reset the valve to the service position.

Injector Cap, Screen, Injector Plug and Injector

Unscrew the injector cap and lift off. Loosen cap with special plastic wrench or pliers if necessary. Attached to the injector cap injector cap is a screen. Remove the screen and clean if fouled.

The plug and/or injector can be pried out with a small screwdriver. The plug can be wiped clean. If the plug leaks replace the entire plug. The injector consists of a throat and a nozzle. Chemically clean the injector with vinegar or sodium bisulfite. The holes can be blown out with air. Both pieces have small diameter holes that control the flow rates of water to insure that the proper concentration of regenerant is used. Sharp objects, which can score the plastic, should not be used to clean the injector. Scoring the injector or increasing the diameter of the hole could change the operating parameters of the injector. Two holes are labeled DN and UP. Check for compliance with one of the following:

- For downflow systems, the appropriate size injector is located in the "DN" hole, a plug is in the "UP" hole and the piston is a combination of the downflow main piston and the regenerant piston.
- For upflow systems, the appropriate size injector is located in the "UP" hole, a plug is in the "DN" hole and the piston is a combination of the upflow main piston and the regenerant piston.
- For backwash only systems, a plug is in the "DN" hole and in the "UP" hole, and the piston only has a downflow main piston (the regenerant piston must be removed) and a plug is in the refill flow control position.

Push the plug(s) and/or injectors firmly in place, replace the screen and hand tighten the injector cap.

Service Instructions

Refill Flow Control Assembly or Refill Port Plug

To clean or replace the refill flow control, pull out the elbow locking clip and then pull straight up on the elbow. Replace the elbow-locking clip in the slot so that it is not misplaced. Twist to remove the white flow control retainer. The flow control can be removed by prying upward through the side slots of the retainer with a small blade flat screwdriver.

Chemically clean the flow control or the white flow control retainer using dilute sodium bisulfite or vinegar. Do not use a wire brush. If necessary, replace the flow control O-ring on the flow control retainer, or the O-ring on the elbow.

Reseat the flow control so the rounded end is visible in the flow control. Reseat the white flow control retainer by pushing the retainer into the elbow until the O-ring seats. Remove locking clip, push down on elbow to reseat and insert locking clip.

Do not use petroleum based lubricants, oils, or other unacceptable lubricants on O-rings. A silicon lubricant may be used on the O-ring on elbow or the white retainer.

Water Meter or Meter Plug

The water meter assembly is connected to the PC board by a wire. If the entire water meter assembly is to be replaced, remove the control valve cover and remove the power source and water meter plugs from the PC board. Unlatch the drive assembly and lean it forward. Unthread the water meter wire from the side of the drive assembly and through the drive back plate. To reinstall, rethread the water meter wire through the drive back plate and the side of the drive assembly. Reattach the drive assembly and the water meter and power plugs.

If no water meter wire is visible, then a plug is installed not a water meter.

The water meter wire does not need to be removed from the PC board if the water meter is only being inspected and cleaned.

To remove the water meter assembly, unscrew the meter cap on the left side of the control valve. Pliers may be used to unscrew the nut if necessary.

With the nut removed, a slot at the top of the water meter is visible. Twist a flat blade screwdriver in the slot between the control valve body and the meter. When the meter is part way out it is easy to remove the water meter from the housing. Once the water meter is removed from the control valve body, use your fingers to gently pull forward on the turbine to remove it from the shaft.

Do not use a wire brush to clean. Wipe with a clean cloth or chemically clean in dilute sodium bisulfite or vinegar. The turbine can be immersed in the chemical. Do not immerse electronics. If the turbine is scored or damaged or the bearings on the turbine are worn replace the turbine.

Do not lubricate the turbine shaft. The turbine shaft bearings are pre-lubricated. Do not use petroleum based lubricants, oils or other unacceptable lubricants on the O-ring. A silicon lubricant may be used on the black O-ring.

Snap the turbine on the shaft and reinsert the water meter into the side slot. Hand tighten the nut. Do not use a pipe wrench to tighten nut.

Bypass Valve

The working parts of the bypass valve are the rotor assemblies that are contained under the bypass valve caps. Before working on the rotors, make sure the system is depressurized. Turn the red arrow shaped handles towards the center of the bypass valve and back to the arrow direction several times to ensure rotor is turning freely.

The nuts and caps are designed to be unscrewed or tightened by hand. If necessary a pair of pliers can be used to unscrew the nut or cap. Do not use a pipe wrench to tighten or loosen nuts or caps. Do not place screwdriver in slots on caps and/or tap with a hammer. To access the rotor, unscrew the cap and lift the cap, rotor and handle out as one unit. Twisting the unit as you pull it out will help to remove it more easily. There are three O-rings: one under the rotor cap, one on the rotor stem and the rotor seal. Replace worn O-rings. Clean rotor. Reinstall rotor.

When reinstalling the red arrow handles be sure that:

1. O-rings on both rotors face to the right when being viewed from the front of the control valve when the handle pointers are lined up with the control valve body arrows.
2. Arrows point toward each other in the bypass position. Since the handles can be pulled off, they could be accidentally reinstalled 180° from their correct orientation. To install the red arrow handles correctly, keep the handles pointed in the same direction as the arrows engraved on the control valve body while tightening the bypass valve caps.

After completing, any valve maintenance, press and hold NEXT and REGEN buttons for 3 seconds or unplug power source jack (black wire) and plug back in. This resets the electronics and establishes the service piston position. The display should flash all wording then flash the software version (e.g. 154) and then reset the valve to the service position.

Drawings and Part Numbers

Mineral Tank

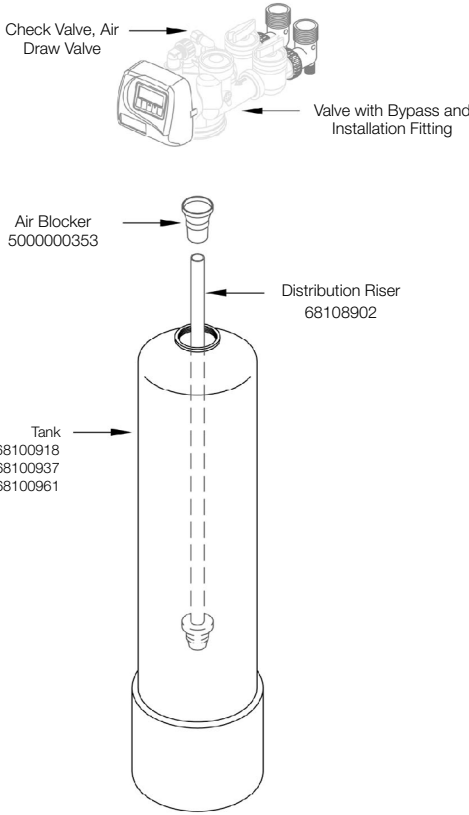

Front Cover and Drive Assembly

DRAWING #	ORDER #	DESCRIPTION	QTY
1	68111063	Locksmith Front Cover ASY	1
2	68104933	KC11V3107-01 Motor ASY	1
3		KC11V3002 Drive Bracket ASY w/ Motor	1
4	68111064	Locksmith Thru2 PCB Replace	1
5		KC12V3110 Drive Reducing Gear 12x36	3
6		KC12V3109 Drive Gear Cover	1
Not Shown	68104958	KC11V3186-06 Power Supply US 15VDC HOCP	1
	68111065	Locksmith Backplate	

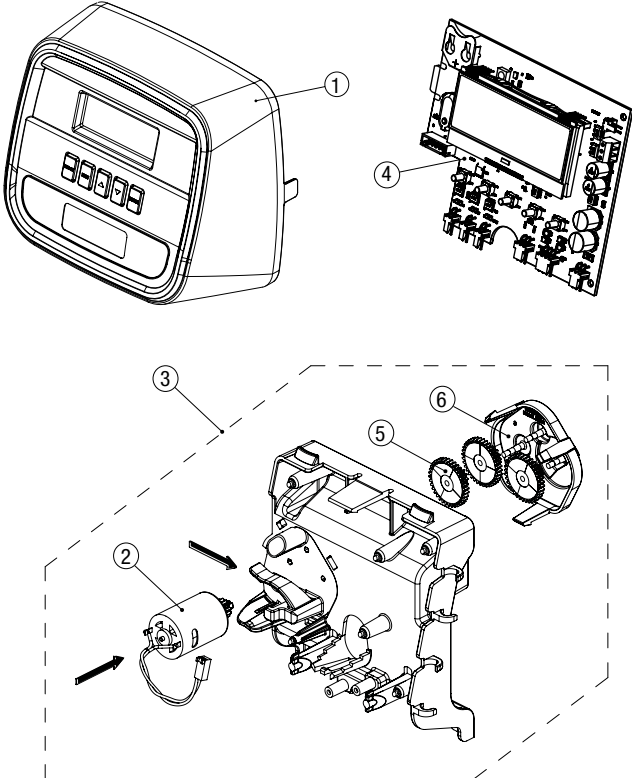

*Contact your dealer or installer for assistance with order numbers not listed.

Drawings and Part Numbers

Drive Cap Assembly, Downflow Piston, Upflow Piston, Regenerant Piston and Spacer Stack Assembly

DRAWING #	ORDER #	DESCRIPTION	QTY
1	68104870	KC12V3005 Spacer Stack Assembly	1
2	68105004	KC12V3004 Drive Cap ASY	1
3	68105006	KC12V3135 O-ring 228	1
4	68104911	KC12V3011 Piston Downflow ASY	1
5*	68104950	KC12V3174 Regenerant Piston	3
6	68105010	KC12V3180 O-ring 337	1

*The regenerant piston is not used in backwash only

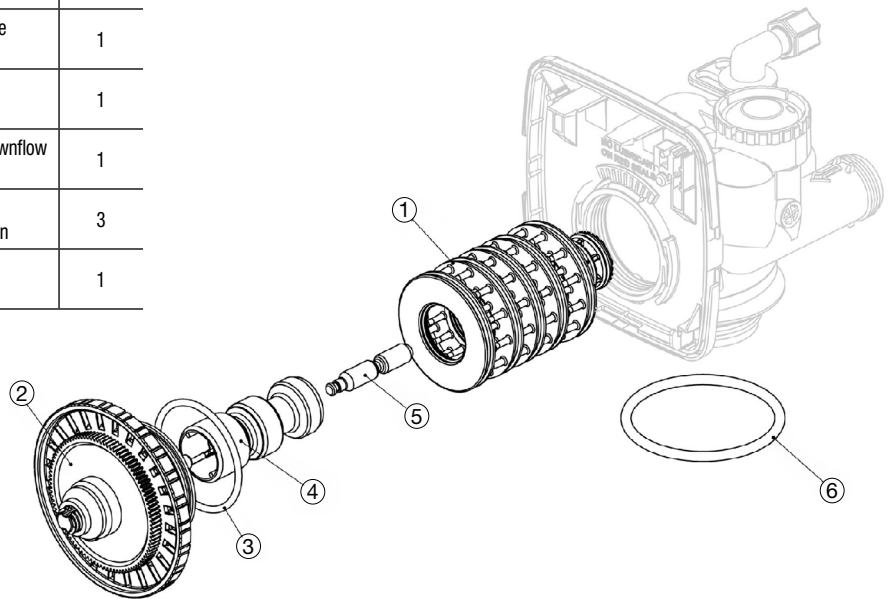

Injector Cap, Injector Screen, Injector, Plug and O-Ring

DRAWING #	ORDER #	DESCRIPTION	QTY
1		KC12V3176 Injector Cap	1
2	68105007	KC12V3152 O-ring 135	1
3		KC12V3177 Injector Screen	1
4	68104901	KC11V3010-1Z Injector ASY Z Plug	1
5	68104893	KC11V3010-1D Injector ASY D Red	1
	68104894	KC11V3010-1E Injector ASY E White	
	68104895	KC11V3010-1F Injector ASY F Blue	
Not Shown		KC12V3170 O-ring 011	*
Not Shown		KC12V3171 O-ring 013	*

*The injector plug and the injector each contain one 011 (lower) and 013 (upper) O-ring

Note: For upflow position, injector is located in the up hole and injector plug in the down hole. For a filter that only backwashes injector plugs are located in both holes.

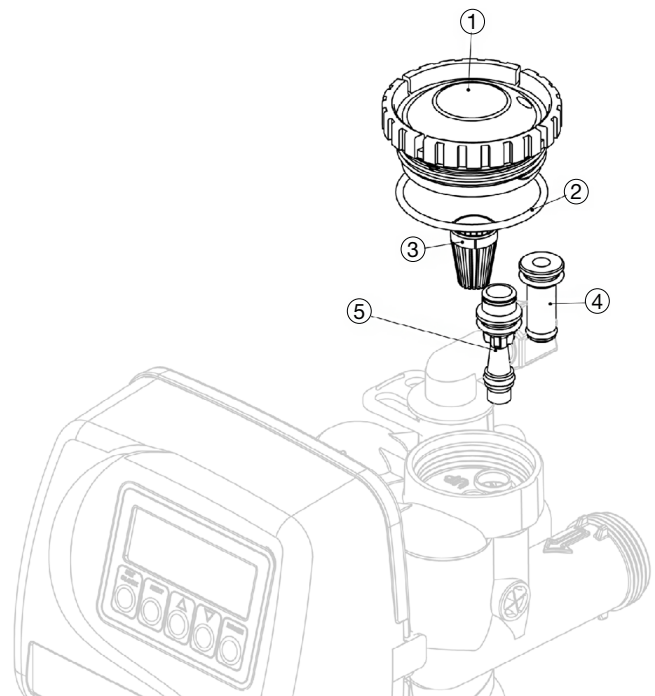

Drawings and Part Numbers

Drain Line - 3/4"

DRAWING #	ORDER #	DESCRIPTION	QTY
1	68104867	KC12H4615 Elbow Locking Clip	1
2	68105003	KC12PKP10T58 Polytube insert 5/8	Option
3	68105012	KC12V3192 Nut 3/4 Drain Elbow	Option
4	68105008	KC12V3158-01 Drain Elbow 3/4 Male ASY	1
5		KC12V3163 O-ring 019	1
6	68105009	KC12V3159-01 DLFC Retainer ASY	1
7*	68104946	KC11V3162-075 DLFC 7.5 gpm for 3/4"	
	68104948	KC11V3162-100 DLFC 10.0 gpm for 3/4"	

* Refer to specification table for BKW (Backwash) gpm flow rate for correct ordering code for your system.

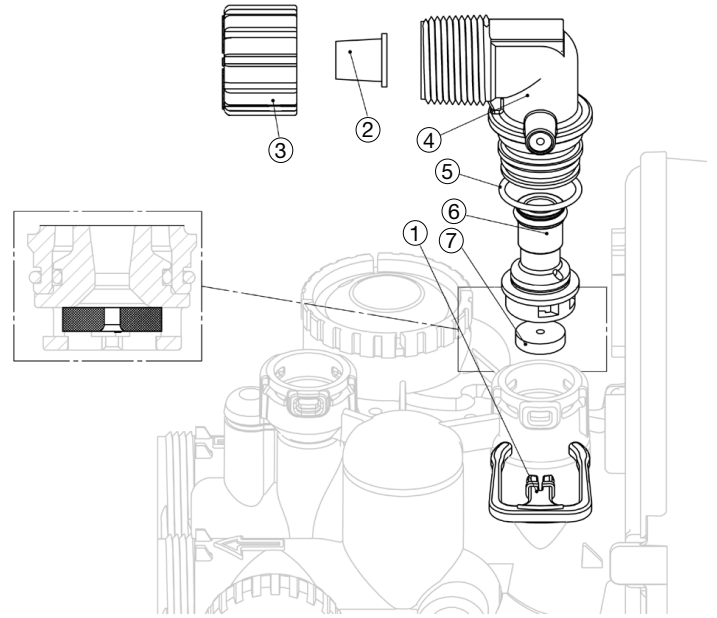

Drain Line - 1"

DRAWING #	ORDER #	DESCRIPTION	QTY
1	68104867	KC12H4615 Elbow Locking Clip	1
2	68104884	KC11V3008-02 Drain FTG 1" Straight	1
3	*	KC11V3166 Drain FTG Body 1"	1
4	*	KC11V3167 Drain FTG Adapter 1"	1
5	*	KC12V3163 O-ring 019	1
6	*	KC11V3150 Split Ring	1
7	*	KC11V3151 Nut 1" QC	1
8	*	KC11V3105 O-ring 215	1
9†	68104963	KC11V3190-150 DLFC 15.0 gpm for 1"	

* Can be ordered as a set under order # 68104884 (KC11V3008-02)
 † Refer to specification table for BKW (Backwash) gpm flow rate for correct ordering code for your system.

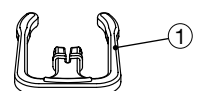
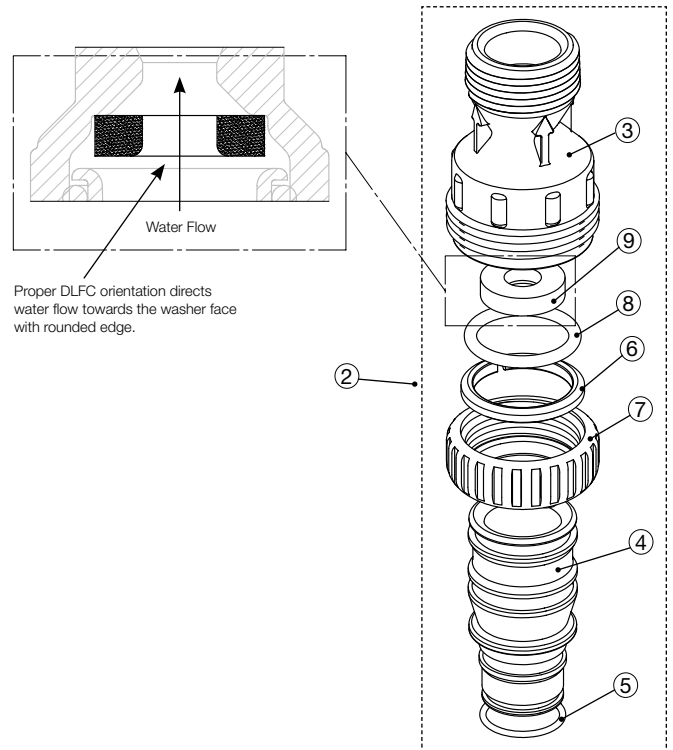

Drawings and Part Numbers

Air Draw Valve and Check Valve

DRAWING #	ORDER #	DESCRIPTION	QTY
1		V4144-01 3/8" Quick Connect Fitting	1
2	68111071	SUCTION LINE BALL .375 STRAINER	1
3	68103418	I8030 TUBING POLYETHYLENE .375OD LD BLK 100	0.003333
Not Shown	68111046	INLET CHECK VALVE	1
Not Shown	68111070	CHECK VALVE OV15/DN15	1

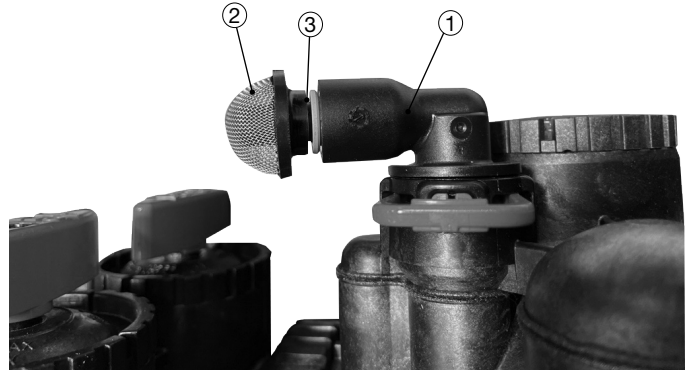

Water Meter And Meter Plug

ORDER #	DESCRIPTION	QTY
68104868	KC11V3003 Water Meter Assembly	1

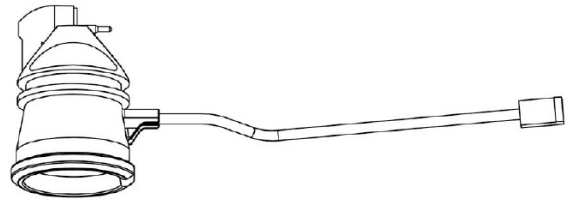

Drawings and Part Numbers

Installation Fitting Assemblies

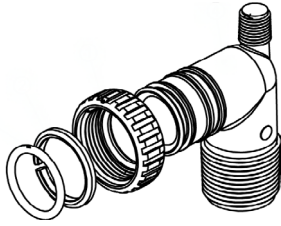

ORDER #	DESCRIPTION	QTY
68104872	KC11V3007 Fitting 1" PVC Male NPT Elbow	2

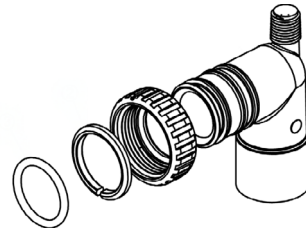

ORDER #	DESCRIPTION	QTY
68104873	KC11V3007-01 Fitting 3/4" & 1" PVC Socket 90 Elbow	2

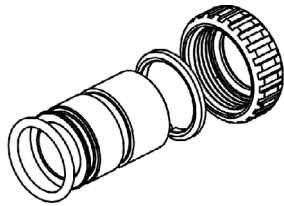

ORDER #	DESCRIPTION	QTY
68104874	KC11V3007-02 Fitting 1" Brass Sweat	2

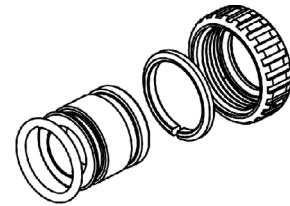

ORDER #	DESCRIPTION	QTY
68104875	KC11V3007-03 Fitting 3/4" Brass Sweat	2

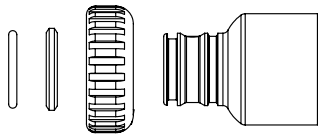

ORDER #	DESCRIPTION	QTY
68104878	KC11V3007-07 Fitting 1 1/4" & 1 1/2" PVC Solvent	2

Drawings and Part Numbers

ORDER #	DESCRIPTION	QTY
68104871	KC11V3006 Bypass Valve Assembly	1

(Not Shown) Order No. 68104967.
 (Description: KC11V3191-01 Bypass Vertical Adapter Assembly.)

ORDER #	DESCRIPTION	QTY
68104967	KC11V3191-01 Bypass Vertical Adapter 1 Assembly	1

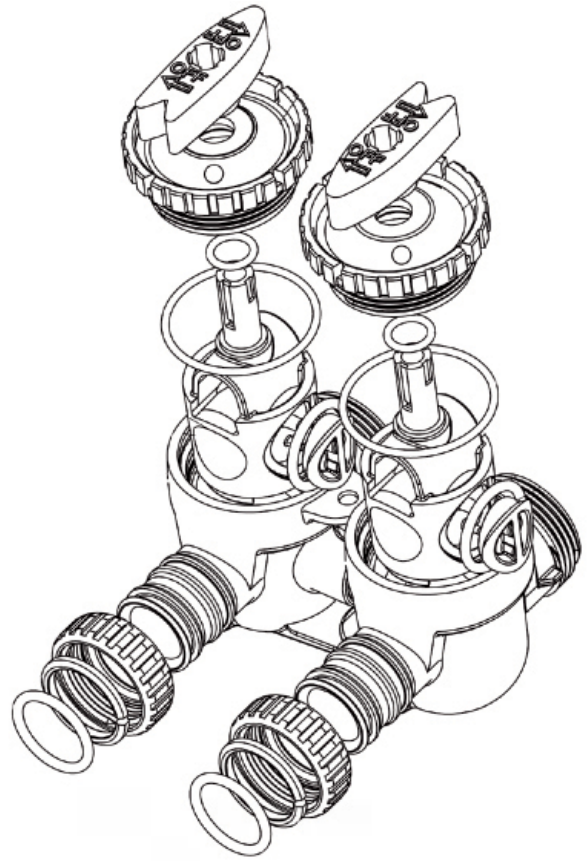

W100SM WRENCH

(Order No. 68104968)

Although no tools are necessary to assemble or disassemble the valve, the CLS-100 wrench (shown in various positions on the valve) may be purchased to aid in assemble or disassembly.

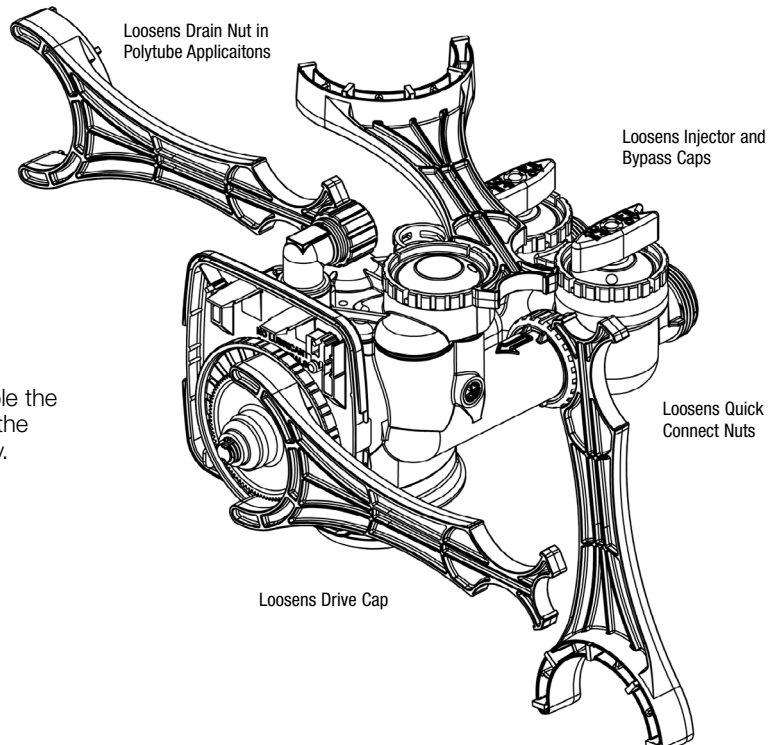

Flow Diagrams

Service

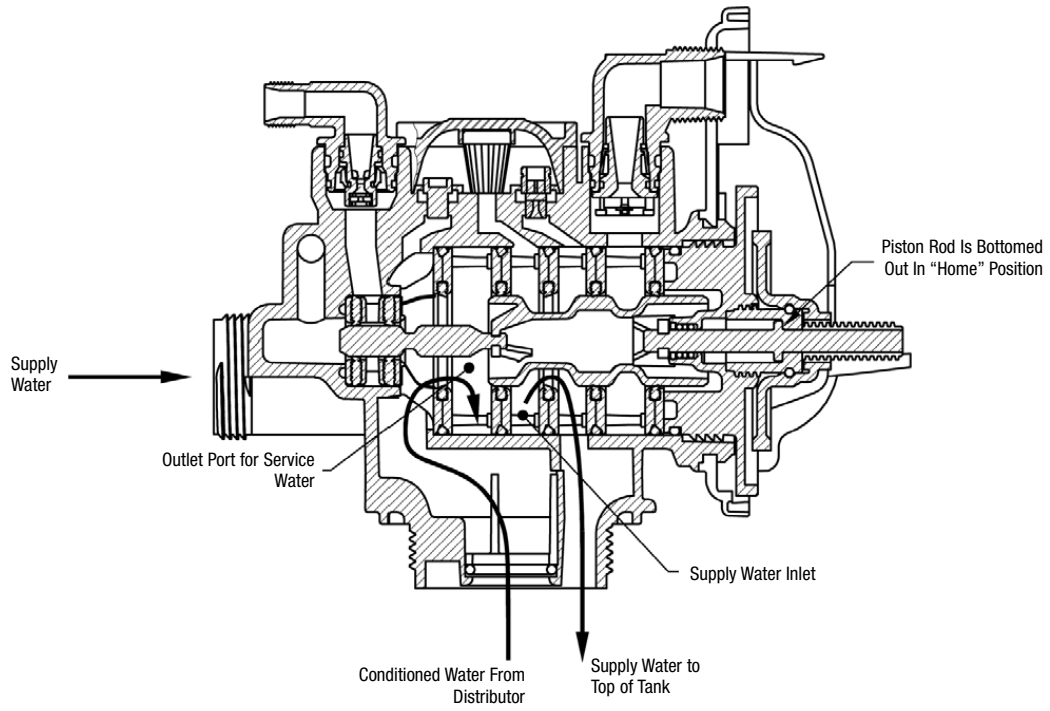

Backwash

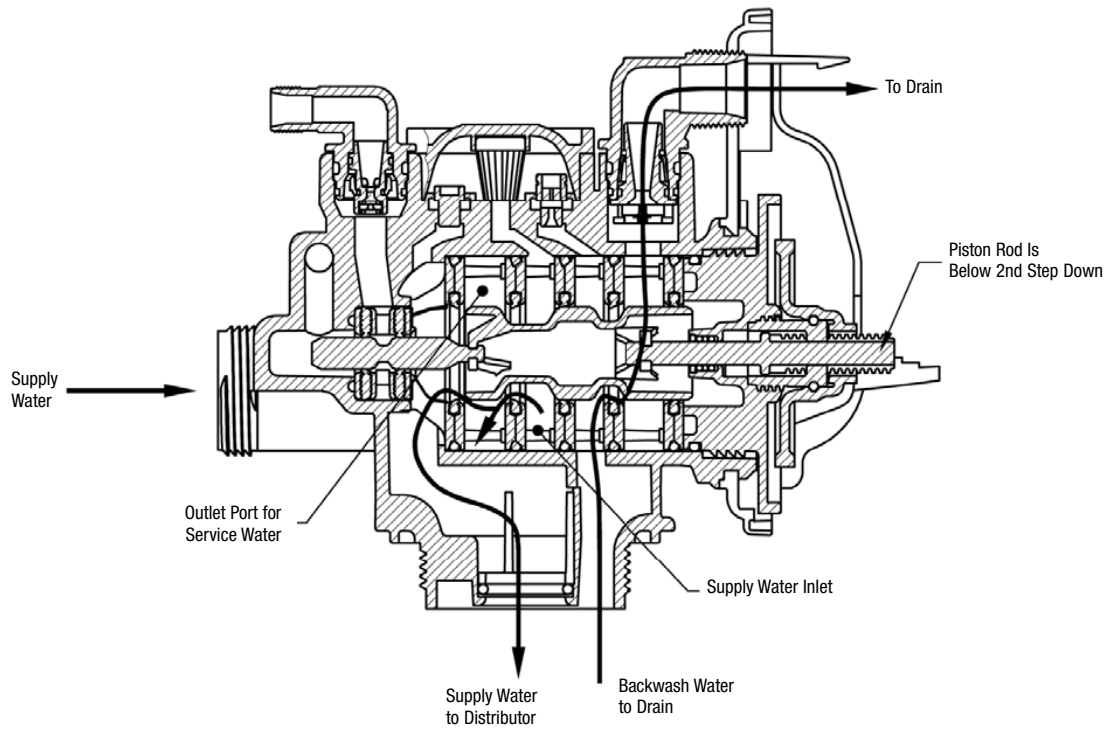

Flow Diagrams

Air Draw

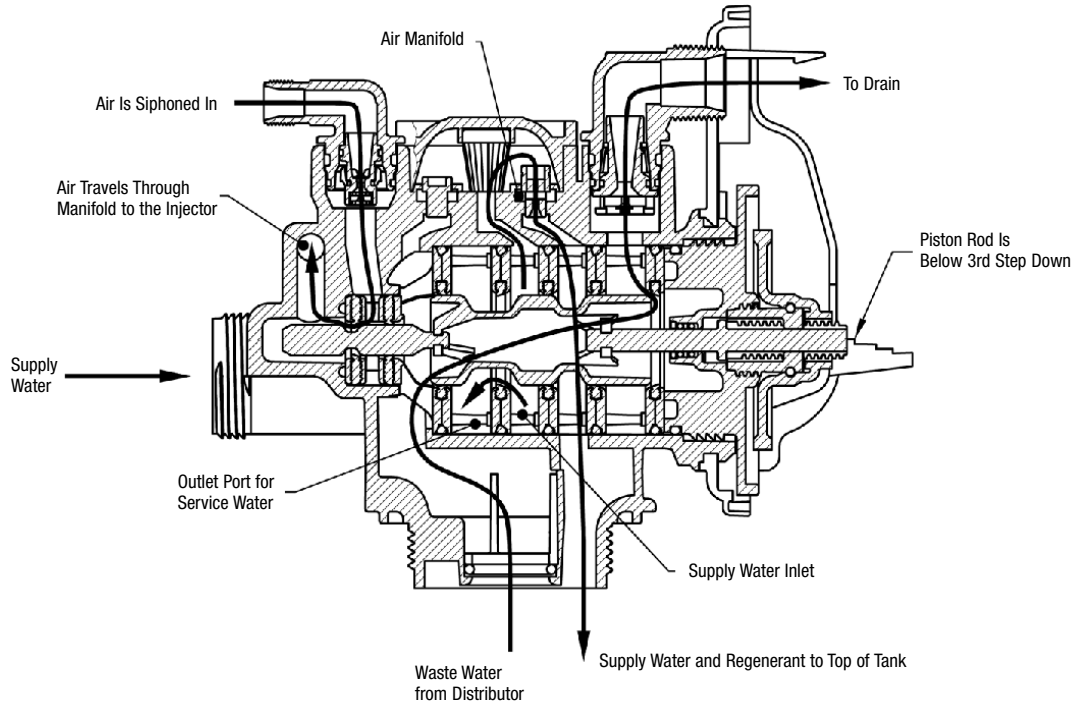

Rinse

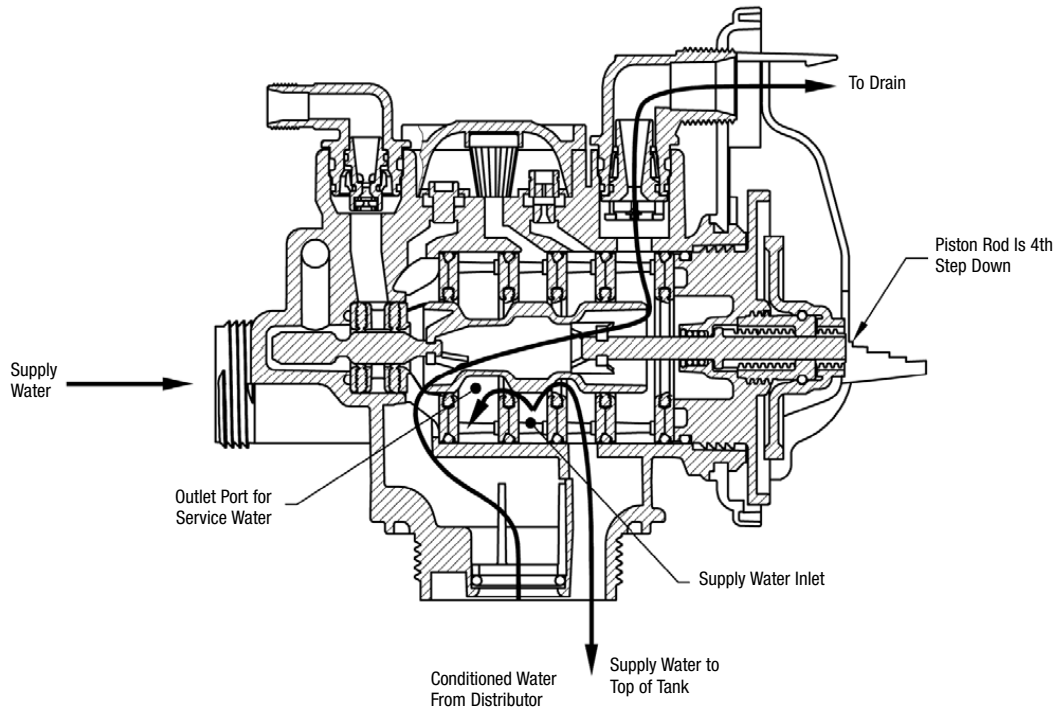

Troubleshooting

PROBLEM	POSSIBLE CAUSE	SOLUTION
No Display on PC Board	No power at electric outlet	Repair outlet or use working outlet
	Control valve Power Adapter not plugged into outlet or power cord end not connected to PC board connection	Plug Power Adapter into outlet or connect power cord end to PC Board connection
	Improper power supply	Verify proper voltage is being delivered to PC Board
	Defective Power Adapter	Replace Power Adapter
	Defective PC Board	Replace PC Board
PC Board does not display correct time of day	Power Adapter plugged into electric outlet controlled by light switch	Use uninterrupted outlet
	Tripped breaker switch and/or tripped GFI	Reset breaker switch and/ or GFI switch
	Power outage	Reset time of day. If PC Board has battery back up present the battery may be depleted. See Front Cover and Drive Assembly drawing for instructions.
	Defective PC Board	Replace PC Board
Display does not indicate that water is flowing. Refer to user instructions for how the display indicates water is flowing	Bypass valve in bypass position	Turn bypass handles to place bypass in service position
	Meter is not connected to meter connection on PC Board	Connect meter to three pin connection labeled METER on PC Board
	Restricted/ stalled meter turbine	Remove meter and check for rotation or foreign material
	Meter wire not installed securely into three pin connector	Verify meter cable wires are installed securely into three pin connector labeled METER
	Defective meter	Replace meter
	Defective PC Board	Replace PC Board
Control valve regenerates at wrong time of day	Power outage	Reset time of day. If PC Board has battery back up present the battery may be depleted. See Front Cover and Drive Assembly drawing for instructions.
	Time of day not set correctly	Reset to correct time of day
	Time of regeneration set incorrectly	Reset regeneration time
	Control valve set at "on 0" (immediate regeneration)	Check programming setting and reset to NORMAL (for a delayed regen time)
	Control valve set at "NORMAL + on 0" (delayed and/ or immediate)	Check programming setting and reset to NORMAL (for a delayed regen time)
Time of day flashes on and off	Power outage	Reset time of day. If PC Board has battery back up present the battery may be depleted. See Front Cover and Drive Assembly drawing for instructions.
Control valve does not regenerate automatically when the REGEN button is depressed and held.	Broken drive gear or drive cap assembly	Replace drive gear or drive cap assembly
	Broken Piston Rod	Replace piston rod
	Defective PC Board	Defective PC Board
Control valve does not regenerate automatically but does when the REGEN button is depressed and held.	Bypass valve in bypass position	Turn bypass handles to place bypass in service position
	Meter is not connected to meter connection on PC Board	Connect meter to three pin connection labeled METER on PC Board
	Restricted/ stalled meter turbine	Remove meter and check for rotation or foreign material
	Incorrect programming	Check for programming error
	Meter wire not installed securely into three pin connector	Verify meter cable wires are installed securely into three pin connector labeled METER
	Defective meter	Replace meter
	Defective PC Board	Replace PC Board

Troubleshooting

PROBLEM	POSSIBLE CAUSE	SOLUTION
Hard or untreated water is being delivered	Bypass valve is open or faulty	Fully close bypass valve or replace
	Media is exhausted due to high water usage	Check program settings or diagnostics for abnormal water usage
	Meter not registering	Remove meter and check for rotation or foreign material
	Water quality fluctuation	Test water and adjust program values accordingly
	No regenerant or low level of regenerant in regenerant tank	Add proper regenerant to tank
	Control fails to draw in regenerant	Refer to Trouble Shooting Guide number 12
	Insufficient regenerant level in regenerant tank	Check refill setting in programming. Check refill flow control for restrictions or debris and clean or replace
	Damaged seal/stack assembly	Replace seal/stack assembly
	Control valve body type and piston type mix matched	Verify proper control valve body type and piston type match
	Fouled media bed	Replace media bed
Control valve uses too much regenerant	Improper refill setting	Check refill setting
	Improper program settings	Check program setting to make sure they are specific to the water quality and application needs
	Control valve regenerates frequently	Check for leaking fixtures that may be exhausting capacity or system is undersized
Residual regenerant being delivered to service	Low water pressure	Check incoming water pressure – water pressure must remain at minimum of 25 psi
	Incorrect injector size	Replace injector with correct size for the application
	Restricted drain line	Check drain line for restrictions or debris and clean
Excessive water in regenerant tank	Improper program settings	Check refill setting
	Plugged injector	Remove injector and clean or replace
	Drive cap assembly not tightened in properly	Re-tighten the drive cap assembly
	Damaged seal/ stack assembly	Replace seal/ stack
	Restricted or kinked drain line	Check drain line for restrictions or debris and or un-kink drain line
	Plugged backwash flow controller	Remove backwash flow controller and clean or replace
	Missing refill flow controller	Replace refill flow controller
Control valve fails to draw in regenerant	Injector is plugged	Remove injector and clean or replace
	Faulty regenerant piston	Replace regenerant piston
	Regenerant line connection leak	Inspect regenerant line for air leak
	Drain line restriction or debris cause excess back pressure	Inspect drain line and clean to correct restriction
	Drain line too long or too high	Shorten length and or height
	Low water pressure	Check incoming water pressure – water pressure must remain at minimum of 25 psi
Water running to drain	Power outage during regeneration	Upon power being restored control will finish the remaining regeneration time. Reset time of day.
	Damaged seal/ stack assembly	Replace seal/ stack assembly
	Piston assembly failure	Replace piston assembly
	Drive cap assembly not tightened in properly	Re-tighten the drive cap assembly

Troubleshooting

PROBLEM	POSSIBLE CAUSE	SOLUTION
E1, Err – 1001, Err – 101 = Control unable to sense motor movement	Motor not inserted full to engage pinion, motor wires broken or disconnected	Disconnect power, make sure motor is fully engaged, check for broken wires, make sure two pin connector on motor is connected to the two pin connection on the PC Board labeled MOTOR. Press NEXT and REGEN buttons for 3 seconds to resynchronize software with piston position or disconnect power supply from PC Board for 5 seconds and then reconnect.
	PC Board not properly snapped into drive bracket	Properly snap PC Board into drive bracket and then Press NEXT and REGEN buttons for 3 seconds to resynchronize software with piston position or disconnect power supply from PC Board for 5 seconds and then reconnect.
	Missing reduction gears	Replace missing gears
E2, Err – 1002, Err – 102 = Control valve motor ran too short and was unable to find the next cycle position and stalled	Foreign material is lodged in control valve	Open up control valve and pull out piston assembly and seal/ stack assembly for inspection. Press NEXT and REGEN buttons for 3 seconds to resynchronize software with piston position or disconnect power supply from PC Board for 5 seconds and then reconnect.
	Mechanical binding	Check piston and seal/ stack assembly, check reduction gears, check drive bracket and main drive gear interface. Press NEXT and REGEN buttons for 3 seconds to resynchronize software with piston position or disconnect power supply from PC Board for 5 seconds and then reconnect.
	Main drive gear too tight	Loosen main drive gear. Press NEXT and REGEN buttons for 3 seconds to resynchronize software with piston position or disconnect power supply from PC Board for 5 seconds and then reconnect.
	Improper voltage being delivered to PC Board	Verify that proper voltage is being supplied. Press NEXT and REGEN buttons for 3 seconds to resynchronize software with piston position or disconnect power supply from PC Board for 5 seconds and then reconnect.
E3, Err – 1003, Err – 103 = Control valve motor ran too long and was unable to find the next cycle position	Motor failure during a regeneration	Check motor connections then Press NEXT and REGEN buttons for 3 seconds to resynchronize software with piston position or disconnect power supply from PC Board for 5 seconds and then reconnect.
	Foreign matter built up on piston and stack assemblies creating friction and drag enough to time out motor	Replace piston and stack assemblies. Press NEXT and REGEN buttons for 3 seconds to resynchronize software with piston position or disconnect power supply from PC Board for 5 seconds and then reconnect.
	Drive bracket not snapped in properly and out enough that reduction gears and drive gear do not interface	Snap drive bracket in properly then Press NEXT and REGEN buttons for 3 seconds to resynchronize software with piston position or disconnect power supply from PC Board for 5 seconds and then reconnect.
Err – 1004, Err – 104 = Control valve motor ran too long and timed out trying to reach home position	Drive bracket not snapped in properly and out enough that reduction gears and drive gear do not interface	Snap drive bracket in properly then Press NEXT and REGEN buttons for 3 seconds to resynchronize software with piston position or disconnect power supply from PC Board for 5 seconds and then reconnect.
Err -1006, Err – 106, Err - 116 = MAV/ SEPS/ NHBP/ AUX MAV valve motor ran too long and unable to find the proper park position Motorized Alternating Valve = MAV Separate Source = SEPS No Hard Water Bypass = NHBP Auxiliary MAV = AUX MAV	Control valve programmed for ALT A or b, nHbP, SEPS, or AUX MAV with out having a MAV or NHBP valve attached to operate that function	Press NEXT and REGEN buttons for 3 seconds to resynchronize software with piston position or disconnect power supply from PC Board for 5 seconds and then reconnect. Then re-program valve to proper setting.
	MAV/ NHBP motor wire not connected to PC Board	Connect MAV/ NHBP motor to PC Board two pin connection labeled DRIVE. Press NEXT and REGEN buttons for 3 seconds to resynchronize software with piston position or disconnect power supply from PC Board for 5 seconds and then reconnect.
	MAV/ NHBP motor not fully engaged with reduction gears	Properly insert motor into casing, do not force into casing Press NEXT and REGEN buttons for 3 seconds to resynchronize software with piston position or disconnect power supply from PC Board for 5 seconds and then reconnect.
	Foreign matter built up on piston and stack assemblies creating friction and drag enough to time out motor	Replace piston and stack assemblies. Press NEXT and REGEN buttons for 3 seconds to resynchronize software with piston position or disconnect power supply from PC Board for 5 seconds and then reconnect.
Err – 1007, Err – 107, Err - 117 = MAV/ SEPS/ NHBP/ AUX MAV valve motor ran too short (stalled) while looking for proper park position Motorized Alternating Valve = MAV Separate Source = SEPS No Hard Water Bypass = NHBP Auxiliary MAV = AUX MAV	Foreign material is lodged in MAV/ NHBP valve	Open up MAV/ NHBP valve and check piston and seal/ stack assembly for foreign material. Press NEXT and REGEN buttons for 3 seconds to resynchronize software with piston position or disconnect power supply from PC Board for 5 seconds and then reconnect.
	Mechanical binding	Check piston and seal/ stack assembly, check reduction gears, drive gear interface, and check MAV/ NHBP black drive pinion on motor for being jammed into motor body. Press NEXT and REGEN buttons for 3 seconds to resynchronize software with piston position or disconnect power supply from PC Board for 5 seconds and then reconnect.

WATER SOFTENERS/FILTERS Limited Warranty:

The online warranty for this product is located on the Watts website (<https://www.watts.com/resources/warranty-information>), and in the event that the terms or conditions of this manual conflict with the online warranty, the terms and conditions of the online warranty shall control.

The Company warrants each fiberglass tank 13 inches in diameter and smaller to be free from defects in material and workmanship under normal usage for a period of ten years from the date of original shipment.

The Company warrants each fiberglass tank 14 inches in diameter and larger to be free from defects in material and workmanship under normal usage for a period of five years from the date of original shipment.

The Company warrants any size Salt Tank (Brine Tank) to be free from defects in material and workmanship under normal usage for a period of five years from the date of original shipment.

The Company warrants each Control valve to be free from defects in material and workmanship under normal usage for a period of five years from the date of original shipment.

The Company warrants diaphragm valve nests and related controls to be free from defects in material and workmanship under normal usage for a period of one year from the date of original shipment.

The Company warrants all other components to be free from defects in material and workmanship under normal usage for a period of one year from the date of original shipment.

Water softener resins subjected to iron, manganese and chlorine levels greater than 1ppm are expressly not covered by this warranty. Manganese greensand media and expendable media such as activated carbon, Filox[®], Micro-Z[®] and neutralizing media are also not covered by this warranty. In the event of a covered defect within the warranty period, the Company will, at its option, replace or recondition the product without charge.

Disclaimer of Warranty. THE WARRANTY SET FORTH HEREIN IS GIVEN EXPRESSLY AND IS THE ONLY WARRANTY GIVEN BY THE COMPANY WITH RESPECT TO THE PRODUCT. THE COMPANY MAKES NO OTHER WARRANTIES, EXPRESS OR IMPLIED. THE COMPANY HEREBY SPECIFICALLY DISCLAIMS ALL OTHER WARRANTIES, EXPRESS OR IMPLIED, INCLUDING BUT NOT LIMITED TO THE IMPLIED WARRANTIES OF MERCHANTABILITY AND FITNESS FOR A PARTICULAR PURPOSE.

Limitation of Liability. The remedy described in the first paragraph of this warranty shall constitute the sole and exclusive remedy for breach of warranty, and the Company shall not be responsible for any incidental, special or consequential damages, including without limitation, lost profits or the cost of repairing or replacing other property which is damaged if this product does not work properly, other costs resulting from labor charges, delays, vandalism, negligence, fouling caused by foreign material, damage from adverse water conditions, chemical, or any other circumstances over which the Company has no control. This warranty shall be invalidated by any abuse, misuse, misapplication, improper installation or improper maintenance or alteration of the product

Some States do not allow limitations on how long an implied warranty lasts, and some States do not allow the exclusion or limitation of incidental or consequential damages. Therefore the above limitations may not apply to you. This Limited Warranty gives you specific legal rights, and you may have other rights that vary from State to State. You should consult applicable state laws to determine your rights. **SO FAR AS IS CONSISTENT WITH APPLICABLE STATE LAW, ANY IMPLIED WARRANTIES THAT MAY NOT BE DISCLAIMED, INCLUDING THE IMPLIED WARRANTIES OF MERCHANTABILITY AND FITNESS FOR A PARTICULAR PURPOSE, ARE LIMITED IN DURATION TO ONE YEAR FROM THE DATE OF ORIGINAL SHIPMENT.**

