

Engineering Specification

Job Name _____

Contractor _____

Job Location _____

Approval _____

Engineer _____

Contractor's P.O. No. _____

Approval _____

Representative _____

Series W-PQ21X-16P

Automatic Air Vent Valves

$\frac{3}{8}$ " – 1"

Series W-PQ21X-16P Automatic Air Vent Valves provide automatic air venting for hot or cold water distribution systems. These vents purge air that may be in the water system.

The vent valve utilizes a float to actuate the valve plug which is located at the top of the valve. Once the air is displaced and the system pressure is sustained, the valve plug seals and prevents any water from escaping from the system.

The float vent can also operate as an anti-vacuum device since it will permit air to enter the system when it must be drained. It can also be installed to permit the separation and dispersal of air while fluid is actually circulating in the system.

Features

- Body and cover are stainless steel construction
- Air vent with silicone rubber seal
- Impurities do not usually affect function as maximum float line of water is always lower than the valve seal
- Float is high temperature resistant polypropylene
- Suitable for use with water or glycol systems (less than or equal to 50% ethylene glycol)
- Can be disassembled for inspection and cleaning



W-PQ21X-16P

NOTICE

This information is not intended to replace the full product installation and safety information available or the experience of a trained product installer. You are required to thoroughly read all installation instructions and product safety information before beginning the installation of this product.

Pressure – Temperature

Maximum working pressure: 232 psi (16 bar)

Temperature Range: -4°F to 230°F (-20°C to 110°C)

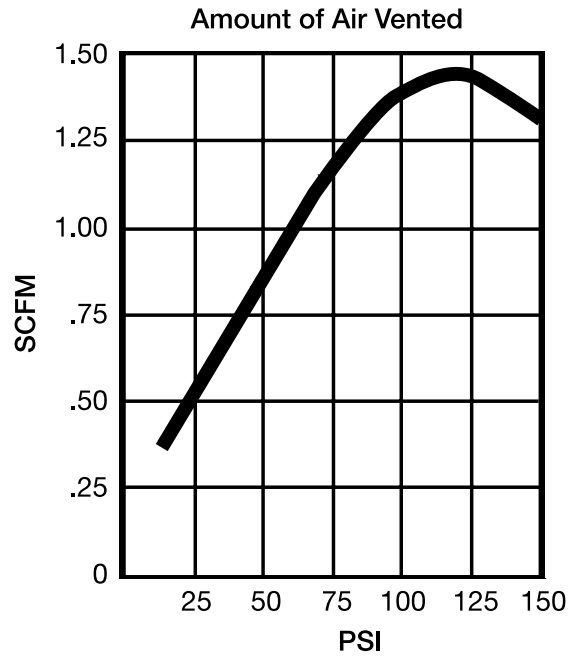
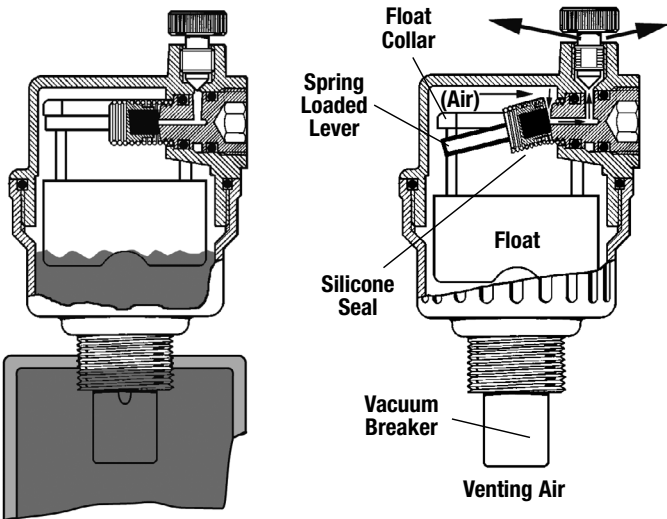
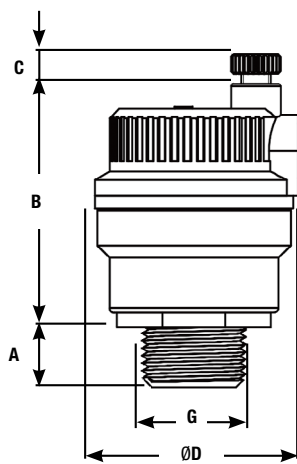

Diagram above shows the quantity of air vented by the "Float Vent" according to the pressure in the system.

Specification

Air vent shall have stainless steel body & cover and silicone rubber seal. Float shall be constructed of high temperature resistant polypropylene and shall be for use with glycol systems. Air vent shall be Watts Series W-PQ21X-16P.



3/8" and 1/2"

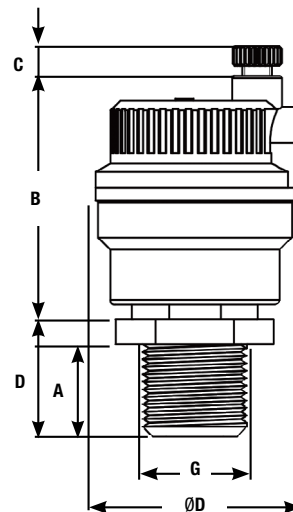

3/4" and 1"

Dimensions – Weights

Call customer service if you need assistance with technical details.

SIZE	DIMENSIONS										WEIGHT	
	A		B		C		D		ØD		lb	kg
<i>in</i>	<i>in</i>	<i>mm</i>	<i>in</i>	<i>mm</i>	<i>in</i>	<i>mm</i>	<i>in</i>	<i>mm</i>	<i>in</i>	<i>mm</i>		
3/8	3/8	10.0	1 ¹⁵ / ₁₆	49	5/16	7	-	-	1 ¹ / ₁₆	40	0.33	0.15
1/2	1/2	12.0	1 ¹⁵ / ₁₆	49	5/16	7	-	-	1 ¹ / ₁₆	40	0.34	0.16
3/4	3/4	18.5	1 ¹⁵ / ₁₆	49	5/16	7	1 ⁵ / ₁₆	23.5	1 ¹ / ₁₆	40	0.55	0.25
1	3/4	18.5	1 ¹⁵ / ₁₆	49	5/16	7	1 ⁵ / ₁₆	23.5	1 ¹ / ₁₆	40	0.69	0.31

Installation

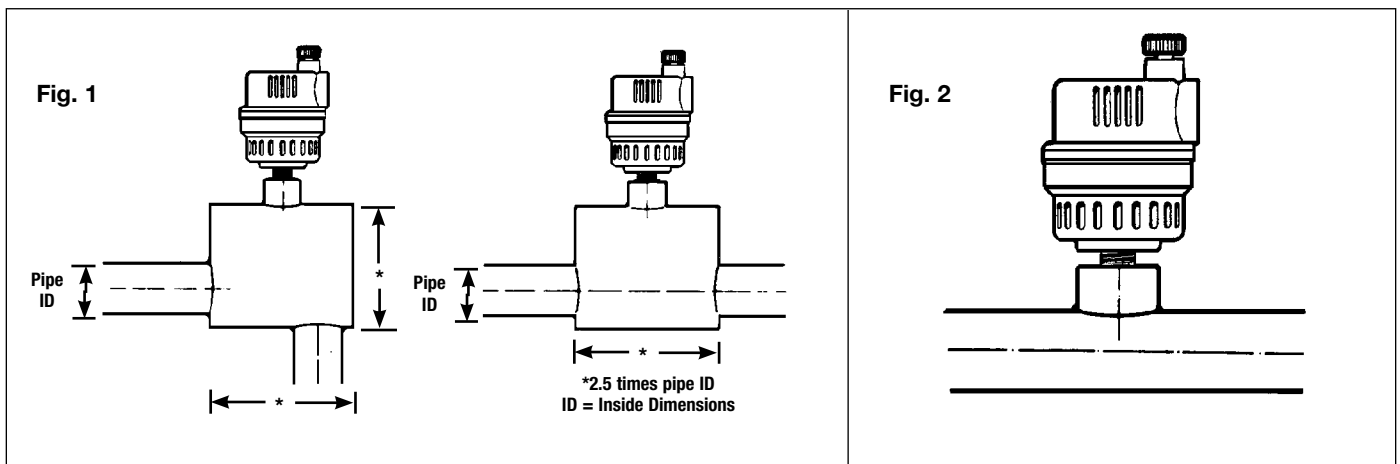

Figure 1 shows the installation of the W-PQ21X-16P for the venting of air while the fluid is circulating in the system. The figure shows the required increase in pipe size in order to obtain proper separation of air from water. Watts Series AS Air Scoop which is designed for efficient separation of air from water in hydronic heating systems can also be installed.

Figure 2 When the W-PQ21X-16P is installed as shown, the air will not be vented while the fluid is circulating in the system, but it can vent when the system is shut off.

The W-PQ21X-16P should be mounted only in a vertical position as its operation is based on the vertical movement of the float (see Fig. 3).

NOTICE

In order to get the best results in venting air from risers, use connecting pipes of at least 1/2" diameter between the "Float Vent" valves and the installation.

Maintenance

Corrosive water conditions, and/or unauthorized adjustments or repair could render the product ineffective for the service intended. Regular checking and cleaning of the product's internal components helps assure maximum life and proper function. When the W-PQ21X-16P is disassembled for inspection or cleaning, it is important that when re-assembling to ensure that the spring loaded lever properly engages under the float collar (see reverse side).

Operation

IMPORTANT

After installing the W-PQ21X-16P, back off the small vent cap two turns (see Fig. 4). This is the proper operating setting which will allow air to be vented from the system. It is advisable to leave the cap on to prevent impurities from entering the valve.

Fig. 3

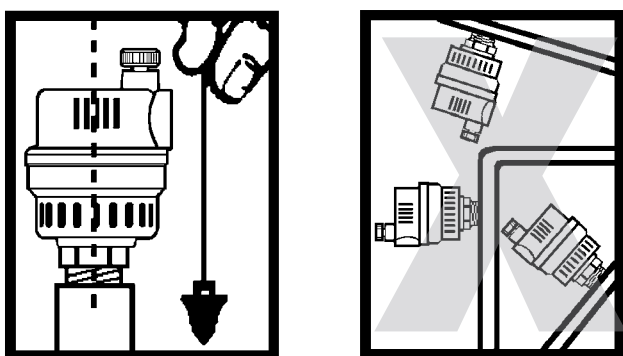

Fig. 4

