

Application Brochure

Smart Boiler Control 294





Application

Page

Central Heating With Up to Four Non-condensing Boilers	2
Central Heating and Side-Arm DHW With Up to Four Condensing Boilers	4
Central, DHW and Setpoint Heating With Two Condensing, Two Non-condensing Hybrid Boiler Plant	6
Central, DHW and Setpoint Heating With Up to Eight Condensing Boilers	8
Central and DHW Heating With Up to Four Condensing Boilers Using Variable Primary Flow Piping	12
Volume DHW Heating With Up to Four Water Heaters	14

⚠ WARNING

Please read carefully before proceeding with installation. Your failure to follow any attached instructions or operating parameters may lead to the product's failure.

Keep this Manual for future reference.



Description

Four single-stage non-condensing boilers with reverse-return piping operate to provide a central heating using outdoor reset.

Features:

- Central heating using outdoor air reset reduces the energy consumption up to 20% compared to fixed setpoint temperatures.
- Indoor feedback with optional wireless mesh indoor sensors to match heating to actual conditions of the building.
- PID staging automatically adjusts the number of boilers fired to match the load.
- Equal run time rotation automatically balances the run time of the boilers.
- Combustion air damper is opened before the first boiler is fired.
- Fixed lead with first on/first off supports venting systems that require the lead boiler to prime the vent.
- Programmable schedule to reduce energy consumption during unoccupied time periods.
- Warm weather shut down.
- Pressure monitoring with low and high pressure alert.
- Remote access from the Internet through the Nexa web or mobile applications.

Essential Boiler Settings:

Boiler Type = 1, 2, 3 or 4 stages

Boiler Group = Non-condensing

Essential System Settings:

Non-condensing Group Sequencing = Sequential

Non-condensing Group Rotation = On

Variable Primary Flow = Boiler Pumps

Legend

B1...B4 = On/Off Boilers 1 to 4

D1 = Combustion Air Damper

S1 = Outdoor Sensor 070 or Wireless Mesh Outdoor Sensor 043

S2 = Boiler Supply Sensor 082

S3 = Pressure Sensor 088 (Optional)

P1 = System Pump

V1 = Zone Valves

S4 = Wireless Indoor Sensor 042 (Optional)

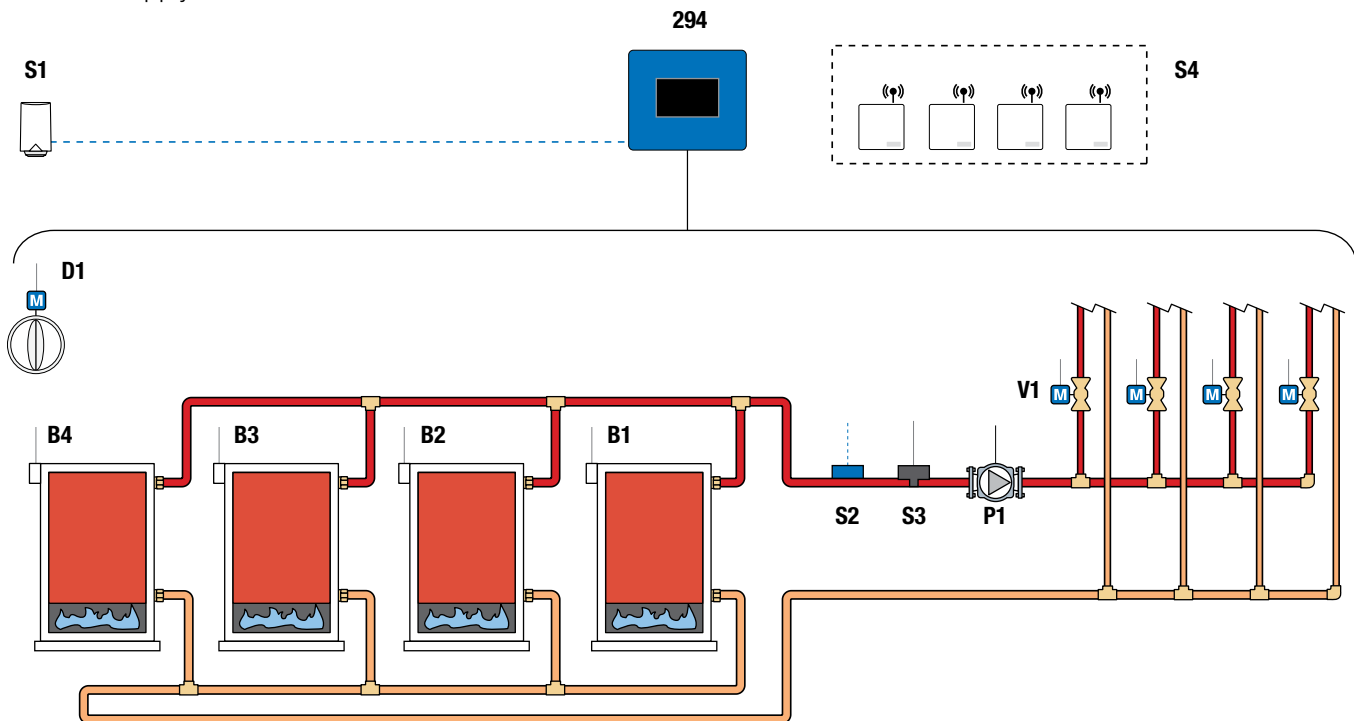

Concept Drawing: This is only a concept drawing, not an engineered drawing. It is not intended to describe a complete system, nor any particular system. It is up to the system designer to determine the necessary components for and configuration of the particular system being designed, including additional equipment, isolation relays (for loads greater than the control's specified output ratings), and any safety devices which in the judgement of the designer are appropriate, in order to properly size, configure and design that system and to ensure compliance with building and safety code requirements.

Legend

B1...B4 = On/Off Boilers 1 to 4

D1 = Combustion Air Damper

E1 = Ethernet (Optional)

S1 = Outdoor Sensor 070

S2 = Boiler Supply Sensor 082

S3 = Pressure Sensor 088 (Optional)

P1 = System Pump

V1 = Zone Valve End Switch

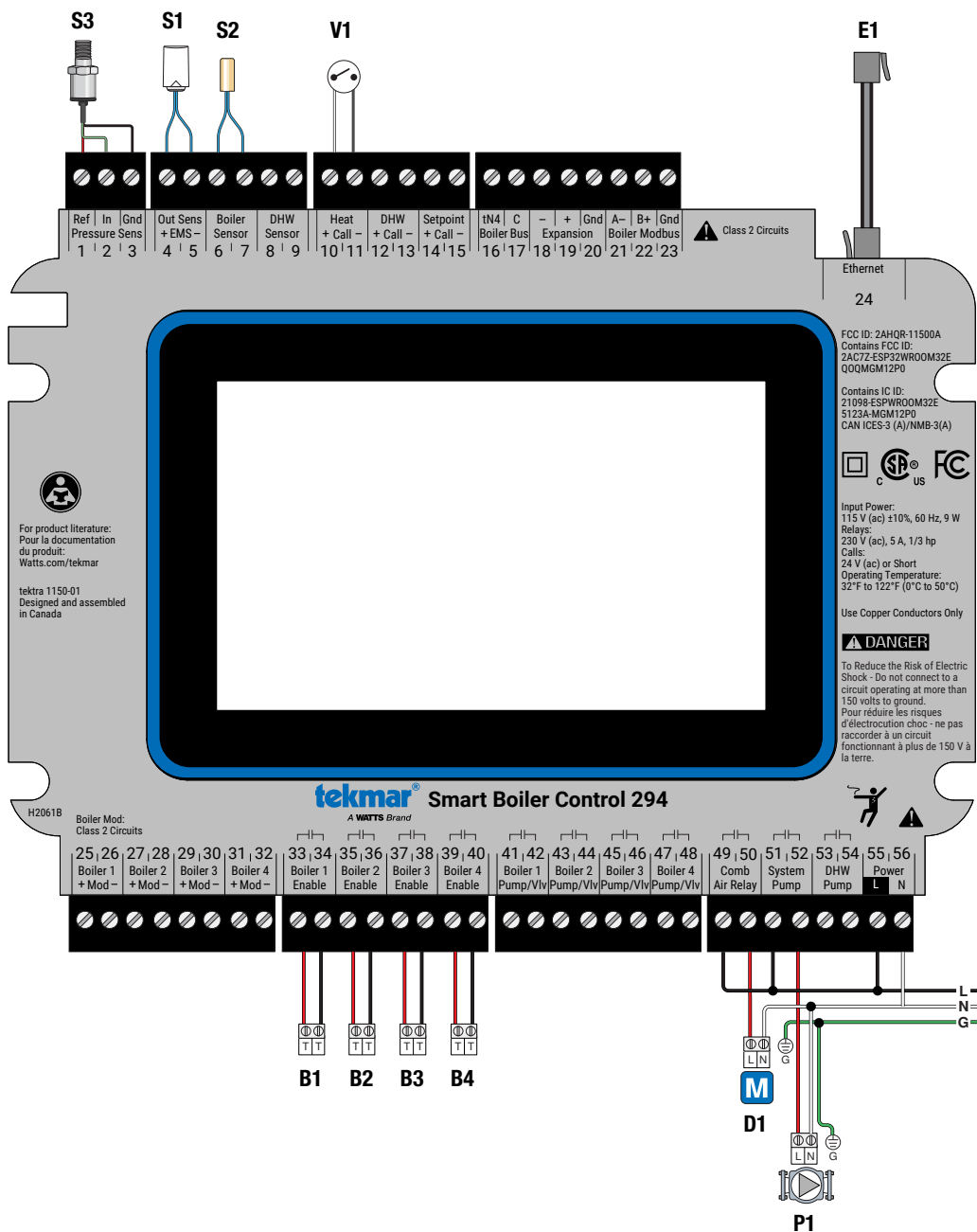

Concept Drawing: This is only a concept drawing, not an engineered drawing. It is not intended to describe a complete system, nor any particular system. It is up to the system designer to determine the necessary components and configuration of the particular system being designed, including additional equipment, isolation relays (for loads greater than the control's specified output ratings), and any safety devices which in the judgement of the designer are appropriate, in order to properly size, configure and design that system and to ensure compliance with building and safety code requirements.

Description

Four modulating condensing boilers operate to provide central heating using outdoor reset, and domestic hot water tank heating using side-arm piping to boiler 1.

Features:

- Central heating using outdoor air reset reduces the energy consumption up to 20% compared to fixed setpoint temperatures.
- Indoor feedback with optional wireless mesh indoor sensors to match heating to actual conditions of the building.
- Simultaneous central heating and domestic hot water heating using the DHW side-arm piping to boiler 1.
- PID staging automatically adjusts the number of boilers fired to match the load.
- Sequential or Parallel boiler sequencing.
- Equal run time rotation automatically balances the run time of the boilers.
- Boiler modbus communication to read lockout or hold error codes on boilers.
- Programmable schedule to reduce energy consumption during unoccupied time periods.
- Warm weather shut down.
- Pressure monitoring with low and high pressure alert.
- Remote access from the Internet through the Nexa web or mobile applications.

Essential Boiler Settings:

Boiler Type = Modulating Firing Rate or Modulating Target Temperature
 Boiler Group = Condensing

Essential System Settings:

Condensing Group Sequencing = Sequential or Parallel
 Condensing Group Rotation = On
 Variable Primary Flow = Boiler Pumps

Legend

- | | | |
|-------------------------------------------------------------|-------------------------------------|-------------------------------------------------|
| A1 = DHW Tank Aquastat | S2 = Boiler Supply Sensor 082 | V1 = Zone Valves |
| B1...B4 = Modulating Boilers 1 to 4 | S3 = Pressure Sensor 088 (Optional) | S5 = Wireless Mesh Indoor Sensor 042 (Optional) |
| BP1...BP4 = Boiler Pumps 1 to 4 | S4 = DHW Sensor 082 | |
| S1 = Outdoor Sensor 070 or Wireless Mesh Outdoor Sensor 043 | P1 = System Pump | |
| | P2 = DHW Pump | |

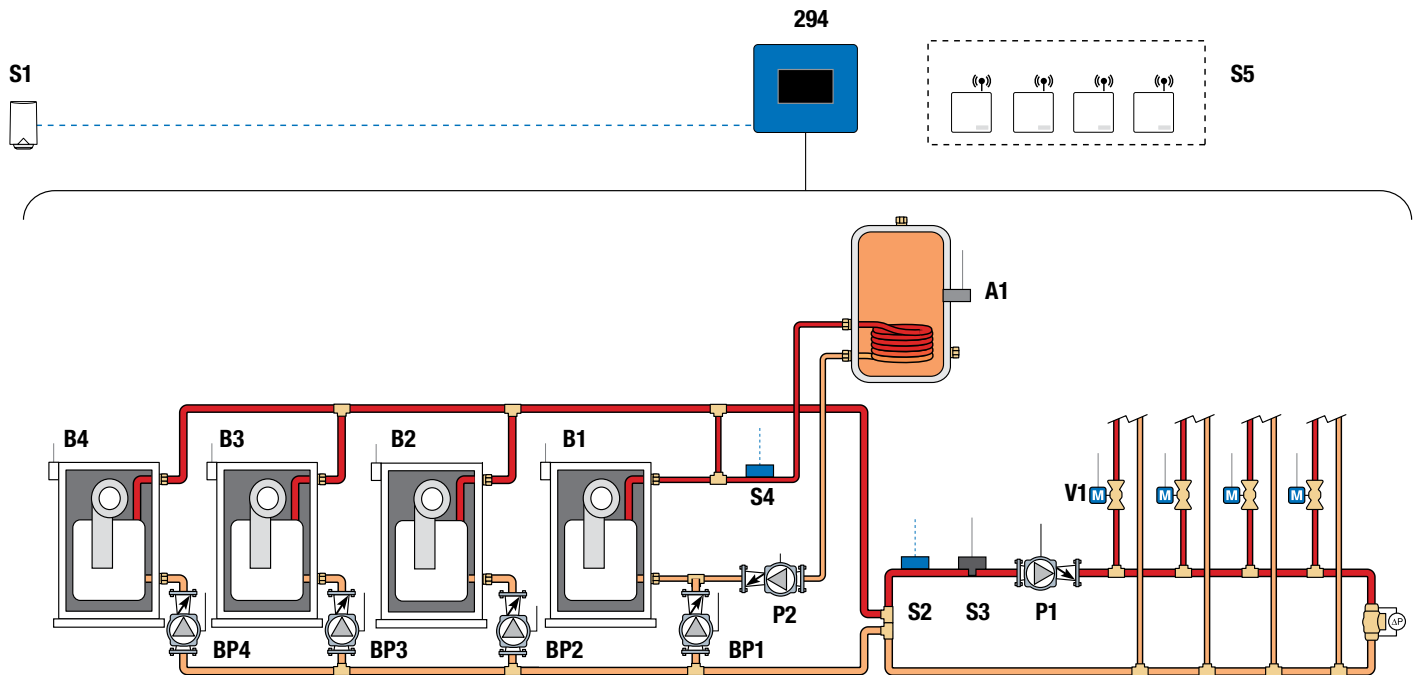

Concept Drawing: This is only a concept drawing, not an engineered drawing. It is not intended to describe a complete system, nor any particular system. It is up to the system designer to determine the necessary components for and configuration of the particular system being designed, including additional equipment, isolation relays (for loads greater than the control's specified output ratings), and any safety devices which in the judgement of the designer are appropriate, in order to properly size, configure and design that system and to ensure compliance with building and safety code requirements.

Legend

A1 = DHW Aquastat

B1...B4 = Boilers 1 to 4 Enable

BP1...BP4 = Boiler Pumps 1 to 4

C1 = Boiler Modbus Communication

E1 = Ethernet (Optional)

M1...M4 = Boiler Modulation Signals 1 to 4

S1 = Outdoor Sensor 070

S2 = Boiler Supply Sensor 082

S3 = Pressure Sensor 088 (Optional)

S4 = DHW Sensor 082

P1 = System Pump

P2 = DHW Pump

V1 = Zone Valve End Switch

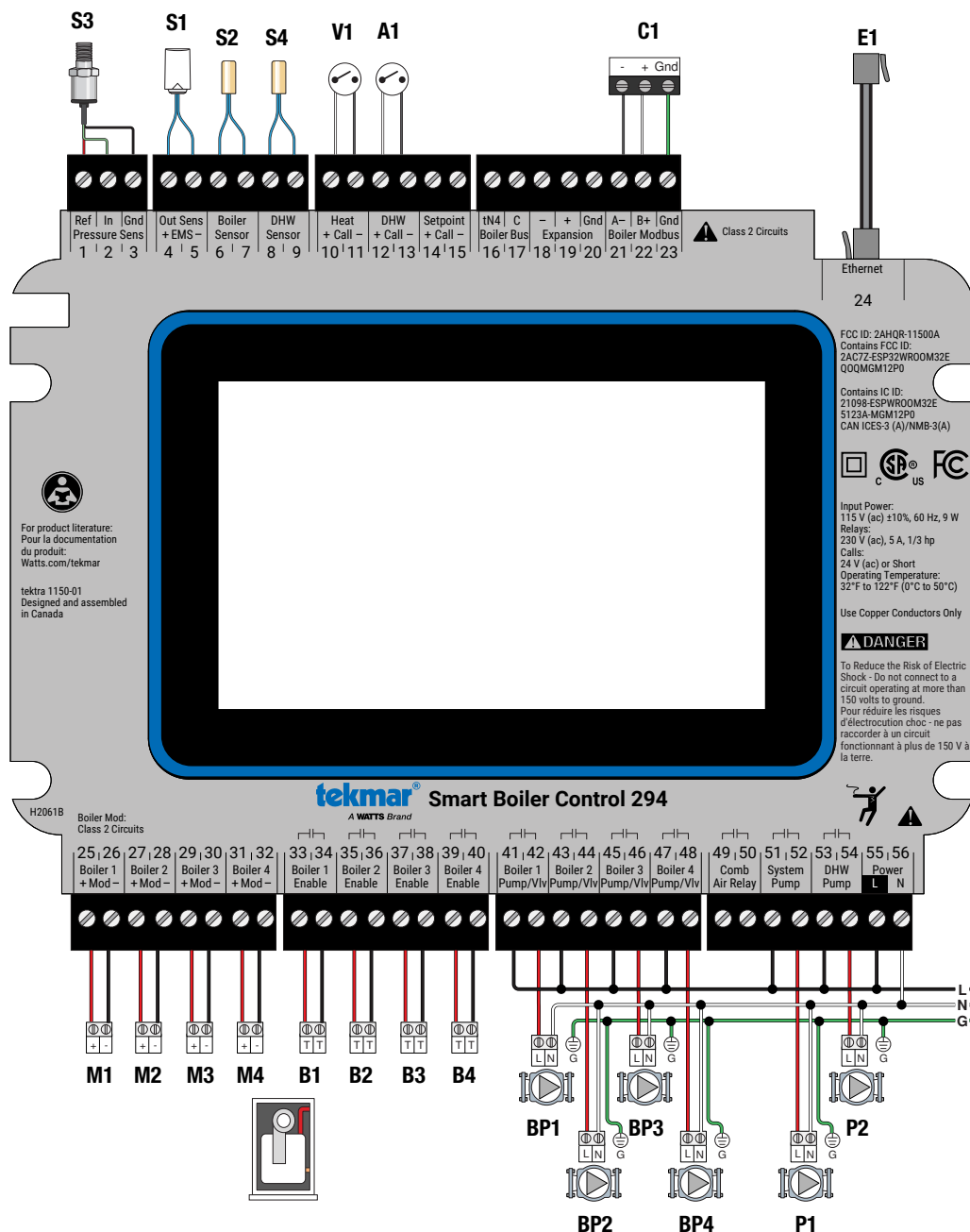

Concept Drawing: This is only a concept drawing, not an engineered drawing. It is not intended to describe a complete system, nor any particular system. It is up to the system designer to determine the necessary components for and configuration of the particular system being designed, including additional equipment, isolation relays (for loads greater than the control's specified output ratings), and any safety devices which in the judgement of the designer are appropriate, in order to properly size, configure and design that system and to ensure compliance with building and safety code requirements.

Description

Two modulating condensing boilers and two one-stage non-condensing boilers operate create a hybrid boiler plant to provide central heating using outdoor reset, domestic hot water and setpoint load heating. The two condensing boilers create a group to provide equal run time rotation. Likewise the two non-condensing boilers create a group that provide equal run time rotation. All condensing group boilers must fire before any non-condensing boilers are fired.

Features:

- Central heating using outdoor air reset reduces the energy consumption up to 20% compared to fixed setpoint temperatures.
- PID staging automatically adjusts the number of boilers fired to match the load.
- Sequential or Parallel boiler sequencing.
- Condensing and non-condensing boiler groups to operate hybrid boiler plants.
- Equal run time rotation automatically balances the run time of the condensing and non-condensing boiler groups.
- Boiler modbus communication to read lockout or hold error codes on boilers.
- Programmable schedule to reduce energy consumption during unoccupied time periods.
- Warm weather shut down.
- Pressure monitoring with low and high pressure alert.
- Remote access from the Internet through the Nexa web or mobile applications.

Essential Boiler Settings:

Boiler Type = Modulating Firing Rate or Modulating Target Temperature
 Boilers 1 and 2: Boiler Group = Condensing
 Boilers 3 and 4: Boiler Group = Non-condensing

Essential System Settings:

Condensing Group Sequencing = Sequential or Parallel
 Condensing Group Rotation = On
 Variable Primary Flow = Boiler Pumps

Legend

- | | | |
|----------------------------------------|-------------------------------------|-------------------------------|
| A1 = DHW Tank Aquastat | S2 = Boiler Supply Sensor 082 | P2 = DHW Pump |
| B1, B2 = Condensing Boiler 1 and 2 | S3 = Pressure Sensor 088 (Optional) | P3 = Setpoint Load Pump |
| B3, B4 = Non-condensing Boiler 3 and 4 | S4 = DHW Sensor 082 | V1 = Zone Valves |
| BP1...BP4 = Boiler Pumps 1 to 4 | T1...T4 = Thermostats | ZVC = Zone Valve Control 304V |
| S1 = Outdoor Sensor 070 | P1 = System Pump | |

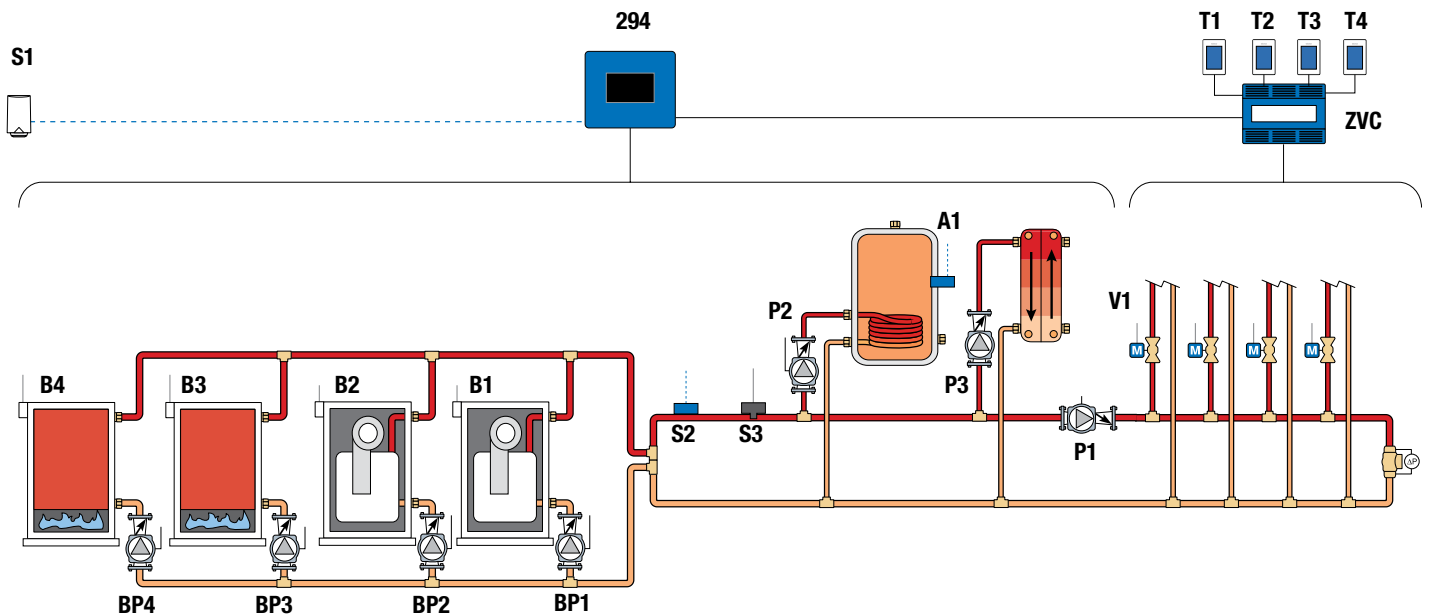

Concept Drawing: This is only a concept drawing, not an engineered drawing. It is not intended to describe a complete system, nor any particular system. It is up to the system designer to determine the necessary components for and configuration of the particular system being designed, including additional equipment, isolation relays (for loads greater than the control's specified output ratings), and any safety devices which in the judgement of the designer are appropriate, in order to properly size, configure and design that system and to ensure compliance with building and safety code requirements.

Legend

A1 = Zone Valve Control DHW Terminals
 A2 = Zone Valve Control Boiler XX Terminals
 A3 = Setpoint Load Call
 B1, B2 = Modulating Boiler 1 and 2 Enable
 B3, B4 = On-Off Boiler 3 and 4 Enable
 BP1...BP4 = Boiler Pumps 1 to 4

C1 = Boiler Modbus Communication
 E1 = Ethernet (Optional)
 M1, M2 = Boiler Modulation Signal 1 and 2
 S1 = Outdoor Sensor 070
 S2 = Boiler Supply Sensor 082
 S3 = Pressure Sensor 088 (Optional)

tN4 = Zone Valve Control
 tN4 and C
 P1 = System Pump
 P2 = DHW Pump

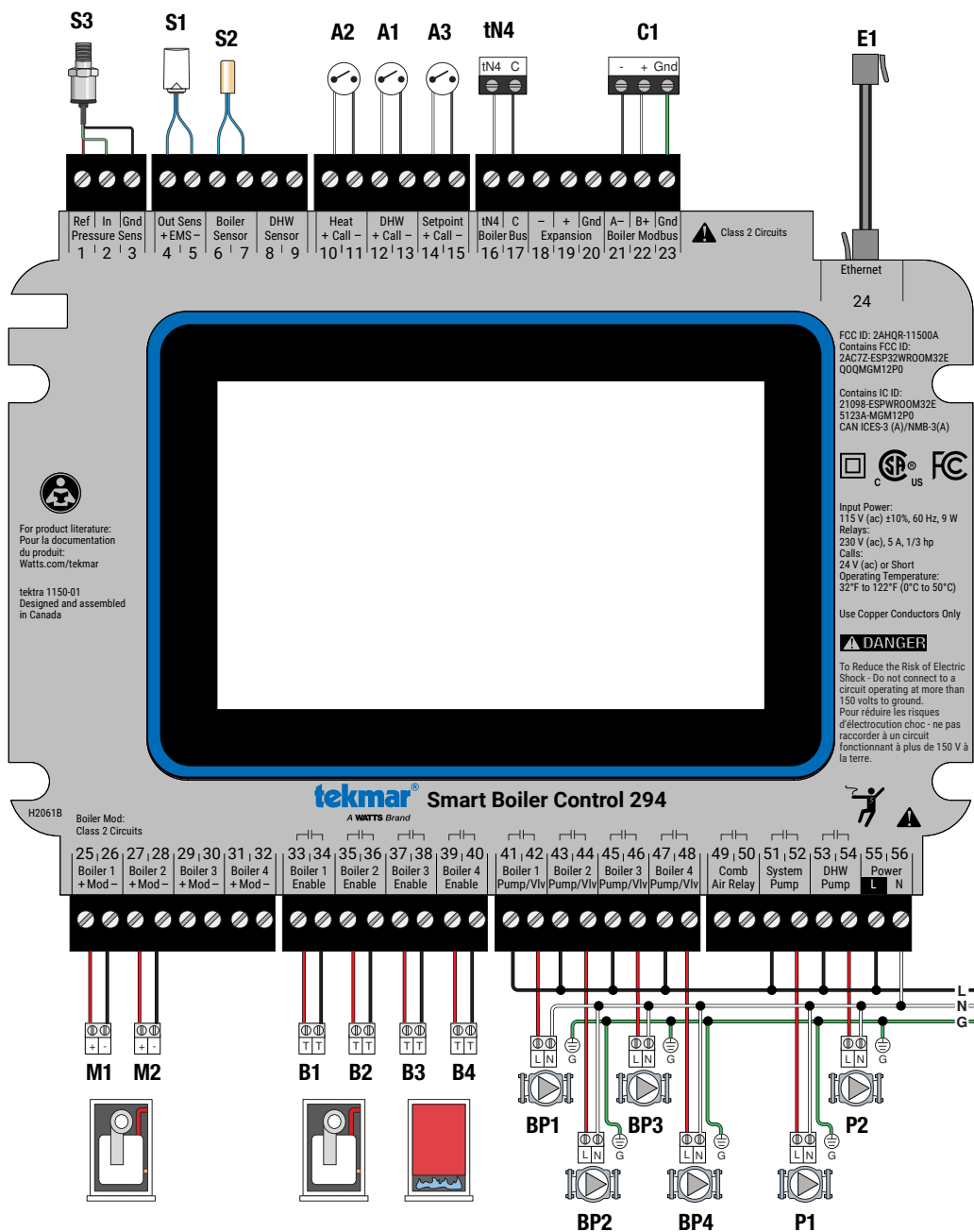

Concept Drawing: This is only a concept drawing, not an engineered drawing. It is not intended to describe a complete system, nor any particular system. It is up to the system designer to determine the necessary components for and configuration of the particular system being designed, including additional equipment, isolation relays (for loads greater than the control's specified output ratings), and any safety devices which in the judgement of the designer are appropriate, in order to properly size, configure and design that system and to ensure compliance with building and safety code requirements.

Description

Eight modulating condensing boilers are operated to provide central heating using outdoor reset, domestic hot water tank and setpoint load heating. The domestic hot water tank is located on the system loop.

Features:

- Central heating using outdoor air reset reduces the energy consumption up to 20% compared to fixed setpoint temperatures.
- Indoor feedback with optional wireless mesh indoor sensors to match heating to actual conditions of the building.
- PID staging automatically adjusts the number of boilers fired to match the load.
- Sequential or Parallel boiler sequencing.
- Sequencing of up to 8 boilers using Smart Boiler Expansion 294EXP (up to 16 boilers possible using three 294EXP).
- Equal run time rotation automatically balances the run time of the boilers.
- Boiler modbus communication to read lockout or hold error codes on boilers.
- Programmable schedule to reduce energy consumption during unoccupied time periods.
- Warm weather shut down.
- Pressure monitoring with low and high pressure alert.
- Remote access from the Internet through the Nexa web or mobile applications.

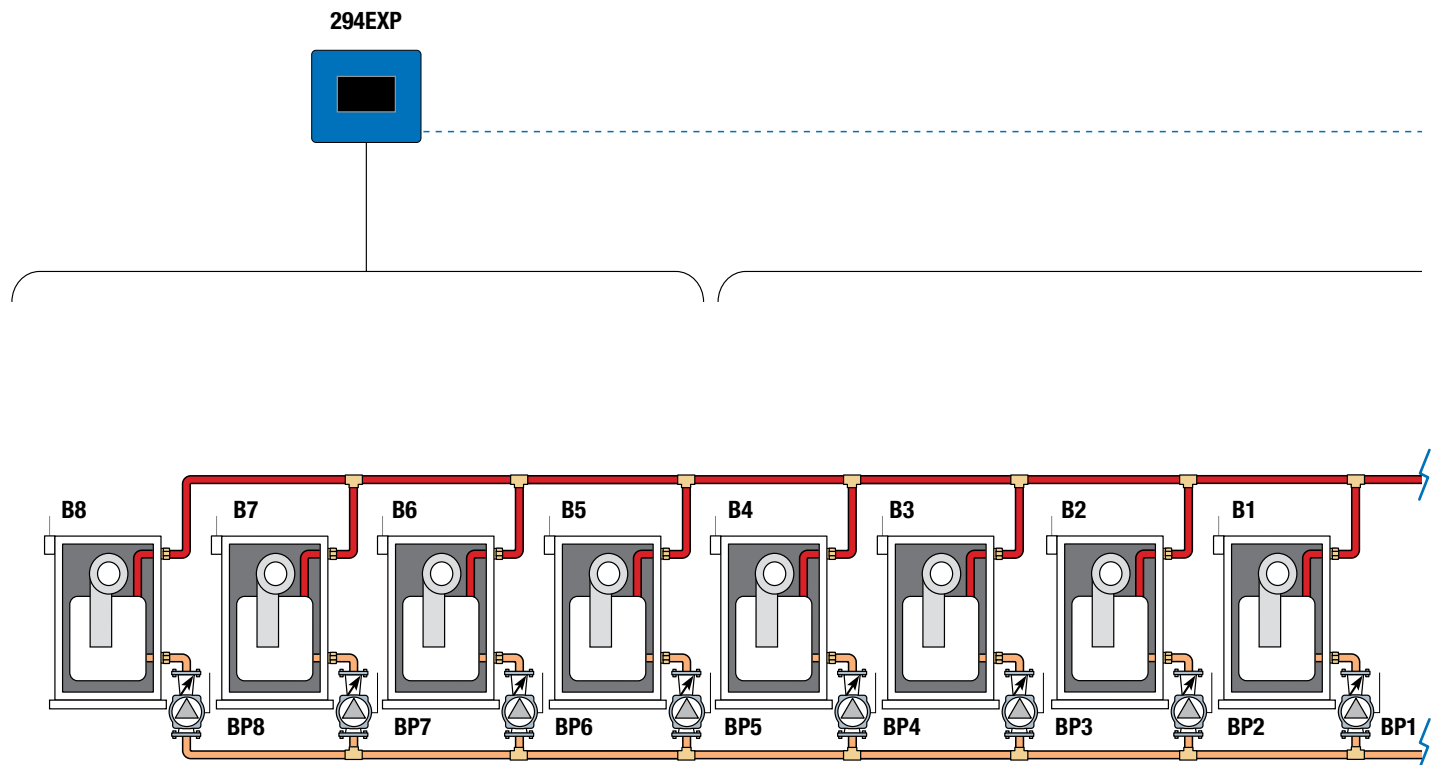

Concept Drawing: This is only a concept drawing, not an engineered drawing. It is not intended to describe a complete system, nor any particular system. It is up to the system designer to determine the necessary components for and configuration of the particular system being designed, including additional equipment, isolation relays (for loads greater than the control's specified output ratings), and any safety devices which in the judgement of the designer are appropriate, in order to properly size, configure and design that system and to ensure compliance with building and safety code requirements.

Legend

A1 = Setpoint Load Call	S2 = Boiler Supply Sensor 082	P1 = System Pump
B1...B8 = Modulating Boilers 1 to 8	S3 = Pressure Sensor 088 (Optional)	P2 = DHW Pump
BP1...BP8 = Boiler Pumps 1 to 8	S4 = DHW Sensor 078	P3 = Setpoint Load Pump
S1 = Outdoor Sensor 070 or Wireless Mesh Outdoor Sensor 043	S5 = Wireless Mesh Indoor Sensor 042 (Optional)	V1 = Thermostatic Radiator Valves

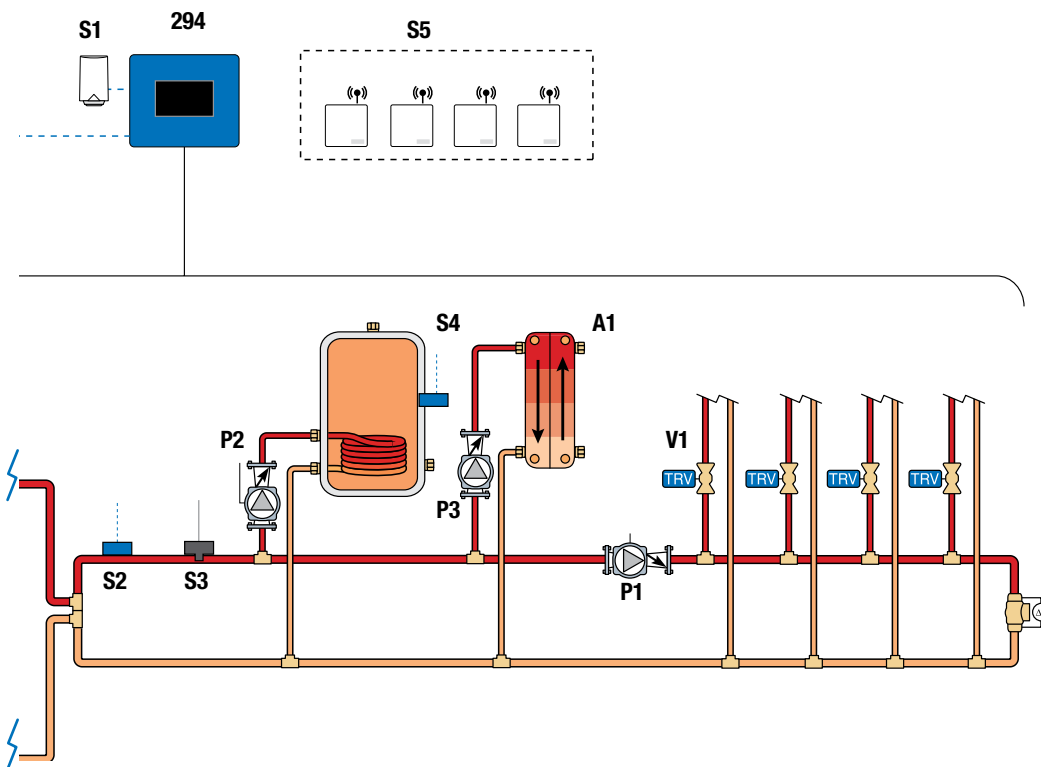

Concept Drawing: This is only a concept drawing, not an engineered drawing. It is not intended to describe a complete system, nor any particular system. It is up to the system designer to determine the necessary components for and configuration of the particular system being designed, including additional equipment, isolation relays (for loads greater than the control's specified output ratings), and any safety devices which in the judgement of the designer are appropriate, in order to properly size, configure and design that system and to ensure compliance with building and safety code requirements.

Legend

B5...B8 = Boiler On-Off Enable 5 to 8

BP5...BP48 = Boiler Pumps 5 to 8

M5...M8 = Boiler Modulation Signal 5 to 8

NOTICE

Set 294EXP DIP switches 1 and 2 to Off to operate boilers 5 through 8.

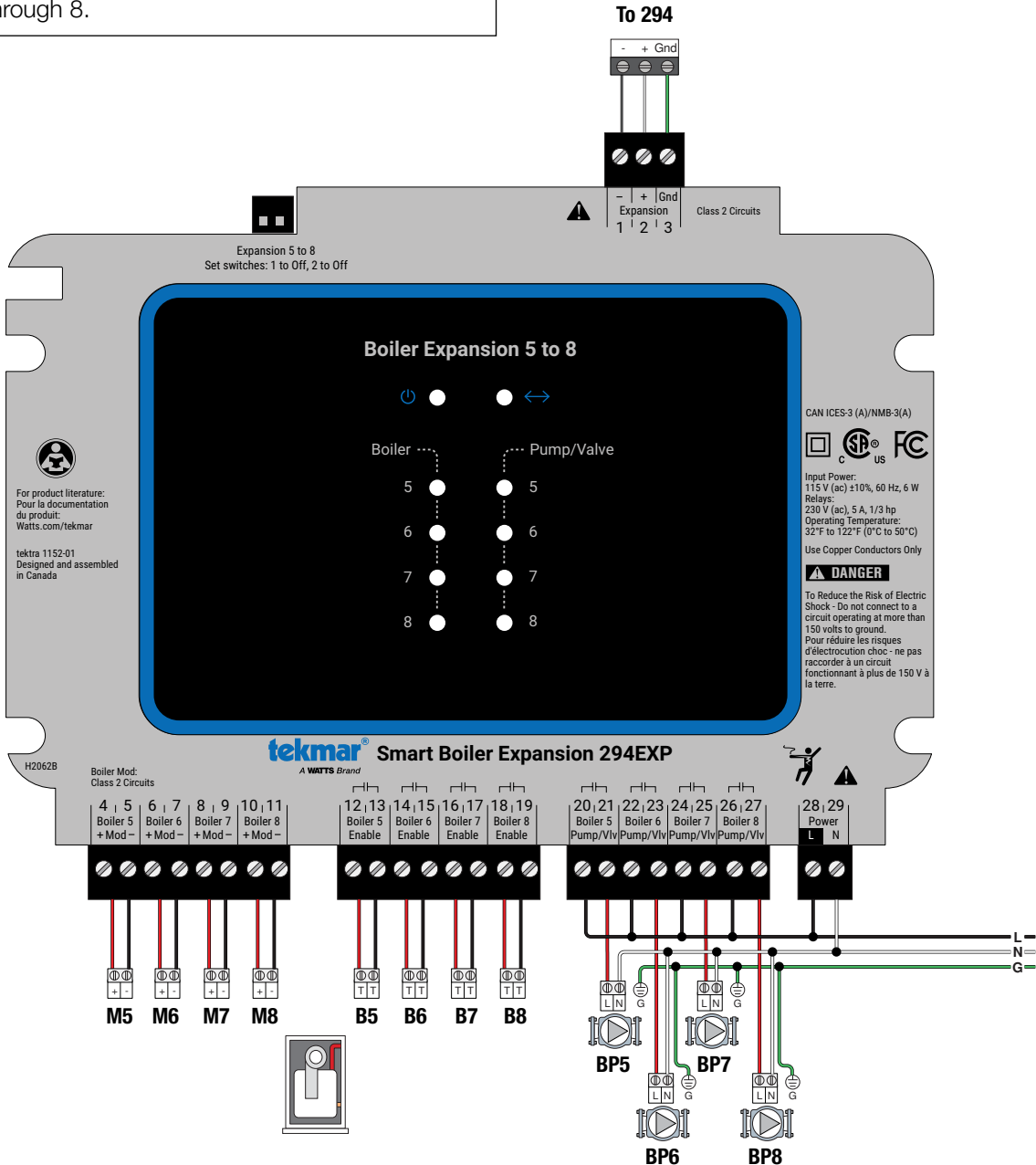

Concept Drawing: This is only a concept drawing, not an engineered drawing. It is not intended to describe a complete system, nor any particular system. It is up to the system designer to determine the necessary components and configuration of the particular system being designed, including additional equipment, isolation relays (for loads greater than the control's specified output ratings), and any safety devices which in the judgement of the designer are appropriate, in order to properly size, configure and design that system and to ensure compliance with building and safety code requirements.

Legend

- | | | |
|---------------------------------------|-------------------------------------------|-------------------------|
| A1 = Setpoint Load Call | J1 = Field Jumper | S4 = DHW Sensor 078 |
| B1...B4 = Boiler On-Off Enable 1 to 4 | M1...M4 = Boiler Modulation Signal 1 to 4 | P1 = System Pump |
| BP1...BP4 = Boiler Pumps 1 to 4 | S1 = Outdoor Sensor 070 | P2 = DHW Pump |
| C1 = Boiler Modbus Communication | S2 = Boiler Supply Sensor 082 | P3 = Setpoint Load Pump |
| E1 = Ethernet (Optional) | S3 = Pressure Sensor 088 (Optional) | |

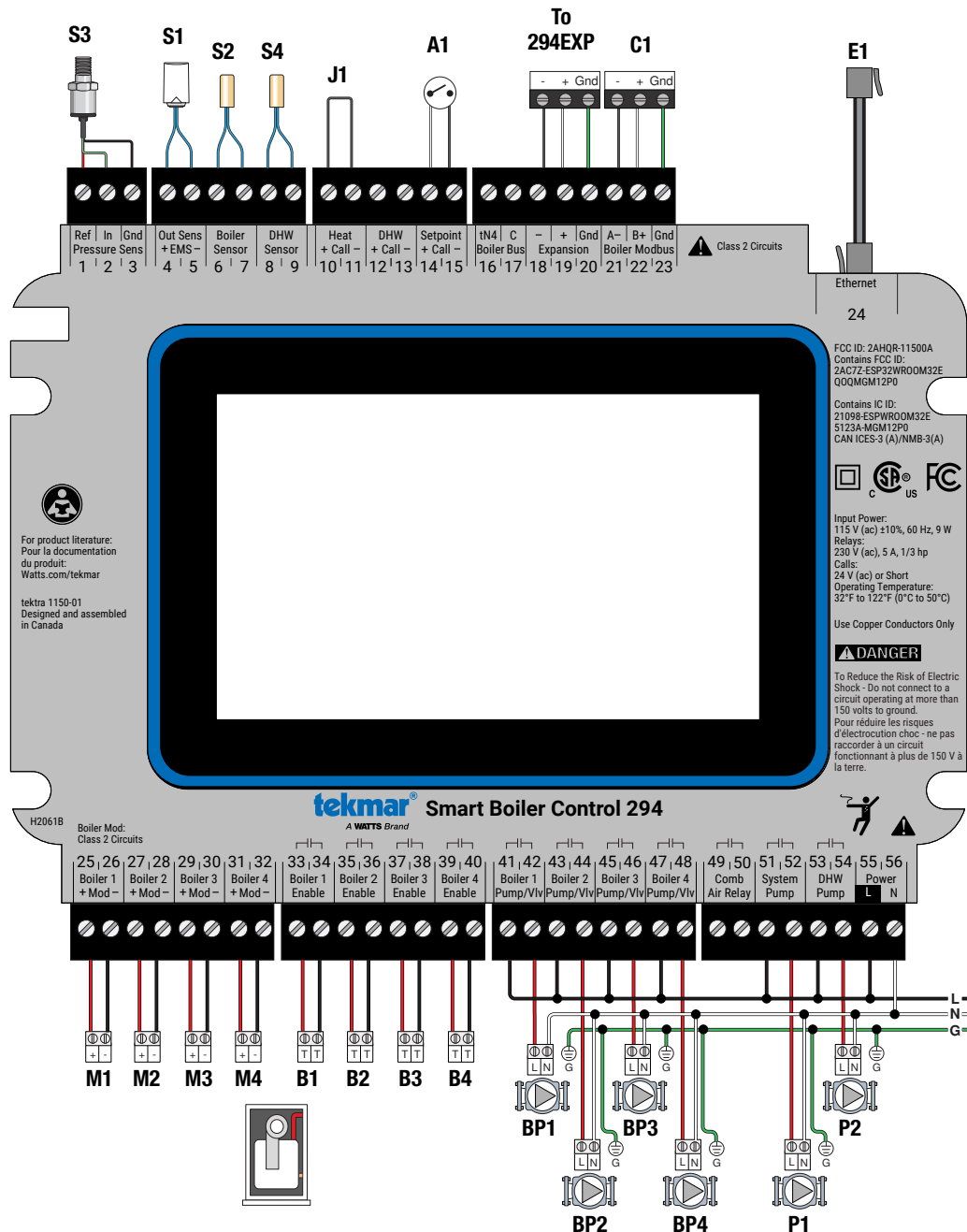

Concept Drawing: This is only a concept drawing, not an engineered drawing. It is not intended to describe a complete system, nor any particular system. It is up to the system designer to determine the necessary components for and configuration of the particular system being designed, including additional equipment, isolation relays (for loads greater than the control's specified output ratings), and any safety devices which in the judgement of the designer are appropriate, in order to properly size, configure and design that system and to ensure compliance with building and safety code requirements.

Description

Four modulating condensing boilers are piped using variable primary flow to a central heating system. The system pump uses its logic to maintain a constant pressure through the system and a minimum flow rate through the boilers. A domestic hot water tank is heated by an on-off pump piped in parallel to the system pump.

Features:

- Central heating using outdoor air reset reduces the energy consumption up to 20% compared to fixed setpoint temperatures.
- Indoor feedback with optional wireless mesh indoor sensors to match heating to actual conditions of the building.
- PID staging automatically adjusts the number of boilers fired to match the load.
- Sequential or Parallel boiler sequencing.
- Variable primary flow using boiler isolation valves allows the system pump to operate at lower speeds resulting in lower electrical usage. The isolation valves must be of the spring return, normally open / fail open type.
- Equal run time rotation automatically balances the run time of the boilers.
- Boiler modbus communication to read lockout or hold error codes on boilers.
- Programmable schedule to reduce energy consumption during unoccupied time periods.
- Warm weather shut down.
- Pressure monitoring with low and high pressure alert.
- Remote access from the Internet through the Nexa web or mobile applications.

Essential Boiler Settings:

Boiler Type = Modulating Firing Rate or Modulating
 Target Temperature
 Boiler Group = Condensing

Essential System Settings:

Condensing Group Sequencing = Sequential or Parallel
 Condensing Group Rotation = On
 Variable Primary Flow = Isolation Valves

Legend

- | | | |
|-------------------------------------------------------------|-------------------------------------------------|---------------------------------|
| B1...4 = Condensing Boilers 1 to 4 | S3 = Pressure Sensor 088 (Optional) | P1 = Variable Speed System Pump |
| BV1...BV4 = Boiler Isolation Valves 1 to 4 | S4 = DHW Sensor 078 | P2 = DHW Pump |
| S1 = Outdoor Sensor 070 or Wireless Mesh Outdoor Sensor 043 | S5 = Wireless Mesh Indoor Sensor 042 (Optional) | V1 = Zone Valves |
| S2 = Boiler Supply Sensor 082 | | |

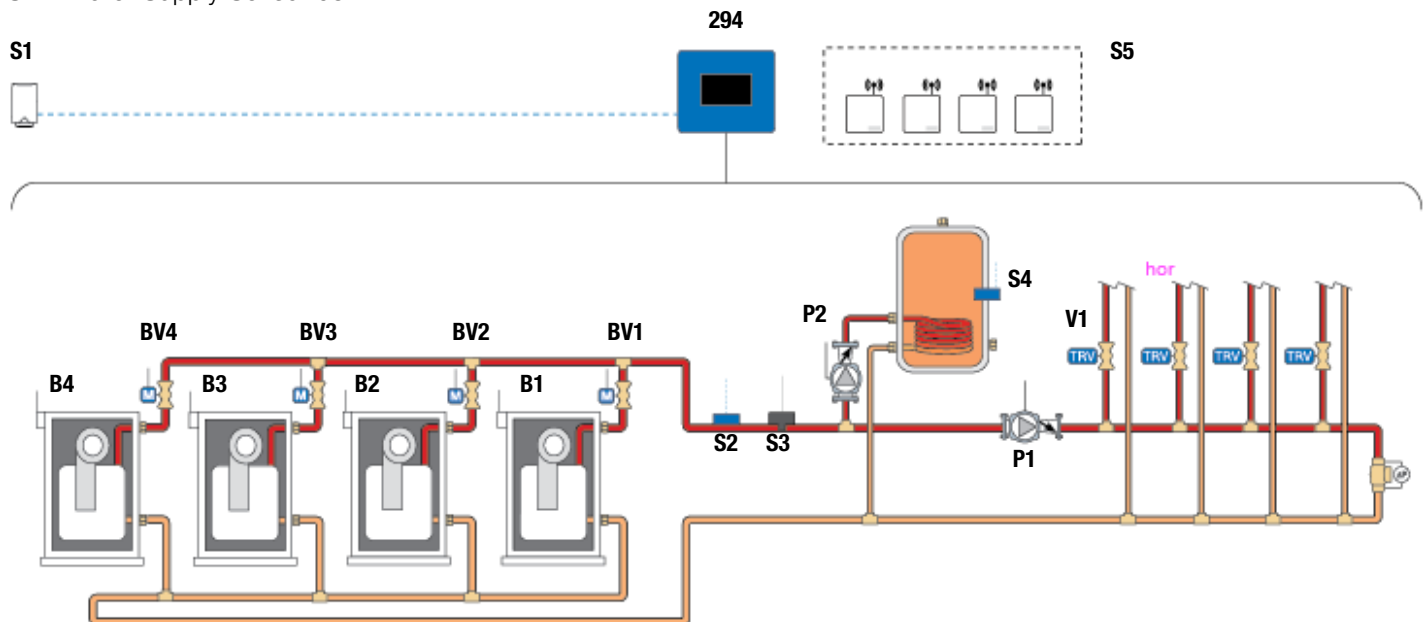

Concept Drawing: This is only a concept drawing, not an engineered drawing. It is not intended to describe a complete system, nor any particular system. It is up to the system designer to determine the necessary components for and configuration of the particular system being designed, including additional equipment, isolation relays (for loads greater than the control's specified output ratings), and any safety devices which in the judgement of the designer are appropriate, in order to properly size, configure and design that system and to ensure compliance with building and safety code requirements.

Legend

B1...4 = Boiler On-Off Enable 1 to 4

BV1...BV4 = Boiler Isolation Valves 1 to 4

C1 = Boiler Modbus Communication (Optional)

E1 = Ethernet (Optional)

J1 = Field Jumper

M1...M4 = Boiler Modulation Signal 1 to 4

S1 = Outdoor Sensor 070

S2 = Boiler Supply Sensor 082

S3 = Pressure Sensor 088 (Optional)

S4 = DHW Sensor 078

P1 = Variable Speed System Pump

P2 = DHW Pump

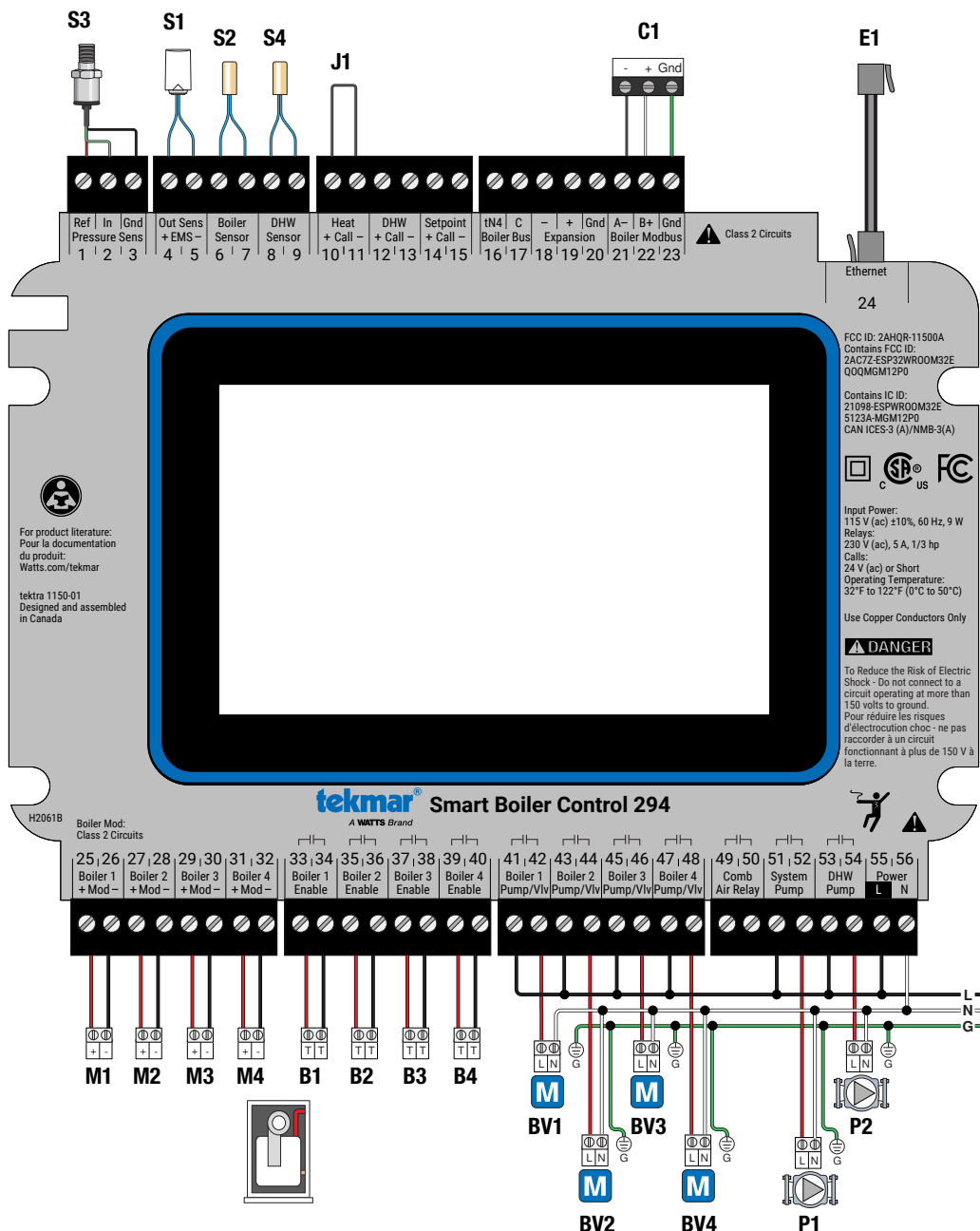

NOTICE

Boiler isolation valves must be spring return normally open. This permits boiler flow in the event of a loss of power.

Concept Drawing: This is only a concept drawing, not an engineered drawing. It is not intended to describe a complete system, nor any particular system. It is up to the system designer to determine the necessary components for and configuration of the particular system being designed, including additional equipment, isolation relays (for loads greater than the control's specified output ratings), and any safety devices which in the judgement of the designer are appropriate, in order to properly size, configure and design that system and to ensure compliance with building and safety code requirements.

Description

Four water heaters are operated to provide volume domestic hot water heating. A domestic hot water recirculation pump operates on a programmable schedule.

Features:

- Proportional staging with adjustable boiler and interstage differentials and time delays provide rapid response to domestic hot water heating loads.
- Equal run time rotation automatically balances the run time of the water heaters.
- Programmable schedule to reduces energy consumption during unoccupied time periods.
- Remote access from the Internet through the Nexa web or mobile applications.

Legend

S1 = DHW Tank Sensor 078

S2 = Pressure Sensor 088 (Optional)

P1...P4 = Water Heater Pumps

P5 = DHW Recirculation Pump

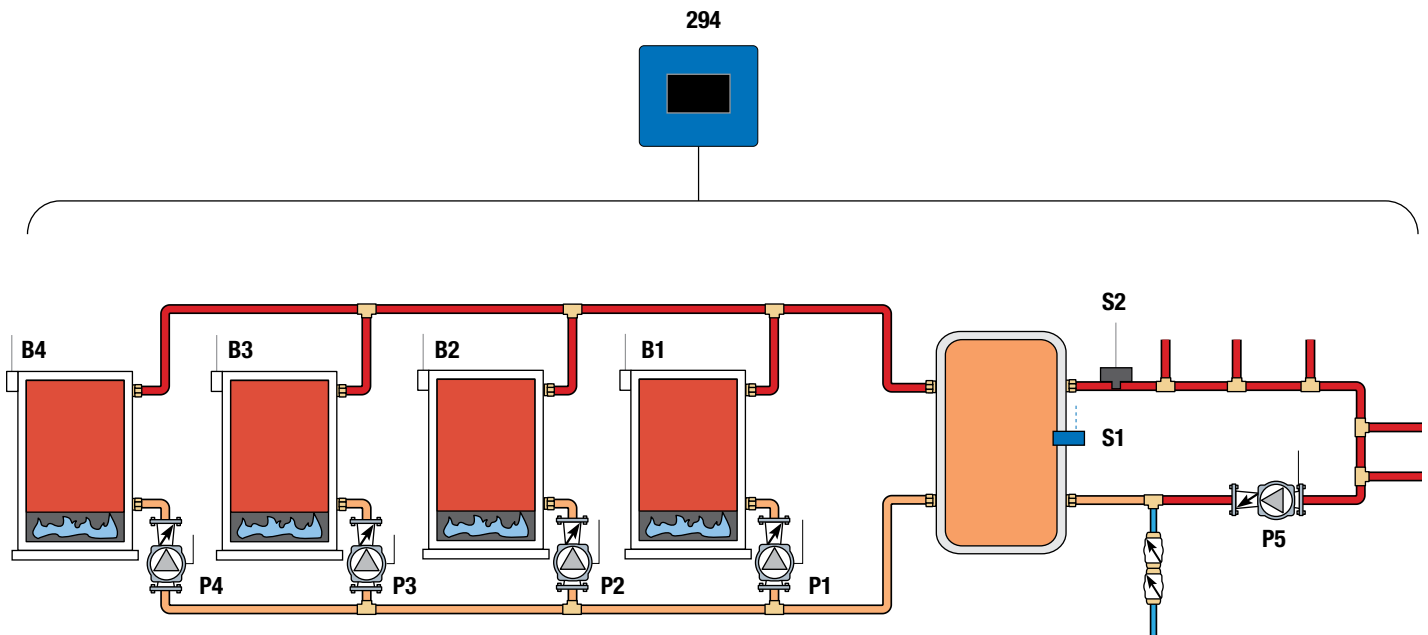

Concept Drawing: This is only a concept drawing, not an engineered drawing. It is not intended to describe a complete system, nor any particular system. It is up to the system designer to determine the necessary components for and configuration of the particular system being designed, including additional equipment, isolation relays (for loads greater than the control's specified output ratings), and any safety devices which in the judgement of the designer are appropriate, in order to properly size, configure and design that system and to ensure compliance with building and safety code requirements.

Legend

B1...B4 = Water Heater On-Off Enable 1 to 4

E1 = Ethernet (Optional)

M1...M4 = Water Heater Modulating Signal 1 to 4

S1 = DHW Tank Sensor 078

S2 = Pressure Sensor 088 (Optional)

P1...P4 = Water Heater Pumps

P5 = DHW Recirculation Pump

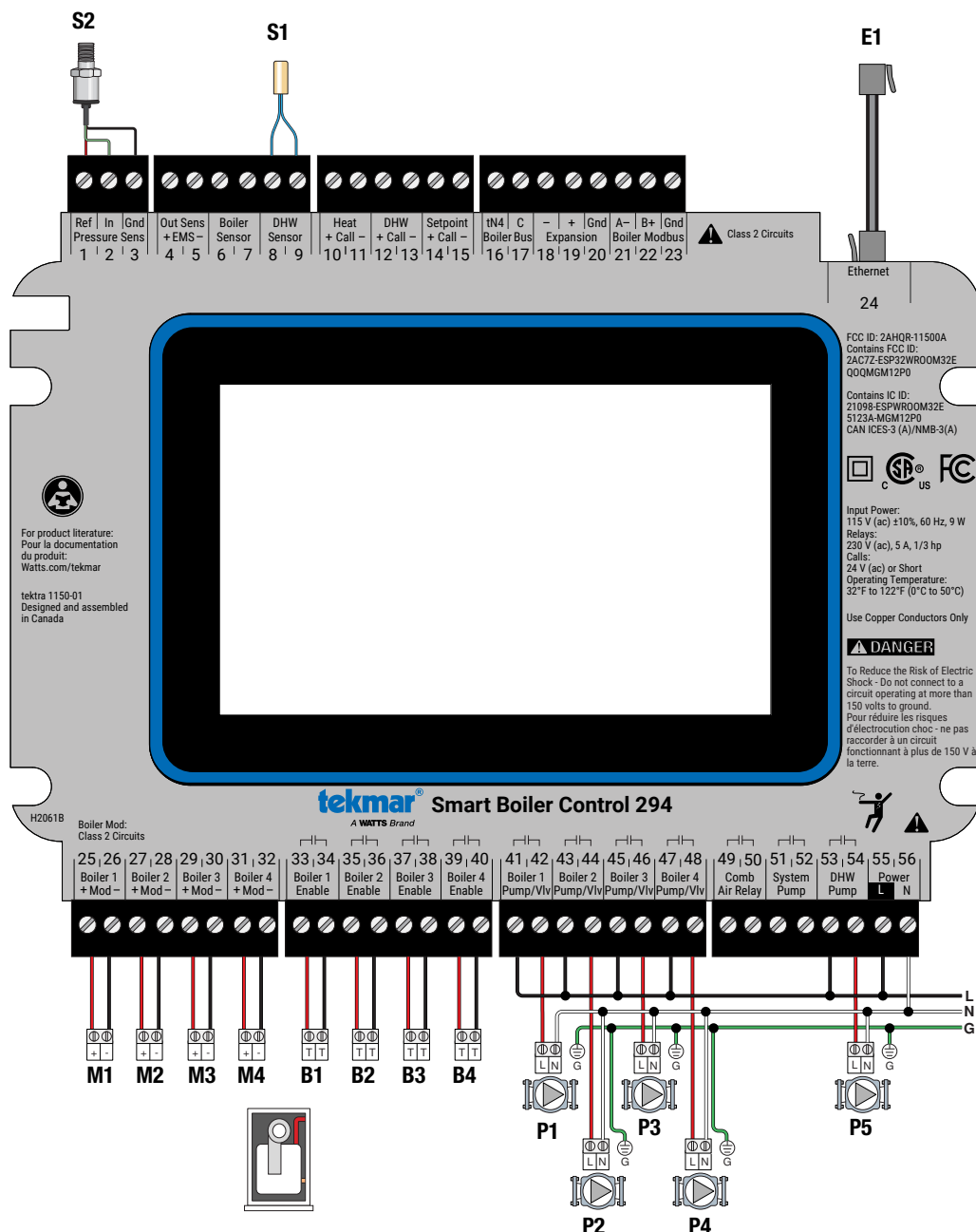

Concept Drawing: This is only a concept drawing, not an engineered drawing. It is not intended to describe a complete system, nor any particular system. It is up to the system designer to determine the necessary components and configuration of the particular system being designed, including additional equipment, isolation relays (for loads greater than the control's specified output ratings), and any safety devices which in the judgement of the designer are appropriate, in order to properly size, configure and design that system and to ensure compliance with building and safety code requirements.

Specifications

The following are the recommended specifications for the Smart Boiler Control 294

- The control shall be capable of sequencing up to four single-stage, two two-stage, one three-stage, one four-stage or four modulating boilers.
- The control shall be capable of operating modulating boilers using an analog 0 – 10 V(dc) or 4 – 20 mA signal.
- The control shall operate modulating boilers using an analog signal to change the boiler firing rate or the boiler target temperature.
- The control shall be capable of operating combinations of condensing and non-condensing boilers.
- The control shall be capable of adjusting the boiler plant target to provide indirect domestic hot water heating with priority.
- The control shall have the ability to calculate the boiler plant target temperature based on outdoor temperature reset.
- The control shall have the ability to calculate the boiler plant temperature based on the indoor temperature.
- The control shall have the ability to set the boiler plant target temperature using an adjustable setpoint.
- The control shall have the ability to set the boiler plant target temperature as directed by a BAS, BMS or EMS.
- The control shall have an adjustable warm weather shut down applied to outdoor temperature reset operation.
- The control shall be able to operate one primary pump and one domestic hot water pump during a domestic hot water call.
- The control shall have the option to measure fluid pressure.
- The control shall have an option to rotate the boilers based on the accumulated running hours.
- The control shall display the run time of the boilers.
- The control shall use proportional, integral and derivative (PID) logic when modulating or staging the boilers.
- The control shall have the option to modulate the boilers sequentially or in parallel.
- The control shall have an adjustable minimum supply water temperature setting to help prevent condensation of flue gases and subsequent corrosion and blockage of the boiler's heat exchanger and chimney.
- The control shall have the option of an automatic differential calculation in order to prevent short cycling of the boilers.
- The control shall have the option to have all of the boilers operate a pump or an isolation valve.
- The control shall have adjustable post purge settings that allow the primary and boiler pumps / valves to run for a set period after the boiler has been shut off.
- The control shall have the option for fixed lead and fixed last boiler rotation.
- The control shall have the option to operate a combustion air damper output.
- The control shall have an adjustable minimum inter-stage delay that can be set manually or calculated by the control.
- The control shall have the option of accepting a 0 – 10 V (dc) or 2 – 10 V (dc) input signal from an energy management system with an adjustable offset.
- The control shall have an optional passcode to prevent unauthorized access to the home screen and setting menus.
- The control shall have manual override options to test boiler and pump operation, suspend boiler plant operation, operate pumps for purging and operate the system with a maximum heat output.
- The control shall have the ability to display the current outdoor, boiler supply, domestic hot water temperatures.
- The control shall continually monitor the temperature and pressure sensors and provide an error message upon a control or sensor failure.
- During extended periods of inactivity, all pumps shall be periodically exercised to prevent seizure during long idle periods.
- The control shall include a setback schedule to provide energy savings during unoccupied time periods.
- The control shall have the option to operate as a tN4 system control with a tN4 boiler bus.
- The control shall display the current percent modulation of each boiler, or the number of stages fired.
- The control shall have the option to connect to the Internet using Ethernet or Wi-Fi.
- The control shall have the ability to automatically set the time and date from the Internet.
- The control shall have the ability to retrieve the local outdoor air temperature through the Internet.
- The control shall have the ability to be remotely monitored and adjust settings through a web and/or mobile application.



A WATTS Brand

All specifications are subject to change without notice

Tel: 1-800-438-3903 • Fax: (250) 984-0815
tekmarControls.com

