

## Installation Instructions

# Series CSM-82-F

Ductile Iron Static Balancing Valves

Sizes: 1¼" - 12"



4" CSM-82-F



2" CSM-82-F

## Important Safety Information



Do not open the valve while the system is pressurized. Doing so can cause severe injury. Begin work only after the system has been fully depressurized.



Components may be extremely hot. Allow the equipment to cool completely before starting any work to avoid burns or heat-related injuries.



Corrosive substances may be present. Wear appropriate protective equipment during disassembly to prevent chemical injuries.

### ⚠ WARNING



Please read carefully before proceeding with installation. Your failure to follow any attached instructions or operating parameters may lead to the product's failure.



Keep this Manual for future reference.

### ⚠ WARNING

Local building or plumbing codes may require modifications to the information provided. You are required to consult the local building and plumbing codes prior to installation. If the information provided here is not consistent with local building or plumbing codes, the local codes should be followed. This product must be installed by a licensed contractor in accordance with local codes and ordinances.

### NOTICE

Follow the guidelines listed here for proper installation, operation, and maintenance.

### ⚠ WARNING

Use caution when soldering. Protect yourself and others. FUMES AND GASES can be hazardous to your health. HEAT RAYS (INFRARED RADIATION) from flame or hot metal can injure eyes.

### NOTICE

Inquire with governing authorities for local installation requirements

## General Information

Watts Series CSM-82-F balancing valves are lubricated globe valves designed for applications requiring balancing on medium to large flow rates. The valve flanges are in accordance with ANSI B16.1 Class 125. Face to Face dimensions are in accordance with ANSI B16.10.

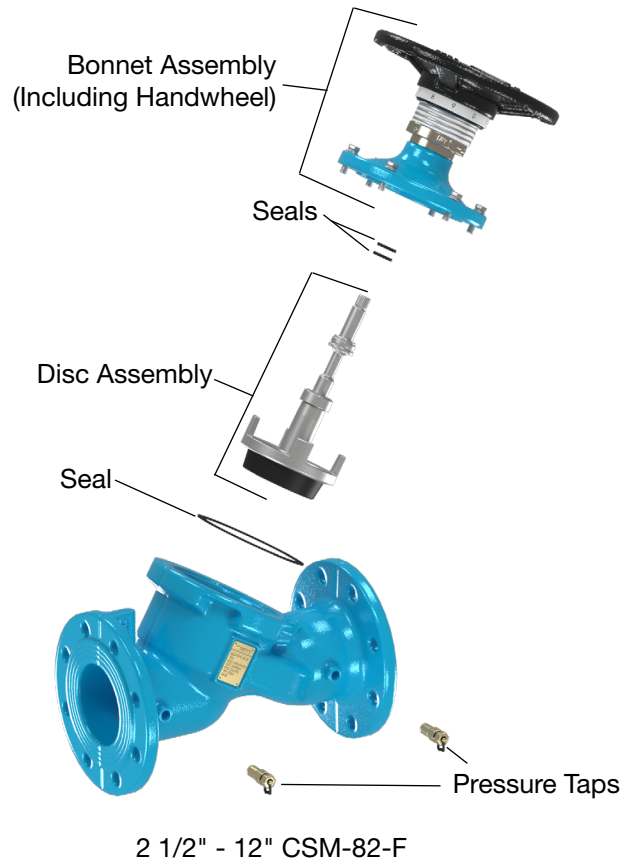
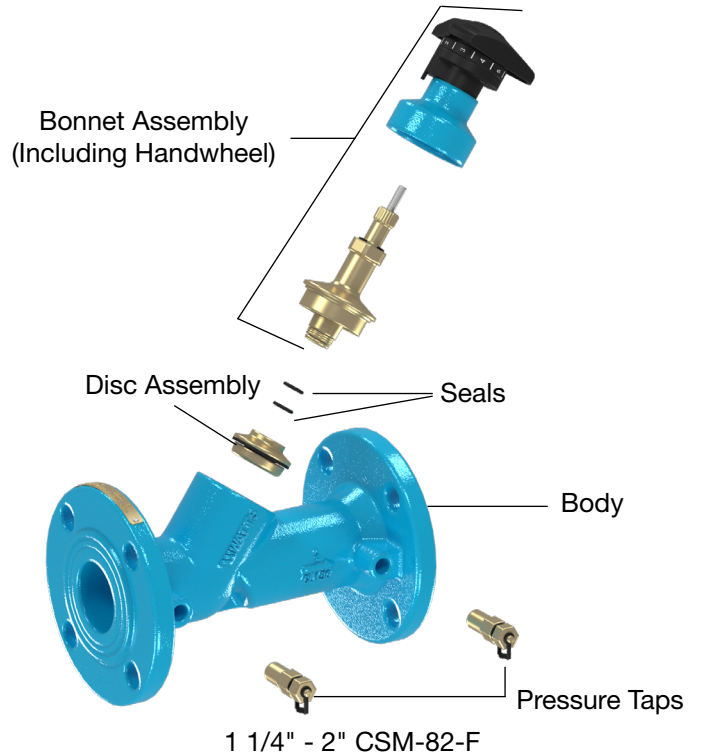

\* See Watts.com for available repair kits.

# Installation Instructions

## Pre-Installation

1. Inspect the valve to make sure there are no issues in the physical appearance of the valve. Install valve on return line of equipment to be balanced or as shown on the plans.

## Orientation

1. For maximum accuracy, the flow measurement/balancing valve should be located in an unrestricted straight pipe run so that no fittings (elbow, valve, tee, etc.) is closer to the flow measurement/balancing valve than 5 pipe diameters upstream and 2 pipe diameters downstream. If a balancing valve is located downstream from a circulation pump, allow a distance of ten (10) diameters between the pump and balancing valves.

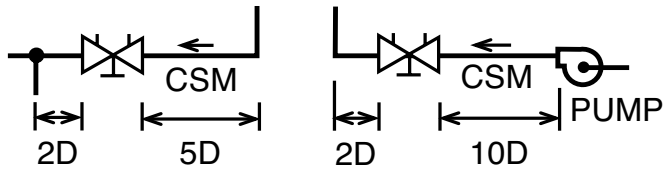

2. Install valve with the flow arrow (marked on body) in the same direction as the flow. The valve can be installed with the handwheel facing up or down.

## Installation

1. Install the gaskets between valve and pipe to ensure sealing. In case of end of line service, a blanking flange should be applied.
2. Install testing connectors: remove the plugs, CCW Wrap the valve parts with PTFE tape in 6-8 circles, and assemble and tighten the testing connectors (5-20 Nm torque is recommended).

## Installation

1. Turn the handwheel to adjust to the open position.
2. Connect vent and prepare the differential gauge. Refer to instructions furnished with the gauge.
3. After initial pressure differential reading is taken, refer to flow rate charts to obtain flow rate based on pressure differential and valve setting. If flow rate is in excess of that specified, turn indicator towards closed position, noting pressure drop and valve setting and determining new flow rates from flow rate chart. The unit or system has now been balanced.
4. Disconnect differential gauge.

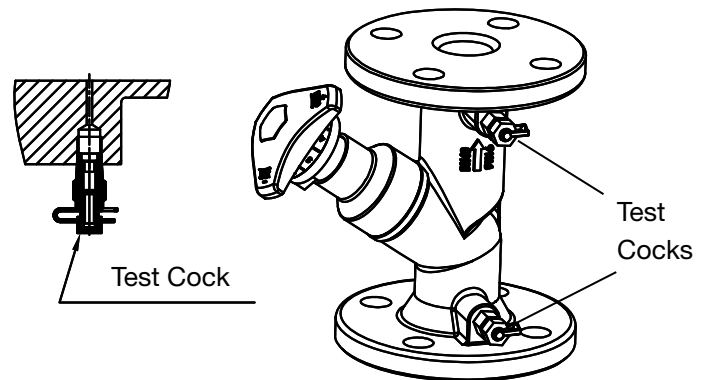
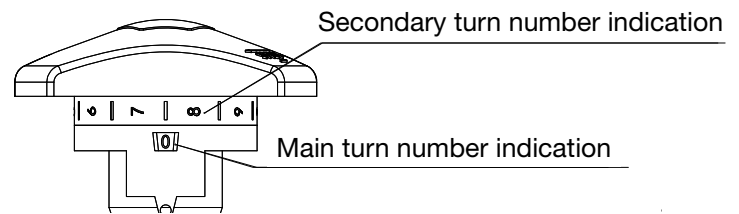

1 1/4" - 2" CSM-82-F

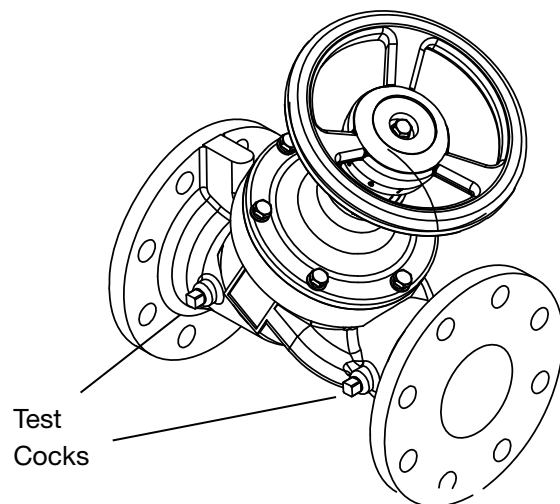

2 1/2" - 12" CSM-82-F

# Dimensions

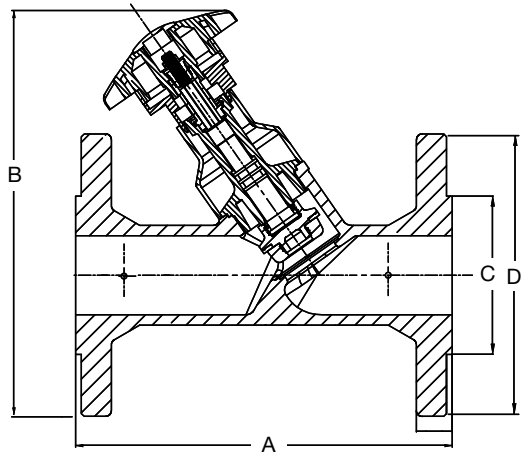

1 1/4" - 2" CSM-82-F

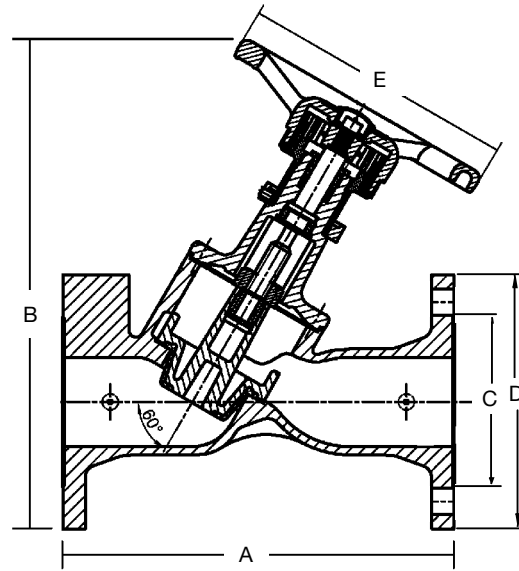

2 1/2" - 12" CSM-82-F

MODEL	SIZE	DIMENSIONS										WEIGHT	
		A		B		C		D		E		lbs.	kgs.
	<i>in.</i>	<i>in.</i>	<i>mm</i>	<i>in.</i>	<i>mm</i>	<i>in.</i>	<i>mm</i>	<i>in.</i>	<i>mm</i>	<i>in.</i>	<i>mm</i>		
CSM-82-F	1¼	7	180	7.26	184.5	4.61	117	4 <sup>5</sup> / <sub>8</sub>	117	-	-	10.0	4.5
	1½	7.87	200	2.91	74	5.00	127	5	127	-	-	12.4	5.6
	2	9.06	230	8.54	217	5.98	152	5 <sup>7</sup> / <sub>8</sub>	152	-	-	15.7	7.1
	2½	11.42	290	13.90	353	7.09	180	7 <sup>1</sup> / <sub>16</sub>	180	7.87	200	36.1	16.4
	3	12.20	310	14.29	363	7.48	190	7 <sup>1</sup> / <sub>2</sub>	190	7.87	200	43.5	19.7
	4	13.78	350	16.34	415	9.06	230	10 <sup>1</sup> / <sub>16</sub>	255	9.45	240	59.4	27.0
	6	18.90	480	18.90	480	11.02	280	11	280	11.42	290	98.9	44.8
	8	23.62	600	27.46	697.5	13.58	345	13 <sup>9</sup> / <sub>16</sub>	345	13.78	350	209.0	94.8
	10	28.74	730	30.49	774.5	15.94	405	15 <sup>15</sup> / <sub>16</sub>	405	16.54	420	40.6	182.6
	12	33.46	850	36.56	928.5	19.09	485	19 <sup>1</sup> / <sub>8</sub>	485	16.54	420	534.6	242.5

Suffix: F = Flanged Ends

# 1 1/4" CSM-82-F Flow Curve

## Cross Handle Setting (Number of Turns)

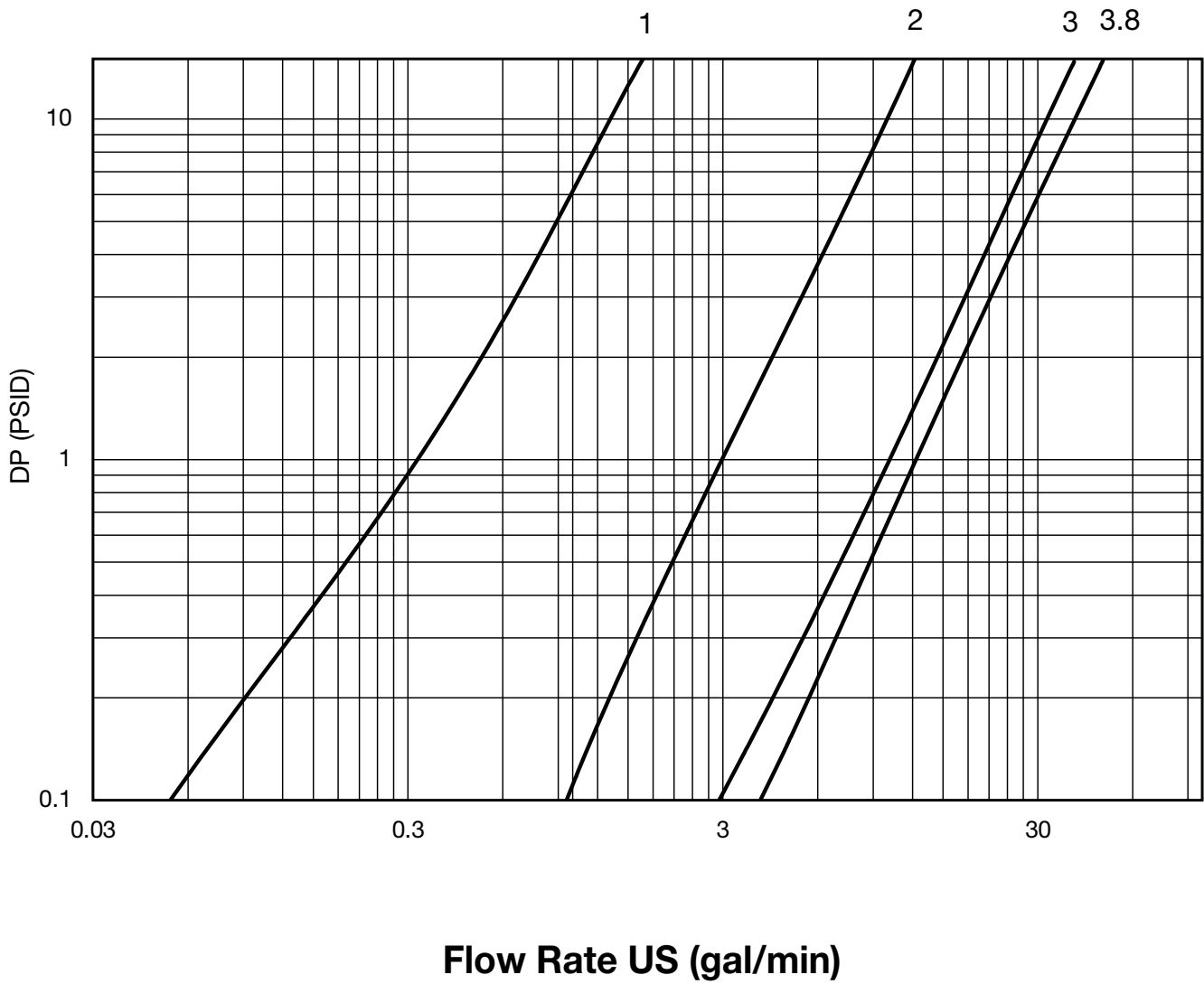

HANDWHEEL POSITION	1	2	3	FULL OPEN
1 1/4"	0.28	2.93	10.02	12.22

# 1 1/2" CSM-82-F Flow Curve

## Cross Handle Setting (Number of Turns)

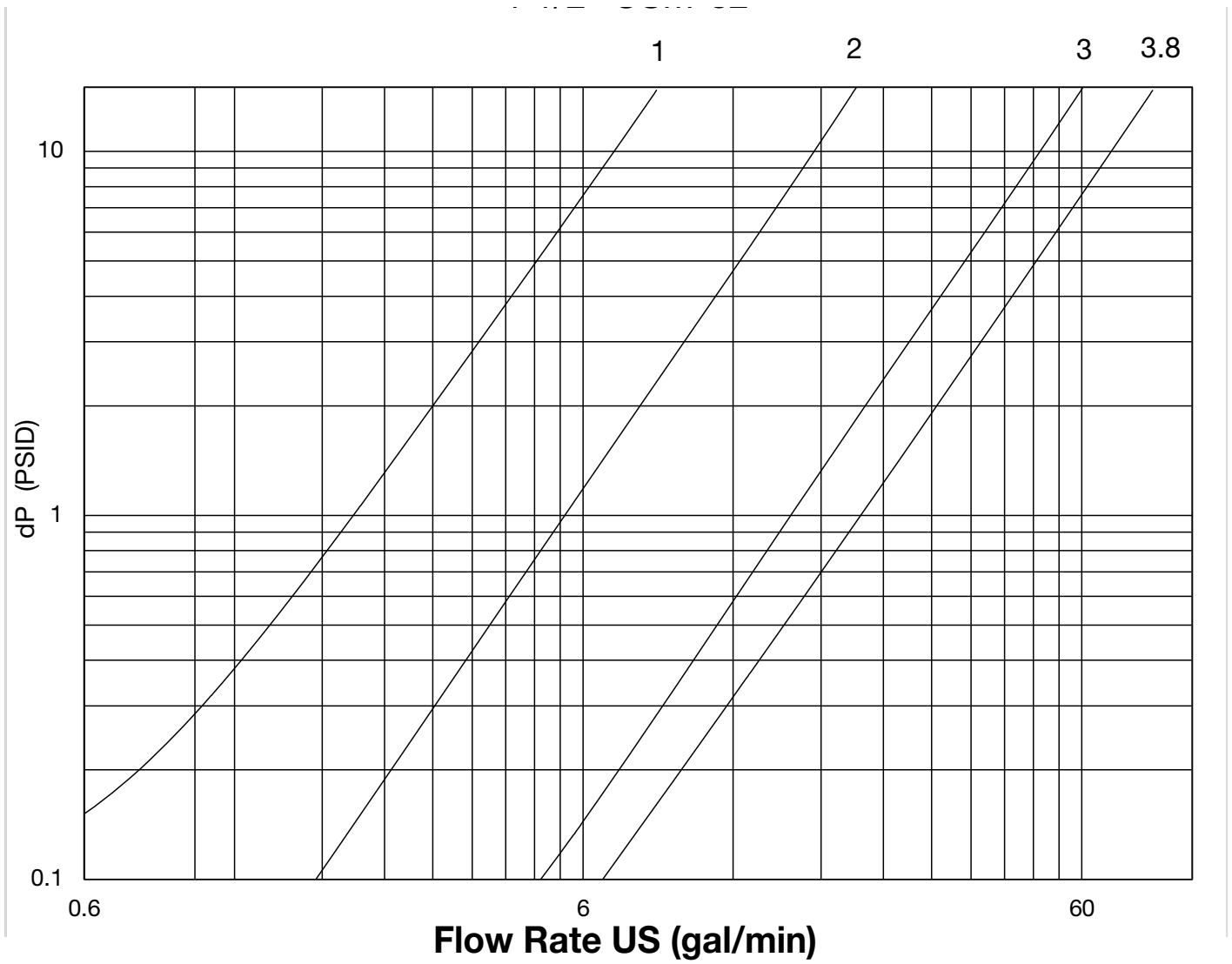

HANDWHEEL POSITION	1	2	3	FULL OPEN
1 1/2"	2.03	5.41	15.60	21.47

# 2" CSM-82-F Flow Curve

## Cross Handle Setting (Number of Turns)

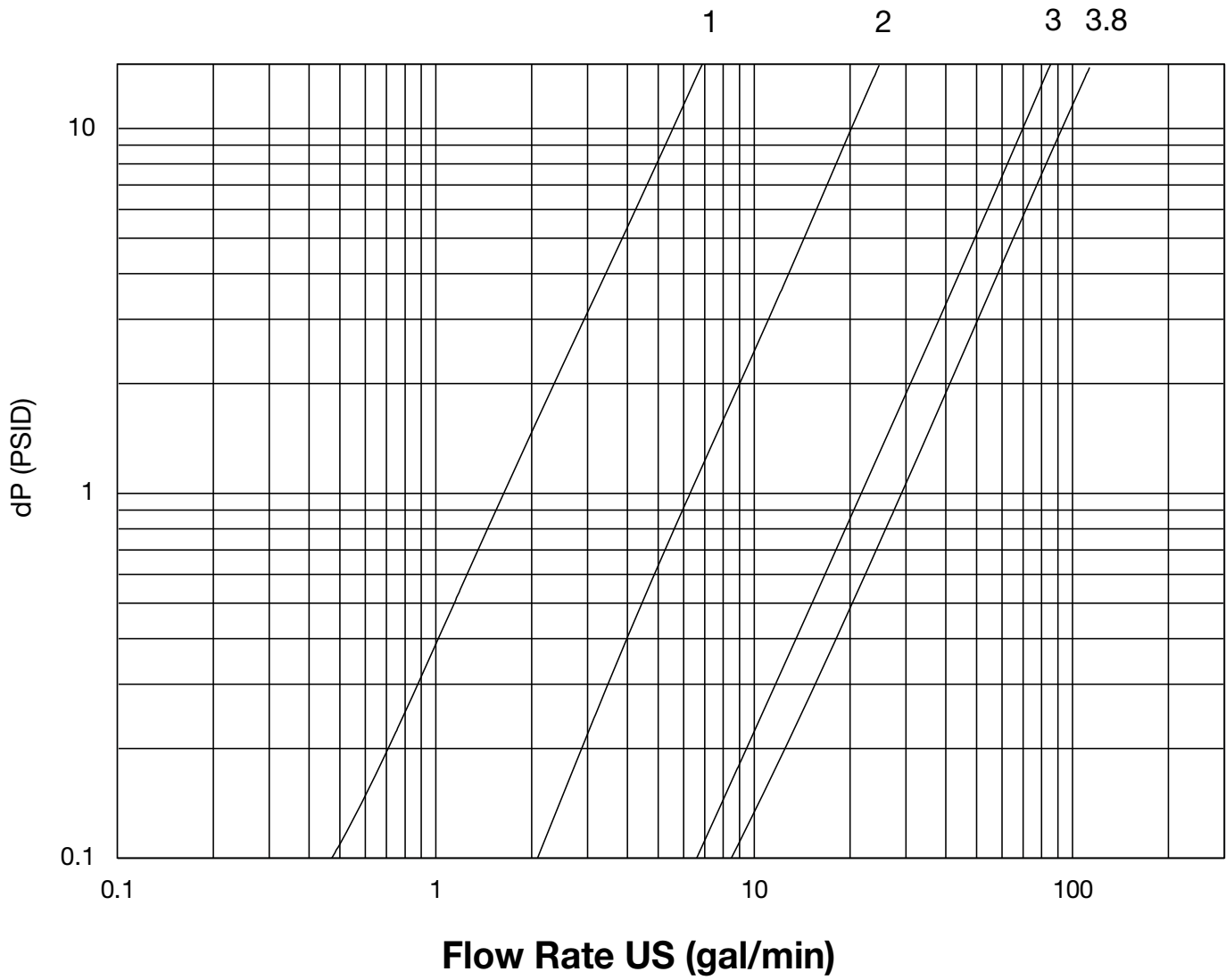

HANDWHEEL POSITION	1	2	3	FULL OPEN
2"	1.50	6.26	21.86	29.00

# 2 1/2" CSM-82-F Flow Curve

## Handwheel Setting (Number of Turns)

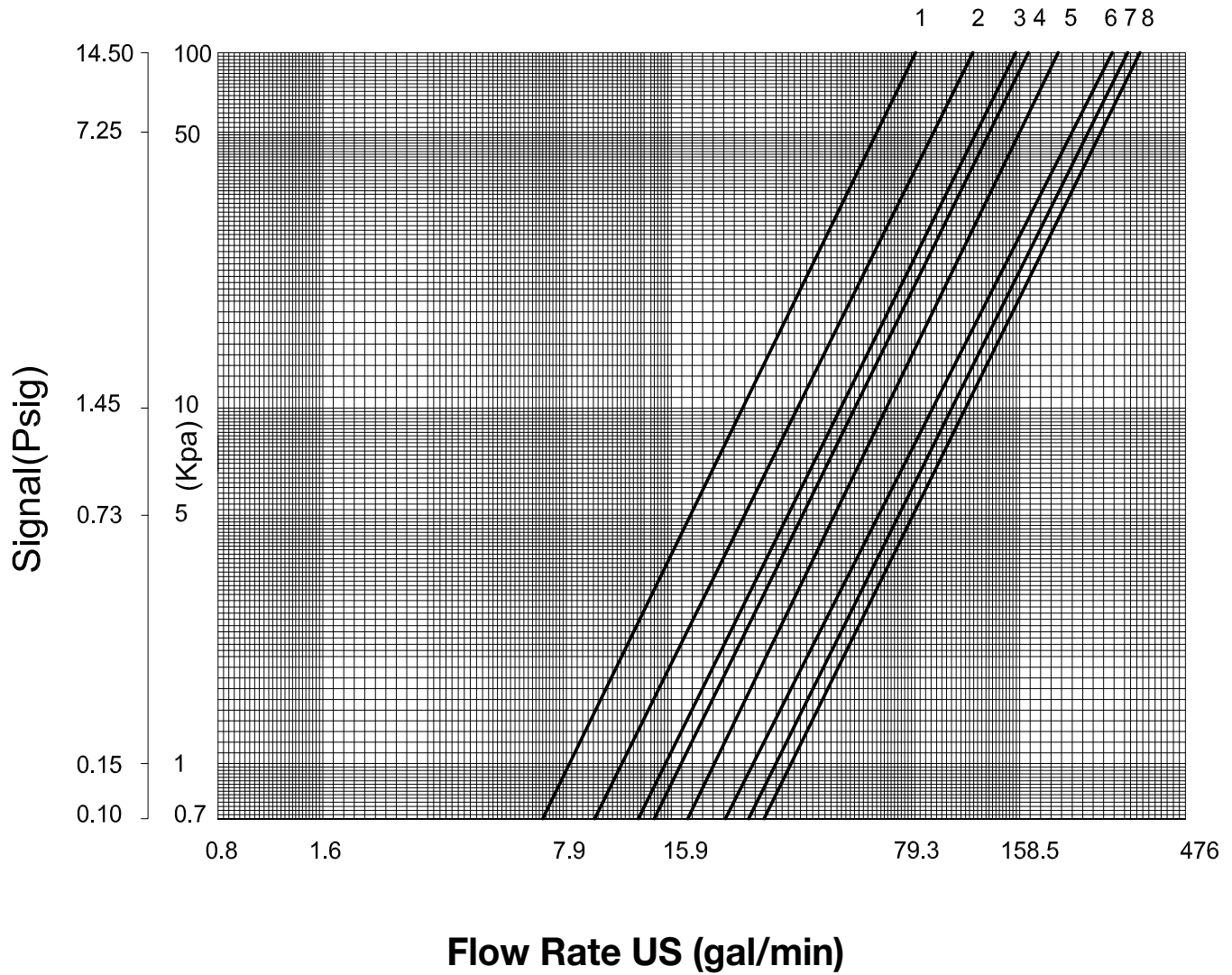

HANDWHEEL POSITION	1	2	3	4	5	6	7	8	FULL OPEN
2½"	21.50	30.98	40.92	44.74	57.11	75.72	86.24	92.71	96.87

# 3" CSM-82-F Flow Curve

## Handwheel Setting (Number of Turns)

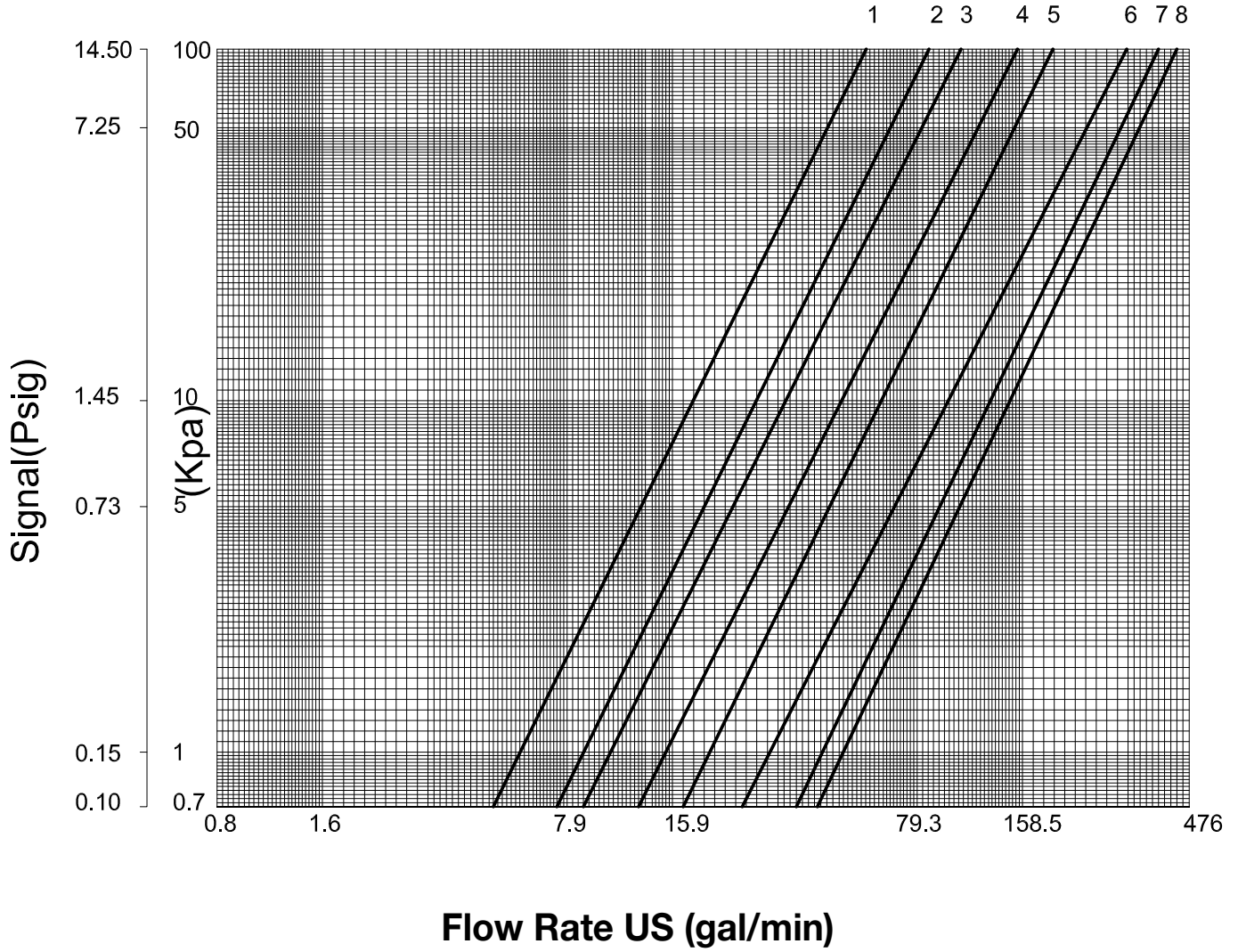

HANDWHEEL POSITION	1	2	3	4	5	6	7	8	FULL OPEN
3"	15.37	23.12	27.86	40.34	53.06	82.77	114.21	131.44	138.14

# 4" CSM-82-F Flow Curve

## Handwheel Setting (Number of Turns)

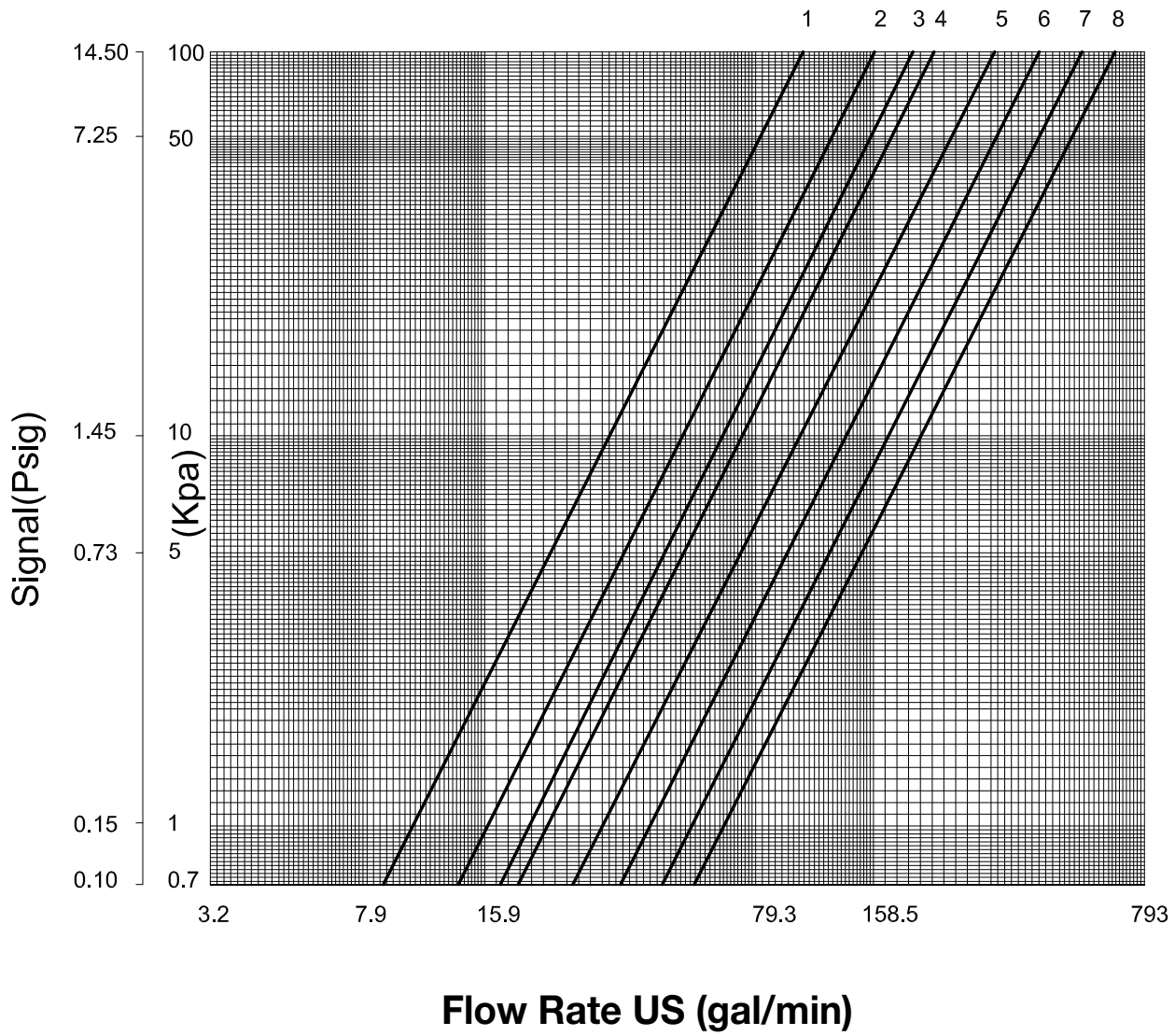

HANDWHEEL POSITION	1	2	3	4	5	6	7	8	FULL OPEN
4"	27.28	42.31	56.07	63.81	86.93	113.17	143.23	172.71	206.58

# 6" CSM-82-F Flow Curve

## Handwheel Setting (Number of Turns)

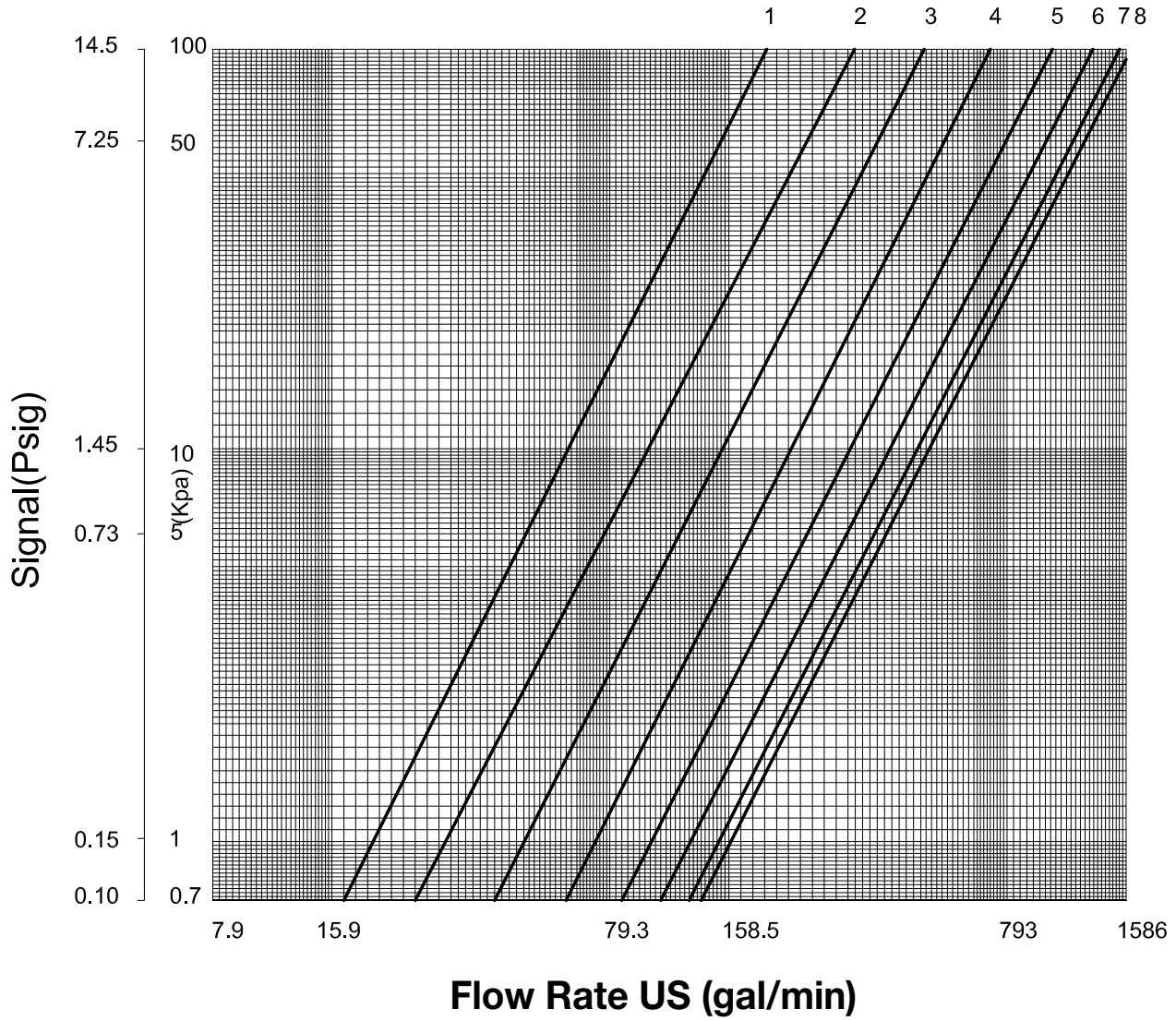

HANDWHEEL POSITION	1	2	3	4	5	6	7	8	FULL OPEN
6"	55.49	86.70	127.16	187.27	269.35	339.86	399.98	428.88	439.28

# 8" CSM-82-F Flow Curve

## Handwheel Setting (Number of Turns)

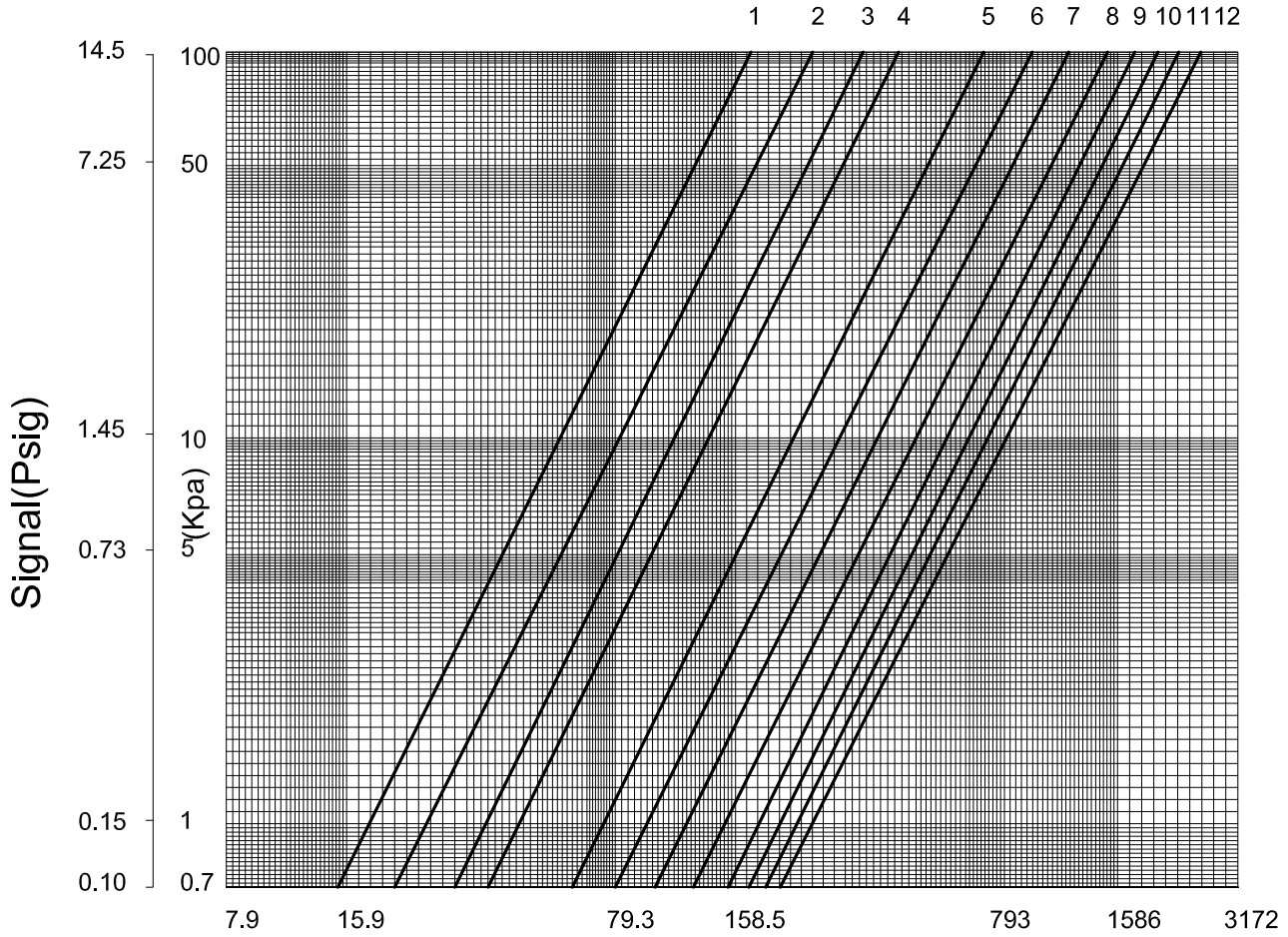

## Flow Rate US (gal/min)

HANDWHEEL POSITION	1	2	3	4	5	6	7	8	9	10	11	12	FULL OPEN
8"	47.40	70.52	93.64	114.44	186.12	248.54	313.28	391.88	476.27	557.19	631.18	-	702.85

# 10" CSM-82-F Flow Curve

## Handwheel Setting (Number of Turns)

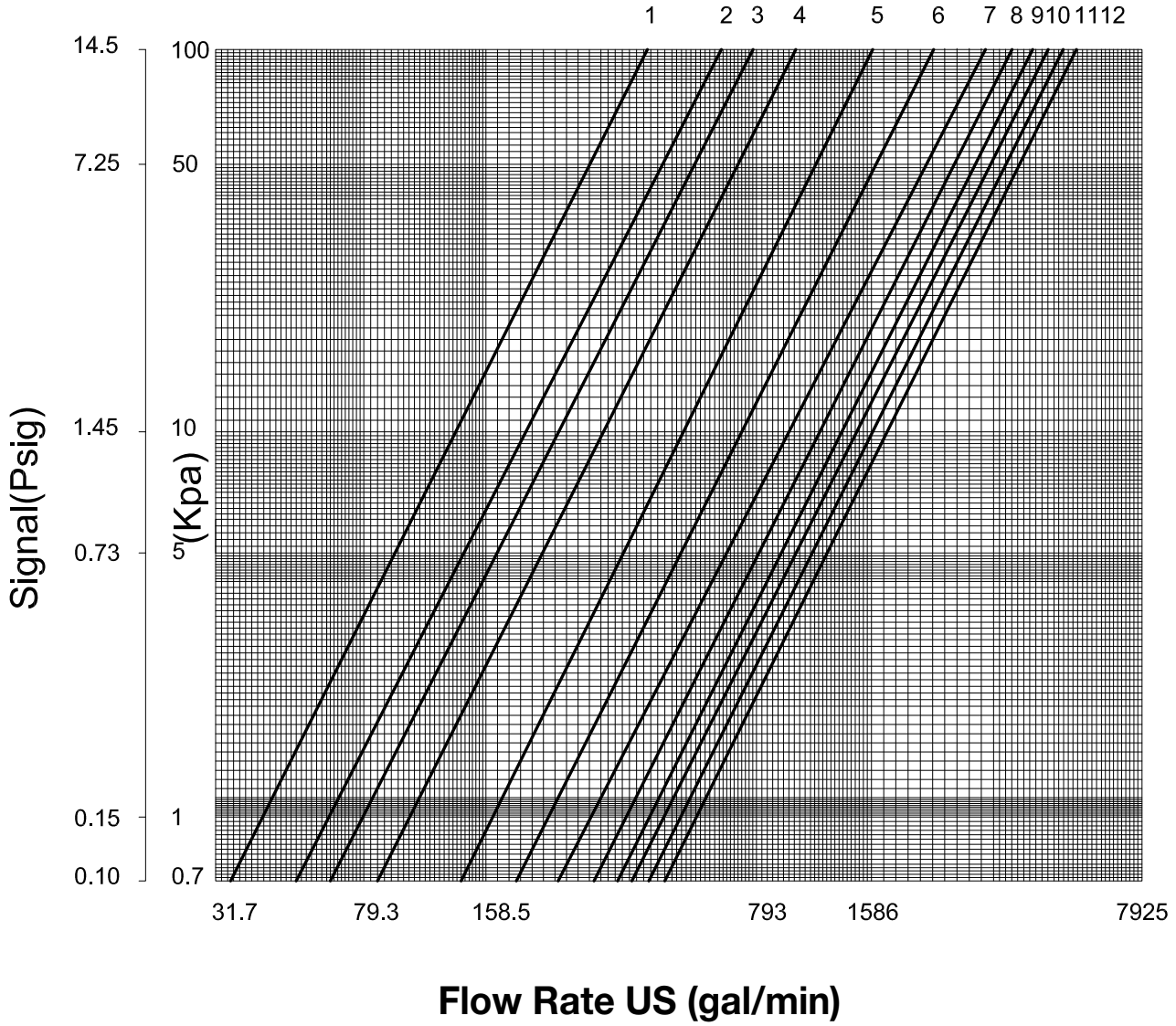

HANDWHEEL POSITION	1	2	3	4	5	6	7	8	9	10	11	12	FULL OPEN
10"	112.13	168.78	204.61	268.19	425.41	627.71	803.42	961.79	1109.76	1208.02	1330.56	1443.84	1493.55

# 12" CSM-82-F Flow Curve

## Handwheel Setting (Number of Turns)

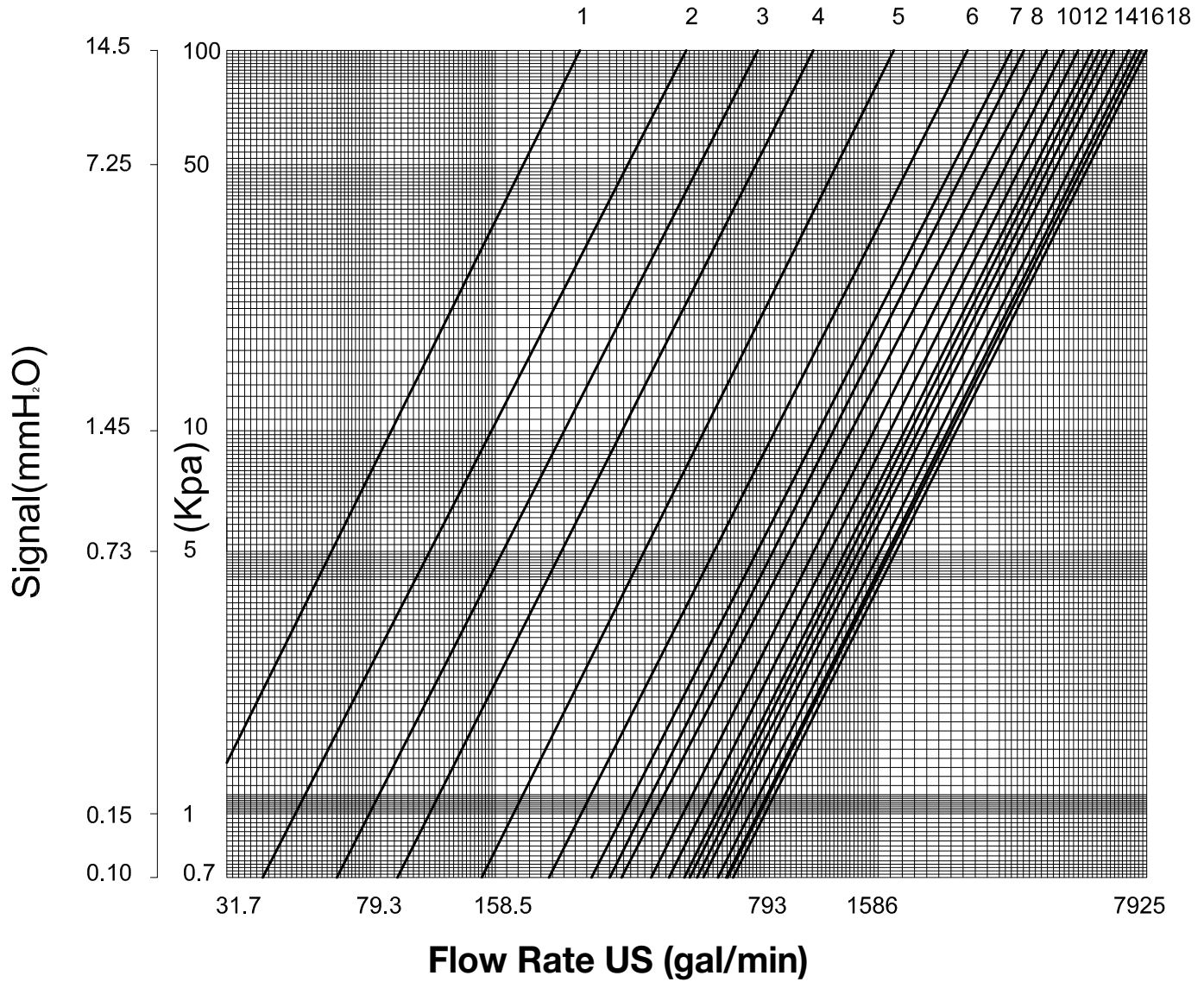

HANDWHEEL POSITION	1	2	3	4	5	6	7	8	9	10	11	12
12"	72.83	130.63	201.14	283.22	458.93	725.97	915.55	1009.19	1158.31	1285.47	1413.79	1538.64

HANDWHEEL POSITION	13	14	15	16	17	18	FULL OPEN
12"	1598.75	1669.26	1739.78	1894.68	1973.29	1999.88	2070.40

Watts Regulator Co. (the "Company") warrants each product to be free from defects in material and workmanship under normal usage for a period of one year from the date of original shipment. In the event of such defects within the warranty period, the Company will, at its option, replace or recondition the product without charge.

**THE WARRANTY SET FORTH HEREIN IS GIVEN EXPRESSLY AND IS THE ONLY WARRANTY GIVEN BY THE COMPANY WITH RESPECT TO THE PRODUCT. THE COMPANY MAKES NO OTHER WARRANTIES, EXPRESS OR IMPLIED. THE COMPANY HEREBY SPECIFICALLY DISCLAIMS ALL OTHER WARRANTIES, EXPRESS OR IMPLIED, INCLUDING BUT NOT LIMITED TO THE IMPLIED WARRANTIES OF MERCHANTABILITY AND FITNESS FOR A PARTICULAR PURPOSE.**

The remedy described in the first paragraph of this warranty shall constitute the sole and exclusive remedy for breach of warranty, and the Company shall not be responsible for any incidental, special or consequential damages, including without limitation, lost profits or the cost of repairing or replacing other property which is damaged if this product does not work properly, other costs resulting from labor charges, delays, vandalism, negligence, fouling caused by foreign material, damage from adverse water conditions, chemical, or any other circumstances over which the Company has no control, including without limitation the use of incompatible chemicals and lubricants. This warranty shall be invalidated by any abuse, misuse, misapplication, improper installation or improper maintenance or alteration of the product, as well as any failure to install, operate or maintain the product in strict accordance and adherence with the product's operating documentation and manuals.

Some States do not allow limitations on how long an implied warranty lasts, and some States do not allow the exclusion or limitation of incidental or consequential damages. Therefore the above limitations may not apply to you. This Limited Warranty gives you specific legal rights, and you may have other rights that vary from State to State. You should consult applicable state laws to determine your rights. **SO FAR AS IS CONSISTENT WITH APPLICABLE STATE LAW, ANY IMPLIED WARRANTIES THAT MAY NOT BE DISCLAIMED, INCLUDING THE IMPLIED WARRANTIES OF MERCHANTABILITY AND FITNESS FOR A PARTICULAR PURPOSE, ARE LIMITED IN DURATION TO ONE YEAR FROM THE DATE OF ORIGINAL SHIPMENT.**



USA: T: (978) 689-6066 • Watts.com

Canada: T: (888) 208-8927 • Watts.ca

Latin America: T: (52) 55-4122-0138 • Watts.com

