

Mechanical

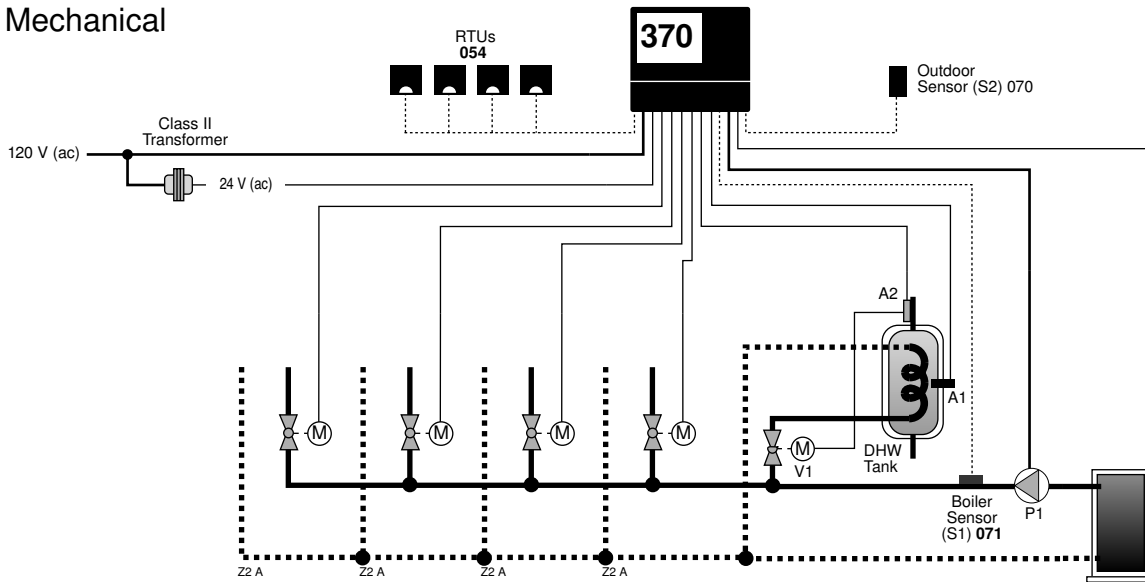

Electrical

- A1 = DHW Aquastat
- A2 = DHW High Limit Aquastat
- P1 = System Pump
- S1 = Boiler Sensor 071
- S2 = Outdoor Sensor 070
- U1 = tekmar Timer 031 (optional)
- V1 = On/Off Spring Return Zone Valve

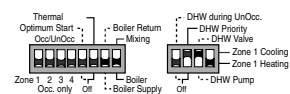

- = Required
- = Optional

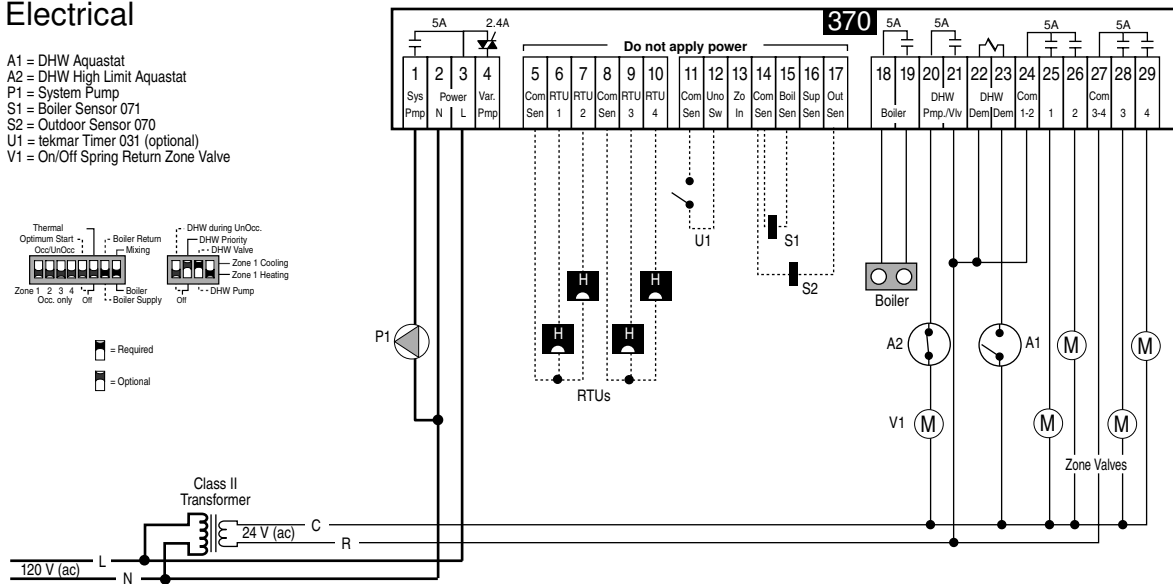

Note: This is only a concept drawing. The designer must determine whether this application will work in his system and must ensure compliance with code requirements. Necessary auxiliary equipment, isolation relays (for loads greater than the specified tekmar internal relay ratings), and other safety and limit devices must be added.

Access Levels

House Control 370 Four Zones, DHW, Boiler / Mixing

Literature	— D 370, A 370's, D 001, D 070, E 021.
Control	— Microprocessor PID control; This is not a safety (limit) control.
Packaged Weight	— 3.5 lb. (1600 g), Enclosure A, blue PVC plastic
Dimensions	— 6-5/8" H x 7-9/16" W x 2-13/16" D (170 x 193 x 72 mm)
Approvals	— CSA NRTL /C, meets ICES & FCC regulations for EMI/RFI.
Ambient conditions	— Indoor use only, 32 to 122°F (0 to 50°C), <90% RH non-condensing.
Power supply	— 120 V (ac) ±10% 50/60 Hz 1000 VA
Var. Pump	— 240 V (ac) 50/60 Hz 2.4 A 1/6 hp, fuse T2.5 A 250 V
Relays	— 120 V (ac) 5 A 1/3 hp, pilot duty 240 VA
Demands	— 24 to 120 V (ac) 2 VA
Sensors included	— NTC thermistor, 10 kΩ @ 77°F (25°C ±0.2°C) β=3892
	— Outdoor Sensor 070 and 2 of Universal Sensor 071
required:	— RTU 054 or 055. (Ordered Separately)
Optional devices	— tekmar type #: 031, 367, 368.

Heating Curve	— 0.2 to 3.6
Max. System Supply	— 120 to 220°F (49 to 104°C)
Min. Boiler Supply	— Off, 100 to 165°F (Off, 38 to 74°C)

Timer	— 24 hour, 1 event / day, 3 minute backup
UnOcc. Duration	— 0 to 24 hours
Unoccupied	— 40 to 100°F (4 to 38°C)

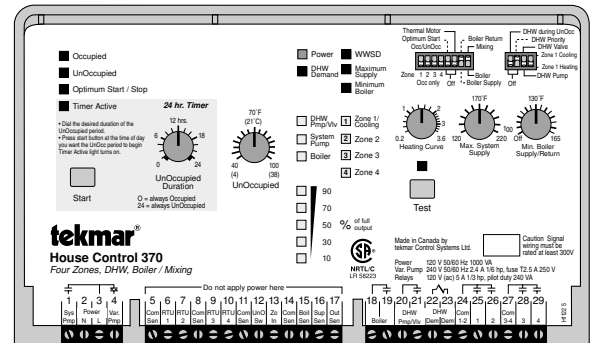

System Operation & Specifications

The House Control 370 controls the space temperature of four heating zones. The required supply water temperature to the zones is controlled by operating a boiler. The 370 also controls the supply of heat to a DHW tank.

Piping and Heat Source Details The system is plumbed with zone valves and a system pump. Either a high mass, low mass or a condensing boiler can be used with this application. Heat is supplied to the DHW tank through a DHW valve (V1).

Warm Weather Shut Down (WWSHD) When the outdoor temperature rises above the highest RTU dial setting and the heating zones are satisfied, the 370 shuts down the heating system. The DHW system does, however, continue to operate.

Boiler Operation The 370 uses an outdoor reset strategy together with indoor temperature feedback from the RTUs to adjust the system supply water temperature. When heat is required in the zones, the 370 turns on the system pump (P1). In order to maximize boiler efficiency, the 370 operates the boiler at the lowest possible water temperature. The 370 automatically adjusts the boiler differential to prevent the boiler from short cycling.

Domestic Hot Water (DHW) When the DHW aquastat (A1) calls for heat, the 370 turns on the system pump (P1), opens the DHW valve (V1) and raises the boiler water temperature to at least 180°F (82°C). If *DHW Priority* is chosen, the 370 turns off the zone valves. Once the DHW demand is removed the 370 either performs a DHW Post Purge or a DHW Mixing Purge depending on whether or not the zones require heat.

Zoning Operation The 370 varies the on time of each zone valve based on a 15 minute cycle. The control staggers the operating times of the zones in order to achieve a steady load on the boiler and prevent boiler short cycling.

UnOccupied (Night Setback) Selected zones can be switched into an UnOccupied (Night Setback) mode through either the built-in 24 hr. Timer or by closing an external UnOccupied switch (U1). When the control is switched into UnOccupied mode, an UnOccupied dial is used to set the desired indoor temperature. An Optimum Start / Stop feature can be used to ensure the zones are returned to their Occupied temperatures as the UnOccupied period ends.

Other features Additional control features are listed in the table in the Heating Controls section of the Product Catalog I 000.



tekmar Control Systems Ltd., Canada
 tekmar Control Systems, Inc., U.S.A.
Head Office: 5100 Silver Star Road
Vernon, B.C. Canada V1B 3K4
Tel. (250) 545-7749 Fax. (250) 545-0650
Web Site: www.tekmarcontrols.com

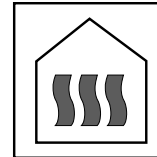

Mechanical

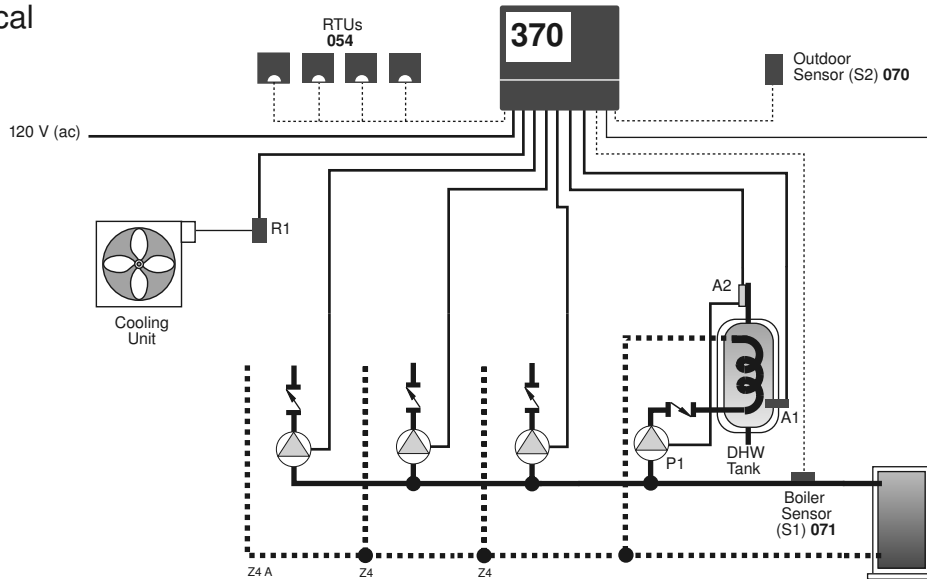

Electrical

- A1 = DHW Aquastat
- A2 = DHW High Limit Aquastat
- P1 = DHW Pump
- R1 = Relay 004
- S1 = Boiler Sensor 071
- S2 = Outdoor Sensor 070
- U1 = tekmar Timer 031 (optional)

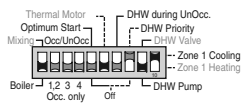

- = Required
- = Optional

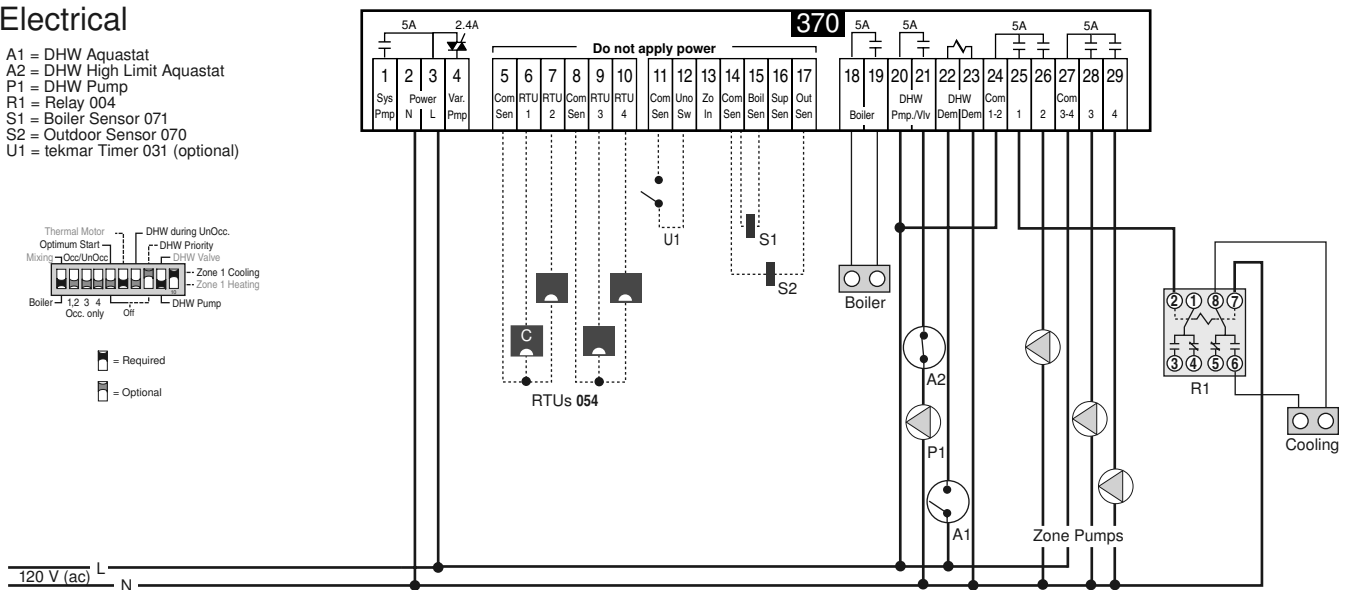

Note: This is only a concept drawing. The designer must determine whether this application will work in his system and must ensure compliance with code requirements. Necessary auxiliary equipment, isolation relays (for loads greater than the specified tekmar internal relay ratings), and other safety and limit devices must be added.

Access Levels

House Control 370 Four Zones, DHW, Boiler / Mixing

- Literature — D 370, A 370's, D 001, D 070, E 021.
- Control — Microprocessor PID control; **This is not a safety (limit) control.**
- Packaged Weight — 3.5 lb. (1600 g), Enclosure A, blue PVC plastic
- Dimensions — 6-5/8" H x 7-9/16" W x 2-13/16" D (170 x 193 x 72 mm)
- Approvals — CSA NRTL /C, meets ICES & FCC regulations for EMI/RFI.
- Ambient conditions — Indoor use only, 32 to 122°F (0 to 50°C), <90% RH non-condensing.
- Power supply — 120 V (ac) ±10% 50/60 Hz 1000 VA
- Var. Pump — 240 V (ac) 50/60 Hz 2.4 A 1/6 hp, fuse T2.5 A 250 V
- Relays — 120 V (ac) 5 A 1/3 hp, pilot duty 240 VA
- Demands — 24 to 120 V (ac) 2 VA
- Sensors included — NTC thermistor, 10 kΩ @ 77°F (25°C ±0.2°C) β=3892
- Outdoor Sensor 070 and 2 of Universal Sensor 071
- RTU 054 or 055. (Ordered Separately)
- Optional devices — tekmar type #: 031, 367, 368.
- Timer — 24 hour, 1 event / day, 3 minute backup
- UnOcc. Duration — 0 to 24 hours
- Unoccupied — 40 to 100°F (4 to 38°C)

- Heating Curve — 0.2 to 3.6
- Max. System Supply — 120 to 220°F (49 to 104°C)
- Min. Boiler Supply — Off, 100 to 165°F (Off, 38 to 74°C)

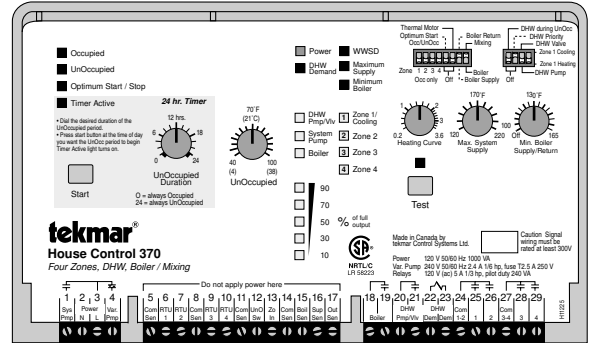

System Operation & Specifications

The House Control 370 controls the space temperature of four heating zones. The required supply water temperature to the zones is controlled by operating a boiler. The 370 also controls the supply of heat to a DHW tank.

Piping and Heat Source Details The system is plumbed with zone valves and a system pump. Either a high mass, low mass or a condensing boiler can be used with this application. Heat is supplied to the DHW tank through a DHW valve (V1).

Warm Weather Shut Down (WWSD) When the outdoor temperature rises above the highest RTU dial setting and the heating zones are satisfied, the 370 shuts down the heating system. The DHW system does, however, continue to operate.

Boiler Operation The 370 uses an outdoor reset strategy together with indoor temperature feedback from the RTUs to adjust the system supply water temperature. When heat is required in the zones, the 370 turns on the system pump (P1). In order to maximize boiler efficiency, the 370 operates the boiler at the lowest possible water temperature. The 370 automatically adjusts the boiler differential to prevent the boiler from short cycling.

Domestic Hot Water (DHW) When the DHW aquastat (A1) calls for heat, the 370 turns on the system pump (P1), opens the DHW valve (V1) and raises the boiler water temperature to at least 180°F (82°C). If *DHW Priority* is chosen, the 370 turns off the zone valves. Once the DHW demand is removed the 370 either performs a DHW Post Purge or a DHW Mixing Purge depending on whether or not the zones require heat.

Zoning Operation The 370 varies the on time of each zone valve based on a 15 minute cycle. The control staggers the operating times of the zones in order to achieve a steady load on the boiler and prevent boiler short cycling.

UnOccupied (Night Setback) Selected zones can be switched into an UnOccupied (Night Setback) mode through either the built-in 24 hr. Timer or by closing an external UnOccupied switch (U1). When the control is switched into UnOccupied mode, an UnOccupied dial is used to set the desired indoor temperature. An Optimum Start / Stop feature can be used to ensure the zones are returned to their Occupied temperatures as the UnOccupied period ends.

Other features Additional control features are listed in the table in the Heating Controls section of the Product Catalog I 000.

	<p>tekmar Control Systems Ltd., Canada tekmar Control Systems, Inc., U.S.A. Head Office: 5100 Silver Star Road Vernon, B.C. Canada V1B 3K4 Tel. (250) 545-7749 Fax. (250) 545-0650 Web Site: www.tekmarcontrols.com</p>
---	--

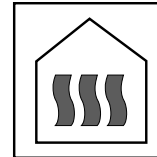

Mechanical

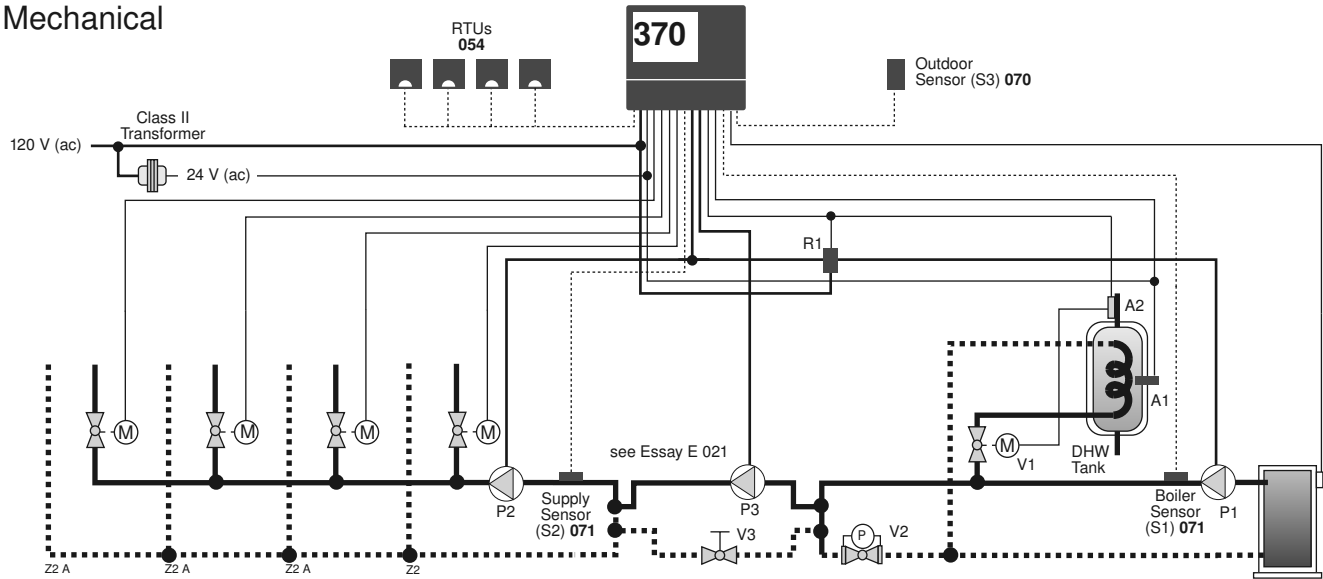

Electrical

- A1 = DHW Aquastat
- A2 = DHW High Limit Aquastat
- P1 = Primary Pump
- P2 = System Pump
- P3 = Variable Speed Injection Pump
- R1 = Relay 003
- S1 = Boiler Sensor 071
- S2 = Supply Sensor 071
- S3 = Outdoor Sensor 070
- V1 = On/Off Spring Return Zone Valve
- V2 = Pressure Bypass Valve, or Balancing Valve, or Globe Valve
- V3 = Balancing Valve or Globe Valve

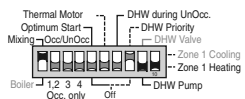

- = Required
- = Optional

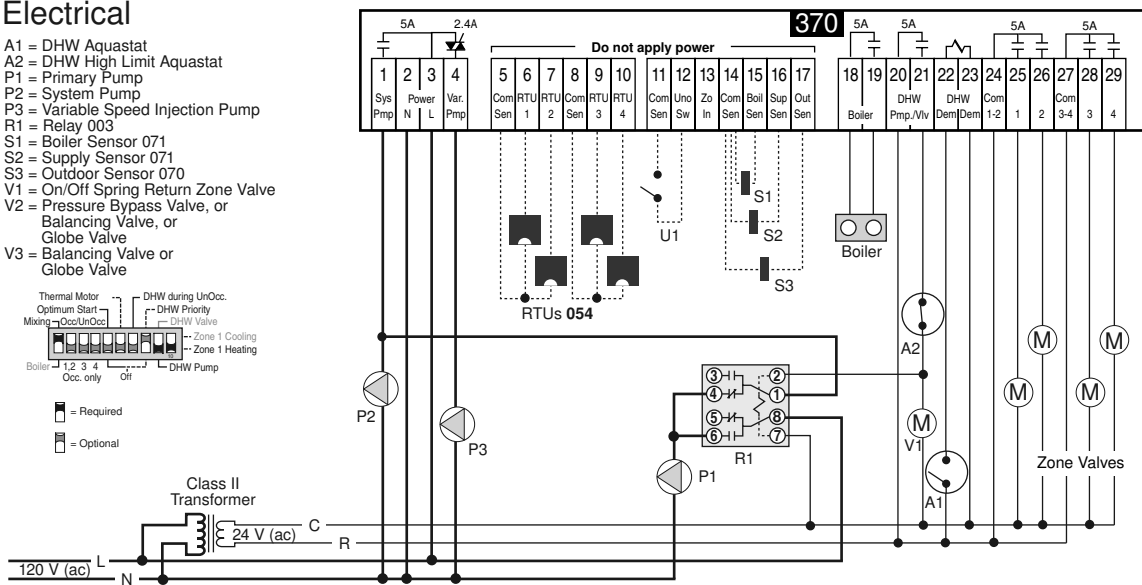

Note: This is only a concept drawing. The designer must determine whether this application will work in his system and must ensure compliance with code requirements. Necessary auxiliary equipment, isolation relays (for loads greater than the specified tekmar internal relay ratings), and other safety and limit devices must be added.

Access Levels

House Control 370 Four Zones, DHW, Boiler / Mixing

Literature	— D 370, A 370's, D 001, D 070, E 021.
Control	— Microprocessor PID control; This is not a safety (limit) control.
Packaged Weight	— 3.5 lb. (1600 g), Enclosure A, blue PVC plastic
Dimensions	— 6-5/8" H x 7-9/16" W x 2-13/16" D (170 x 193 x 72 mm)
Approvals	— CSA NRTL /C, meets ICES & FCC regulations for EMI/RFI.
Ambient conditions	— Indoor use only, 32 to 122°F (0 to 50°C), <90% RH non-condensing.
Power supply	— 120 V (ac) ±10% 50/60 Hz 1000 VA
Var. Pump	— 240 V (ac) 50/60 Hz 2.4 A 1/6 hp, fuse T2.5 A 250 V
Relays	— 120 V (ac) 5 A 1/3 hp, pilot duty 240 VA
Demands	— 24 to 120 V (ac) 2 VA
Sensors included	— NTC thermistor, 10 kΩ @ 77°F (25°C ±0.2°C) β=3892
	— Outdoor Sensor 070 and 2 of Universal Sensor 071
	— RTU 054 or 055. (Ordered Separately)
Optional devices	— tekmar type #: 031, 367, 368.
Timer	— 24 hour, 1 event / day, 3 minute backup
UnOcc. Duration	— 0 to 24 hours
Unoccupied	— 40 to 100°F (4 to 38°C)

Heating Curve	— 0.2 to 3.6
Max. System Supply	— 120 to 220°F (49 to 104°C)
Min. Boiler Supply	— Off, 100 to 165°F (Off, 38 to 74°C)

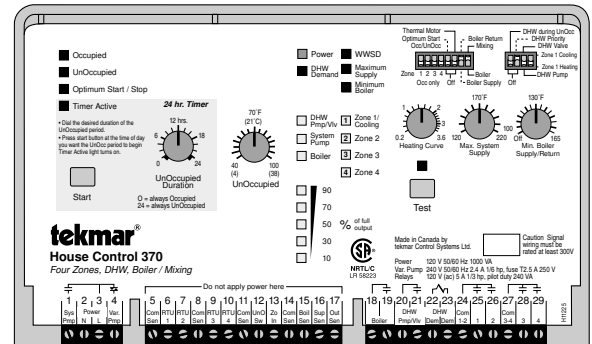

System Operation & Specifications

The House Control 370 controls the space temperature of four heating zones. The required supply water temperature to the zones is controlled by operating a boiler. The 370 also controls the supply of heat to a DHW tank.

Piping and Heat Source Details The system is plumbed with zone valves and a system pump. Either a high mass, low mass or a condensing boiler can be used with this application. Heat is supplied to the DHW tank through a DHW valve (V1).

Warm Weather Shut Down (WWSD) When the outdoor temperature rises above the highest RTU dial setting and the heating zones are satisfied, the 370 shuts down the heating system. The DHW system does, however, continue to operate.

Boiler Operation The 370 uses an outdoor reset strategy together with indoor temperature feedback from the RTUs to adjust the system supply water temperature. When heat is required in the zones, the 370 turns on the system pump (P1). In order to maximize boiler efficiency, the 370 operates the boiler at the lowest possible water temperature. The 370 automatically adjusts the boiler differential to prevent the boiler from short cycling.

Domestic Hot Water (DHW) When the DHW aquastat (A1) calls for heat, the 370 turns on the system pump (P1), opens the DHW valve (V1) and raises the boiler water temperature to at least 180°F (82°C). If *DHW Priority* is chosen, the 370 turns off the zone valves. Once the DHW demand is removed the 370 either performs a DHW Post Purge or a DHW Mixing Purge depending on whether or not the zones require heat.

Zoning Operation The 370 varies the on time of each zone valve based on a 15 minute cycle. The control staggers the operating times of the zones in order to achieve a steady load on the boiler and prevent boiler short cycling.

UnOccupied (Night Setback) Selected zones can be switched into an UnOccupied (Night Setback) mode through either the built-in 24 hr. Timer or by closing an external UnOccupied switch (U1). When the control is switched into UnOccupied mode, an UnOccupied dial is used to set the desired indoor temperature. An Optimum Start / Stop feature can be used to ensure the zones are returned to their Occupied temperatures as the UnOccupied period ends.

Other features Additional control features are listed in the table in the Heating Controls section of the Product Catalog I 000.



tekmar Control Systems Ltd., Canada
 tekmar Control Systems, Inc., U.S.A.
Head Office: 5100 Silver Star Road
Vernon, B.C. Canada V1B 3K4
Tel. (250) 545-7749 Fax. (250) 545-0650
Web Site: www.tekmarcontrols.com

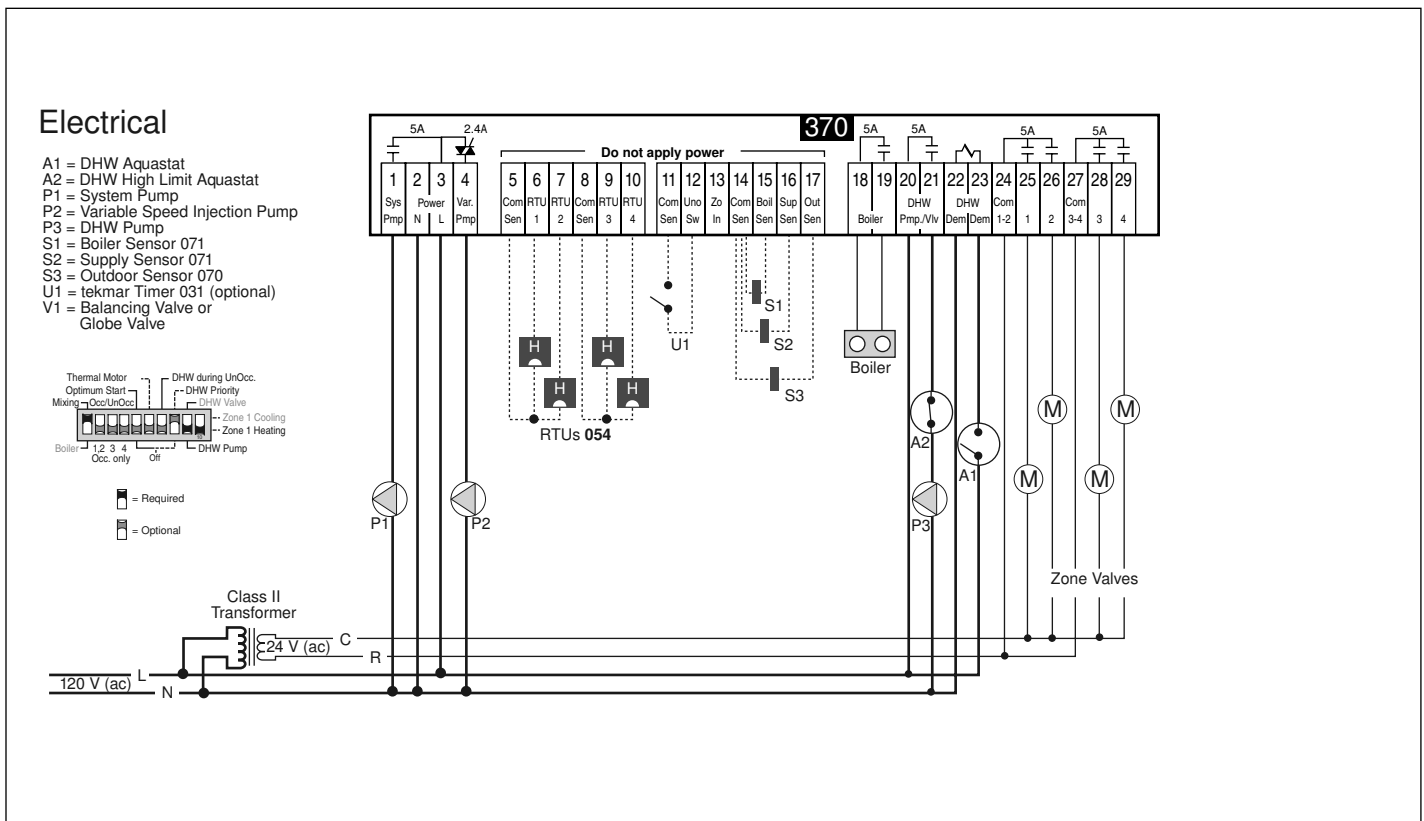
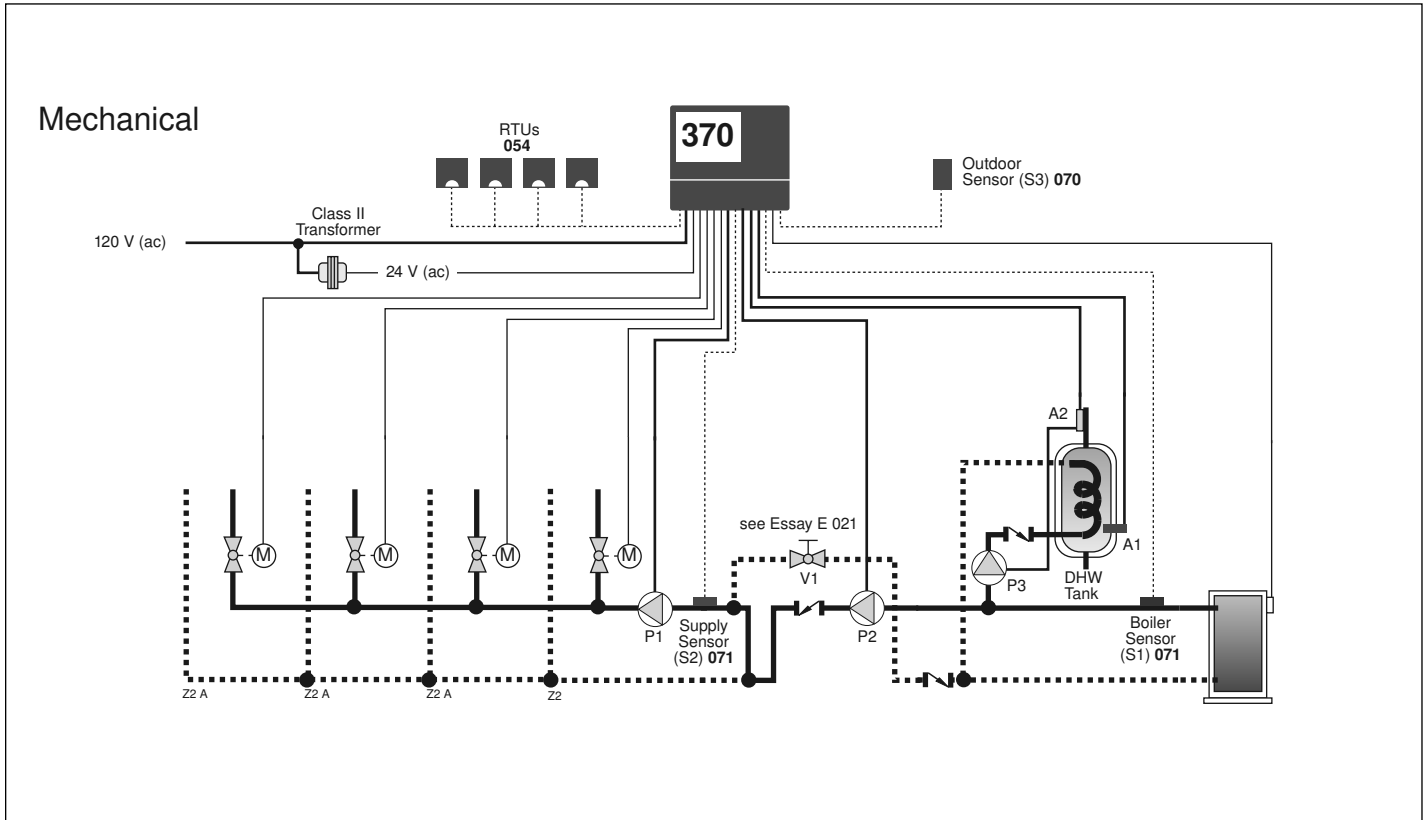
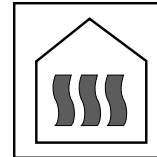

Note: This is only a concept drawing. The designer must determine whether this application will work in his system and must ensure compliance with code requirements. Necessary auxiliary equipment, isolation relays (for loads greater than the specified tekmar internal relay ratings), and other safety and limit devices must be added.

Access Levels

House Control 370 Four Zones, DHW, Boiler / Mixing

Literature Control	— D 370, A 370's, D 001, D 070, E 021.
Packaged Weight	— 3.5 lb. (1600 g), Enclosure A, blue PVC plastic
Dimensions	— 6-5/8" H x 7-9/16" W x 2-13/16" D (170 x 193 x 72 mm)
Approvals	— CSA NRTL /C, meets ICES & FCC regulations for EMI/RFI.
Ambient conditions	— Indoor use only, 32 to 122°F (0 to 50°C), <90% RH non-condensing.
Power supply	— 120 V (ac) ±10% 50/60 Hz 1000 VA
Var. Pump Relays	— 240 V (ac) 50/60 Hz 2.4 A 1/6 hp, fuse T2.5 A 250 V
Demands	— 120 V (ac) 5 A 1/3 hp, pilot duty 240 VA
Sensors included	— 24 to 120 V (ac) 2 VA
	— NTC thermistor, 10 kΩ @ 77°F (25°C ±0.2°C) β=3892
	— Outdoor Sensor 070 and 2 of Universal Sensor 071
required:	— RTU 054 or 055. (Ordered Separately)
Optional devices	— tekmar type #: 031, 367, 368.
Timer	— 24 hour, 1 event / day, 3 minute backup
UnOcc. Duration	— 0 to 24 hours
Unoccupied	— 40 to 100°F (4 to 38°C)

Heating Curve	— 0.2 to 3.6
Max. System Supply	— 120 to 220°F (49 to 104°C)
Min. Boiler Supply	— Off, 100 to 165°F (Off, 38 to 74°C)

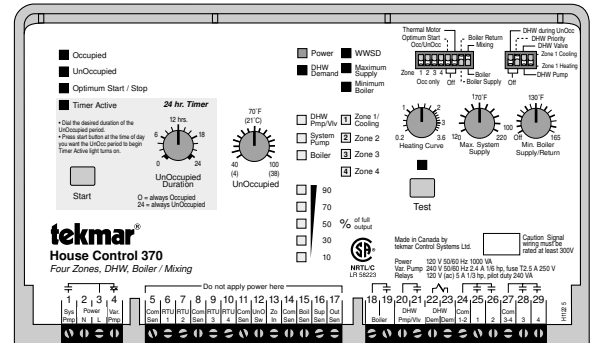

System Operation & Specifications

The House Control 370 controls the space temperature of four heating zones. The required supply water temperature to the zones is controlled by operating a boiler. The 370 also controls the supply of heat to a DHW tank.

Piping and Heat Source Details The system is plumbed with zone valves and a system pump. Either a high mass, low mass or a condensing boiler can be used with this application. Heat is supplied to the DHW tank through a DHW valve (V1).

Warm Weather Shut Down (WWSD) When the outdoor temperature rises above the highest RTU dial setting and the heating zones are satisfied, the 370 shuts down the heating system. The DHW system does, however, continue to operate.

Boiler Operation The 370 uses an outdoor reset strategy together with indoor temperature feedback from the RTUs to adjust the system supply water temperature. When heat is required in the zones, the 370 turns on the system pump (P1). In order to maximize boiler efficiency, the 370 operates the boiler at the lowest possible water temperature. The 370 automatically adjusts the boiler differential to prevent the boiler from short cycling.

Domestic Hot Water (DHW) When the DHW aquastat (A1) calls for heat, the 370 turns on the system pump (P1), opens the DHW valve (V1) and raises the boiler water temperature to at least 180°F (82°C). If *DHW Priority* is chosen, the 370 turns off the zone valves. Once the DHW demand is removed the 370 either performs a DHW Post Purge or a DHW Mixing Purge depending on whether or not the zones require heat.

Zoning Operation The 370 varies the on time of each zone valve based on a 15 minute cycle. The control staggers the operating times of the zones in order to achieve a steady load on the boiler and prevent boiler short cycling.

UnOccupied (Night Setback) Selected zones can be switched into an UnOccupied (Night Setback) mode through either the built-in 24 hr. Timer or by closing an external UnOccupied switch (U1). When the control is switched into UnOccupied mode, an UnOccupied dial is used to set the desired indoor temperature. An Optimum Start / Stop feature can be used to ensure the zones are returned to their Occupied temperatures as the UnOccupied period ends.

Other features Additional control features are listed in the table in the Heating Controls section of the Product Catalog I 000.



tekmar Control Systems Ltd., Canada
 tekmar Control Systems, Inc., U.S.A.
Head Office: 5100 Silver Star Road
Vernon, B.C. Canada V1B 3K4
Tel. (250) 545-7749 Fax. (250) 545-0650
Web Site: www.tekmarcontrols.com

tekmar® - Application

House Control 370

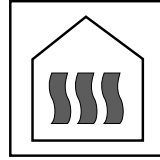

A 370-5

07/95

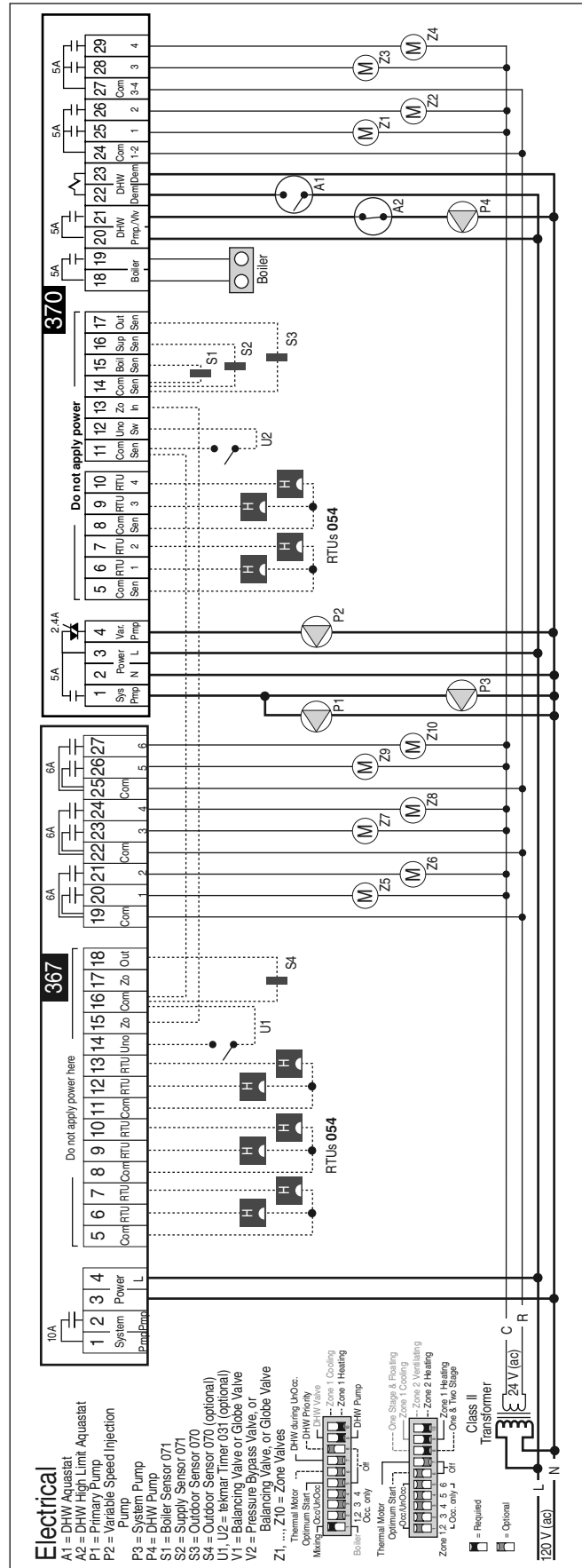
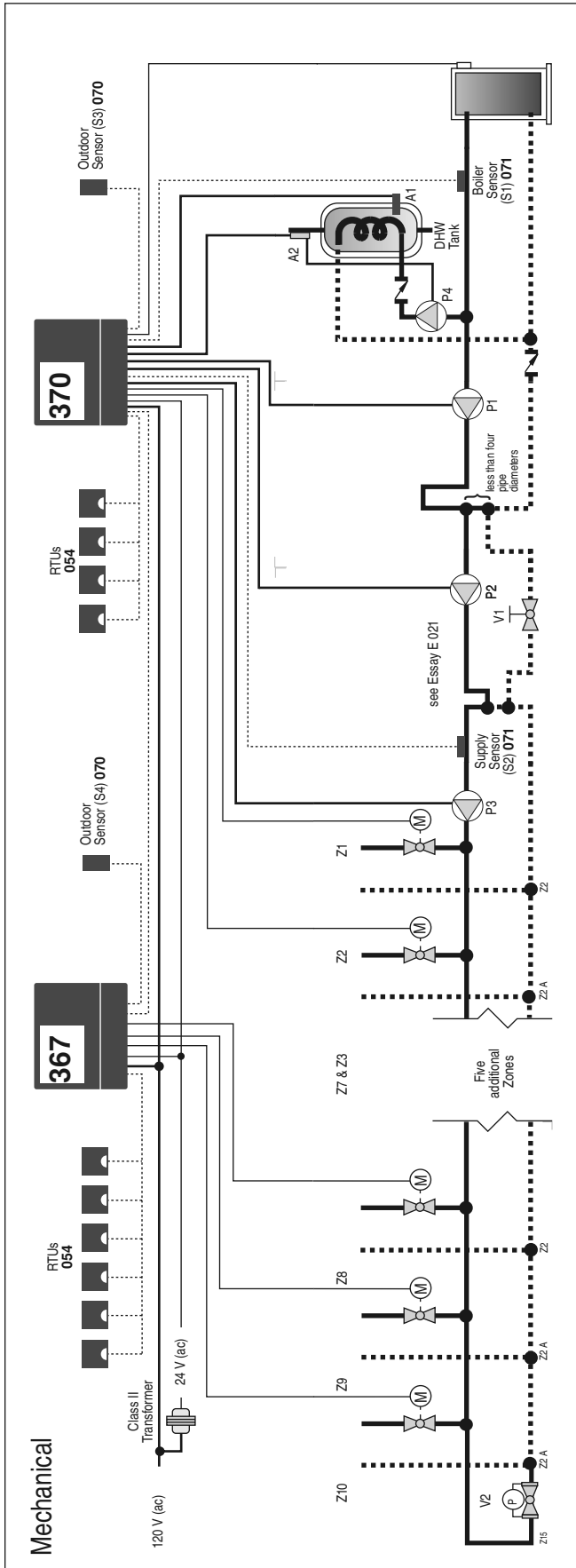

tekmar® - Application

House Control 370

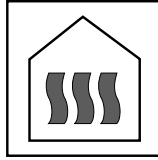

A 370-7

12/96

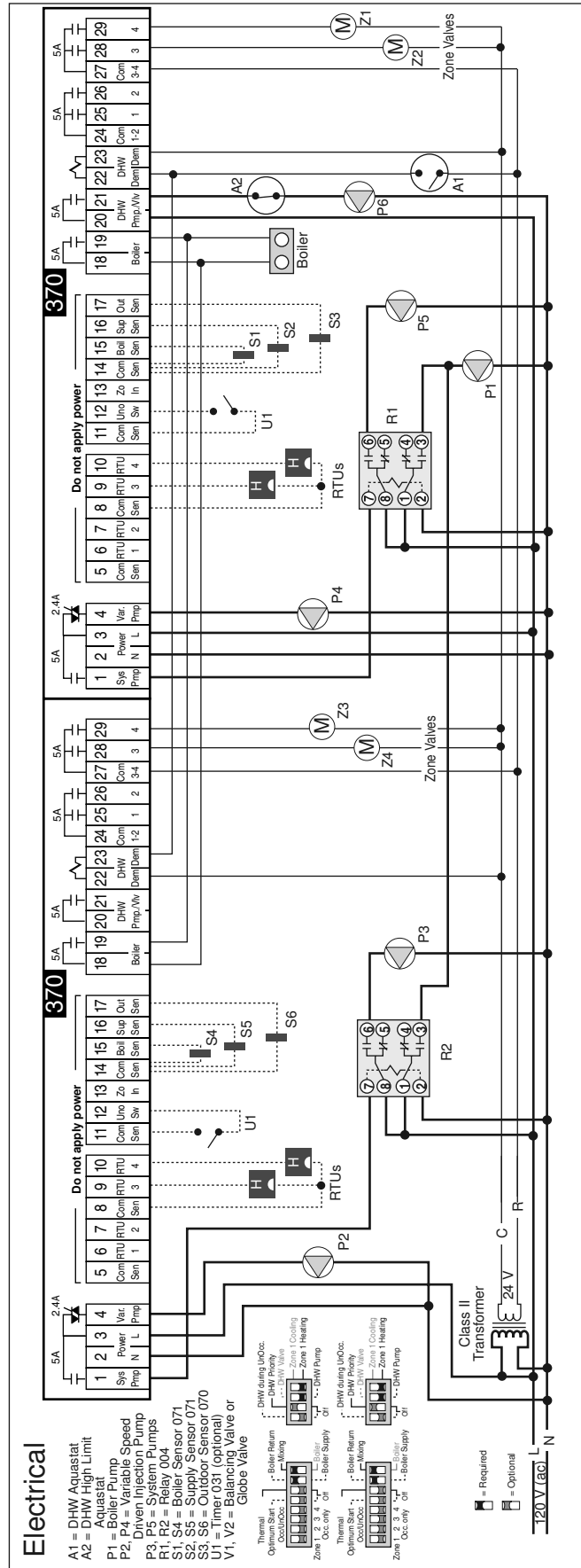
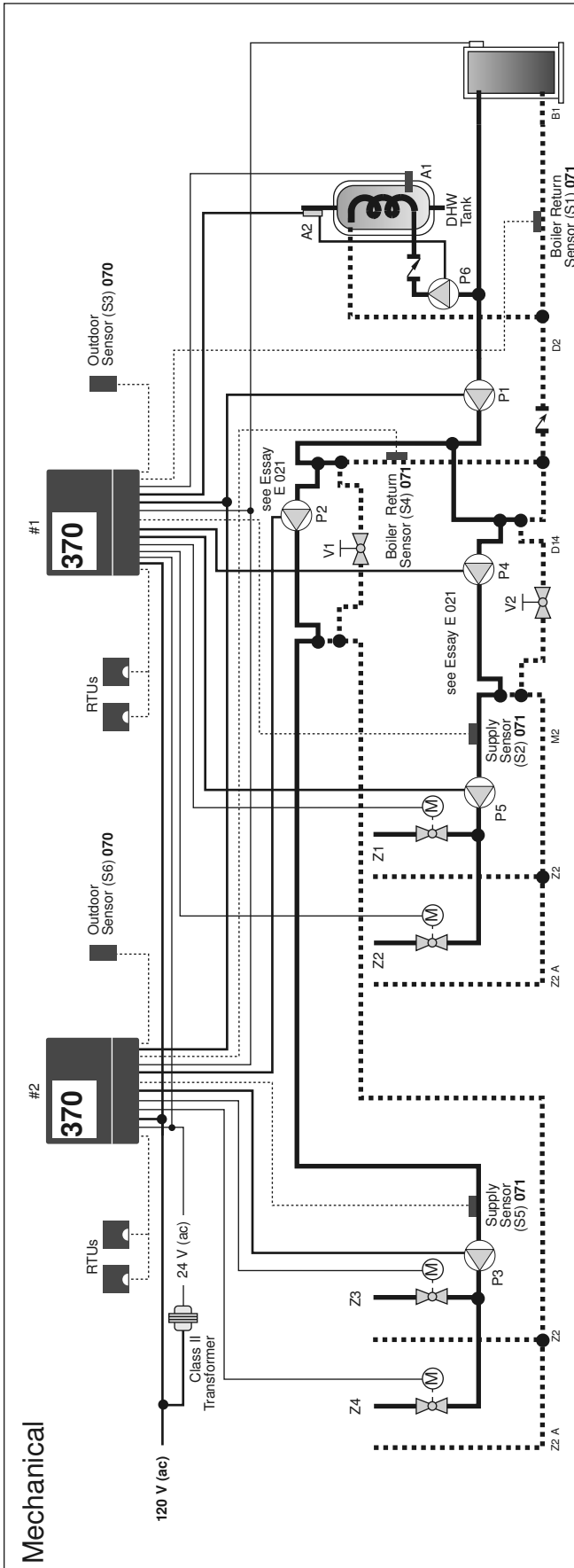

Note: This is only a concept drawing. The designer must determine whether this application will work in his system and must ensure compliance with code requirements. Necessary auxiliary equipment, isolation relays (for loads greater than the specified tekmar internal relay ratings), and other safety and limit devices must be added.

Access Levels

House Control 370 Four Zones , DHW, Boiler / Mixing

- Literature — D 370, A 370's, D 001, D 070, E 021.
- Control — Microprocessor PID control; **This is not a safety (limit) control.**
- Packaged Weight — 3.5 lb. (1600 g), Enclosure A, blue PVC plastic
- Dimensions — 6-5/8" H x 7-9/16" W x 2-13/16" D (170 x 193 x 72 mm)
- Approvals — CSA NRTL /C, meets ICES & FCC regulations for EMI/RFI.
- Ambient conditions — Indoor use only, 32 to 122°F (0 to 50°C), <90% RH non-condensing.
- Power supply — 120 V (ac) ±10% 50/60 Hz 1000 VA
- Var. Pump — 240 V (ac) 50/60 Hz 2.4 A 1/6 hp, fuse T2.5 A 250 V
- Relays — 120 V (ac) 5 A 1/3 hp, pilot duty 240 VA
- Demands — 24 to 120 V (ac) 2 VA
- Sensors included — NTC thermistor, 10 kΩ @ 77°F (25°C ±0.2°C) β=3892
- Optional devices required: — Outdoor Sensor 070 and 2 of Universal Sensor 071
- RTU 054 or 055. (Ordered Separately)
- tekmar type #: 031, 367, 368.
- Timer — 24 hour, 1 event / day, 3 minute backup
- UnOcc. Duration — 0 to 24 hours
- Unoccupied — 40 to 100°F (4 to 38°C)

- Heating Curve — 0.2 to 3.6
- Max. System Supply — 120 to 220°F (49 to 104°C)
- Min. Boiler Supply — Off, 100 to 165°F (Off, 38 to 74°C)

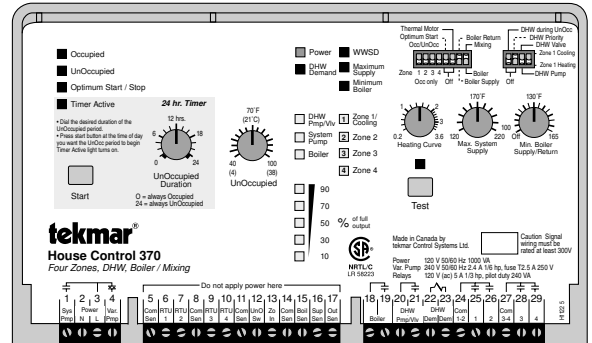

Two House Control 370's combine to provide two mixed supply temperatures and domestic hot water (DHW).

Piping and Heat Source Details The system is piped in a primary-secondary piping arrangement. The Variable Speed Driven Injection pumps (P2 and P4) inject heat from the boiler loop to the system loops. Balancing valves or globe valves (V1 and V2) may be required for optimum control operation as described in Essay E 021. The zone valves are plumbed in a direct return piping arrangement. Either a high mass boiler or a low mass boiler can be used with this application. Heat is supplied to the DHW tank through the DHW pump (P6).

Warm Weather Shut Down (WWSD) When the outdoor temperature rises above the highest RTU dial setting and the heating zones are satisfied, each 370 shuts down its portion of the heating system. The DHW system continues to operate.

Mixing Operation The 370's use an Outdoor Reset Strategy together with Indoor Temperature Feedback from the RTU's to adjust the system supply water temperatures. When heat is required in any of the zones, the 370 turns on the primary pump (P1) and the system pump (P3 or P5). The Variable Speed Driven Injection Pump (P2 or P4) is then controlled to supply the required system supply water temperature while protecting the boiler from excessively low return water temperatures and protecting the system from excessively high supply water temperatures.

Domestic Hot Water (DHW) When the DHW aquastat (A1) calls for heat, the 370 (#1) enables the DHW pump (P6) and both controls close their *Boiler* contacts in order to provide heat to the DHW tank. If *DHW Priority* is chosen, the 370's turn off the variable speed injection pumps (P2 and P4). Once the DHW demand is removed, the controls either perform a DHW Post Purge or a DHW Mixing Purge depending on whether or not any of the zones require heat.

Zoning Operation The 370's vary the on time of each zone valve based on a 15 minute cycle. The controls coordinate the operating times of the zones in order to achieve a steady load on the boiler and prevent boiler short cycling.

UnOccupied (Night Setback) Selected zones can be switched into an UnOccupied (Night Setback) mode through either the built-in 24 Hr. Timers or by closing an external switch (U1) such as a Timer 031. When a 370 is switched into UnOccupied mode, its *UnOccupied* dial is used to set the desired indoor temperature. An Optimum Start / Stop feature can be used to ensure the zones are returned to their Occupied temperatures as the UnOccupied period ends.

Additional Functions Additional functions are listed in the table in the Heating Controls section of the Product Catalog I 000 and the Application Catalog A 000.

	tekmar Control Systems Ltd., Canada tekmar Control Systems, Inc., U.S.A. Head Office: 5100 Silver Star Road Vernon, B.C. Canada V1B 3K4 Tel. (250) 545-7749 Fax. (250) 545-0650 Web Site: www.tekmarcontrols.com
---	---

Access Levels

House Control 370 Four Zones, DHW, Boiler / Mixing

- Literature — D 370, A 370's, D 001, D 070, E 021.
- Control — Microprocessor PID control; **This is not a safety (limit) control.**
- Packaged Weight — 3.5 lb. (1600 g), Enclosure A, blue PVC plastic
- Dimensions — 6-5/8" H x 7-9/16" W x 2-13/16" D (170 x 193 x 72 mm)
- Approvals — CSA NRTL /C, meets ICES & FCC regulations for EMI/RFI.
- Ambient conditions — Indoor use only, 32 to 122°F (0 to 50°C), <90% RH non-condensing.
- Power supply — 120 V (ac) ±10% 50/60 Hz 1000 VA
- Var. Pump — 240 V (ac) 50/60 Hz 2.4 A 1/6 hp, fuse T2.5 A 250 V
- Relays — 120 V (ac) 5 A 1/3 hp, pilot duty 240 VA
- Demands — 24 to 120 V (ac) 2 VA
- Sensors included — NTC thermistor, 10 kΩ @ 77°F (25°C ±0.2°C) β=3892
- Outdoor Sensor 070 and 2 of Universal Sensor 071
- required: — RTU 054 or 055. (Ordered Separately)
- Optional devices — tekmar type #: 031, 367, 368.
- Timer — 24 hour, 1 event / day, 3 minute backup
- UnOcc. Duration — 0 to 24 hours
- Unoccupied — 40 to 100°F (4 to 38°C)

- Heating Curve — 0.2 to 3.6
- Max. System Supply — 120 to 220°F (49 to 104°C)
- Min. Boiler Supply — Off, 100 to 165°F (Off, 38 to 74°C)

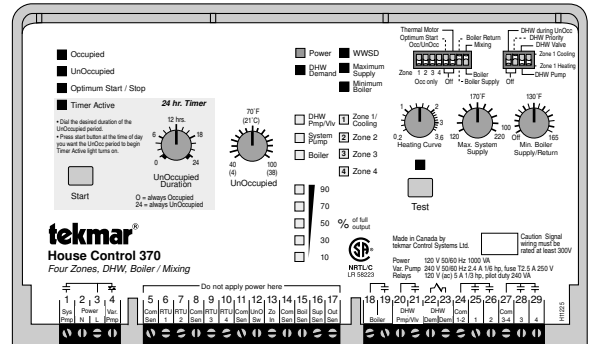

System Operation & Specifications

The Boiler Control 262 and the House Control 370 combine to provide full outdoor reset to four zones of heating using Room Temperature Units (RTU's) as well as Domestic Hot Water (DHW) operation and staging and rotation of two boilers. The output of the variable speed injection pump is modulated to mix down the boiler supply water temperature to the mixed zones and protect the boiler from flue gas condensation. The boiler operates at the required temperature in order to satisfy all loads.

Heat Source Details The heat source can be either a high mass or low mass non-condensing boiler.

Piping Details Room Temperature Unit (RTU) controlled zone pumps are piped into the mixed loop. The variable speed injection pump is piped in primary / secondary in order to isolate the boiler loop flow rate from the mixed loop flow rate. The DHW tank is also piped into the boiler loop using primary / secondary. Heat is supplied to the DHW tank through a DHW pump. The boiler pump (P1) ensures flow past the variable speed injection pump and DHW pump take-offs.

Heating Zones The air temperatures in the mixed zones are controlled using RTU's. The House Control 370 uses PID (proportional, integral, derivative) air temperature control and synchronizes the operation of the zones to provide more even loading of the mixed system. The 370 uses its Boiler contact terminals to send a Boiler Demand to the 262 when the mixed zones require heat.

DHW Demand When the DHW aquastat (A1) calls for heat, The 262 turns on both the DHW pump (P3) and the boiler pump (P1) and raises the boiler water temperature to at least the DHW XCHG temperature setting. The House Control 370 can provide DHW Priority by turning off the variable speed injection pump (P2).

Boiler Demand When heat is required in the mixed zones, The House Control 370 provides a Boiler Demand to the 262. The 262 turns on the boiler pump (P1). The mix supply water temperature is based on the Heating Curve setting and indoor temperature feedback from the House Control 370. The variable speed injection pump is then controlled to supply the required mixed supply water temperature. Whenever the boiler is firing, the variable speed injection pump is also modulated to protect the boiler from excessively low water temperatures.

All control functions and specifications are listed in the Product Catalog I 000 and Data Brochure D 370 & D 262.



tekmar Control Systems Ltd., Canada
 tekmar Control Systems, Inc., U.S.A.
Head Office: 5100 Silver Star Road
Vernon, B.C. Canada V1B 3K4
Tel. (250) 545-7749 Fax. (250) 545-0650
Web Site: www.tekmarcontrols.com